

Instrument Manual

Ex Remote Terminal for Maxxis 5 PR 5900/60, ../70



Translation of the Original Instrument Manual

9499 050 59700

Edition 3.6.1

02/29/2024

Release 1.00.xx

Foreword

Must be followed!

Any information in this document is subject to change without notice and does not represent a commitment on the part of Minebea Intec unless legally prescribed. This product should only be operated/installed by trained and qualified personnel. In correspondence concerning this product, the type, name, and release number/serial number as well as all license numbers relating to the product have to be cited.

Note

This document is partially protected by copyright. It may not be changed or copied, and it may not be used without purchasing or written permission from the copyright owner (Minebea Intec). The use of this product constitutes acceptance by you of the abovementioned provisions.

Table of contents

1	Introduction.....	4
1.1	Read the manual.....	4
1.2	This is what operating instructions look like.....	4
1.3	This is what lists look like.....	4
1.4	This is what menu items and softkeys look like.....	4
1.5	This is what the safety instructions look like.....	4
1.6	Hotline.....	5
2	Safety instructions.....	6
2.1	General notes.....	6
2.2	Intended use.....	6
2.3	Non-intended use.....	6
2.4	Initial inspection.....	6
2.5	Before operational startup.....	7
2.5.1	Installation.....	7
2.5.2	Opening the device.....	7
2.5.3	RF interference suppression.....	8
2.5.4	Failure and excessive stress.....	8
2.5.5	Important note.....	8
2.5.6	Repairs and maintenance.....	8
3	Remote terminal.....	9
3.1	General notes.....	9
3.2	Overview of the device.....	9
3.2.1	Communication.....	9
3.2.2	Supply voltage.....	9
3.3	Housing.....	9
3.3.1	General notes.....	9
3.3.2	Dimensions.....	10
3.4	Overview of connections.....	13
3.5	Device versions.....	14
4	Device installation.....	16
4.1	General notes.....	16
4.2	Control cabinet equipment.....	16
4.3	Table-top devices.....	17
4.3.1	Cable gland.....	17
4.3.2	Installation of a cable.....	19
4.3.3	Tightening torques.....	20
4.4	EMC-compliant installation.....	22
4.4.1	Connecting the screens to the screen clamping rail.....	22

4.4.2	Connecting the equipotential bonding conductor	22
4.5	Hardware construction	23
4.5.1	Main board	23
4.5.2	Maxxis 5 connection	24
4.5.3	RS-485 interface	25
4.5.4	TTY interface	27
4.5.5	Digital inputs	29
4.5.6	Digital outputs	31
4.5.7	PS/2 interface	32
4.5.8	Connecting power supply YPSC01-* (with Ex approval)	35
4.5.9	Connecting weighing electronics board "WE1" to Maxxis 5	36
4.5.10	Analog connections	37
4.5.11	Connecting a load cell with a 4-wire cable	38
4.5.12	Connecting a load cell with a 6-wire cable	39
5	Getting started	40
5.1	Switching on the device	40
5.2	Assigning a specific Maxxis 5 and remote terminal	41
5.2.1	Procedure for operation in legal metrology	42
5.2.2	Procedure for operation in non-legal metrology	42
5.3	Switching off the device	42
6	Repairs and maintenance	43
6.1	Repairs	43
6.2	Maintenance	43
6.3	Soldering work	43
6.4	Cleaning	43
7	Disposal	44
8	Error correction	45
8.1	Connection to the Maxxis 5 is interrupted	45
9	Technical data	46
9.1	Decoding the serial number	46
9.2	General data	46
9.2.1	Display	46
9.3	Possible marking for the Ex area	46
9.4	Effect of ambient conditions	47
9.4.1	Ambient conditions	47
9.4.2	Electromagnetic Compatibility (EMC)	47
9.4.3	RF interference suppression	47
9.5	Mechanics	47
9.5.1	Design	47
9.5.2	Dimensions	47

9.5.3	Weights.....	47
9.6	Documentation on the CD included	47
10	Appendix	48
10.1	Certificates/control drawing/safety instructions.....	48

1 Introduction

1.1 Read the manual

- Please read this manual carefully and completely before using the product.
- This manual is part of the product. Keep it in a safe and easily accessible location.

1.2 This is what operating instructions look like

1. - n. are placed before steps that must be done in sequence.
 - ▶ is placed before a step.
 - ▷ describes the result of a step.

1.3 This is what lists look like

- indicates an item in a list.

1.4 This is what menu items and softkeys look like

[] frame menu items and softkeys.

Example:

[Start]- [Applications]- [Excel]

1.5 This is what the safety instructions look like

Signal words indicate the severity of the danger involved when measures for preventing hazards are not followed.

DANGER

Warning of personal injury

DANGER indicates death or severe, irreversible personal injury which will occur if the corresponding safety measures are not observed.

- ▶ Take the corresponding safety precautions.

WARNING

Warning of hazardous area and/or personal injury

WARNING indicates that death or severe, irreversible injury may occur if appropriate safety measures are not observed.

- ▶ Take the corresponding safety precautions.

CAUTION

Warning of personal injury.

CAUTION indicates that minor, reversible injury may occur if appropriate safety measures are not observed.

- ▶ Take the corresponding safety precautions.

NOTICE**Warning of damage to property and/or the environment.**

NOTICE indicates that damage to property and/or the environment may occur if appropriate safety measures are not observed.

- ▶ Take the corresponding safety precautions.
-

Note:

User tips, useful information, and notes.

1.6 Hotline

Phone: +49.40.67960.444

Fax: +49.40.67960.474

eMail: help@minebea-intec.com

2 Safety instructions

2.1 General notes

CAUTION

Warning of personal injury.

The product was in perfect condition with regard to safety features when it left the factory.

- ▶ To maintain this condition and to ensure safe operation, the user must follow the instructions and observe the warnings in this manual.

2.2 Intended use

The remote terminal is intended for unlimited operation of a Maxxis 5.

The remote terminal is prepared for running in verifiable applications.

The remote terminal is designed for operation in potentially explosive atmospheres of Zone 1 (PR 5900/60) and 21 (PR 5900/70 only).

Maxxis 5 is fitted with several intrinsically safe interfaces. For the operation of the Ex-remote terminal, the power supply YPSC01-X or YPSC01-Z is required.

Product operation, commissioning and maintenance must be performed by trained and qualified personnel who are aware of and able to deal with the related hazards and take suitable measures for self-protection.

The device reflects the state of the art.

No warranty is given that the product is free of faults, especially not in conjunction with third-party software and hardware components required for operation.

The manufacturer does not accept any liability for damage caused by third-party system components or due to incorrect use of the product. The use of this product signifies recognition of the stipulations listed above.

2.3 Non-intended use

The remote terminal PR 5900/60, ../70 may not be used in the safe area (normal industrial environment)

The remote terminal PR 5900/61, ../71 absolutely must be used in this area.

2.4 Initial inspection

Check the contents of the consignment for completeness. Check the contents visually to determine whether any damage has occurred during transport. If there are grounds for rejection of the goods, a claim must be filed with the carrier immediately. The Minebea Intec sales or service organization must also be notified.

2.5 Before operational startup

NOTICE

Perform visual inspection.

- ▶ Before operational startup as well as after storage or transport, inspect the device visually for signs of mechanical damage.
- ▶ Before operational startup, acceptance of the installation by an authorized expert is compulsory.

2.5.1 Installation

The device has to be installed in an EMC-compliant manner.

Setup

Version	Protection class	Installation
Control cabinet housing	IP65, rear IP20	Control panel cut-out
Table-top housing	IP65	

To ensure proper cooling of the device, make sure air circulation around the device is not blocked. Avoid exposing the instrument to excessive heat, e.g. from direct sunlight. The ambient conditions in Chapter [9.4.1](#) must be taken into account at all times.

With outdoor mounting, make sure that adequate weather protection is provided (for temperatures, see Chapter [9.4.1](#)).

2.5.2 Opening the device

2.5.2.1 Control cabinet housing

The housing must not be opened.

Cables are connected to the electronics at the back of the housing.

2.5.2.2 Table-top housing

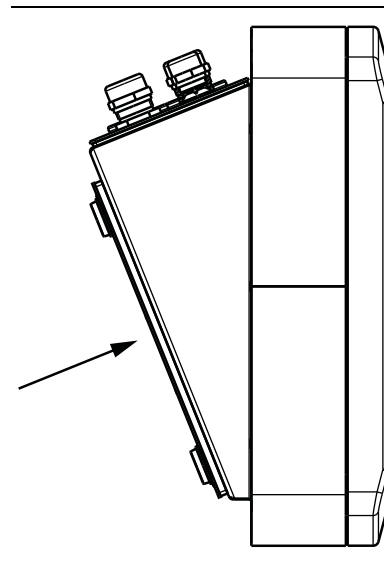

A base plate is located on the underside of the housing (see arrow). This plate must be removed to connect the screw-in cables to the electronics.

2.5.3 RF interference suppression

The device is intended for use in an industrial environment. Operation of this device in a residential environment is likely to cause radio frequency interference, see Chapter [9.4.3](#). In this case, the operator may be required to take appropriate measures.

2.5.4 Failure and excessive stress

If there is any reason to assume that safe operation of the device is no longer ensured, shut it down and make sure it cannot be used.

Safe operation is no longer ensured if any of the following is true:

- The device is physically damaged.
- The device does not function.
- The device has been subjected to stresses beyond the tolerance limits (e.g., during storage or transport).

2.5.5 Important note

Make sure that the construction of the device is not altered to the detriment of safety. In particular, leakage paths, air gaps (of live parts) and insulating layers must not be reduced.

Minebea Intec cannot be held responsible for personal injury or property damage caused by a device repaired incorrectly by an operator or installer.

2.5.6 Repairs and maintenance

2.5.6.1 General information

Repairs are subject to inspection and must be carried out at Minebea Intec.

In case of defect or malfunction, please contact your local Minebea Intec dealer or service center for repair.

When returning the device for repair, please include a precise and complete description of the problem.

Maintenance work may only be carried out by a trained technician with expert knowledge of the hazards involved and the required precautions.

2.5.6.2 Electrostatically sensitive parts

This device contains electro-statically sensitive components. Therefore, potential equalization must be provided when working on the device (antistatic protection).

2.5.6.3 Replacing fuses

No fuses are present in the device.

3 Remote terminal

3.1 General notes

The device is equipped with a TFT color graphics display and a function/alphanumeric keypad.

3.2 Overview of the device

- Weight display with status and weight unit on a TFT color display
- Connections for a maximum of 6 analog load cells
- 4 digital inputs (active)
- 4 digital outputs (passive)
- RS-485 interface for xBPI platforms with Ex approval
- Interface for PS/2 key with Ex approval
- TTY interface for barcode scanner with Ex approval

3.2.1 Communication

The CX1 module must be integrated into the Maxxis 5.

Data is transferred between the operator terminal and Maxxis 5 via a dedicated Ethernet connection (point-to-point permanent connection). The protocol is proprietary (not public).

3.2.2 Supply voltage

Power supply YPSC01-X or YPSC01-Z is required for the electrical supply.

3.3 Housing

3.3.1 General notes

The following housing options are available:

- Stainless steel housing for the switchbox installation (for PR 5900/60), see Chapter [3.3.2.1](#)
- Stainless steel housing for table-top mounting (for PR 5900/70), see Chapter [3.3.2.2](#)

3.3.2 Dimensions

3.3.2.1 Control cabinet housing

The keypad and the display form one unit with the front. A rectangular cut-out is required for the installation. Cable connections are made at the back of the housing.

Front view

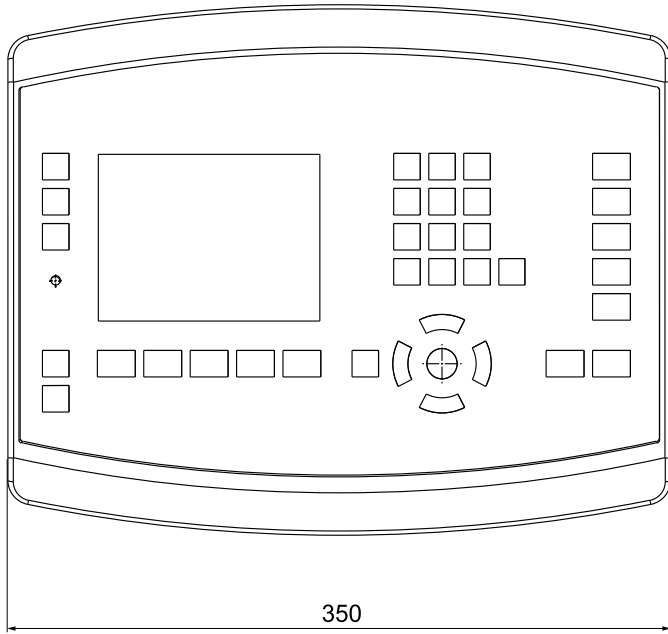

All dimensions in mm

Side view

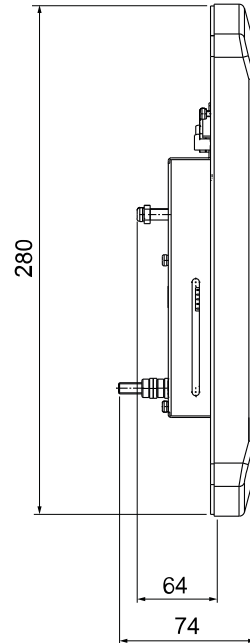

All dimensions in mm

Back view

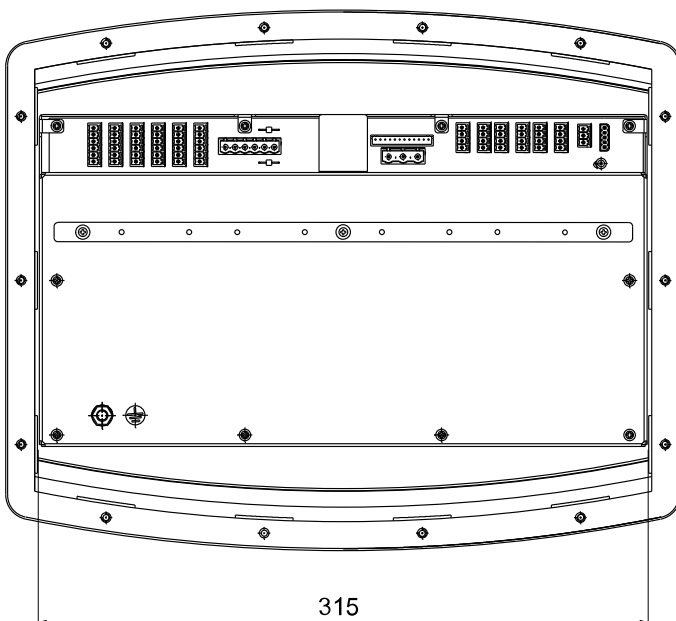

All dimensions in mm

3.3.2.1.1 Drilling template and control panel cut-out

The drilling template (shown in a reduced size) with control panel cut-out is included as an original in the scope of supply.

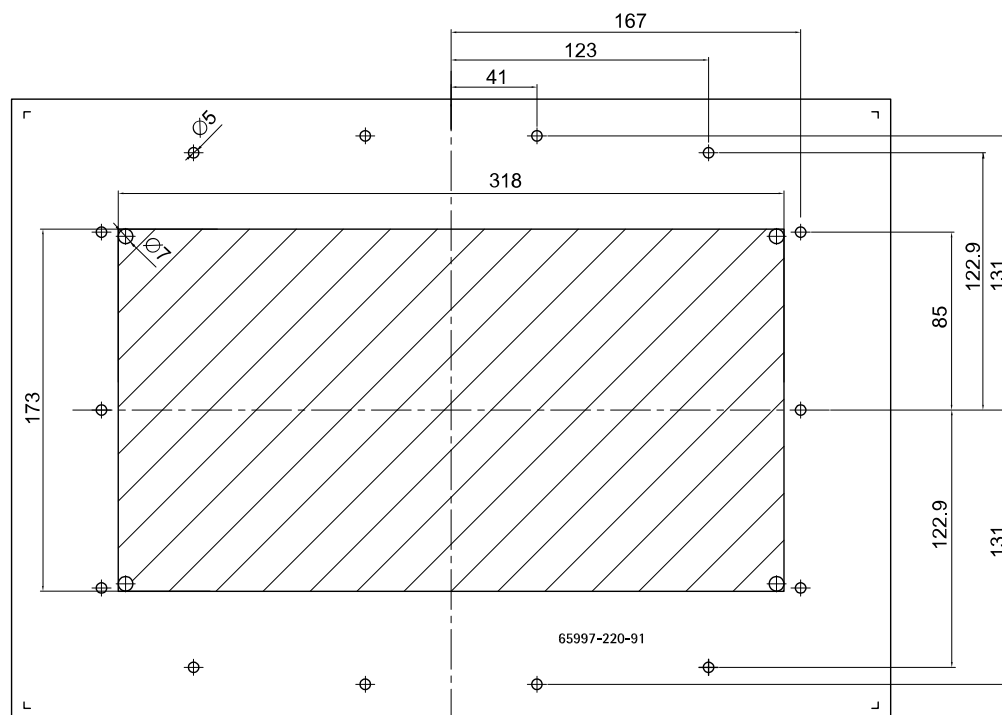

All dimensions in mm

3.3.2.2 Table-top housing

The keypad and the display form one unit with the front. The cables are fed through entry glands on the bottom of the housing and connected to the electronics.

Front view

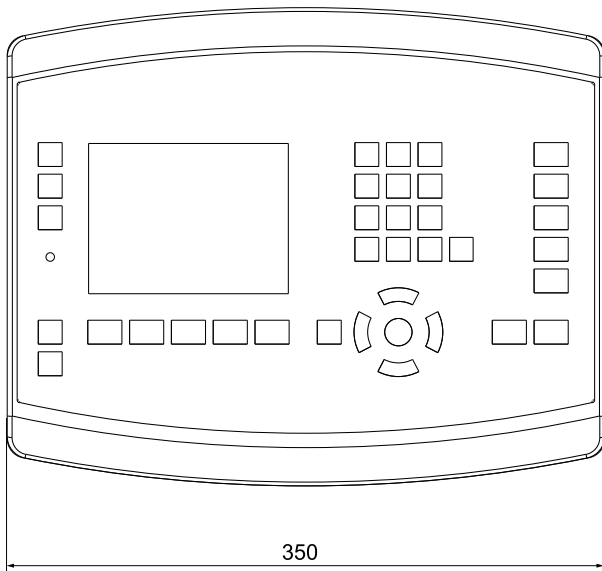

Side view, turned

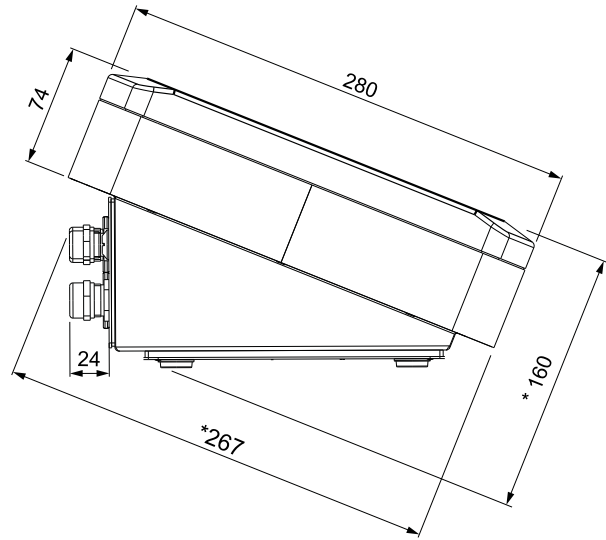

* approximations

All dimensions in mm

Back view

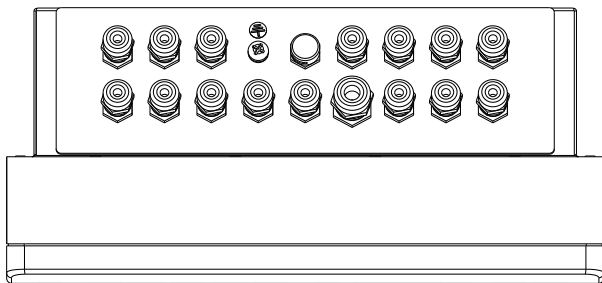

3.4 Overview of connections

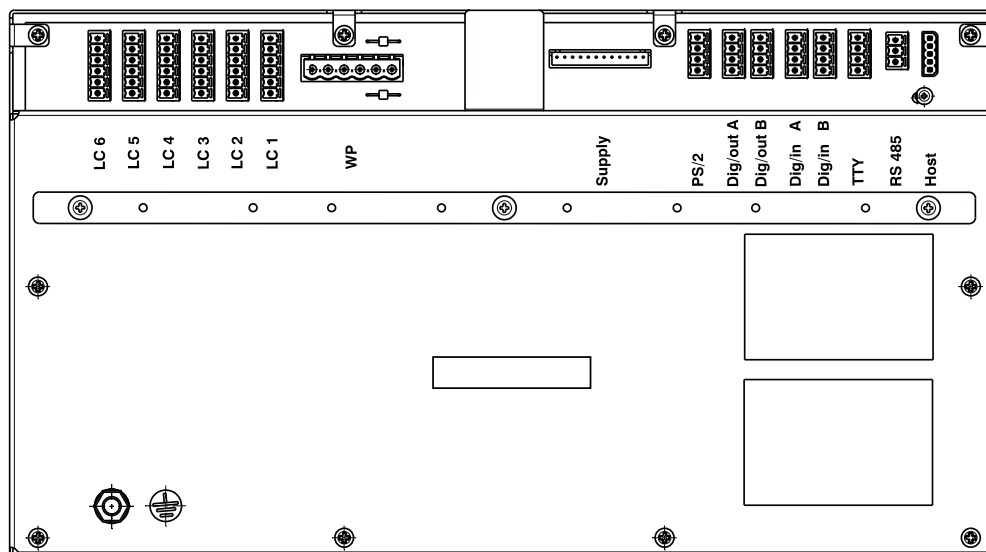

Connection	Description
LC 1 to LC 6 Load cell connections	Connections for a maximum of 6 analog load cells with Ex approval
WP Weighing point connection	Connection to the weighing electronics WE1 (Ex) in the Maxxis 5
Supply Power supply connection	For power supply YPSC01-X or YPSC01-Z
PS/2 Keyboard connection	For an external keyboard with Ex approval
Dig/out A Dig/out B	4 x digital output (passive)
Dig/in A Dig/in B	4 x digital input (active)
TTY Interface	Connection for barcode scanner with Ex approval without an external power supply
RS-485 RS-485 interface	Connection for xBPI platforms with Ex approval
Host Dedicated Ethernet connection	Connection for the Maxxis 5

3.5 Device versions

Housing:

Designation	Code no.	Description	Chap.
Control cabinet housing	PR 5900/60	Default	3.3.2.1
Table-top housing	PR 5900/70	Default	3.3.2.2

Housing backs:

Designation	Code no.	Description
Back plate with cable glands for table-top housing	L12	Default

Power supply:

Designation	Code no.	Description	Chap.
Power supply	YPSC01-X YPSC01-Z	Freely configurable power communication system (power supply)	4.5.8

Interface cards:

Designation	Code no.	Description	Chap.
Module with plug for Ex zone	CX1	Connection for the Maxxis 5 The module must be integrated into the Maxxis 5 at the factory.	Option CX1 additional information

Cable connections:

Designation	PR 5900/60	Maxxis 5	Box-A9-PSCAN-F2_N
Power supply YPSC01* cable	N34 (x m) N35 (3 m)		
Host cable		CAT5 S/FTP data cable, with 4 wires, braided, e.g., EtherLine®-P CAT. 5 2x2x24AWG	
Cable connection unit for intrinsically safe barcode scanner PSCAN-D-1* (Pepperl+Fuchs GmbH)			DatL-A4-0.75-0 4 × 0.75 mm ² ; ø7 mm; blue (Pepperl+Fuchs GmbH)

Cable with cable gland:

Designation	PR 5900/70	Maxxis 5	Box-A9-PSCAN-F2_N
Power supply YPSC01* cable	N32 (x m) N33 (3 m)		
Host cable		CAT5 S/FTP data cable, with 4 wires, braided, e.g., EtherLine®-P CAT. 5 2x2x24AWG	
Cable connection unit for intrinsically safe barcode scanner PSCAN-D-1* (Pepperl+Fuchs GmbH)			DatL-A4-0.75-0 4 × 0.75 mm ² ; ø7 mm; blue (Pepperl+Fuchs GmbH)

4 Device installation

4.1 General notes

Before starting work, please read Chapter 2 and follow all instructions.

⚠ WARNING

Warning of hazardous area and/or personal injury

- ▶ All cable connections must be protected from damage.

Note:

- Measurement cables should be kept away from power equipment.
- Signal cables and measurement cables should be installed separately from electric power lines.
- It is recommended that measurement cables are laid in separate cable conduits.
- Power cables should be crossed at right angles.

Further procedures:

- Check the consignment: make sure that all components are present.
- Safety check: inspect all components for damage.
- Make sure that the on-site installation is correct and complete including cables, e.g. power cable fuse protection, load cells, junction box, data cables, console/cabinet, etc.
- Follow all device installation instructions related to application, safety, ventilation, sealing and environmental influences.
- Connect the cable from the junction box or platform/load cell.
- If applicable: connect other data cables, network cables, etc.
- Connect to supply voltage.
- Check the installation.

4.2 Control cabinet equipment

Have all required parts, technical documents, and tools at hand for control cabinet installation.

NOTICE

Ingress of dirt through the air vent in the housing.

There is a risk of damage being caused to the device.

- ▶ Ensure that dirt does not enter the device when performing mechanical work on it and/or in its vicinity.

Other procedure:

- Make the drillings and control panel cut-out for the device in the control cabinet door, for example; see Chapter [3.3.2.1.1](#).
- Install the device.
- Secure the cable at the place of installation, e.g. using cable ties.
- Remove the insulation from the cable ends and keep the strands short.
- Connect the screens to the screen clamping rail using screen terminals; see Chapter [4.4.1](#).
- Establish grounding/equipotential bonding between devices/system components (this is essential for Ex applications).

4.3 Table-top devices**4.3.1 Cable gland**

The cables have to be fed into the device via glands to ensure leak-tightness. The following cable diameters are suitable: 9...13 mm for gland M20×1.5 and 5...9 mm for cable gland M16×1.5.

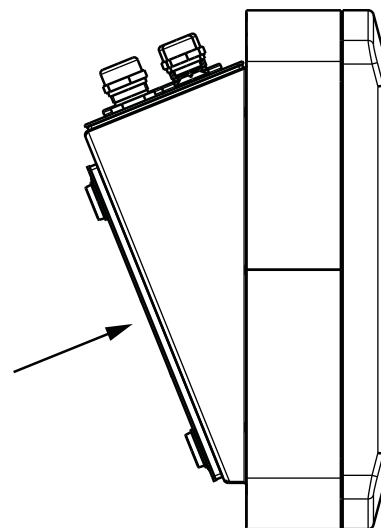

A base plate is located on the underside of the housing (see arrow). This plate must be removed to connect the screw-in cables to the electronics.

The cable wires are connected to the terminals inside the device.

The connections are made via plug-in terminals.

The conductors taken to the terminals shall be as short as possible. The wires of each cable must be tied together with a cable strap shortly before the terminal.

NOTICE

For protection against dust and moisture during transport and installation, the cable glands are fitted with a polyethylene cover.

For full IP protection, operation with the dust protection cover fitted is not permitted.

- ▶ Remove the dust protection cover.
- ▶ If a cable gland is not used, it must be sealed with a supplied locking pin.

NOTICE**Property damage is possible.**

- Regularly check the fitted cable gland for tightness and re-tighten it, if necessary.

Cabling

In principle, the cables can be taken through all cable glands corresponding to the cable diameters. The following figure shows a proposed topology.

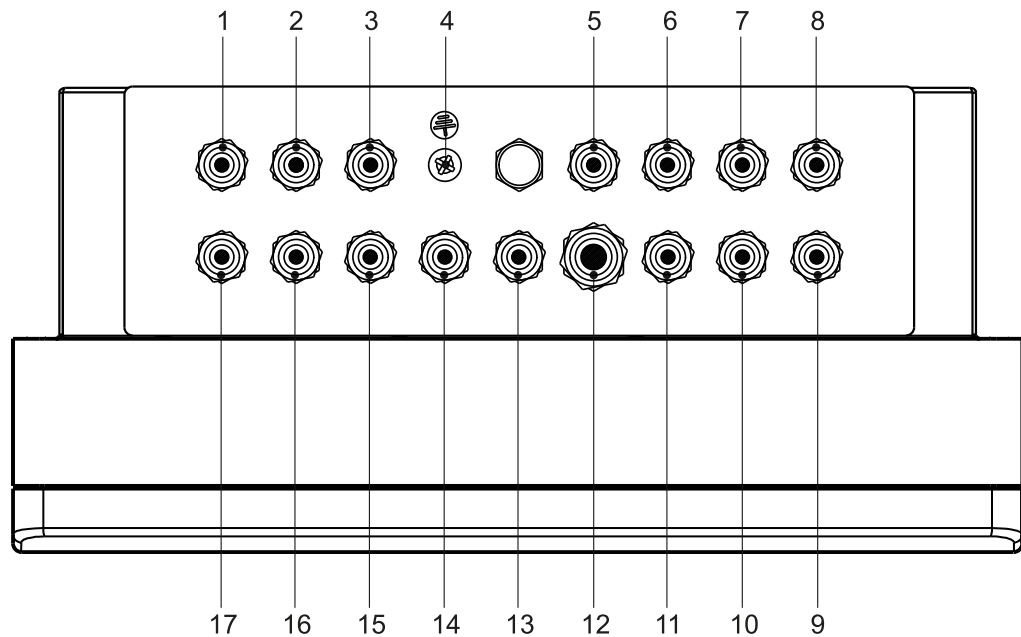

No.	Description
1	Maxxis 5 "Host" port
2	"TTY" interface for barcode scanner with Ex approval
3	Digital inputs "Dig/in A"
4	Port for the potential equalization
5	"Supply" port for the power supply
6	"LC 1" load cell
7	"LC 3" load cell
8	"LC 5" load cell
9	"LC 6" load cell
10	"LC 4" load cell
11	"LC 2" load cell
12	"WP" port for the weighing electronics in the Maxxis 5
13	"PS/2" port for the external PC keyboard with Ex approval
14	Digital outputs "Dig/out A"
15	Digital outputs "Dig/out B"

No.	Description
16	Digital inputs "Dig/in B"
17	"RS 485" interface for xBPI scale with Ex approval

4.3.2 Installation of a cable

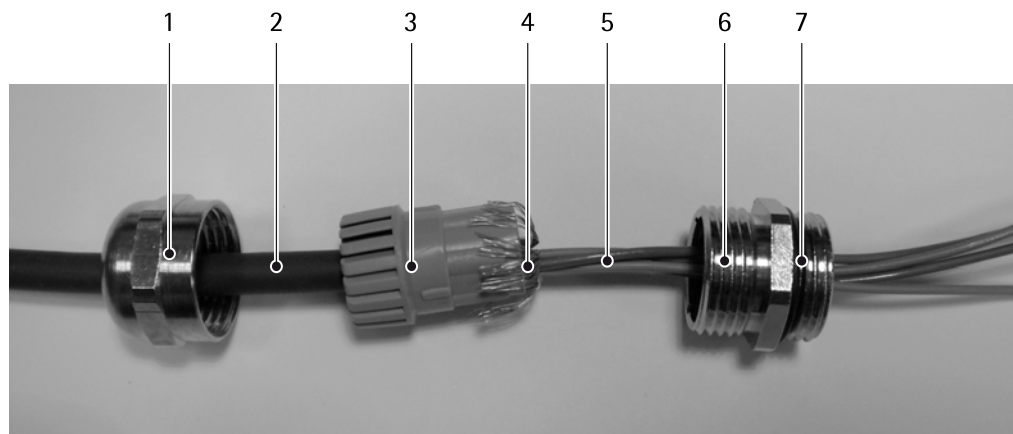

NOTICE

Material damage is possible.

Do not guide the screen (4) into the device!

- ▶ The cable shield (4) must be connected in the metal sleeve (6) of the cable gland.
- ▶ Before, during and after installation, make sure that the sealing ring is seated correctly.



1. Unscrew the sleeve screw cap (1).
2. Slide the cap (1) and plastic cone (3) onto the cable (2).
3. Guide the cable (5) through the gland (6).
4. Fold the cable shield (4) over the lower part of the terminal insert (3) (approx. 10 mm).
5. Connect the cable conductors.
6. Tighten the sleeve screw cap (1).
7. Secure the gland (6) including the o-ring (7) using the counter nut (in the housing).

NOTICE

Material damage is possible.

- ▶ Regularly check the cable gland for tightness and re-tighten it, if necessary.

4.3.3 Tightening torques

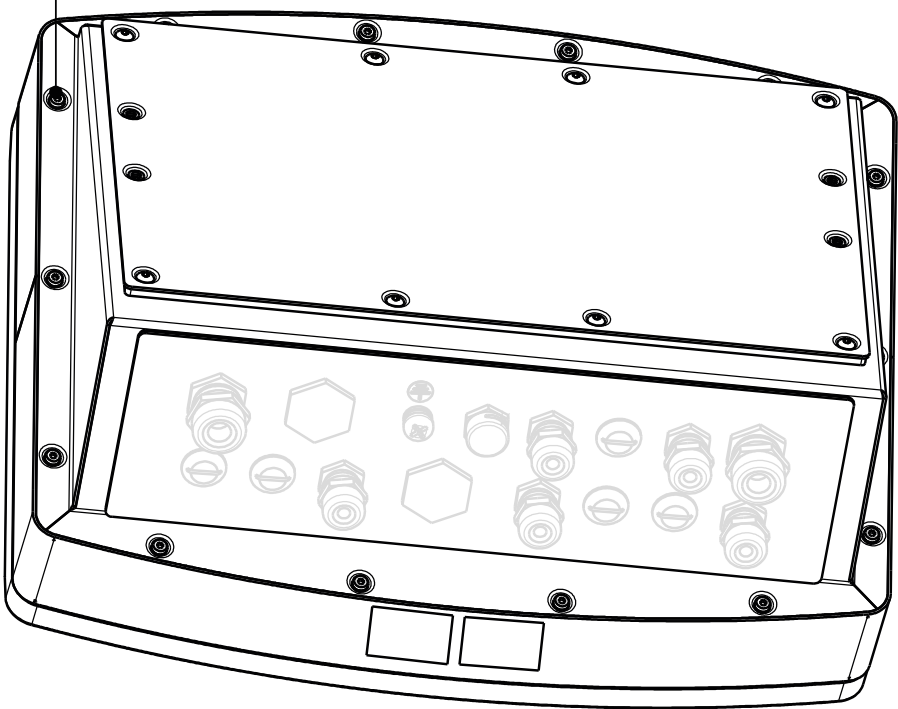
	No.	Tightening torque
	1a	0.45 Nm
	1b	0.20 Nm
		

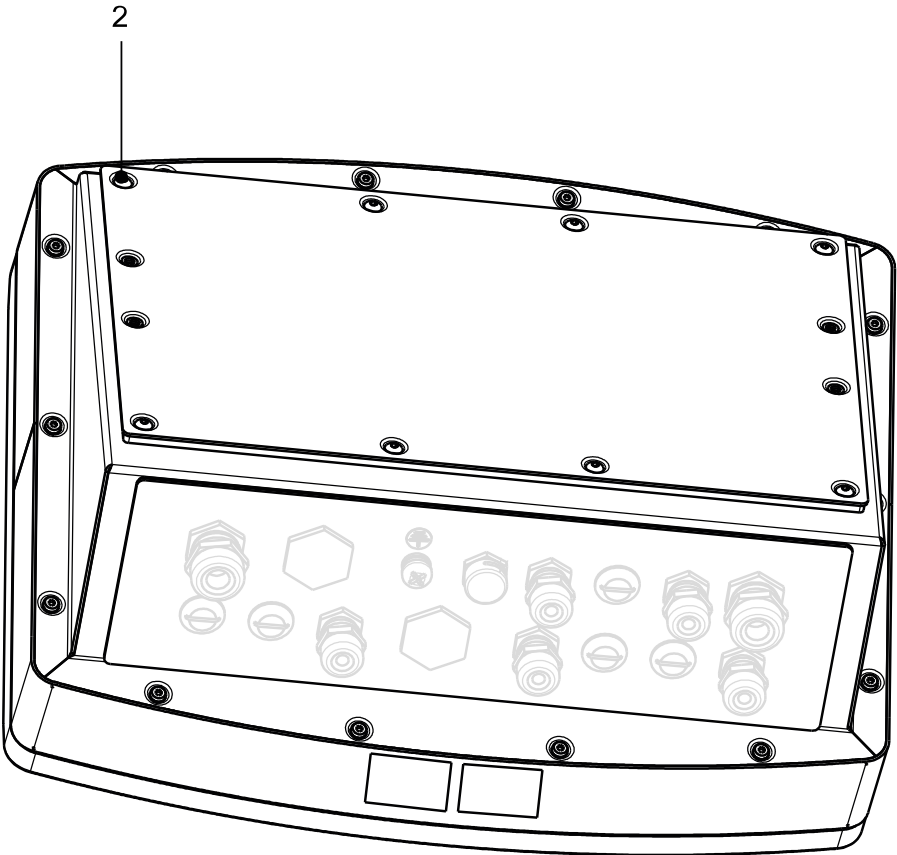
	No.	Tightening torque
	2	0.45 Nm

4.4 EMC-compliant installation

4.4.1 Connecting the screens to the screen clamping rail

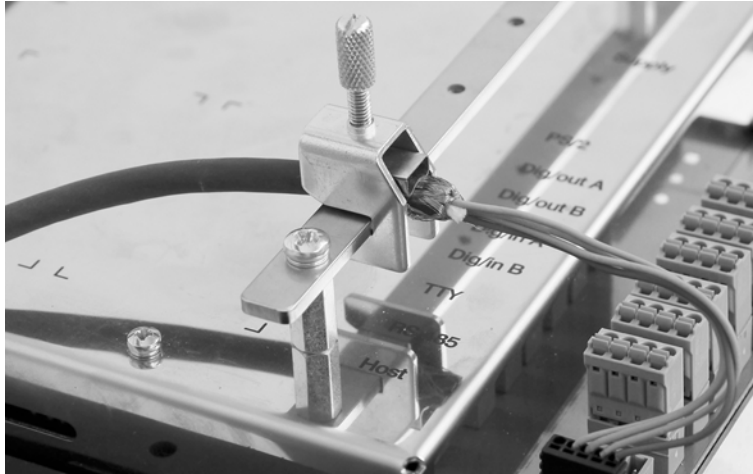

The screens must be connected to the screen clamping rail using cable clamps as pictured or the supplied screen terminals.

4.4.2 Connecting the equipotential bonding conductor

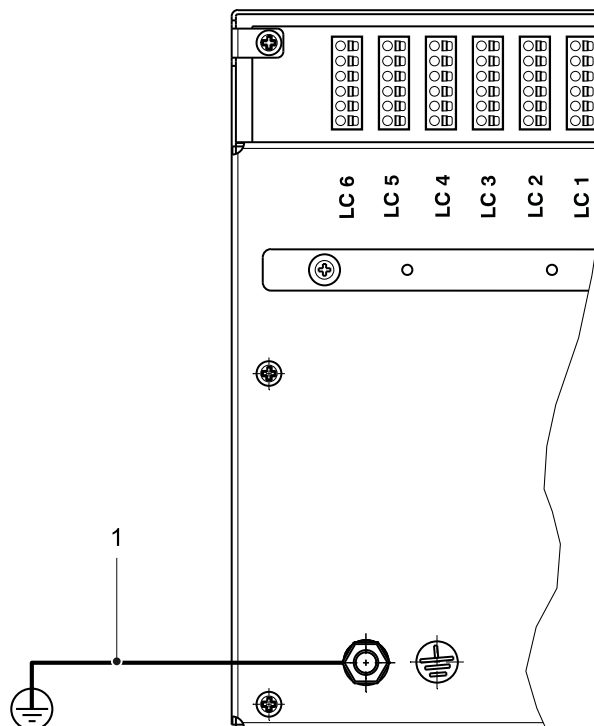

The equipotential bonding conductor (1) must be connected as pictured.

4.5 Hardware construction

4.5.1 Main board

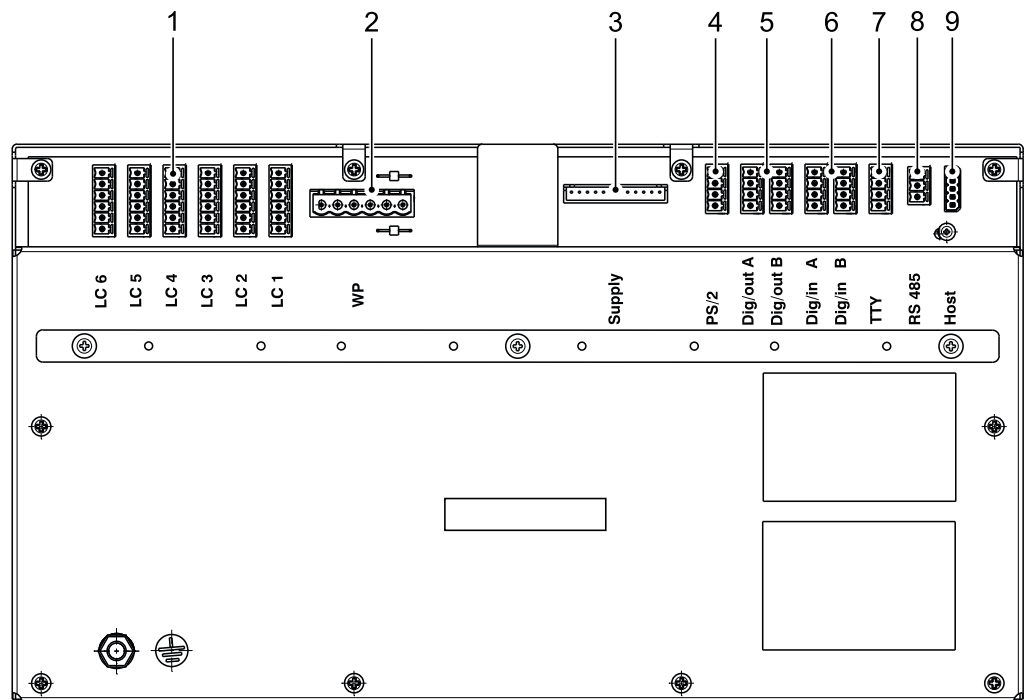

The following elements are located on the main board:

No.	Description
1	"LC 1" to "LC 6" connections for a maximum of 6 analog load cells with Ex approval
2	"WP" connection for the weighing electronics "WE1" in the Maxxis 5
3	"Supply" connection for the power supply
4	"PS/2" connection for the external PC keyboard with Ex approval
5	"Dig/out A" and "Dig/out B" digital outputs
6	"Dig/in A" and "Dig/in B" digital inputs
7	"TTY" connection for barcode scanners with Ex approval
8	"RS 485" connection for xBPI scale with Ex approval
9	"Host" connection for Maxxis 5

The color-graphic display is connected to the main board via a ribbon cable.

4.5.2 Maxxis 5 connection

A dedicated Ethernet connection (permanent point-to-point connection) is used for data transfer between Maxxis 5 ("Remote Terminal" interface) and the remote terminal ("Host" interface).

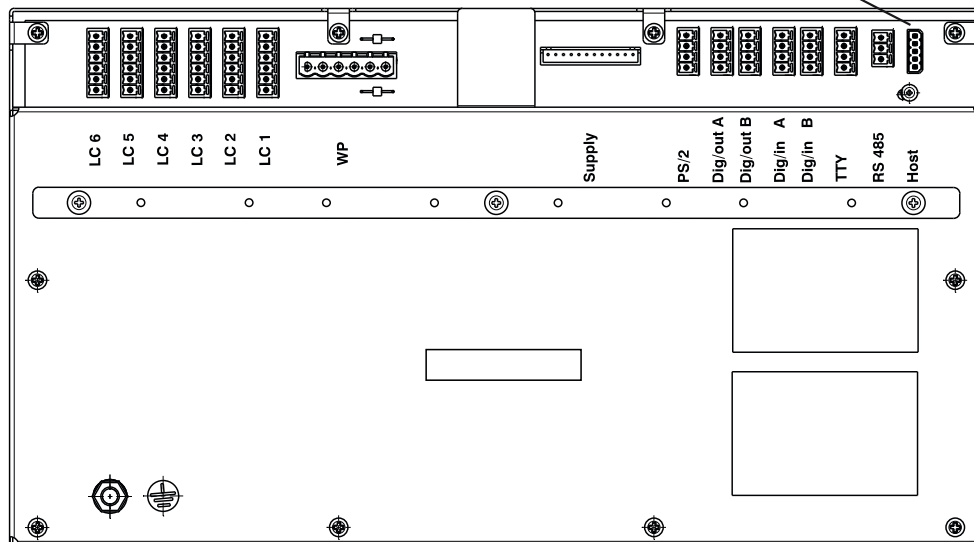
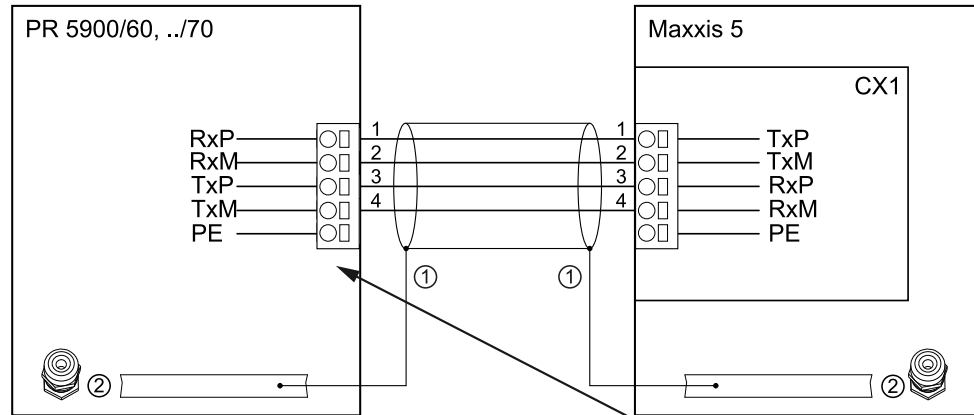

- ① Screen
- ② Screen clamping rail or cable gland

⚠ WARNING

Warning of hazardous area and/or personal injury

Using the intrinsically safe interface on a non-intrinsically safe device just once can impair and/or invalidate the protection type.

- ▶ Subsequent use in an intrinsically safe system is only then permitted following a thorough examination by qualified personnel; see also requirement as per IEC 60079-14.

Technical data

Description	Data
Connection	Terminal, 5-pin; clamping range 0.14–1.5 mm
Transfer rate	10 Mbits/s (10 Base-T), full duplex
Connection mode	Point to point
Potential isolation	Yes
Cable type	CAT5 S/FTP data cable, with 4 wires, braided, e.g., EtherLine®-P CAT. 5 2x2x24AWG
Cable impedance	100 Ω
Cable length to Maxxis 5	Max. 100 m
Ex connection values	See certificates on CD included and in the appendix to the Option CX1 additional information.

4.5.3 RS-485 interface

The device is equipped with an integrated RS-485 interface. Using this interface, it is possible to connect a platform scale with xBPI protocol.

Back, right

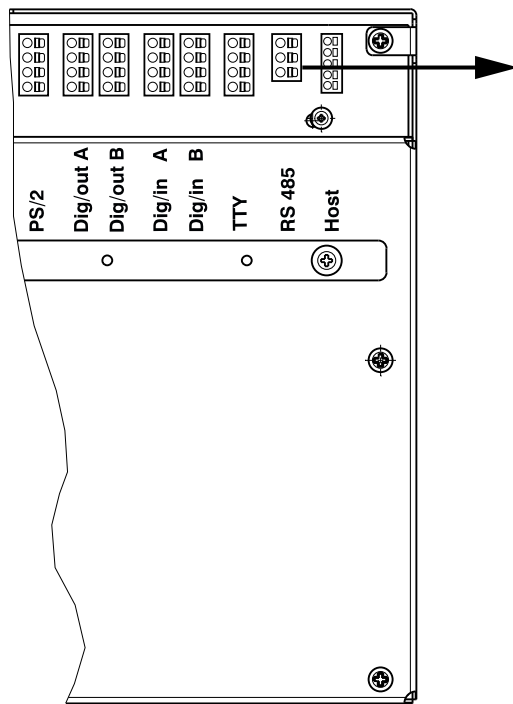

Block diagram RS-485

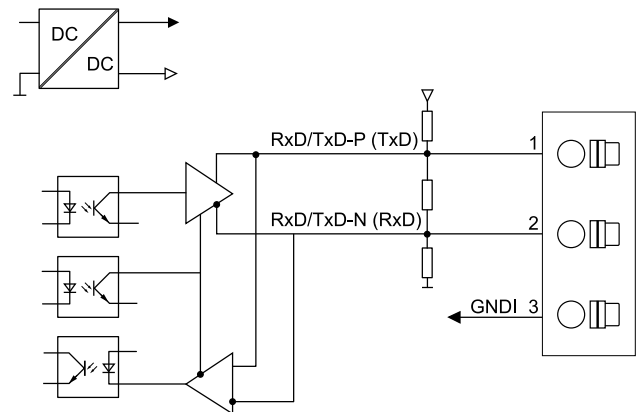

Technical data

Description	Data
Connection	Terminal, 3-pin; clamping range 0.2–1.5 mm ²
Number of channels	1
Type	RS-485, half duplex (2-wire)
Transfer rate	9600 Bit/s
Signals	RxD/TxD-P, RxD/TxD-N
Cable type	Twisted pair, screened (e.g., LifYCY 2x2x0.20), 1 pair of wires for ground (GND)
Cable length	max. 1000 m, see relevant manual for the platform scale
Ex connection values	See certificates on CD included

4.5.3.1 Connecting an IS platform via RS-485 (2-wire)

One IS platform scale approved for use in Ex areas with xBPI protocol can be connected via the RS-485 interface (2-wire).

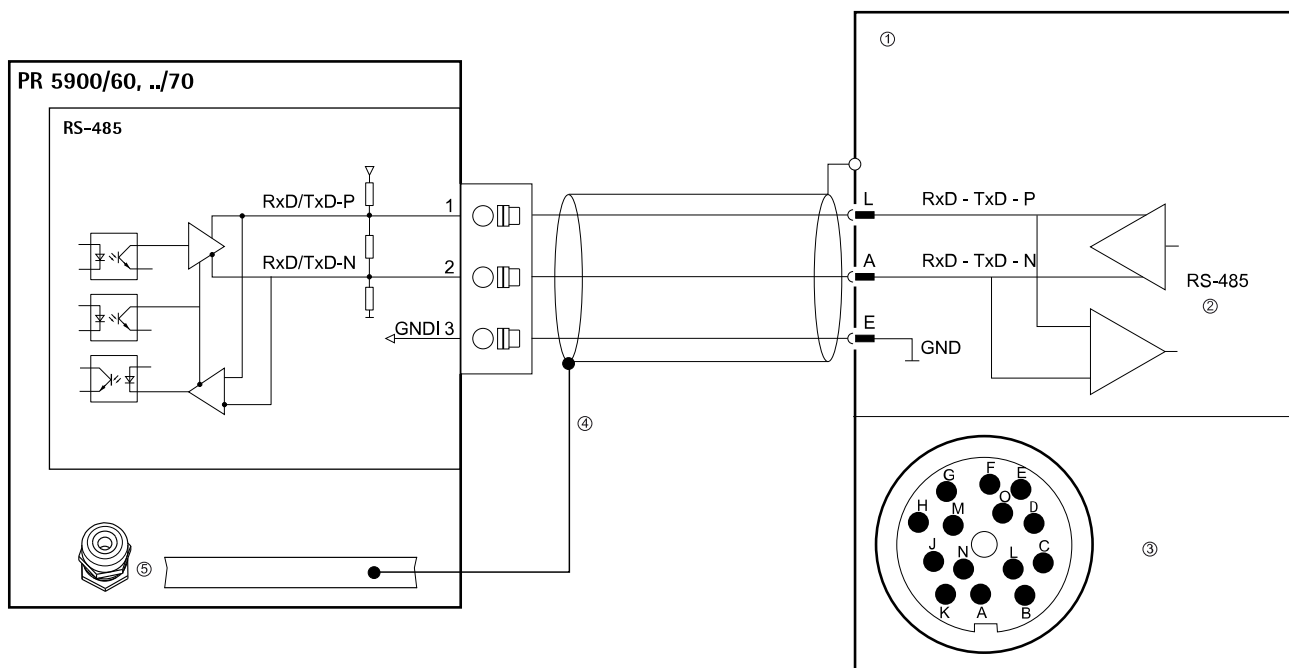

- ① IS platform xBPI protocol (slave)
- ② Half duplex
- ③ 14-pin male connector
- ④ Screen
- ⑤ Cable gland or screen clamping rail

Configuration PR 5900

[Operating] - [System setup] - [Weighing points] - [Weighing point X] - [xBPI scale] - [Interface] - [Remote terminal RS-485]

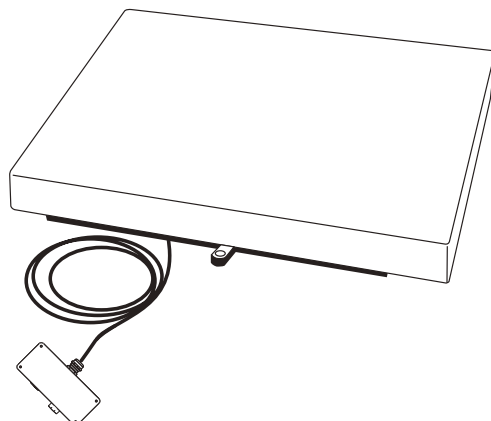
**Note:**

For further information, see the platform scale operating instructions.

4.5.4 TTY interface

The device is equipped with an integrated current loop interface.

A barcode scanner with Ex approval can be connected to this interface.

Technical data

Description	Data
Connection	Terminal, 4-pin; clamping range 0.2–1.5 mm ²
Number of channels	1
Type	TTY
Transmission rate [bit/s]	9600 bits/s
Number of databits	8
Parity	even
Signal high	18...22 mA
Signal low	0...1 mA
Number of signals	2
Potential isolation	no
Cable type	DatL-A4-0.75-0 4x0.75 mm ² ; ø7 mm; blue (Pepperl+Fuchs GmbH), only for connection to BOX-A9-PSCAN-F2-N
Cable length	Max. 150 m
Coding pin	is inserted into the position marked gray in the image (here pin 2)
Ex connection values	see barcode scanner operating manual

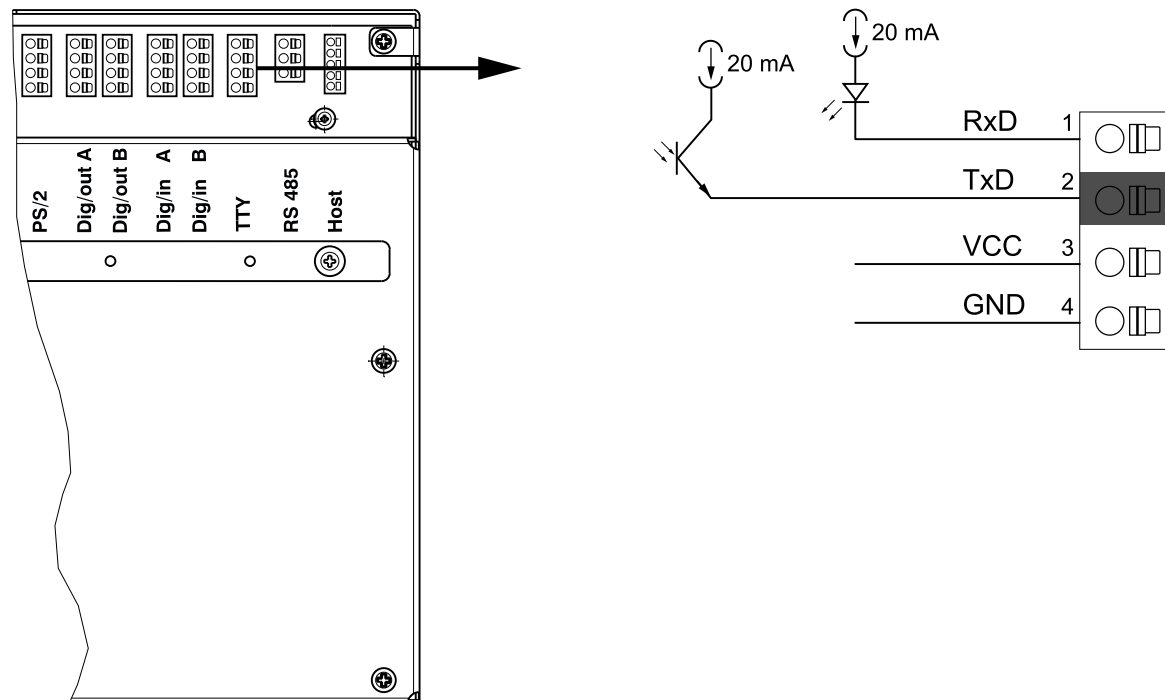
Back, right**Block diagram TTY****4.5.4.1 Connecting a barcode scanner with Ex approval**

BOX-A9-PSCAN-F2-N is connected to the barcode scanner PSCAN-D-1* (Pepperl+Fuchs GmbH) via the internal TTY interface.

No external power supply is required. Barcode scanner settings are made by scanning the corresponding code (see manual).

We recommend setting three redundant read processes to ensure secure read values. To confirm each read process via the key field, the automatic CR function of the scanner must be switched off.

⚠ DANGER

Danger of explosion!

Failure to observe instructions may result in personal injury or death.

- The equipotential bonding conductor of BOX-A9-PSCAN-F2-N absolutely must be connected to that of the installation (wire gage min. 4 mm², see manual).

Connecting to BOX-A9-PSCAN-F2-N

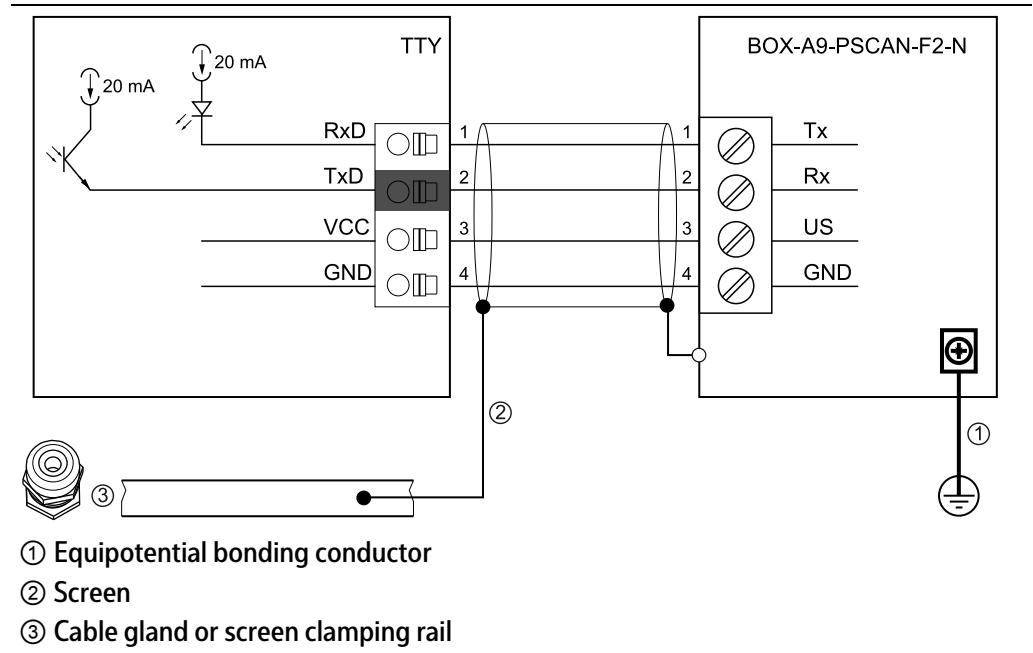

4.5.5 Digital inputs

4 active inputs are permanently built into the device for process control.

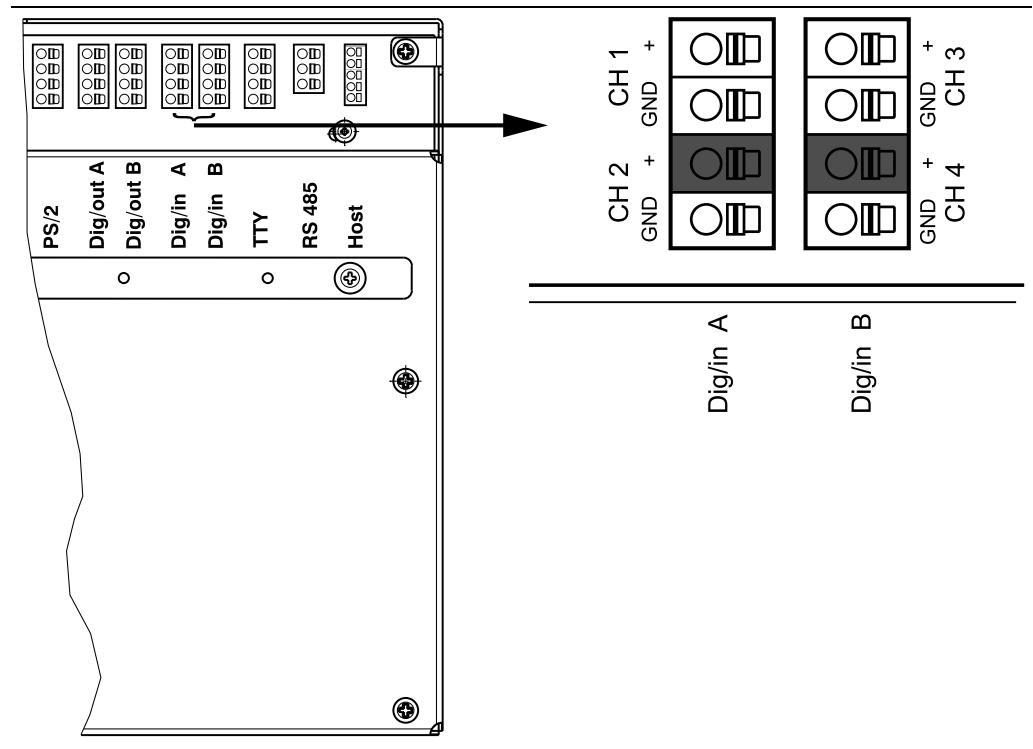

Technical data

Description	Data
Connection	2 x terminal, 4-pin; clamping area 0.2 to 1.5 mm ²
Number of inputs	4 (CH1, CH2, CH3, CH4)
Input, active	Can be switched to GND via a contact
Input current	< 5 mA
Input frequency	Max. 200 Hz (50% ratio)
Potential-free	No
Cables	Screened Connect the cable screen (wire gauge max. 1.5 mm ²) to the device screen clamping rail.
Cable length	Max. 150 m
Coding pin	Is inserted in the position marked in gray in the image
Connection values	See certificates on the CD included

Example:

Connection: Contact input "active"

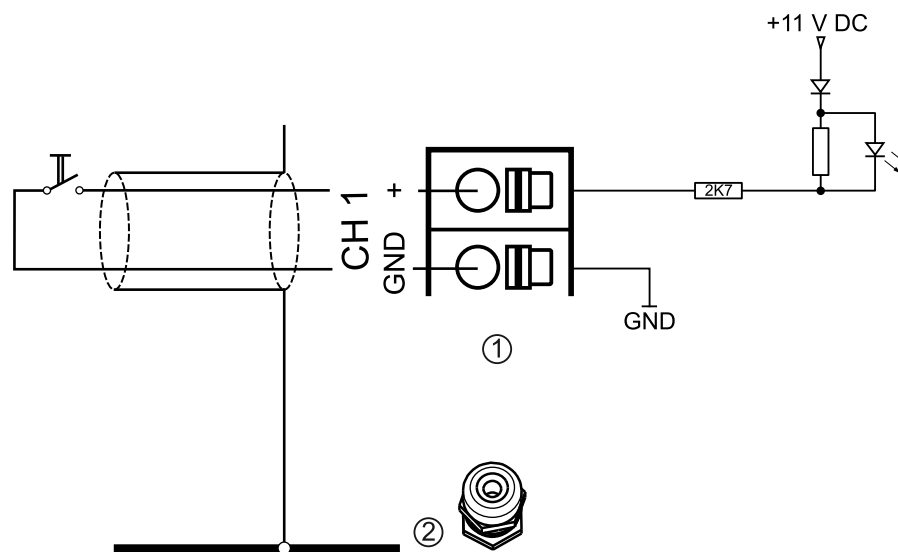

① Dig/in A

② Screen clamping rail or cable gland

4.5.6 Digital outputs

4 passive opto-decoupled outputs are permanently built into the device.
An external power supply is required.

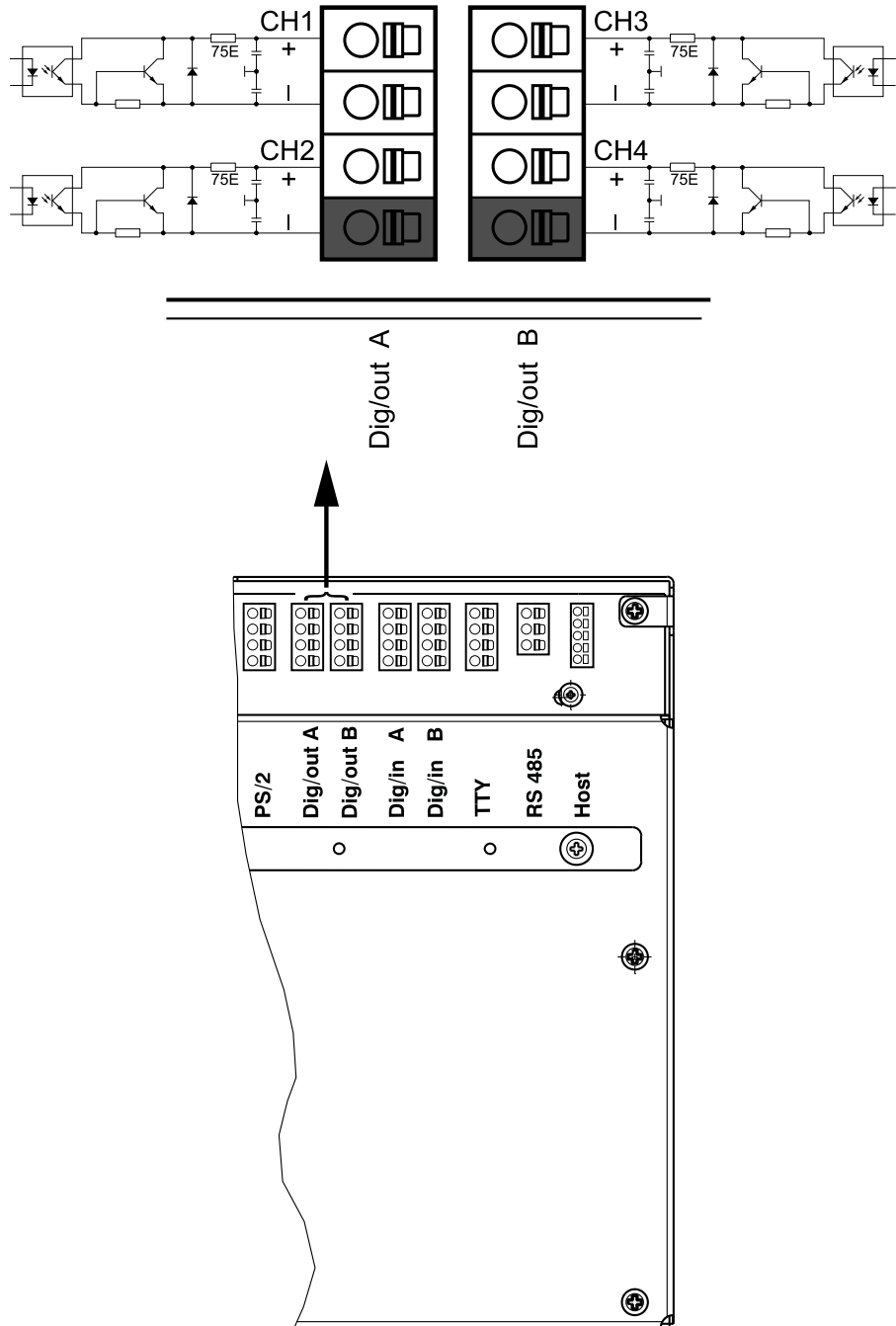

Technical data

Description	Data
Connection	2 x terminal, 4-pin; clamping area 0.2 to 1.5 mm ²
Number of outputs	4 (CH1, CH2, CH3, CH4)

Description	Data
Voltage drop	3.2 V @ I _{max}
Cables	Screened Connect the cable screen (wire gauge max. 1.5 mm ²) to the device screen clamping rail.
Cable length	Max. 150 m
Coding pin	Is inserted in the position marked in gray in the image
Connection values	See certificates on the CD included

4.5.7 PS/2 interface

The device is equipped with an integrated PS/2 interface.

An external PC keyboard with Ex approval can be connected to this interface.

Technical data

Description	Data
Connection	Terminal, 4-pin; clamping range 0.2–1.5 mm
Type	PS/2
Coding pin	is inserted into the position marked gray in the image (in this case pin 1)
Connection values	See external keyboard’s operating manual

Block diagram PS/2 Back, right

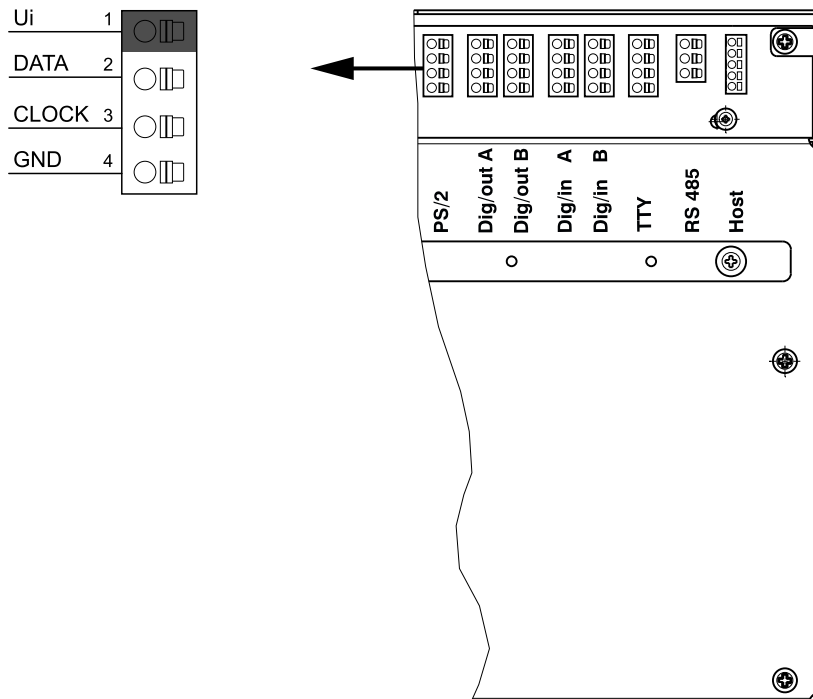

4.5.7.1 Connecting an external PC keyboard with Ex approval

The external PC keyboard with Ex approval, type EXTA2-* (Pepperl+Fuchs GmbH), can be connected via the PS/2 interface.

The remote terminal keypad and external keyboard are equivalent and either one can be used.

⚠ DANGER

Danger of explosion!

Failure to observe instructions may result in personal injury or death.

- ▶ The equipotential bonding conductor of the keyboard housing absolutely must be connected to that of the installation (wire gage min. 4 mm², see manual keyboard EXTA2-*).
- ▶ Option 1: Connection via connection cable screen (keyboard's scope of delivery).
- ▶ Option 2: Installation in a metal housing, which is connected to PE.

Connection to the external PC keyboard

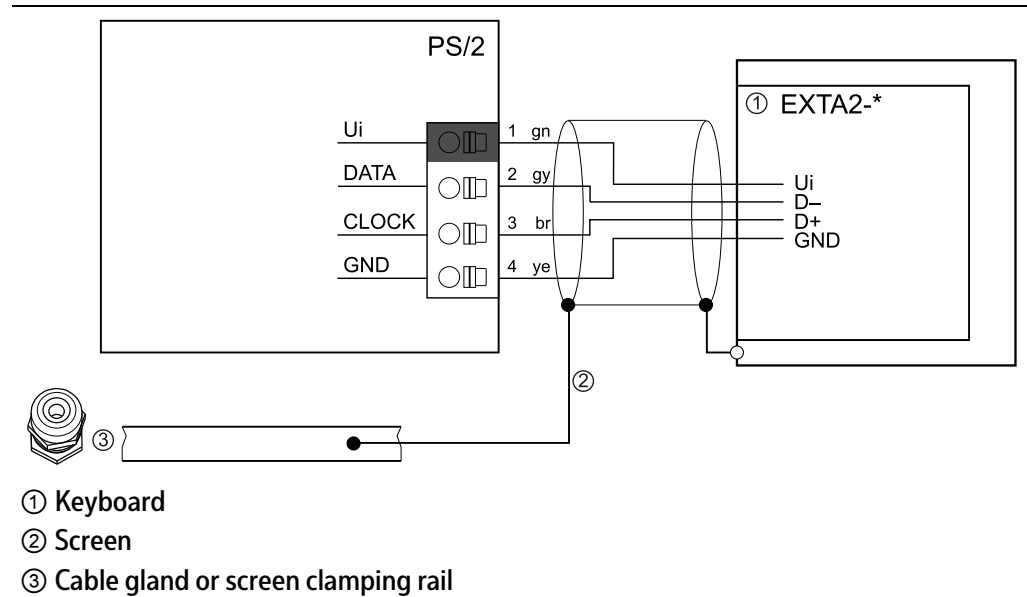

Keyboard layout



PC
key-
board



Keys F1 F2 ? MENU SK 1 SK 2 SK 3 SK 4 SK 5  START STOP

PC
key-
board



Keys EXIT C OK ▲, ▼, ◀, ▶

SK = Softkey

You can set the keyboard layout for the connected keyboard under menu item [Operating] - [System Setup] - [Operating Parameters] - [External Keyboard Layout] :

- [German QWERTZ]
- [French AZERTY]
- [Italian QWERTY]
- [Spanish QWERTY]
- [English QWERTY]
- [Russian QWERTY/йцукен]

4.5.8 Connecting power supply YPSC01-* (with Ex approval)

The remote terminal is supplied by power supply YPSC01-X (installed in Ex area) or YPSC01-Z (installed in the safe area).

The power supplies provide five intrinsically safe electrical circuits.

Electrical circuit	Connection
V1	LV4 1 and 2
V2	LV4 3 and 4
V3	LV4 5 and 6
V4	LV4 7 and 8
V5	LV4 9 and 10

Technical data

Description	Data
Connection	Terminal, 10-pin
Rated voltages	7.7 V and 10.9 V
max. cable length	50 m
Connection values	See certificates on CD included

Back, middle

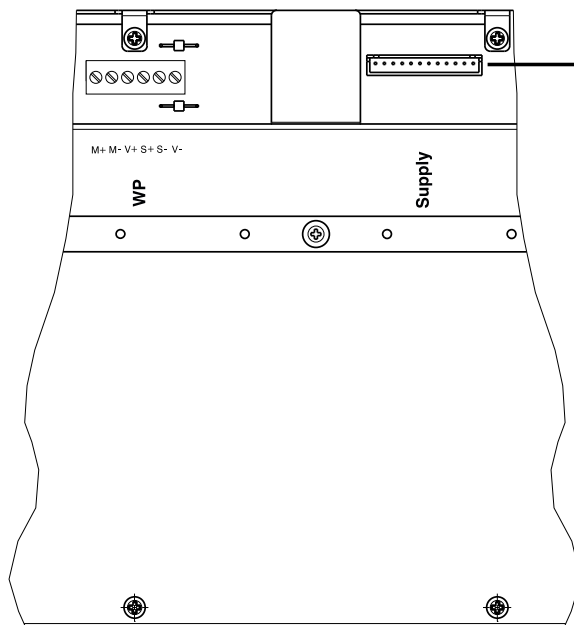

Connection

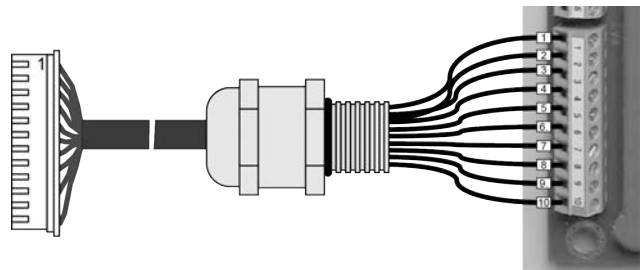

The plug supplied is inserted into the remote terminal ("Supply" connection). The individually numbered wires must be connected accordingly.

4.5.9 Connecting weighing electronics board "WE1" to Maxxis 5

The connection for the weighing electronics board WE1 is located on the back side of Maxxis 5.

Connecting cable PR 6136/.. must be used.

⚠ CAUTION

Warning of personal injury.

- ▶ The cable screen must be connected in the metal sleeve of the cable gland or to the screen clamping rail (Control Cabinet device), see also Option WE1 additional information.

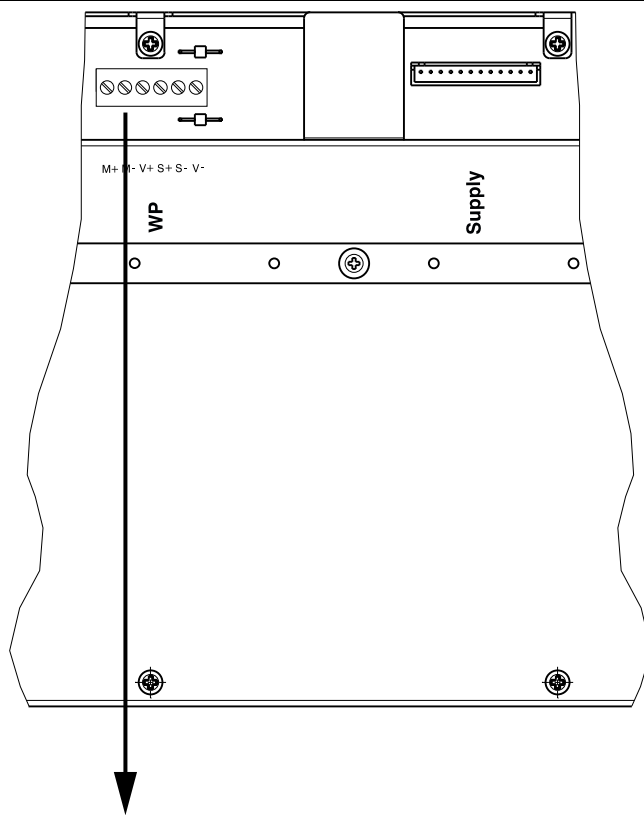

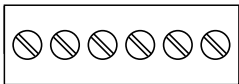
	Terminal	Connection	Description
 M+ M- V+ S+ S- V-	M+	+ Meas.	+ Signal/LC output
	M-	- Meas.	- Signal/LC output
	V+	+ Supply	+ Supply/excitation
	S+	+ Sense	+ Sense
	S-	- Sense	- Sense
	V-	- Supply	- Supply/excitation

4.5.10 Analog connections

There are connections for a maximum of 6 analog load cells on the housing rear panel.

Note:

Do not shorten the load cell cable. Connect the prepared cable end and roll up the remaining cable.

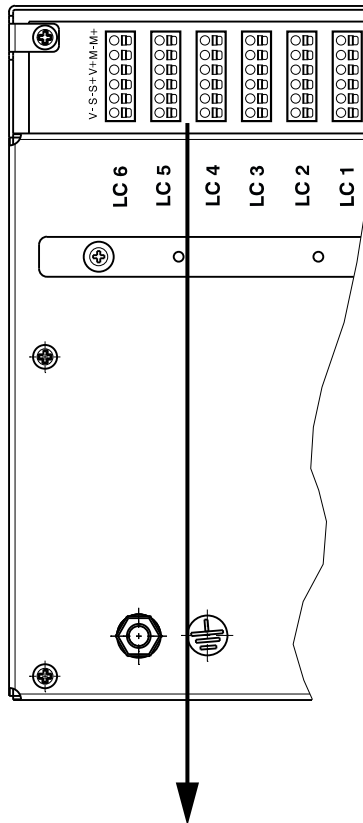

	Terminal	Connection (color)	Description
M+		gn green	+ Signal/LC output
M-		gy gray	- Signal/LC output
V+		rd red	+ Supply/excitation
S+		wh white	+ Sense
S-		bk black	- Sense
V-		bu blue	- Supply/excitation

4.5.11 Connecting a load cell with a 4-wire cable

- ① Link closed
- ② Link closed

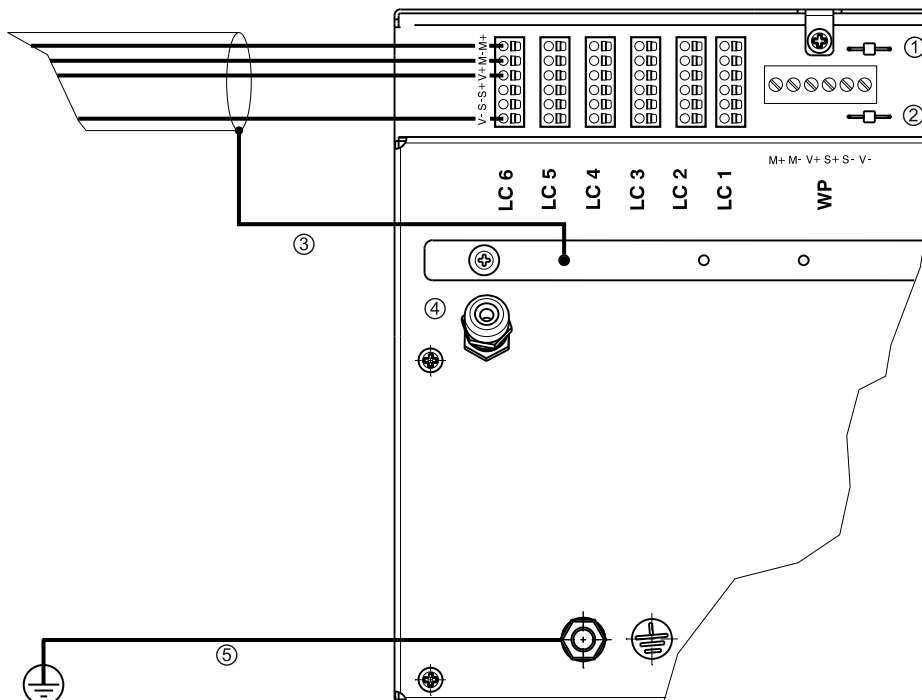

- ③ Screen
- ④ Screen clamping rail or cable gland
- ⑤ Equipotential bonding conductor

4.5.12 Connecting a load cell with a 6-wire cable

- ① Link open
- ② Link open

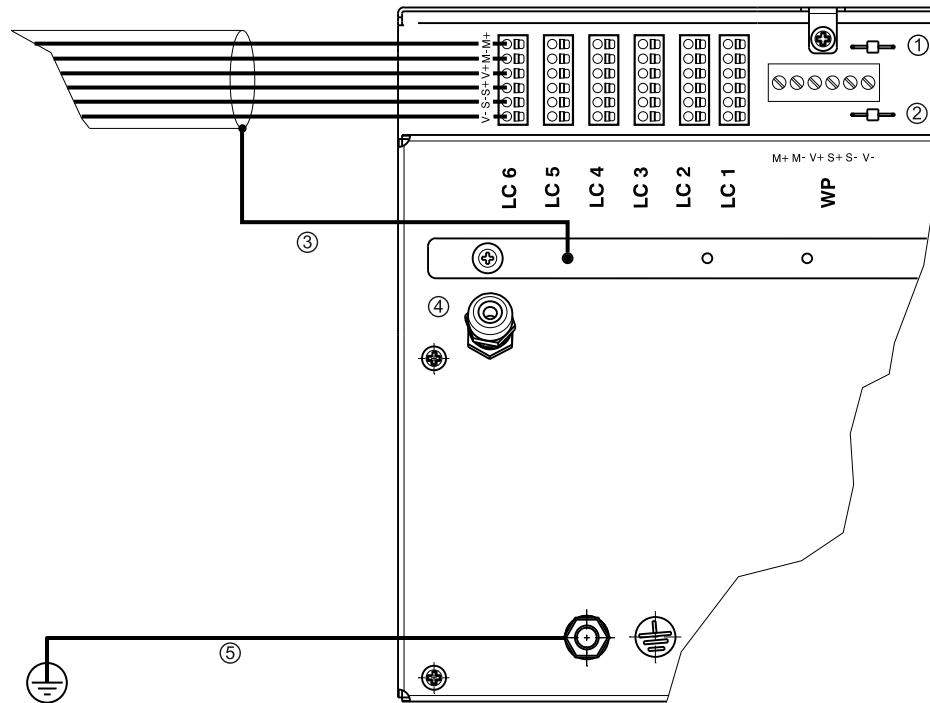

- ③ Screen
- ④ Screen clamping rail or cable gland
- ⑤ Equipotential bonding conductor

5 Getting started

5.1 Switching on the device

The Ex remote terminal can only be operated if the CX1 module is installed in the Maxxis 5. Data is transferred between the remote terminal and Maxxis 5 via a dedicated Ethernet connection (point-to-point permanent connection).

Before switching on the remote terminal for the first time, the installation must be complete.

No configuration is necessary to commission the device. Operation is the same as operation on the Maxxis 5; see the PR 5900 operating manual.

The Maxxis 5 can be operated (e.g. with blackbox housing):

- at the Maxxis 5 via USB key
- at the remote terminal via the external Ex keyboard
- on the remote terminal via keys on the front of the device
- on the Maxxis via network with the VNC program

The following display appears when the remote terminal is switched on.



Once the connection has been established, the screen content of the Maxxis 5 is displayed.

A connection can only be established during normal operation of the Maxxis 5.

Note:

It is not possible to display/operate the BIOS in the Maxxis 5 via the operator terminal.

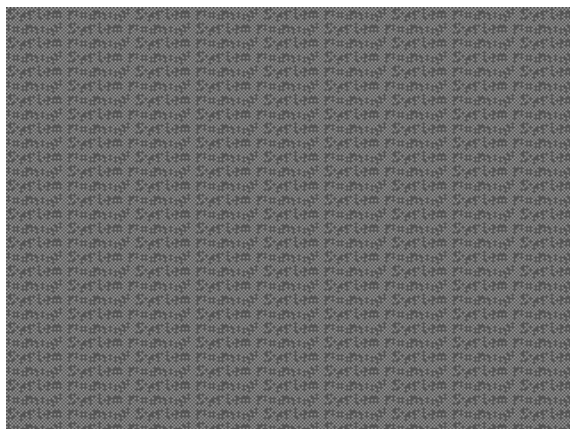

If it is not possible to establish a connection with the Maxxis 5, the display is "dimmed".

The symbol  appears on the Maxxis in the info line.

- Check that the Maxxis 5 is in normal operating mode and not in BIOS, for example.
- Check cable connections.



If the connection to the Maxxis 5 is interrupted, the display freezes and a message appears.

This can also happen if the Maxxis 5 is in BIOS (e.g. for a software update).

The symbol  appears in the status display on the Maxxis 5.

- Check that the Maxxis 5 is in normal operating mode and not in BIOS, for example.
- Check cable connections.

5.2 Assigning a specific Maxxis 5 and remote terminal

Requirement:

The remote terminal is in online mode, i.e. the screen content of the Maxxis 5 is displayed.

5.2.1 Procedure for operation in legal metrology

1. Calibrate the weighing point under menu item [Operating] - [System Setup] - [Weighing Points] - [Weighing Point x] - [Calibration] - [New], see PR 5900 instruction manual.
2. Select and save the W&M mode for operation in legal metrology via menu item [Operating] - [System Setup] - [Weighing Points] - [Weighing Point x] - [Parameters], see PR 5900 instruction manual.
3. Activate and save [Settings Locked].
 - ▷ Changes can no longer be made. The calibration check number is saved in the remote terminal and is used for comparison during the weighing process.

Note:

If the connection to the Maxxis 5 is interrupted when saving, the following warning message is displayed:

Warning:

The adjustment check number could not be saved in the remote terminal. Please connect a remote terminal and press "Retry".

Ignoring this problem will cause a weighing point error when connecting the remote terminal at a later stage.

If a remote terminal is connected without the calibration check number or with a calibration check number that differs from the one used during allocation, the following will be displayed:

wrong remote terminal

This can only be rectified by

- connecting the Maxxis to the assigned remote terminal
- deactivating the [Settings Locked] parameter so that a new calibration check number can be saved.

This may be necessary if a defective remote terminal needs to be replaced.

5.2.2 Procedure for operation in non-legal metrology

- ▶ Calibrate the weighing point under menu item [Operating] - [System Setup] - [Weighing Points] - [Weighing Point x] - [Calibration] - [New], see PR 5900 instruction manual.
 - ▷ The calibration check number is always saved in the remote terminal. Changes are possible. A new check number is saved after each save.

5.3 Switching off the device

Switching off the device, refer to the PR 5900 operating manual.

6 Repairs and maintenance

6.1 Repairs

Repairs are subject to inspection and must be carried out at Minebea Intec.

In case of defect or malfunction, please contact your local Minebea Intec dealer or service center for repair.

When returning the device for repair, please include a precise and complete description of the problem.

⚠ WARNING

Possible explosion due to improper replacement!

- ▶ It is not permissible to change fuses in Ex devices!

6.2 Maintenance

Maintenance work may only be carried out by a trained technician with expert knowledge of the hazards involved and the required precautions.

6.3 Soldering work

Soldering work on the device is neither required nor permitted.

6.4 Cleaning

NOTICE

Property damage caused by unsuitable cleaning utensils/agents.

Damage to the device.

- ▶ Prevent moisture from penetrating the interior.
- ▶ Do not use aggressive cleaning agents (solvents or similar agents).
- ▶ For use in the food industry, use a cleaning agent suitable for that particular working environment.
- ▶ Use soft sponges, brushes and cloths.
- ▶ Spraying with water or blasting with compressed air is not permitted.

1. Unplug device from mains supply, disconnect any data cables.
2. Clean the device with a cloth lightly moistened with a soap solution.
3. Wipe down the device with a soft, dry cloth after cleaning.

7 Disposal

Our products and their packaging should not be disposed of in municipal waste (e.g. garbage can for recyclable packaging, garbage can for paper packaging, etc.). They can either be recycled by the customer themselves, providing this complies with requirements set out by electrical or electronic waste or packaging waste laws, or sent back to Minebea Intec at a charge.

This option of returning the product is intended to provide proper recycling or reuse in a manner that is collected separately from municipal waste.

Before disposing of or scrapping the old products, any single-use or rechargeable batteries should be removed and taken to a suitable collection point. The type of battery used is specified in the technical data.

Please see our General Terms and Conditions for further information.

Service addresses for repair acceptance and collection points can be found on the product information enclosed with the product as well as on our website (www.minebea-intec.com).

Should you have any further questions, please contact your local service representative or our service center.

Minebea Intec GmbH

Repair center

Meiendorfer Strasse 205 A

22145 Hamburg, Germany

Phone: +49.40.67960.333

service.HH@minebea-intec.com

We reserve the right not to accept products that are contaminated with hazardous substances (ABC contamination).

8 Error correction

8.1 Connection to the Maxxis 5 is interrupted



If the connection to the Maxxis is interrupted,

- the display is "frozen" and a message is displayed.
- the digital outputs are reset.

The symbol  appears in the status display on the Maxxis 5.

1. Check that the Maxxis 5 is in normal operating mode and not in, e.g. BIOS.
2. Check cable connections.

9 Technical data

9.1 Decoding the serial number

30 252 00015		
30	252	00015
Location no.: 30 = Hamburg	Code for the year/month: 252* = April 2010	Current number

* Is increment according to the year group table of Minebea Intec.

9.2 General data

The following characteristics are valid after a warm-up time of at least 60 minutes (reference temperature 23 °C).

Connection for the Ex area	Via the CX1 module in the Maxxis 5; see also Option CX1 additional information
Ex connection values	See certificates on the CD included and Option CX1 additional information

9.2.1 Display

Type	Size	Display
TFT color display	5.7"	320 x 240 pixels

9.3 Possible marking for the Ex area

Zone	Marking	Certificate no.
1	II 2 G Ex ib IIC T4 Gb Ex ib IIC T4 Gb	DEKRA 14ATEX0017X IECEX DEK 14.0002X
21	Only for PR 5900/70: II 2 D Ex ib Db IIIC T80 °C Db Ex ib IIIC T80 °C Db	DEKRA 14ATEX0017X IECEX DEK 14.0002X

NOTICE

Installation in the Ex area

- For installation in the Ex area, it is essential that the Ex safety instructions on the PR 5900 CD are observed.

9.4 Effect of ambient conditions

9.4.1 Ambient conditions

Temperature range	
Ambient temperature for operation	-10...+50 °C
Ambient temperature "verifiable"	-10...+50 °C
Ambient temperature in Ex areas	
Power-on temperature	>0°C
Limits for storage/transport	-20...+70 °C
Moisture	<95%, non-condensing (acc. to IEC 60068-2)
Protection class	
Control cabinet housing	IP65, back IP20
Table-top housing	IP65
Altitude	<2000 m

9.4.2 Electromagnetic Compatibility (EMC)

Interference resistance in compliance with EN 61326 (industrial sector)

9.4.3 RF interference suppression

Interference emission		pursuant to EN61326 (EN 55011 limit class A, for industrial areas)
-----------------------	---	--

9.5 Mechanics

9.5.1 Design

Control cabinet housing made of stainless steel

Table-top housing made of stainless steel

9.5.2 Dimensions

See Chapter [3.3.1](#).

9.5.3 Weights

Type	Net weight	Shipping weight
Control cabinet housing	3.0 kg	Approx. 4.0 kg
Table-top housing	5.7 kg	Approx. 6.7 kg

9.6 Documentation on the CD included

The documents and manuals listed in the appendix (see Chapter [10.1](#)) can be found on the PR 5900 CD.

10 Appendix

10.1 Certificates/control drawing/safety instructions

Ser. no.	Description	Document no.
1	EC-Type Examination Certificate	DEKRA 14 ATEX 0017 X
2	Certificate of Conformity	IECEX DEK 14.0002 X
3	EU-Declaration of Conformity	MEU17033
4	Safety instructions	940515900000-460
5	Control drawing	2004137

The documents listed in the table can be found on the PR 5900 CD.

Published by
Minebea Intec GmbH | Meiendorfer Strasse 205 A | 22145 Hamburg, Germany
Phone: +49.40.67960.303 | Email: info@minebea-intec.com
www.minebea-intec.com

