

Operating Instructions

Process Controller Maxxis 5 PR 5900



Translation of original operating instructions

9499 050 59900

Edition 6.9.0

07/11/2022

Release 2.26.xx-Exx

Foreword

Must be followed!

Any information in this document is subject to change without notice and does not represent a commitment on the part of Minebea Intec unless legally prescribed. This product should only be operated/installed by trained and qualified personnel. In correspondence concerning this product, the type, name, and release number/serial number as well as all license numbers relating to the product have to be cited.

Note

This document is partially protected by copyright. It may not be changed or copied, and it may not be used without purchasing or written permission from the copyright owner (Minebea Intec). The use of this product constitutes acceptance by you of the abovementioned provisions.

Table of contents

1	Introduction.....	6
1.1	Read the manual.....	6
1.2	This is what operating instructions look like.....	6
1.3	This is what lists look like.....	6
1.4	This is what menu items and softkeys look like.....	6
1.5	This is what the safety instructions look like.....	6
1.6	Hotline.....	7
2	Getting started	8
2.1	Display and operating elements	8
2.1.1	Overview.....	8
2.1.2	Display elements.....	8
2.1.3	Operating elements.....	12
2.1.4	Display and operation using VNC client.....	18
2.2	Data security and data storage	18
2.2.1	Power failure.....	19
2.2.2	Warm start.....	19
2.2.3	Cold start.....	19
2.3	Switching on the device.....	20
2.4	Switching off the device	21
2.5	Device warm-up time.....	21
2.6	Operating via front-panel keys/PC keyboard.....	21
2.7	Overwrite protection.....	21
2.7.1	CAL switch.....	21
2.7.2	Software	23
2.8	Switching on blackbox device	25
2.8.1	Connecting to remote terminal PR 5900/6x, ../7x.....	25
2.8.2	Network settings.....	25
2.8.3	Connecting to notebook/PC	26
2.9	Operating via a notebook/PC.....	27
2.9.1	Finding and connecting the device automatically in the network	27
2.9.2	Finding and connecting a device with a notebook/PC	27
2.9.3	Searching the device in the network with "IndicatorBrowser"	28
2.9.4	Resetting the network address.....	30
2.9.5	Operation using VNC.....	30
3	Operation and control.....	32
3.1	User login/logout	32
3.1.1	User login	32
3.1.2	User Logout	33
3.2	User management.....	33

3.3	Selecting the operating language.....	34
3.4	System menu.....	34
3.5	Help functions	36
3.6	Alibi memory	36
3.7	Showing the calibration data.....	37
3.8	Increased resolution (10-fold) of the weight value	37
3.9	Functions via the website.....	38
3.9.1	Browse database.....	39
3.9.2	Browsing the Alibi memory.....	39
3.9.3	Displaying manuals	40
3.9.4	Browse the event log.....	40
3.9.5	Browse log files	41
3.9.6	Displaying a log of the last system error.....	41
3.9.7	Screenshot	42
3.9.8	Export database	42
3.9.9	Export Alibi memory.....	43
3.9.10	Export service report.....	43
3.9.11	Backup and restore setup data.....	44
3.9.12	Loading language files.....	46
3.10	BIOS BOOT menu	47
3.10.1	Open BIOS BOOT menu	47
3.10.2	BIOS BOOT menu in blackbox device.....	53
3.10.3	System messages in blackbox device.....	54
4	System setup.....	55
4.1	Connected devices	56
4.1.1	Remote display.....	56
4.1.2	ModBus-RTU master	58
4.1.3	PC via EW-Com.....	60
4.1.4	Printer	62
4.1.5	Remote terminal	70
4.1.6	Barcode scanner (with Ex approval).....	70
4.2	Date & time	72
4.3	Operating parameters	74
4.4	Network parameters	79
4.5	Network share connections	82
4.5.1	Add	83
4.5.2	Change.....	85
4.5.3	Remove.....	86
4.6	Fieldbus parameters	87
4.6.1	Fieldbus settings for the SPS	89
4.7	Weighing points.....	89
4.7.1	Internal weighing point.....	92

4.7.2	Liquid counter	124
4.7.3	User scale	127
4.7.4	A+B (scale).....	131
4.7.5	xBPI scale	133
4.7.6	SBI scale.....	161
4.7.7	Pendeo Truck.....	165
4.7.8	Pendeo Process.....	191
4.7.9	PR-Net weighing point	219
4.7.10	Mettler-Scale	221
4.7.11	SMA scale	226
4.8	Display settings.....	230
4.9	License settings	231
4.9.1	Application license.....	232
4.9.2	Demo mode	233
4.9.3	Default (restoring factory settings).....	234
4.10	User management.....	235
4.10.1	Create user	237
4.10.2	Copy user.....	240
4.10.3	Change user settings.....	241
4.10.4	Remove user	243
4.10.5	Deactivate user management.....	244
4.10.6	Error logging in	245
4.11	Alibi memory	246
4.11.1	Tidy up records.....	248
4.11.2	Delete.....	249
5	System information.....	251
5.1	Show version	252
5.2	Show status	253
5.3	Show alarm information	254
5.4	Show HW options	255
5.5	Show ModBus-TCP I/O module	257
5.6	Browsing the Alibi memory.....	258
5.6.1	Search for specific date in Alibi memory.....	259
5.6.2	Search for a given sequence number	262
5.6.3	Status Alibi memory	263
5.7	Show calibration check number	264
5.8	Show Pendeo data.....	265
5.9	Show event log.....	267
5.10	Print configuration settings.....	269
6	System maintenance	271
6.1	Backup.....	272

6.1.1	SD card.....	273
6.1.2	USB stick.....	275
6.1.3	Shared directory.....	277
6.2	Restore	279
6.2.1	SD card.....	281
6.2.2	USB stick.....	283
6.2.3	Shared directory.....	286
6.3	Export	289
6.3.1	USB stick.....	290
6.3.2	Shared directory.....	292
6.4	Import.....	294
6.4.1	USB stick.....	296
6.4.2	Shared directory.....	299
6.5	Alibi memory maintenance	302
6.5.1	Export selection of records.....	303
6.5.2	Export + tidy up selection of records	306
6.5.3	Print selection of records.....	311
6.5.4	Print + tidy up selection of records	314
6.6	SD card maintenance	317
6.6.1	Format SD card.....	317
6.6.2	Cleanup backups.....	319
6.7	Create service report.....	320
6.8	Shutdown & power off.....	322
6.8.1	Shutdown & Power off (without SD card).....	323
6.9	Update software	324
6.9.1	Update (soft key).....	324
6.9.2	Update software.....	326
6.9.3	Update software with FlashIt	336
6.9.4	Update software for remote terminal.....	338
6.9.5	Remove application.....	339
6.9.6	Restore software from SD card.....	340
6.10	Factory reset.....	341
6.11	Test hardware.....	342
6.11.1	Display test.....	343
6.11.2	Keyboard test	344
6.11.3	I/O cards test	345
7	ModBus protocol	354
7.1	General description	354
8	Fieldbus interface	355
8.1	General notes	355
8.2	Scale protocol.....	355

8.2.1	Data exchange range	356
8.2.2	Reading and writing data with function numbers.....	358
8.2.3	Reading and writing bits directly	360
8.2.4	Waiting for the result of the action	360
8.2.5	Function numbers.....	360
8.2.6	Example: reading the gross weight.....	365
8.2.7	Special note for DeviceNet and EtherNet IP	366
8.3	SPM protocol.....	366
8.3.1	Data exchange range	366
8.3.2	Function numbers.....	367
8.3.3	Error code.....	368
8.3.4	Data exchange modes.....	369
9	Error messages	372
9.1	Error messages measuring circuit.....	372
9.2	Error messages for xBPI scales.....	373
9.3	Error messages for Pendeo load cells	374
9.4	Error messages at PR-Net weighing point	375
9.5	Error messages at "Mettler-Scale" weighing point.....	375
9.6	Warnings when assigning a weighing point.....	375
9.7	Error messages during calibration.....	375
9.7.1	Determine MAX (maximum capacity)	376
9.7.2	Determining the scale interval.....	377
9.7.3	Determining the dead load	377
9.7.4	Calibrating with weight.....	378
9.8	Error status in "LAST_ERROR"	378
10	Printouts.....	380
10.1	Configuration printout.....	380
10.2	Test printout.....	384
10.3	Alibi printout	385

1 Introduction

1.1 Read the manual

- Please read this manual carefully and completely before using the product.
- This manual is part of the product. Keep it in a safe and easily accessible location.

1.2 This is what operating instructions look like

1. - n. are placed before steps that must be done in sequence.
 - ▶ is placed before a step.
 - ▷ describes the result of a step.

1.3 This is what lists look like

- indicates an item in a list.

1.4 This is what menu items and softkeys look like

[] frame menu items and softkeys.

Example:

[Start]- [Applications]- [Excel]

1.5 This is what the safety instructions look like

Signal words indicate the severity of the danger involved when measures for preventing hazards are not followed.

DANGER

Warning of personal injury

DANGER indicates death or severe, irreversible personal injury which will occur if the corresponding safety measures are not observed.

- ▶ Take the corresponding safety precautions.

WARNING

Warning of hazardous area and/or personal injury

WARNING indicates that death or severe, irreversible injury may occur if appropriate safety measures are not observed.

- ▶ Take the corresponding safety precautions.

CAUTION

Warning of personal injury.

CAUTION indicates that minor, reversible injury may occur if appropriate safety measures are not observed.

- ▶ Take the corresponding safety precautions.

NOTICE**Warning of damage to property and/or the environment.**

NOTICE indicates that damage to property and/or the environment may occur if appropriate safety measures are not observed.

- ▶ Take the corresponding safety precautions.
-

Note:

User tips, useful information, and notes.

1.6 Hotline

Phone: +49.40.67960.444

Fax: +49.40.67960.474

eMail: help@minebea-intec.com

2 Getting started

2.1 Display and operating elements

2.1.1 Overview

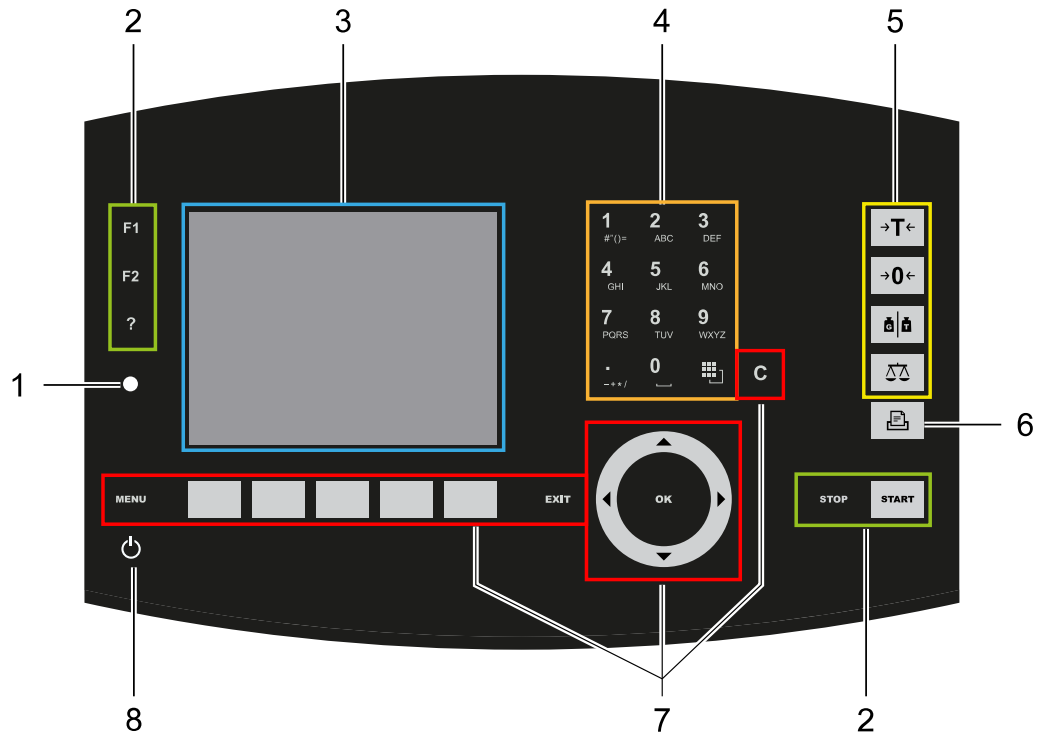

No.	Name
Display elements	
1	LED status display, see Chapter 2.1.2.2
3	5.7" TFT color display, see Chapter 2.1.2.1
Operating elements, see Chapter 2.1.3.1	
2	Function keys
4	Alphanumeric keypad
5	Indicator keys
6	Application keys
7	Navigation/menu keys, incl. soft keys
8	On/off button

2.1.2 Display elements

- TFT screen display, see Chapter [2.1.2.1](#)
- LED status display, see Chapter [2.1.2.2](#)

2.1.2.1 TFT user interface display





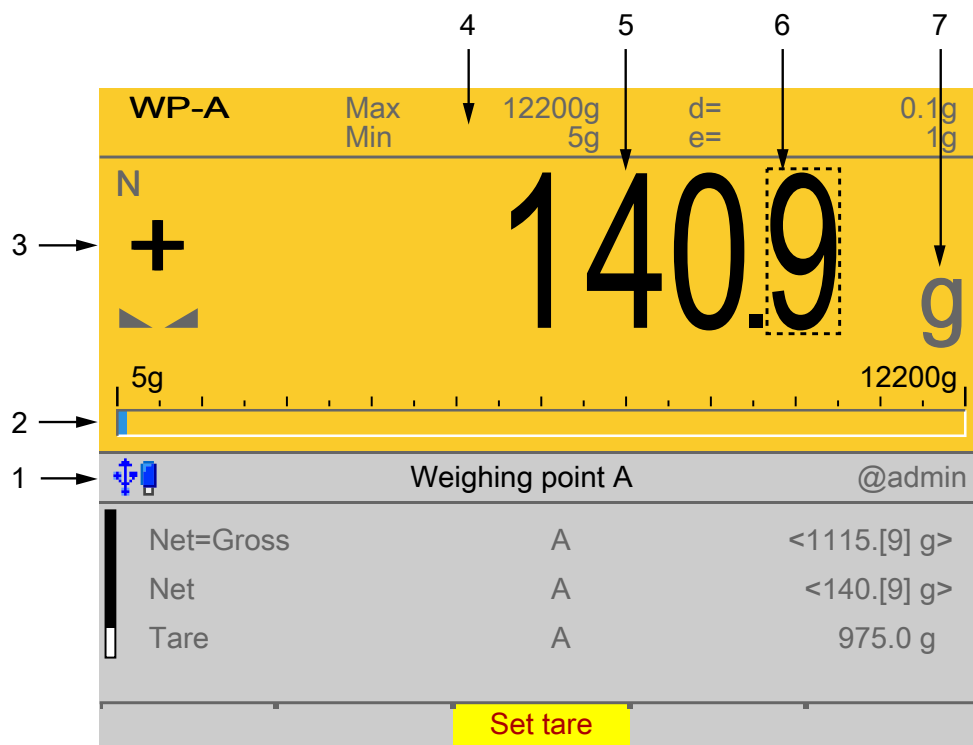

The TFT color graphics display can show weight values of up to 7 digits with decimal point and plus or minus sign. The available mass units are t, kg, g, mg, lb, or oz.

The lb and oz units are not permitted for use in legal metrology in the EU and EEC.

Below the weight display, the currently displayed weight is shown in a bar graph that indicates the percentage of the maximum capacity (Max). 0 is on the left, and 100% on the right.











No.	Description
1	Info line
2	Bar graph
3	Weight type/plus or minus sign/standstill
4	Status display
5	Weight value
6	Border around decimal place
7	Symbols/mass unit

Weight type/plus or minus sign	Description
B	Gross weight
G	Gross weight in NTEP or NSC mode
N	Net weight (Net = gross - tare)
T	Tare weight
PT	Preset tare, not tared
No display	- Test value - Gross, not tared
User	Additional weight display, application-dependent
Setp	Additional weight display, application-dependent
Diff	Additional weight display, application-dependent
+	Positive value
-	Negative value
<hr/>	
Standstill/zero/batching/monitoring	Description
	Weight value standstill
	The gross weight value is within $\pm 1/4$ d of zero
	Batching mode: flashes when batching is "stopped"; rapid flashing indicates "error status"
	Pendeo load cells: Plausibility monitoring; the average deviation of the individual load cells is calculated
	Pendeo load cells: Temperature monitoring; 1–n load cells above or below permissible temperature
<hr/>	
Symbols/mass unit	Description
	Value not permissible in legal metrology (e.g., 10x resolution, deactivated load cell)
R1	Range 1
R2	Range 2
R3	Range 3
WP A	Weighing point A
WP B	Weighing point B
WP C	Weighing point C
WP D	Weighing point D
Max	Maximum capacity (weighing range)
Min	Minimum weight

Symbols/mass unit	Description
	Only if W&M is selected: Border around inadmissible decimal place.
t, kg, g, mg, lb, oz	These mass units are available.

Status icons in the info line

Icon	Description
	Remote control via VNC (Virtual Network Computing) is active.
	<ul style="list-style-type: none"> - The clock battery is empty. - The standby battery is empty.
	The standby battery is too hot and is not charging. If this does not go away, the ambient temperature must be checked, see PR 5900 installation manual under [Technical data] - [Environmental influences] - [Ambient conditions] .
	<ul style="list-style-type: none"> - An unsupported USB device is connected. - The maximum current of $i_{max} = 200 \text{ mA}$ has been exceeded.
	Check newly connected devices.
	USB stick was recognized and is operational.
	Stick is in use and may not be removed.
	Conflict in the network settings of the IP address.
	Interface (CX1) was detected. However, there is no connection to the operator terminal.

2.1.2.2 LED status display

Operating status	Color	LED status	Description
Normal operation		Off	
System ready (standby)	Red	Continuous illumination	The display (screen) is switched off.
Power interruption <5 seconds	Red	Slow flashing	After 5 seconds, the device returns to normal operation.
Power interruption >5 seconds	Red	Fast flashing	The device is running a data backup. Once power is restored, the device returns to normal operation (LED off).

Operating status	Color	LED status	Description
After the data backup, there is still a power interruption.		Off	The device switches off.
Power is restored		Off	The device initiates a warm start, see Chapter 2.2.2 .





2.1.3 Operating elements

- Operation using the front-panel keys, see Chapter [2.1.3.1](#)
- Operation using the soft keys, see Chapter [2.1.3.2](#)
- Operation using the navigation keys, see Chapter [2.1.3.3](#)
- Operation using the PC keys, see Chapter [2.1.3.4](#)
- Operation using the VNC program, see Chapter [2.1.4](#)

2.1.3.1 Operation using the front-panel keys

The following table shows the basic meanings of the symbols on the front-panel keys. Depending on the applications, the keys may also have other meanings.

Indicator keys

Key	Description
	Set tare The current gross weight is stored in the tare memory, provided that <ul style="list-style-type: none"> - the weight value is stable. - the device is not in error status. (Function is dependent on configuration)
	Sets gross weight to zero, provided that <ul style="list-style-type: none"> - the weight value is stable. - weight is within zero setting range. (Function is dependent on configuration)
	Display gross/tare weight Pressing the key switches to the next weight (only with tared scale). During calibration, pressing this key displays the weight for 5 seconds with 10x resolution.
	Switching of display between the weighing points: <ul style="list-style-type: none"> - WP-A - WP-B - WP-C - WP-D

Application keys

Key	Description
	Starts an application-specific printout.

Navigation keys



Key	Description
▲	Scroll up in the menu.
▼	Scroll down in the menu.
◀	<ul style="list-style-type: none"> - Cursor to the left - Selection - Exit menu window.
▶	<ul style="list-style-type: none"> - Cursor to the right - Selection - Confirm input/selection.

Menu keys

Key	Description
OK	Confirm input/selection.
EXIT	<ul style="list-style-type: none"> - Cancel entry/selection (after a confirmation prompt) without saving the change. - Exit parameters/menu window.
C	Pressing the delete key deletes individual characters (within an entry) or whole strings of characters.
Soft key 1 to 5	Select appropriate menu function, see also Chapter 2.1.3.2 .
MENU	Switch to the operating menu.

Function keys

Key	Description
F1	Assigned to a defined function (see system menu [System setup] - [Operating parameters]).
F2	Assigned to a defined function (see system menu [System setup] - [Operating parameters]).
?	Displays the relevant help window.

Key	Description
	<ul style="list-style-type: none">- Turns off the display.- Ignores all key presses.- LED is red. <p>Pressing again will switch the display on again.</p>
	Starts an application-specific function.
	Stops an application-specific function.



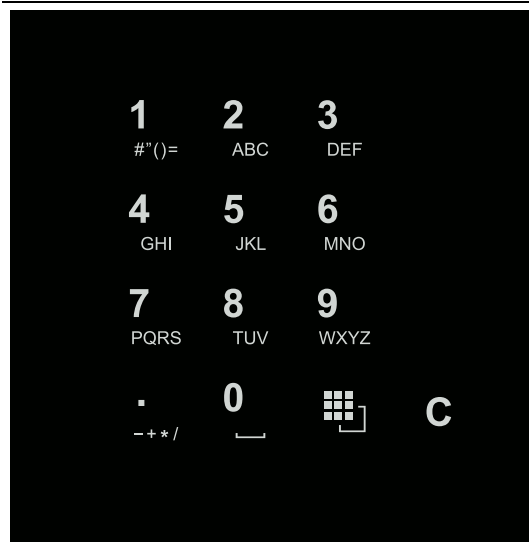

Alphanumeric keypad



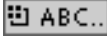

Toggle key

Pressing switches between the following functions:

-  ABC..
Uppercase letters
-  abc..
Lowercase letters
-  IME..
Pinyin
When Chinese has been selected or set under [Operating parameters] - [Input method].
- Hepburn
When Japanese has been selected or set under [Operating parameters] - [Input method].
-  123..
Numbers
-  unit
Units
Select the unit using the cursor keys ▲/▼ and confirm using the key **OK**.

Note:

It is also possible to select a unit by double-clicking on the shift key.



Input without the character table

Pressing once displays the corresponding first character, e.g., "A", at the cursor position. After pressing twice, "B" is displayed at the cursor position and after pressing three times, "C" is displayed.

Press the cursor keys ▼/▲ to finish entering a character or wait approx. 2 seconds.

If only numeric values are required for input, letters are not enabled.

Press the cursor key ◀ within an entry to return to the previous character.

Press the cursor key ▶ within an entry to select the next character.

Within an entry, pressing the delete key **C** deletes the character to the left of the cursor.

Outside of an input, pressing the delete key **C** deletes the whole string of characters.



Input with the character table

Double-clicking on the key displays the character table. Only characters authorized for this input are displayed.

Note:

Only possible when entering text, not when entering numbers or weights. The switching function is turned off.

Procedure:

- Highlight the desired character with the cursor.
- The selected character is shown magnified in the field at the top right.
- Press the key **OK** to enter the character in the input field.
- Another double-click on the toggle key and other characters can be input as described previously.

Input field

In principle:

If alphanumeric characters are already present in the input field of the selected line, they will be completely overwritten after immediate entry.

If alphanumeric characters are already present in the input field of the selected line, you can press the cursor key ► to select the characters to be overwritten and overwrite them.

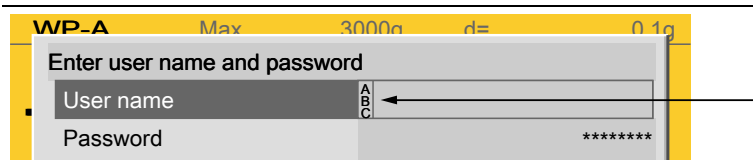

In front of the input field it is indicated whether numeric and/or alphabetic characters can be entered (see arrow).

Switch to the input field using the cursor key ►.

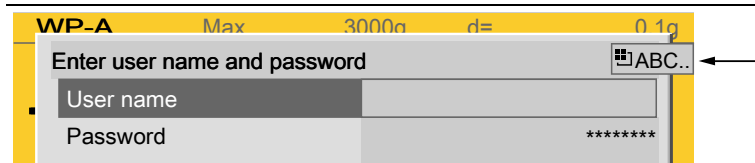

The respective options are displayed (see arrow).

Note:

The character table is turned off.

Keyboard shortcuts



Trigger a cold start, see also Chapter 4.3.

+
EXIT

2.1.3.2 Operation using softkeys

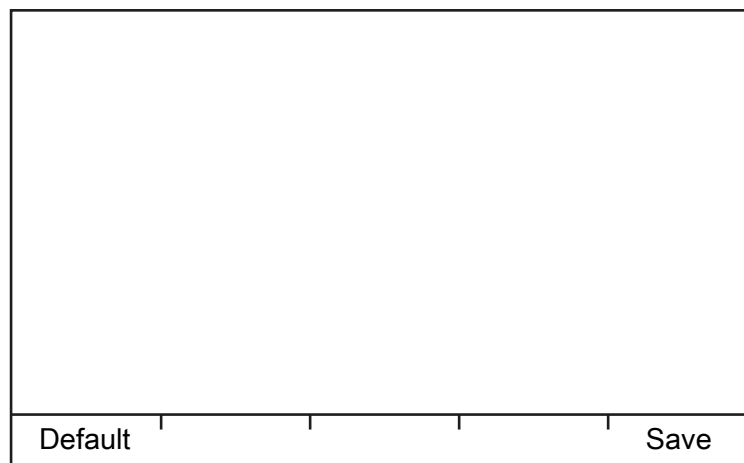

The functions of the five softkeys below the graphic display are indicated in the bottommost text line of the display. Softkey functions shown in gray cannot be selected at the active menu level or with the current access privileges.

In the descriptions of operating sequences which entail the use of softkeys, the softkey function to be selected is shown in square brackets; the softkey symbol is not displayed; example: [Save].

2.1.3.3 Navigation key operation

Menu

The cursor keys, the **OK** and **EXIT** keys are used to navigate through the menus.

Parameters

Use the ▼/▲ cursor keys to select the individual parameters.

Use the **OK** key to confirm the selection.

The required values | texts are entered via the alphanumeric keys.

The **OK** key is used to check the box.



If the list of parameters is long, a vertical bar graph on the left (black and gray) shows which part of the list is displayed.

An existing selection list is indicated by an arrow ► following it.

The parameter is selected using the **OK** key.

2.1.3.4 Operation via PC keys

The device can also be operated using a PC keyboard. The corresponding key assignment is shown in the table below:

PC keyboard	Front keypad
F1	F1
F2	F2
F3	?
F4	MENU
F5...F9	Softkey 1...5
F10	
F11	
F12	
ESC	EXIT
Cursor keys: ↑, ↓, ←, →	▲, ▼, ◀, ▶
Enter key: ↵	OK
Backspace key: ←	C
Numeric keypad	Alphanumeric keypad

2.1.4 Display and operation using VNC client

The display and operating elements are described in the following chapters:

- Overview of front of device, see Chapter [2.1.1](#).
- User interface of TFT screen, see Chapter [2.1.2.1](#).
- Operation using the front-panel keys, see Chapter [2.1.3.1](#).

Setting up the VNC client, see Chapter [2.9.5](#).

2.2 Data security and data storage

The calibration data and parameters of the internal weighing electronics system are saved to the EAROM (Electrically Alterable ROM) on the weighing electronics board. Additional write protection is provided for calibration data and parameters (see Chapter [2.7.2](#)).

The event logger is saved to the SPI flash (Serial Peripheral Interface flash) memory.

The FlashPROM contains:

- BIOS
- Firmware
- Application Program
- Alibi memory
- XML configuration files (for user management, system setup, calibration and application data)

The backups are stored on the SD card (Secure Digital card) (see also PR 5900 installation manual under [Hardware construction]- [Main board]- [SD card slot]).

2.2.1 Power failure

The entire content of the working memory is stored to a NAND flash memory and remains there permanently when the power is interrupted or the device is disconnected from the power.

The SD card and the USB stick are buffered by a battery.

If a HUB (splitter) is inserted into the USB slot and turned off, the connection between the USB stick and battery is broken.

2.2.2 Warm start

When power is restored, all data are reloaded from the NAND flash memory to the working memory and the device is restored to the operating status before the interruption. Filling programs are stopped/started depending on user settings.

2.2.3 Cold start

A cold start is performed if the device finds no saved data with which the last operating state can be restored.

A cold start can have various causes:

- The battery has not been charged properly or is faulty, and it was not possible to save all the data when the power was disconnected.
- The device was restarted using the STOP+EXIT keys, see Chapter [2.2.3.1](#).
- The reset key was pressed, see Chapter [2.2.3.2](#)
- The STOP key was held down during startup and cold start was then selected, see Chapter [3.10](#).

If available, the database from the last backup is restored after a cold start.

2.2.3.1 STOP+EXIT buttons

Pressing STOP+EXIT simultaneously (see Chapter [4.3](#)) initiates a **cold start** of the device:

- The settings are retained.
- The database is initialized.
- The device automatically searches for an existing database on the SD card and asks whether this should be loaded.
- The application must be restarted.

Note:

If [Operating]- [System setup]- [Operating parameters]- [Cold start with STOP+EXIT]- [disabled] is selected in the menu, the device cannot be restarted with STOP+EXIT.

2.2.3.2 Reset key

Briefly pressing (< 1 sec.) the reset key (see PR 5900 installation manual under [Process controller]- [Housing]- [Housing dimensions]- [Control cabinet housing]) initiates a **cold start** of the device:

- The LED flashes once.
- The settings are retained.
- The database is initialized.
- The device automatically searches for an existing database on the SD card and asks whether this should be loaded.
- The application must be restarted.

2.3 Switching on the device

NOTICE

The battery lifetime can be reduced.

- ▶ The device must be switched on regularly - at least every 20 to 30 days.
 - ▶ The device must remain in operation for at least 4 hours after being switched on in order to maintain the battery lifetime.
-

Note:

The following steps must be followed when connecting the device to mains voltage for the first time:

- Set the date and time, see Chapter [4.2](#).
 - Set up the network (only necessary if the device is to be used or configured in the network), see Chapter [4.4](#).
-

The device can be set up as follows:

- Via keys on the front of the device, see Chapter [2.1.3.1](#).
- Via an external PC key, see Chapter [2.1.3.4](#).
- Via a notebook/PC using the VNC software (included on the CD), see Chapter [2.9.5](#).

When the device is powered up, the following appears:

Checking... Booting... Restore...	The device is booting up.
No signal	Error message: if no load cells are connected, see also Chapter 9.1 .
No values from scale	Error message: if there is no communication with the xBPI scale (see also Chapter 9.2). Error message: unable to read weight values from the ADC (analog-digital converter); see also Chapter 9.1 .
Scale not ready	Error message: if no load cells or no scale is connected (see also Chapter 9.1).

The weight display is shown.



2.4 Switching off the device

Switching off the device, see Chapter [6.8](#).

2.5 Device warm-up time

A warm-up time of 30 minutes for the device is required before calibration is started.

2.6 Operating via front-panel keys/PC keyboard

The following options are possible:

- Via keys on the front of the device, see Chapter [2.1.3.1](#).
- Via an external PC keyboard (USB connection), see Chapter [2.1.3.4](#).

2.7 Overwrite protection

2.7.1 CAL switch

Overwrite protection can be activated using the CAL switch to prevent unauthorized access to or overwriting of the calibration data/parameters.

The device can have up to 4 CAL switches. CAL switches 1 and 2 are located on the main board and are accessible via two holes in the housing.

Depending on the model, CAL switches A and B may also be present. They are located on the corresponding weighing electronics board (see PR 5900 installation manual). These switches can only be accessed by removing the device housing.

The exact function of individual switches is listed in the table below.

Note:

In general, we recommend activating the overwrite protection features via the software after calibration to prevent overwriting/data loss (see Chapter 2.7.2).

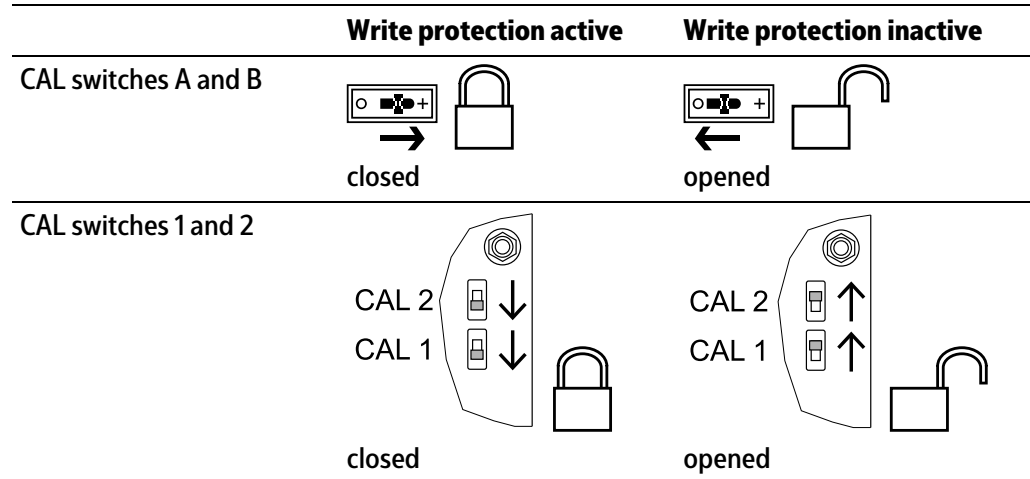

CAL switch	Meaning of "Write Protection Active"
A	Prevents the calibration data/parameters of weighing electronics A from being changed
B	Prevents the calibration data/parameters of weighing electronics B from being changed
1	The following changes are prevented: <ul style="list-style-type: none"> - Allocation of weighing electronics to logical weighing points - Calibration data and parameters of other weighing points - Alibi settings
2	The following is prevented: <ul style="list-style-type: none"> - Loading/flashing of firmware and BIOS to the device, see also Chapter 6.9 - Changing of license settings This CAL switch is sealed for use in legal metrology.

Note:

Changing means:

Changing by entering data into the input fields as well as changing via the functions [Restore] (see Chapter 6.2) and [Import] (see Chapter 6.4).

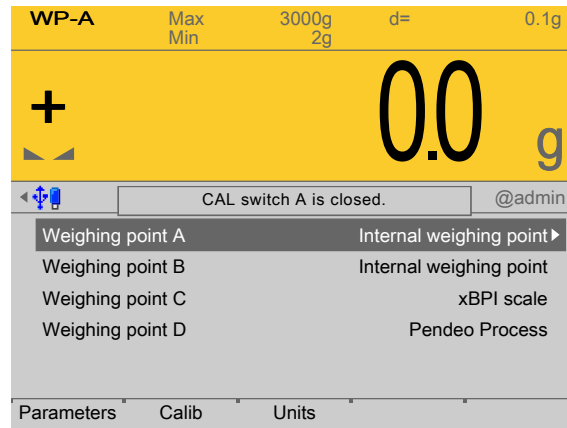

When a CAL switch is closed, a tool tip is displayed in the menu [Weighing points]. The data under the soft keys [Parameters], [Calibration], and [Units] is displayed only.

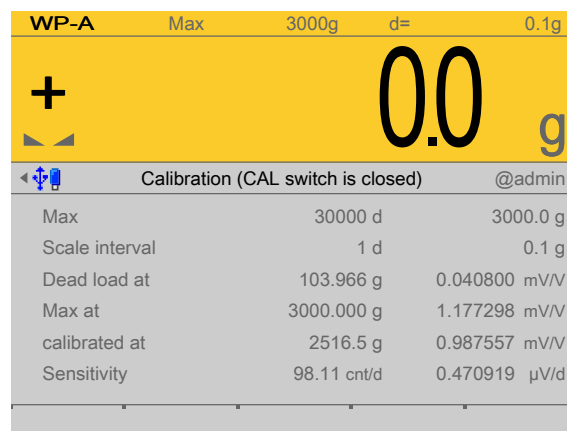

Example of calibration data.

2.7.2 Software

Overwrite protection can be activated via software to prevent unauthorized access to or overwriting of the calibration data/parameters.

Note:

A unique check number is created every time a calibration or changed parameters are saved. This can be viewed in the menu [Operating] - [System information] - [Show calibration check numbers] (see Chapter 5.7) and may also be written on the W&M label.

Accessible via **MENU** – [Operating] - [System setup] - [Weighing points] - [Weighing point x] - [Parameters] - [Settings locked].

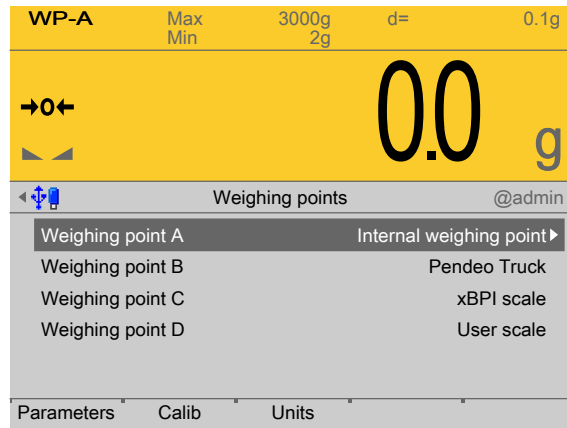

Each weighing point has a [Settings locked] parameter in the menu item [Parameters].

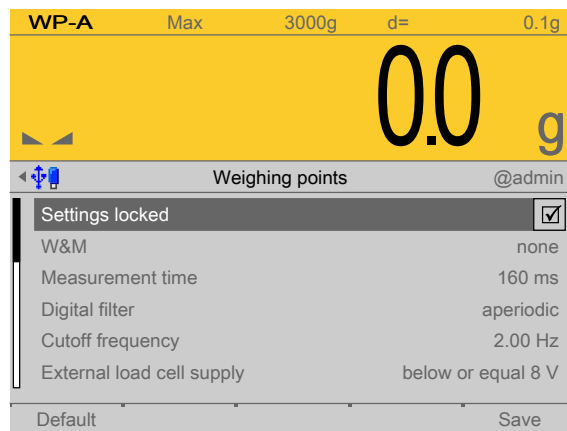

If this parameter is set for the weighing point,

- the calibration data and parameters of the corresponding weighing point and the weighing point allocation are only viewed as if the corresponding CAL switch were closed.
- Only the [Settings locked] parameter can be changed.
- [Restoring]/[Importing] a weighing point is disabled.

Note:

If [Settings locked] and [W&M] have been selected for at least one weighing point, this has the same effect as a closed CAL 1 and CAL 2 switch, see Chapter [2.7.1](#).

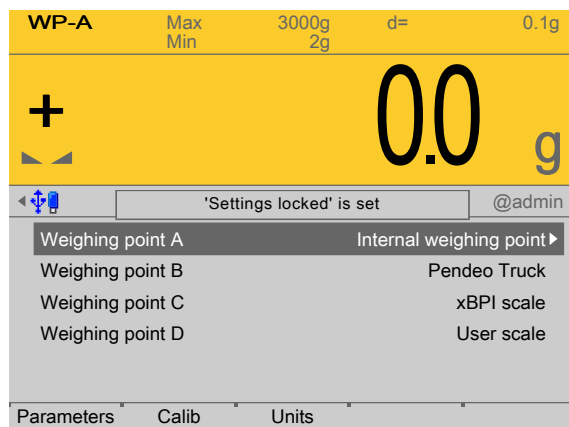

If [Settings locked] is active, a tool tip appears in the menu [Weighing points].
The data under the soft keys [Parameters], [Calibration], and [Units] is displayed only.

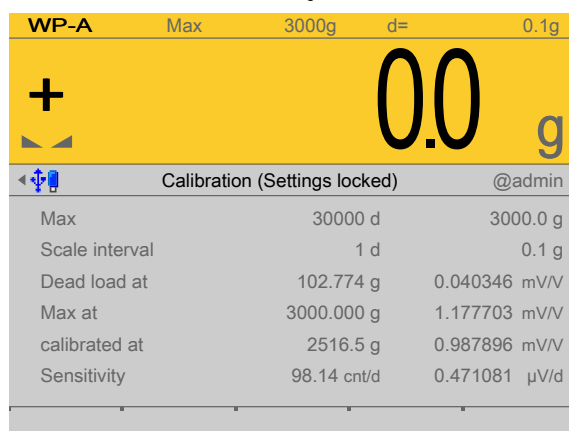

Example of calibration data.

2.8 Switching on blackbox device

2.8.1 Connecting to remote terminal PR 5900/6x, ../7x

The blackbox device can be operated with the PR 5900/6x, ../7x remote terminal.
There are no setting options for the connection to the remote terminal.
If the installation has been carried out correctly, the connection to the remote terminal is automatically established.

Note:

For information on installation and switching on the remote terminal, see PR 5900/6x, ../7x instrument manual.

2.8.2 Network settings

The device has the following factory settings:

- Device IP address (default): 192.168.1.2
- Subnet mask (default): 255.255.255.0

2.8.3 Connecting to notebook/PC

1. Do **not** establish a connection between the blackbox device and the network to begin with!
2. Note down the notebook/PC network settings.
3. Disconnect the notebook/PC from the network.

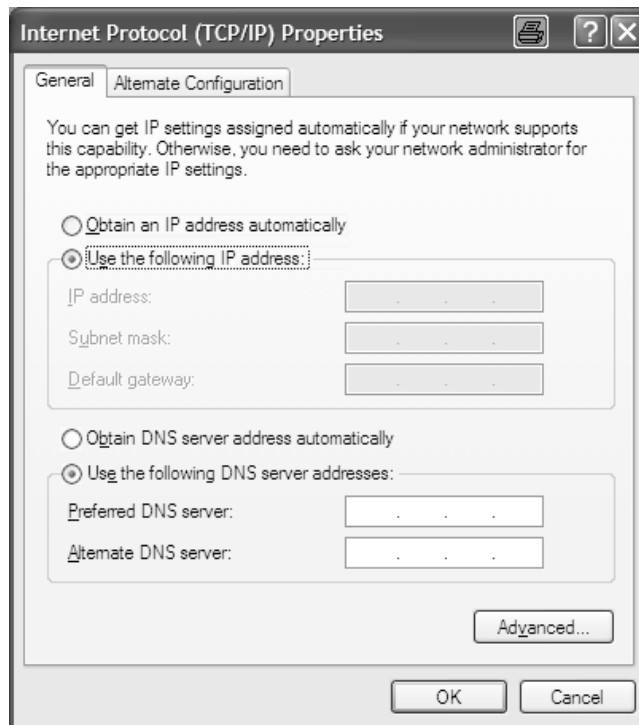

4. In the notebook/PC, click the second line [Use the following IP address] (DHCP is now deactivated).
5. Enter the fixed IP address "192.168.1.2" and the subnet mask "255.255.255.0" and save.
6. Directly connect the notebook/PC and blackbox device with a network cable (without a splitter).
7. Open a web (Internet) browser (e.g. Microsoft Internet Explorer, Mozilla Firefox, etc.).
8. Enter the IP address of the blackbox device: **192.168.1.2**, see Chapter [2.9.5](#).
9. Confirm the entry.
 - ▷ The device name entered under [Host name] appears under the header in brackets.
10. Note down the host name (here: "PR5900-27FF07").
11. In the menu [Operating]- [System setup]- [Network parameters] modify the network address of the blackbox device to the required address or activate DHCP according to the responsible system administrator's instructions; see also Chapter [4.4](#).
12. Save the settings.
 - ▷ The blackbox device sets itself to the new address.

This means that the connection to the notebook/PC is lost.
13. Disconnect the cable connection between the notebook/PC and blackbox device.
14. Connect the blackbox device to the network using a network cable.

15. Re-enter the network settings (as noted previously) on the notebook/PC.
 - ▷ The blackbox device will now be available on the network under the new address and ready for operation.

Note:

Resetting the network settings (see also Chapter 2.8.2) by:

- Holding down the reset button for > 5 s, see Chapter 2.9.4.
 - Selecting and confirming the menu [Operating]- [System setup]- [Network parameters]- [Default] .
-

2.9 Operating via a notebook/PC

The following options are possible:

- Via VNC Viewer (on the enclosed CD-ROM), see Chapter 2.9.5.
- Via the internet browser, see Chapter 3.9.

2.9.1 Finding and connecting the device automatically in the network

If the DHCP server is active in the network, the connected device (if activated in the menu [Operating] - [Default configuration] - [Network parameters] - [use DHCP]) is automatically assigned an IP address.

On the notebook/PC, the host names of the connected devices in the network are listed under [Network].

Double-click the host name to open the device page in the web browser. The IP address is displayed on the bottom right.

2.9.2 Finding and connecting a device with a notebook/PC

If the device is connected to a notebook/PC via a point-to-point connection, an IP address is negotiated via function "AutoIP". This can take up to 2 minutes!

NOTICE

When the IT/DHCP network cable is temporarily connected between the notebook/PC and a device, the DHCP server is lost and the notebook/PC returns to the auto-IP address within approx. two minutes!

- ▶ Reason: The DHCP server/client relationship is checked cyclically at 2...3-minute intervals.
-

1. On the notebook/PC, set the LAN local and Internet Protocol properties to "Obtain an IP address automatically" depending on the operating system.
2. On the device, under MENU - [Default configuration] - [Network parameters] activate the "Use DHCP" parameter (factory/default settings).
 - ▷ The DHCP devices find each other because they fall into an "auto-IP address" in the range 169.254.0.1...169.254.255.254 with the associated auto-subnet mask 255.255.0.0 after a cyclical automatic DHCP server search run due to time overflow (2...3 minutes).

Example:

If the search time is exceeded (because there is "no server found"), the PR 5900 is assigned to an IP address automatically (e.g. 169.254.0.123). The same applies to the notebook or PC (e.g. 169.254.0.54).

These IP addresses are different on both sides:

- equal regarding the first 2 octets of the IP address (e.g. network ID 169.254.)
- different in the last 2 octets of the IP address (e.g. host ID 0.123.)

2.9.3 Searching the device in the network with "IndicatorBrowser"

The IP address can be found out using the "IndicatorBrowser" application (supplied on CD-ROM) and via the "host name" of the device.

The "host name" is composed of the device name and the last 3 bytes of the MAC ID. A label with the complete MAC ID is located on the outside of the device.

MAC: 00:90:6C:6B:6A:5E	
IP: _____	

Host name: PR5900-6B6A5E



For this, the program must be installed and started on a notebook/PC.

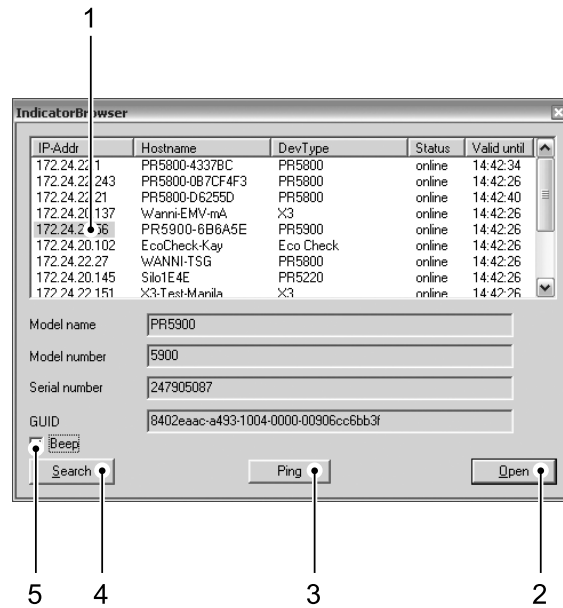

No.	Description
-----	-------------

- | | |
|---|--|
| 1 | The program searches within the current network ID, e.g. 169.254. and 172.24., on all available network adapters in the PC (several possible/recommended, e.g. LAN global/LAN local)
Result:
List of all connected devices with status: search??? – online - byebye – lost??? |
| 2 | Click the button to open the "standard" Internet Browser, e.g. Microsoft Internet Explorer, directly with the marked IP-address. |
| 3 | Click the button to localize the associated device.
Short-term visual feedback from the device:
Regular running light in LED 1, 2, 3. |
| 4 | Click the button to re-start the network search run.
Waiting 2...3 minutes is essential! |
| 5 | Acoustic signal for each device that was detected as "online." |

Note:

If the browser window remains empty after the minimum wait time, or if the expected device is not listed, the network ID of the local notebook/PC must be checked and changed, if necessary.

Only certain Minebea Intec devices are supported by the "indicator browser"!

2.9.4 Resetting the network address

Note:

Holding down (> 5 sec.) the reset key triggers a cold start:

- The settings are not changed.
 - The database is emptied.
 - Current process steps are deleted.
 - The application must be restarted.
 - The database must be restored.
-

Holding down (> 5 sec.) the rest key initiates a reset of the network settings to the factory/default settings.

This means

- "DHCP" is activated.
- "Hostname" is initialized to, e.g. PR 5900-6B6A5E (type MAC-ID).

Example of MAC ID: 00-90-6C-6B-6A-5E

This ensures that a valid address for identification of the device in the network can be assigned to the device from a server, see also Chapter [4.4](#).

Note:

The last 3 bytes of the MAC ID are displayed. A label with the complete MAC ID is located on the outside of the device.

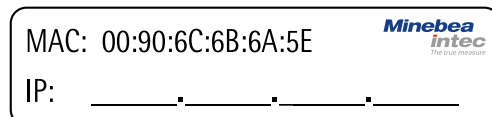

If the device is connected to an IT network (company network) with a DHCP server and if the parameter [use DHCP] is activated in the menu [Operating] - [Default configuration] - [Network parameters] (factory/default settings), no further actions are required except for a waiting time of 2...3 minutes. Subsequently, a network connection is established automatically (device <-> workstation/PC).

2.9.5 Operation using VNC

VNC (on the enclosed CD-ROM) stands for "virtual network computing" and is a program for remote operation of computers.

The program distinguishes between the VNC server and VNC client (viewer). The server program is part of the device software, the client program (viewer) must be run on the notebook/PC in order to operate the device.

Note:

If the colors appear distorted, a better color format must be selected in the VNC viewer.

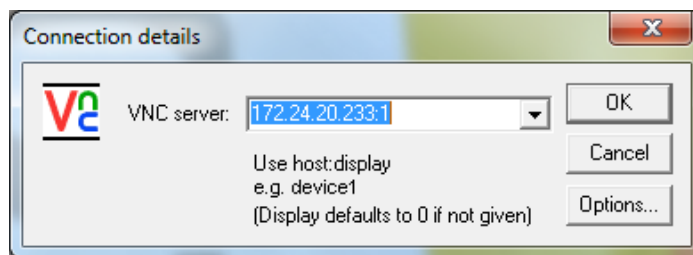

For direct operation using the VNC program, the IP address (extended by :1) must be specified when you run the program, e.g., 172.24.20.233:1.

Note:

In the device, the VNC access to certain notebooks/PCs in the network can be limited, see Chapter 4.4.



The VNC user interface is displayed.

3 Operation and control

3.1 User login/logout

If user management is activated, the user must log in to operate and configure the device:

- User login, see Chapter 3.1.1.
- User logout, see Chapter 3.1.2.

3.1.1 User login

An authorized user must log in to start the application or enter parameters.

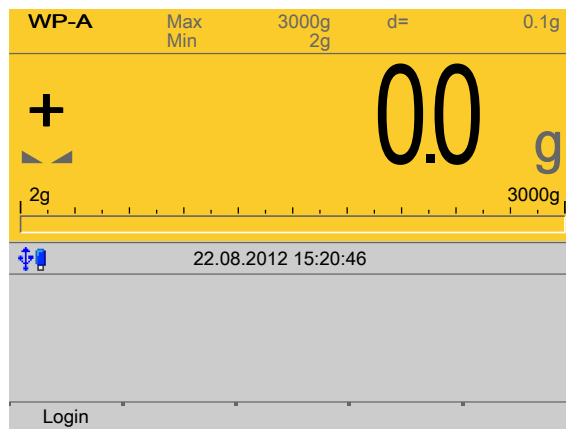

This window only appears if no user is logged in.

1. Press the [Login] soft key to log in as a specific user.

Note:

If the "default" user is active, a password does not need to be entered. The empty entry window only needs to be confirmed to log in.

- ▷ A login window appears.

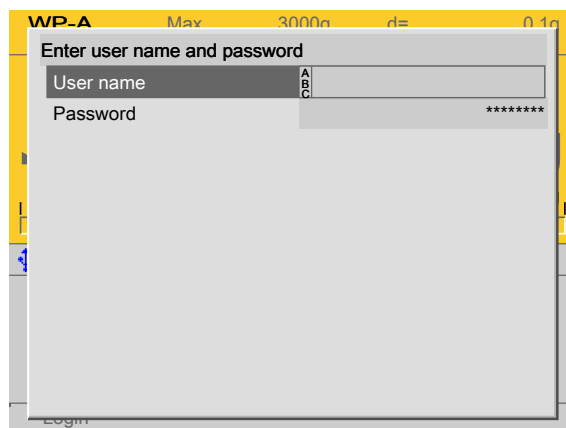

2. Enter and confirm the user name.
3. Enter and confirm the password (access code).

Note:

Default setting: User name: admin; password: admin

▷ The Operating window appears.

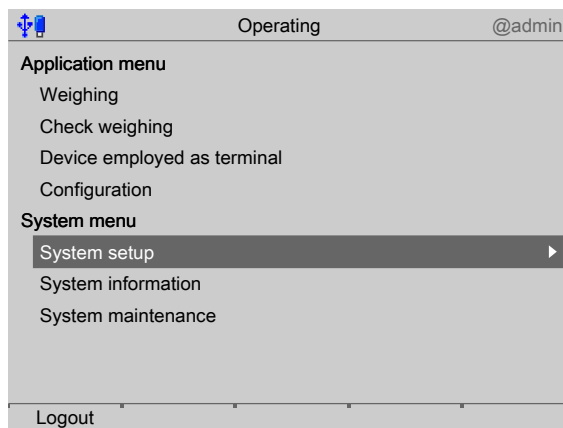

3.1.2 User Logout

In this menu item, the logged-in user is logged out.

Accessible via **MENU** - [Operation]- [Logout] .

1. Press the MENU key to switch to the operating menu.

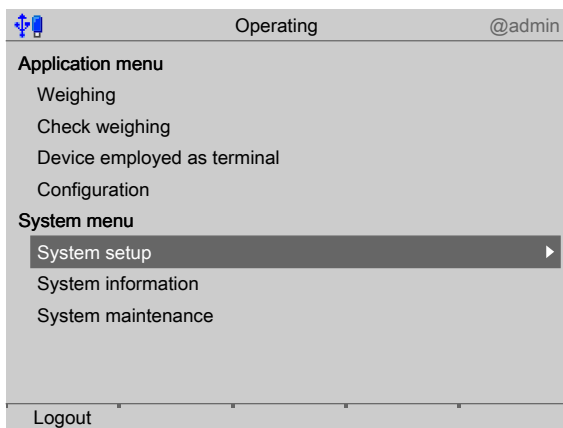

The user who is currently logged in is shown in the top right-hand corner of the display.

2. Press the [Logout] soft key to log out the user who is currently logged in.

If a password is required to log out the user (option activated in the user settings, see Chapter 4.10), the entry window appears accordingly.

3.2 User management

User management is **deactivated** by default, see Chapter 4.10.

By means of user management, access to various menu levels of the device can be limited, if the necessity arises. This includes system setup, system maintenance, access via the website and the various levels of the application (application-specific).

Note:

User management can be activated optionally. However, it is not required for normal operation.

During system installation and set-up, we recommend leaving user management deactivated. This facilitates access to the various menus and to the website.

User management should usually be activated if:

- several people work with the device or have access to it.
- the aim is to prevent unauthorized people from making changes to the device or from influencing the processes controlled by the device.

3.3 Selecting the operating language

Factory settings: system language = operating language (display language)

The operating language can be changed as follows:

- Select and confirm the desired language in the menu [Operating] - [System setup] - [Operating parameters] - [Display language] . Save the change using the [Save] soft key, see also Chapter 4.3.
- Select and confirm in the menu [Operating] - [System setup] - [User management] - [Create/copy/modify user] - [Language] . Save the change using the [Save] soft key, see also Chapter 4.10.1.
- With the function keys F1 and F2, if a key has been assigned to [Change language] in the menu [Operating] - [System setup] - [Operating parameters] - [F1/F2 key] , see Chapter 4.3. The operating language can be changed from any menu.

Note:

When user management is activated, the operating language only changes once the currently logged-in user logs out. It is only possible to switch languages immediately using the F1 or F2 key.

3.4 System menu

Under **System menu** in the **Operating menu**, the process controller is set up, information is accessed and the system is managed.

Note:

The menu items under **Application menu** depend on the application in question and are described in a separate operating manual.

Accessible via **MENU** key - [Operating].

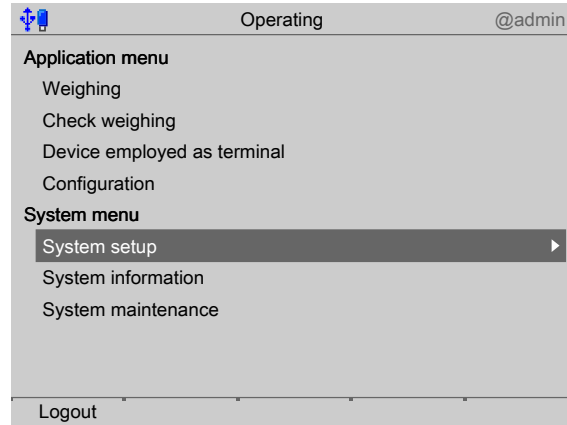

System menu:

- **[System setup]**, see Chapter 4.
 - All parameters relating to weighing electronics can be found under [Weighing points].
 - [Connected devices], see Chapter 4.1.
 - [Date and time], see Chapter 4.2.
 - [Operating parameters], see Chapter 4.3.
 - [Network parameters], see Chapter 4.4.
 - [Network share connections], see Chapter 4.5.
 - [Fieldbus parameters], see Chapter 4.6.
 - [Weighing points], see Chapter 4.7.
 - [Display settings], see Chapter 4.8.
 - [License settings], see Chapter 4.9.
 - [User management], see Chapter 4.10.
 - [Alibi memory], see Chapter 4.11.
- **[System information]**, see Chapter 5.
 - [Show version], see Chapter 5.1.
 - [Show status], see Chapter 5.2.
 - [Show alarm information], see Chapter 5.3.
 - [Show HW options] (hardware options), see Chapter 5.4.
 - [Show ModBus-TCP I/O module], see Chapter 5.5.
 - [Browse the Alibi memory], see Chapter 5.6.
 - [Show calibration check number], see Chapter 5.7.
 - [Show Pendeo data], see Chapter 5.8.
 - [Show event log], see Chapter 5.9.
 - [Print configuration settings], see Chapter 5.10.

- **[System maintenance]**, see Chapter [6](#).
 - [Backup], see Chapter [6.1](#).
 - [Restore], see Chapter [6.2](#).
 - [Export], see Chapter [6.3](#).
 - [Import], see Chapter [6.4](#).
 - [Alibi memory maintenance], see Chapter [6.5](#).
 - [SD card maintenance], see Chapter [6.6](#).
 - [Create service report], see Chapter [6.7](#).
 - [Shutdown & Power off] (switch off device), see Chapter [6.8](#).
 - [Update software], see Chapter [6.9](#).
 - [Factory reset], see Chapter [6.10](#).
 - [Test hardware], see Chapter [6.11](#).

3.5 Help functions

The help function can be accessed from any parameter window using the **?** key. A window appears in which you can scroll up and down through the content using the cursor keys (**↑**, **↓**, **▲**, **▼**). The window can be closed using the **EXIT** key.

Note:

The help text is given in English as a default if the corresponding language is unavailable.

3.6 Alibi memory

The individual functions of the Alibi memory are described in the following menu items:

- In the **System setup** menu, the conditions for a full Alibi memory are configured (menu [Operating]- [System setup]- [Alibi memory]), see Chapter [4.11](#).
 - [Tidy up records], see Chapter [4.11.1](#).
 - [Delete] (complete Alibi memory), see Chapter [4.11.2](#).
- The Alibi memory is searched in the **System information** menu (menu [Operating]- [System information]- [Browse Alibi memory]), see Chapter [5.6](#).
 - [Search for specific date in Alibi memory], see Chapter [5.6.1](#).
 - [Search for a given sequence number], see Chapter [5.6.2](#).
 - [Status Alibi memory], show status, see Chapter [5.6.3](#).
- In the **System maintenance** menu the records of the Alibi memory are exported or printed and deleted if necessary ([Operating]- [System maintenance]- [Alibi memory maintenance]), see Chapter [6.5](#).
 - [Export selection of records], the Alibi memory is exported to a storage medium in XML format, see Chapter [6.5.1](#).
 - [Export + tidy up selection of records], the Alibi memory is exported to a storage medium in XML format and then deleted from the device, see Chapter [6.5.2](#).

- [Print selection of records], the Alibi memory is printed, see Chapter 6.5.3.
- [Print + tidy up selection of records], the Alibi memory is printed and then deleted from the device, see Chapter 6.5.4.

3.7 Showing the calibration data

The calibration data is displayed in the format entered/determined during calibration. Accessible via **MENU** – [Operating] - [System setup] - [Weighing points] - [Weighing point x] - [Calib].

WP-A	Max	3000g	d=	0.1g
+ 0.0 g				
Calibration @admin				
Max		30000 d		3000.0 g
Scale interval		1 d		0.1 g
Dead load at		102.832 g		0.040368 mV/V
Max at		3000.000 g		1.177688 mV/V
calibrated at		2516.5 g		0.987884 mV/V
Sensitivity		98.14 cnt/d		0.471075 μ V/d
New Modify				

The calibration data is displayed:

- Scale interval and maximum capacity (Max)
- Scale interval(s)
- Dead load in weight and mV/V
- Weight and mV/V for maximum capacity
- Calibration weight* and corresponding mV/V
- Number of internal counts and voltage per scale interval

* After input with mV/V, the maximum capacity and the mV/V value entered are displayed.

3.8 Increased resolution (10-fold) of the weight value

In the menu [Operating]- [System setup]- [Weighing points]- [Weighing point x] , the weight is displayed with increased resolution (10-fold) for five seconds after a weighing point is selected, using the following keys:

- Key 
- Function key F1 and/or F2 (if the function key has been assigned in the menu [Operating]- [System setup]- [Operating parameters]- [F1/F2 key]).

If the parameter [W&M] is selected for the weighing point, the weight value is marked as an invalid weight with the \triangle symbol. After 2...3 seconds the display returns to normal resolution.

3.9 Functions via the website

If the device is connected to the network, it can be displayed e.g. in the "Windows" operating system under [Network].

- ▶ Double-click on the corresponding device symbol in the window.
 - ▷ The web menu is opened in the available Internet browser (in English only).

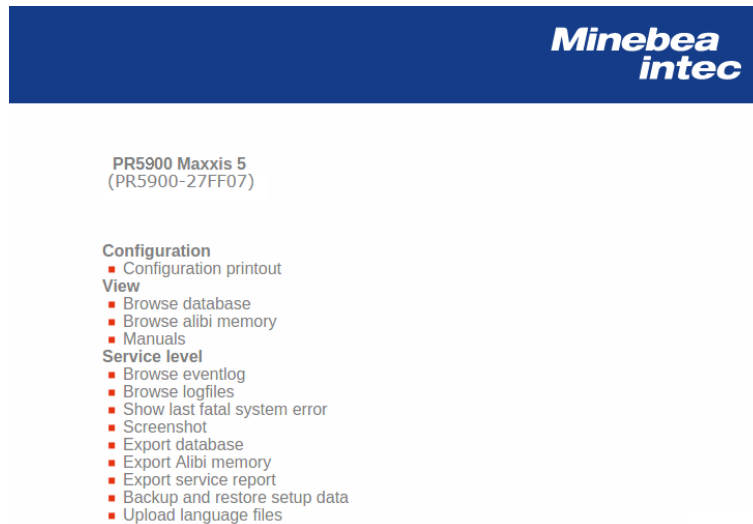

The device name entered appears in brackets below the header (in the menu [Operating] - [System setup] - [Network parameters] - [Host name]), see Chapter [4.4](#).

Configuration:

[Configuration printout]

Can be used for printing the configuration data as a text file, see Chapter [10.1](#).

View:

[Browse Database]

Browse the application-specific database, see Chapter [3.9.1](#).

[Browse Alibi memory]

Browse the Alibi memory, see Chapter [3.9.2](#).

[Manuals]

PDF files are saved on the SD card (only SD cards from Minebea Intec supplied with the device), see Chapter [3.9.3](#).

Service level:

Note:

Some functions require additional rights. When user management is activated, the logged in user must have rights for [Use functions on the website] and the appropriate system rights.

[Browse eventlog]

Browse event log, see Chapter [3.9.4](#).

[Browse logfiles]

Browse, display, copy, print log files, see Chapter [3.9.5](#).

[Show last fatal system error]

Display, copy, print the error log, see Chapter [3.9.6](#).

[Screenshot]

Saves a screenshot, see Chapter [3.9.7](#).

[Export database]

Export database as XML file, see Chapter [3.9.8](#).

[Export Alibi memory]

Export Alibi memory as XML file, see Chapter [3.9.2](#).

[Export service report]

Export service report as XML file, see Chapter [3.9.10](#).

[Backup and restore setup data]

Create backup of setup data and restore setup data, see Chapter [3.9.11.2](#).

[Upload language files]

Uploads the language files to the device, see Chapter [3.9.12](#).

3.9.1 Browse database

In this web menu item, an application-specific database is searched.

Accessible via the web menu - [Browse Database].

1. Click [Browse Database] in the web menu.
 - ▷ A table with entries appears.
 - Click on the entries in the table to display the corresponding content.
2. Click the  symbol to return to the web menu.

3.9.2 Browsing the Alibi memory

In this web menu item, the Alibi memory is searched via a calendar window.

Accessible via the web menu - [Browse Alibi Memory].

1. Click [Browse Alibi Memory] in the web menu.
 - ▷ A calendar window appears.

MONTH	2012-01	2012-02	2012-03	2012-04	2012-05	2012-06	2012-07	2012-08	2012-09	2012-10	2012-11	2012-12
Day	(17)	(1)	(0)									
	2012-03-29											
	2012-03-24											
	2012-03-25											
	2012-03-26											
	2012-03-27											
	2012-03-28											
	2012-03-29 (0)											
	2012-03-30											
	2012-03-31											

Past months are underlined. The current day is displayed in bold in the "Day" row and column.

The number of saves is given in parentheses ().

2. Click on the desired date.

MONTH	<u>2012-01</u>	2012-02	2012-03	2012-04	2012-05	2012-06	2012-07	2012-08	2012-09	2012-10	2012-11	2012-12
	(17)	(1)										
Day	2012-02-14											
2012-02-01	No.18 : 2012-02-14-15:25:01 SN:390050332											
2012-02-02	*Please enter*											
2012-02-03												
2012-02-04	1:G :A <9709 kg>											
2012-02-05	2:NET :A <9709 kg>											
2012-02-06	3:T :A 0 kg											
2012-02-07												
2012-02-08												
2012-02-09												
2012-02-10												
2012-02-11												
2012-02-12												
2012-02-13												
2012-02-14	(1)											
2012-02-15												

A table is displayed for each save.

3. Click the  symbol to return to the web menu.

3.9.3 Displaying manuals

In this web menu item, the saved manuals that are located on the SD card supplied with the device by Minebea Intec are displayed.

Accessible via the web menu - [Manuals].

1. Click [Manuals] in the web menu.
 - ▷ Several files are listed. Click on a file to view its contents.
2. Click the  symbol to return to the web menu.

3.9.4 Browse the event log

In this web menu item, the event log is displayed in the event logger window.

Accessible via the web menu - [Browse Eventlog].

The log is a table showing the individual events on the device. This log can be used to analyze any possible problems.

The three event types are:

- Error
- Info
- Warning

The four source types are:

- [Fatal error]
- [Setup]
- [Power system]
- [Indicator]

1. Click [Browse Eventlog] in the web menu.

▷ The "Eventlogger" window appears.

Eventlogger

To refresh the event view press Refresh reading the events. If you do not want to show all events press Stop reading the events. There are 3 different types of events (Error, Info, Warning) and 4 different sources (Fatalerror, Setup, Powersystem, Indicator).

Refresh reading the events

Stop reading the events

Show entries Search:

Title	Type	From	Date	Description
Event	Info	Setup	2012-03-29 11:13:27	user=Admin logged in
Event	Info	Setup	2012-03-29 11:13:27	user=Admin logged in
Event	Info	Setup	2012-03-29 10:13:10	user=Admin logged out
Power event	Info	Powersystem	2012-03-29 09:41:15	device has switched on
Event	Info	Setup	2012-03-29 08:04:09	user=Admin logged in
Event	Info	Setup	2012-03-29 08:04:09	user=Admin logged in
Event	Info	Setup	2012-03-28 16:24:38	user=Admin logged out
Event	Error	Fatalerror	2012-03-28 15:29:15	watchdog reset
Event	Info	Setup	2012-03-28 09:36:43	user=Admin logged in
Event	Info	Setup	2012-03-28 09:36:42	user=Admin logged in

Showing 1 to 10 of 385 entries First Previous 1 2 3 4 5 Next Last

2. Click the  symbol to return to the web menu.

3.9.5 Browse log files

In this web menu item, the log files can be searched, displayed, copied and printed.

Log files can be used to analyze any possible problems.

Accessible via the web menu - [Browse logfiles]

1. Click [Browse logfiles] in the web menu.
 - ▷ Several files are listed. Click on a file to view its contents.
2. Click the  symbol to return to the web menu.

3.9.6 Displaying a log of the last system error

In this web menu item, the log of the last system error can be displayed, copied and printed.

Logs can be used to analyze any possible problems.

Note:

This data is also contained in the service report.

Accessible via the web menu - [Show last fatal system error]

1. Click [Show last fatal system error] in the web menu.
 - ▷ The last saved system error is displayed.

```
#5 2012-03-20 08:24:07
EXCEPTION 5($014): Reserved
PC=C0004102 FRM=4014 SR=2000
D0=02CFA0C0 A0=0000003A SP+00=8000766C
D1=000000CC A1=41FCAF3A SP+04=8000762B
D2=00000002 A2=80000B7C SP+08=000491F0
D3=00000005 A3=00000000 SP+12=00000005
D4=00000000 A4=00000066 SP+16=00004552
D5=41296500 A5=412C16F4 SP+20=41296500
D6=00000000 A6=800076F0 SP+24=80000EF6
D7=00000000 A7=800075AC SP+28=8000766C
C00040F2:202F0010 MOVE.L $0010(A7),D0
C00040F6:25400020 MOVE.L D0,$0020(A2)
C00040FA:4C010800 MULS.L D1,D0
C00040FE:206A0028 MOVEA.L $0028(A2),A0
C0004102>4C6A0000001C DIVU.L $001C(A2),D0
C0004108:2400 MOVE.L D0,D2
C000410A:06820000003A ADDI.L #0000003A,D2
```

2. Click the  symbol to return to the web menu.

3.9.7 Screenshot

In this web menu item, the device screenshot is displayed and can be saved if required.
Accessible via the web menu - [Screenshot].

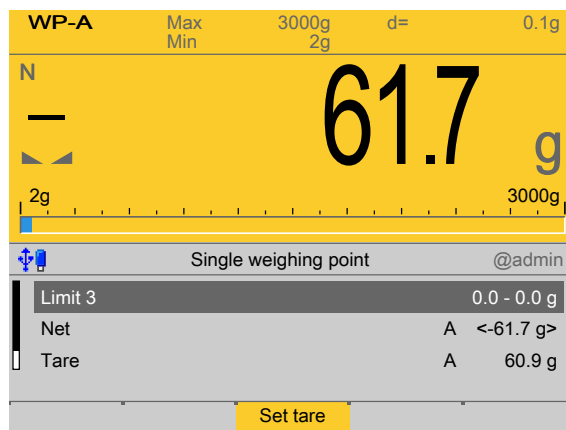

1. Configure the corresponding display (here: Weighing) on the device.
2. Click [Screenshot] in the web menu.
3. The device display is shown on the notebook/screen.
4. Right-click on the display and save to the desired folder via the [Save image as...] option.
5. Click the  symbol to return to the web menu.

3.9.8 Export database

In this web menu item, the export of a database is saved in a selected directory as an XML file.

Accessible via the web menu - [Export database].

1. Click [Export database] in the web menu.
 - ▷ If applicable, an input window appears.
2. If applicable, enter user name and password and confirm.

- ▷ The file download window of the Internet browser appears.
- 3. Click [Save].
- 4. Select a directory in which to save the XML file.
- 5. Click [Save].

3.9.9 Export Alibi memory

In this web menu item, the export of the Alibi memory is saved in a selected directory as an XML file.

Accessible via the web menu - [Export Alibi memory].

Example: "InternetExplorer"

1. Click [Export Alibi memory] in the web menu.
 - ▷ If applicable, an input window appears.
2. If applicable, enter user name and password and confirm.
 - ▷ A page appears on which the Alibi entries to be exported can be selected.

Select alibi records to export. First record is #1. Last record is #51.

First sequencenumber (1...51)

Last sequencenumber (1...51)

3. Enter the desired range of records (here: 1...51) and click [Start export].
 - ▷ The file download window of the Internet browser appears.
4. Click [Save].
5. Select a directory in which to save the XML file.
6. Click [Save].
7. Click the  symbol to return to the web menu.

3.9.10 Export service report

In this web menu item, the export of the service report is saved in a selected directory as an XML file. In the event of an error, the file can be sent to customer service.

Accessible via the web menu - [Export service report].

Example: "InternetExplorer"

1. Click [Export service report] in the web menu.
 - ▷ If applicable, an input window appears.
2. If applicable, enter user name and password and confirm.
 - ▷ The file download window of the Internet browser appears.
3. Click [Save].
4. Select a directory in which to save the XML file.
5. Click [Save].
6. Click the  symbol to return to the web menu.

3.9.11 Backup and restore setup data

In this web menu item,

- [Backup] can be used to save the setup, user, calibration and application data as a backup on the PC, see Chapter [3.9.11.1](#).
- [Restore] can be used to restore the setup, user, calibration and application data on the device, see Chapter [3.9.11.2](#).

Note:

This function **cannot** be used to back up the database on the PC and restore it on the device. This is only possible in the menu [Operating] - [System maintenance] .

Accessible via the web menu - [Backup and restore setup data].

1. Click [Backup and restore setup data] in the web menu.
 - ▷ If applicable, an input window appears.
2. If applicable, enter user name and password and confirm.
 - ▷ The backup and restore menu appears.

3.9.11.1 Backup

In this web menu item, a backup with the setup, user, calibration and application data is created on the PC.

Accessible via the web menu – [Backup and restore setup data] - [Backup].

PR5900 Maxxis 5
(PR5900-27FF07)

Backup

Press to copy all configuration data from "PR5900-27FF07" to your local pc

Restore

Select a **.xml**-File

Press to save all configuration data to "PR5900-27FF07"

Backup and restore menu.

1. Click [Backup] to create a backup.
Example: "InternetExplorer"
 - ▷ The file download window of the Internet browser appears.
2. Click [Save].
3. Select a directory in which to save the XML file.
4. Click [Save].

The backup has been saved in the selected directory.

5. Click the  symbol to return to the web menu.

Possible error messages, see Chapter [3.9.11.3](#)

3.9.11.2 Restore

In this web menu item, the setup, user, calibration, and application data is restored on the device.

Accessible via the web menu – [Backup and restore setup data] - [Restore].

PR5900 Maxxis 5
(PR5900-27FF07)

Backup

Press to copy all configuration data from "PR5900-27FF07" to your local pc

Restore

Select a **.xml**-File setup-PR59...123220.xml

Press to save all configuration data to "PR5900-27FF07"

1. Click [Browse] to select an XML file for restoring.
Example: "InternetExplorer"
 - ▷ The file upload window of the Internet browser appears.
2. Select the XML file (e.g. setup-PR5900 27FF07-20130729-082010.xml).
3. Click [Open].
 - ▷ The file name is displayed in the selection window.
4. Click [Restore].
 - ▷ The setup data is saved on the device.
5. Click the  symbol to return to the web menu.

Possible error messages, see Chapter [3.9.11.3](#)

3.9.11.3 Error messages

In the web menu item Backup/Restore, the following error messages may appear when backing up or restoring the setup data:

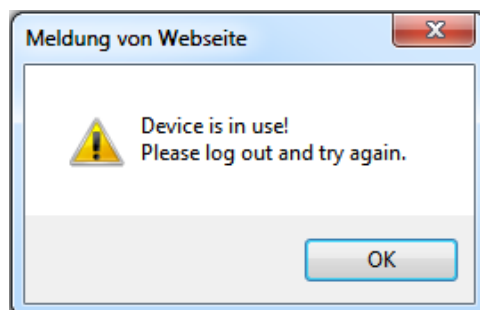

This message appears if the user is not logged out.

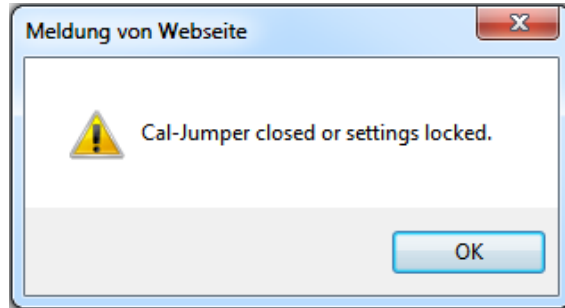

This message appears if a CAL switch is closed and/or if [Operating] - [System setup] - [Weighing points] - [Weighing point x] - [Parameters] - [Settings locked] is active.

3.9.12 Loading language files

In this web menu item, the language files are loaded onto the device.

Note:

This function allows translations to be tested during development. The files **are only available in the working memory** and will be lost when the next cold start occurs.

For **permanent storage**, the language files must be loaded onto the device together with the application in the menu [Operating] - [System maintenance] - [Update software] (see Chapter 6.9).

Accessible via the web menu - [Upload Language Files].

1. Click [Upload Language Files] in the web menu.
 - ▷ A selection window opens.

2. Click [Browse], select the corresponding "mo files," and click [upload] to load the files onto the device.
3. Click the  symbol to return to the web menu.

3.10 BIOS BOOT menu

If the device cannot perform a normal **system start**, the BIOS BOOT menu must be used:

- Open BIOS BOOT menu, see Chapter [3.10.1](#).
- BIOS BOOT menu in blackbox device, see Chapter [3.10.2](#).
- System messages in blackbox device, see Chapter [3.10.3](#).

Note:

The BIOS BOOT menu is in **English**, regardless of the selected language settings.

3.10.1 Open BIOS BOOT menu

The following modes are available for a system start in the BIOS BOOT menu:

- Warm start [Warm start], see Chapter [3.10.1.1](#).
- Cold start [Cold start], see Chapter [3.10.1.2](#).
- Restore [Recover], see Chapter [3.10.1.3](#).

Requirements:

- The supply voltage is disconnected.
- All LEDs have gone out.

If this is not the case, the connection to the standby battery must be interrupted with the power supply disconnected (pull the plug out carefully). Restore the connection afterwards.

Note:

The battery is located beneath the weighing electronics board WP A, see PR 5900 installation manual.

Accessible via **STOP** key.

1. Hold down the **STOP** key.
2. Switch on the supply voltage.
 - ▷ The message "STOP key detected" appears.
3. Release the **STOP** key.
 - ▷ The BIOS BOOT menu appears.

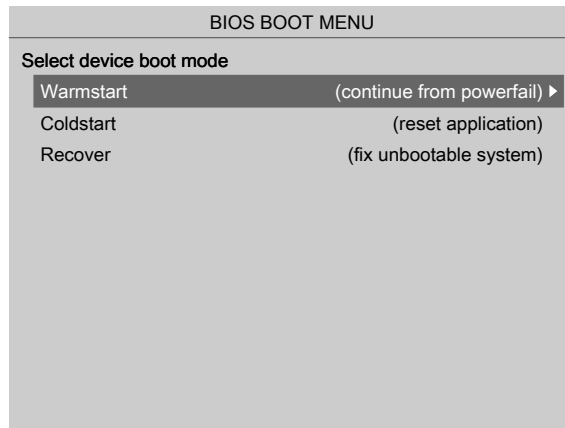

3.10.1.1 Warm start

Perform a system start via the warm start mode in the **BIOS BOOT menu**.
Accessible via **STOP** key - [Warm start].

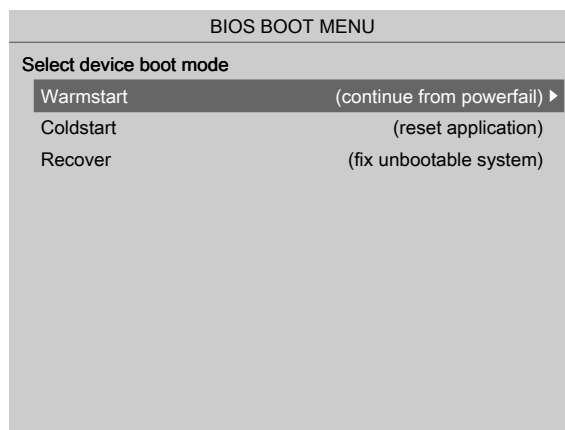

- ▶ Confirm [Warm start] with the ▶ key/**OK**.
- ▷ The device starts up in the same way it does after a power failure.

Note:

This menu item is disabled if a warm start is not possible. A warm start may not be possible for the following reasons:

- Fatal system error
 - Faulty battery
-

3.10.1.2 Cold start

Perform a system start via the cold start mode [Coldstart] in the **BIOS BOOT menu**.
Accessible via **STOP** - [Cold start] key.

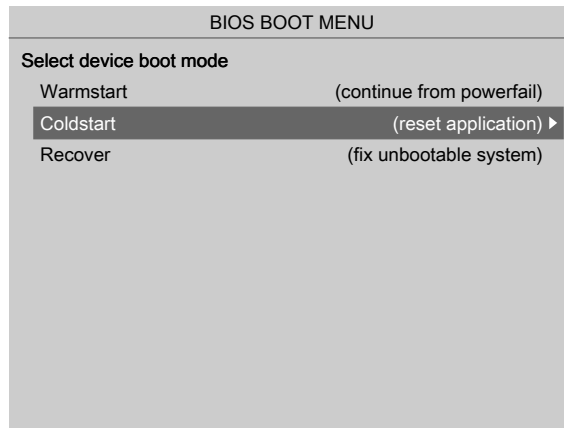

- ▶ Select [Cold start] with the ▼ key and confirm with the ▶ key/**OK**.
 - ▷ The device starts, the database is cleared, and the application restarts.

Note:

If the device starts successfully, an existing database backup, if there is one, can be re-imported (see Chapter [6.2](#)).

3.10.1.3 Restore

Replace or repair a faulty application via the restore mode (Recover) in the **BIOS BOOT menu**:

- For restore from SD card [Restore last Software from SD-Card], see Chapter [3.10.1.3.1](#)
- For load software with FlashIt! [Listen from FlashIt], see Chapter [3.10.1.3.2](#).
- For cold start in safe mode [Cold start in safe mode], see Chapter [3.10.1.3.3](#).

Accessible via **STOP** - [Recover] key.

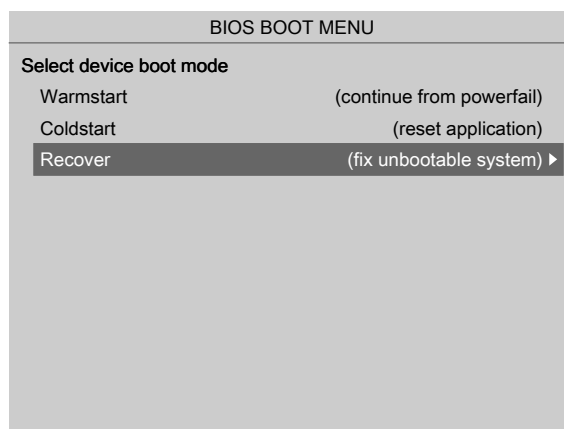

1. Select [Recover] with the ▼ key and confirm with the ▶ key/**OK**.
 - ▷ The overwrite protection statuses are checked (CAL switches and parameters [Settings locked]).

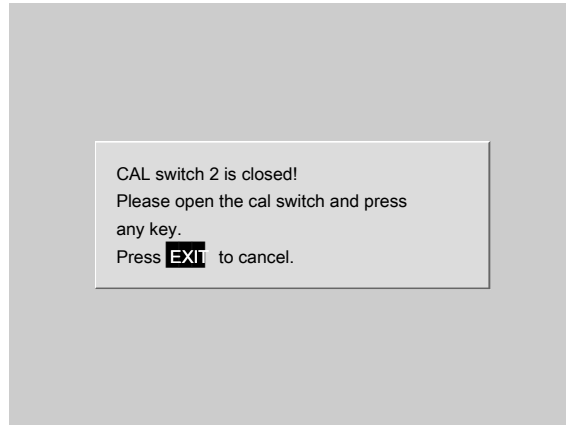

This message appears if at least one CAL switch is closed.

2. Open the CAL switch and press any key to check the statuses again.

Or: Press the **EXIT** key to cancel the process and return to the BIOS menu.

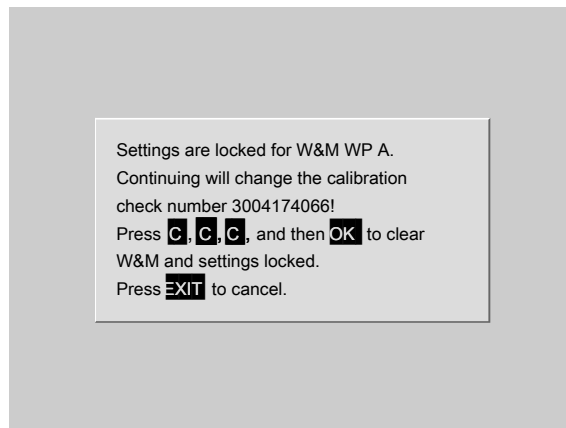

This message appears if the [W&M] parameter has been set to another value besides [none] for at least one weighing point and [Settings locked] has been activated.

3. Press the **C** key three times and then press the **OK** key to reset the [W&M] parameter and [Settings locked].

▷ The calibration check number changes.

Or: Press the **EXIT** key to cancel the process and return to the BIOS BOOT menu.

4. If all checks have been carried out, the troubleshooting menu (ERROR RECOVERY menu) appears.

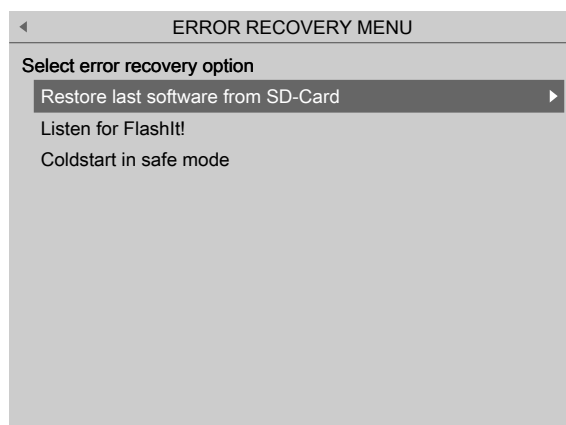

3.10.1.3.1 Restore from SD card

Replace a faulty application in the **BIOS BOOT menu** via restore last software from SD card.

Accessible via the **STOP** key [Recover]- [Restore last Software from SD-Card] .

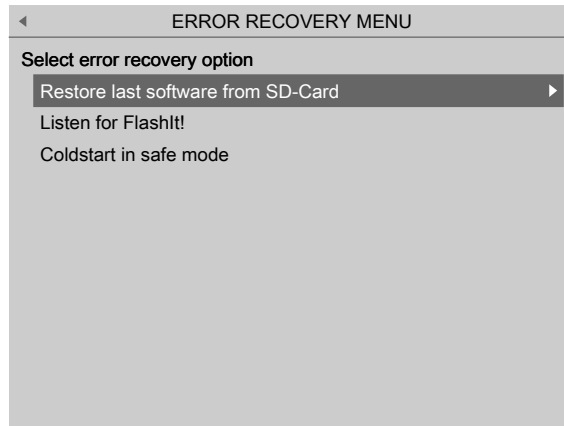

- ▶ Confirm [Restore last Software from SD-Card] using the ▶ key/**OK**.
 - ▷ The last saved software image (BIOS, firmware, and application) is restored in the device.

3.10.1.3.2 Load software with FlashIt!

Load a faulty application via software with FlashIt! in the **BIOS BOOT menu** Replace (Listen from FlashIt).

Accessible via the **STOP** key [Recover]- [Listen from FlashIt] .

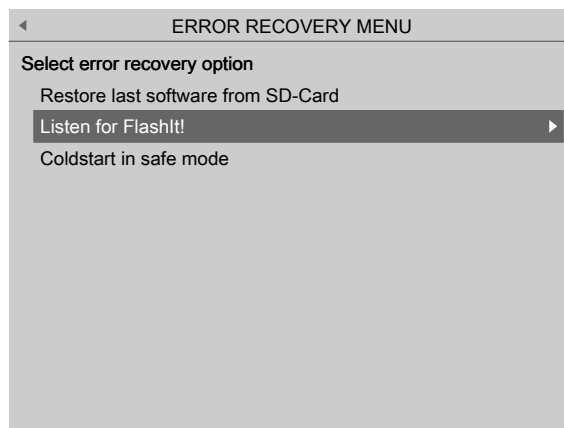

- ▶ Select [Listen from FlashIt] with the ▼ key and confirm with the ▶ key/**OK**.
 - ▷ It is now possible to load software on the device via the network using the "FlashIt!" program, see also Chapter [6.9.3](#).

3.10.1.3.3 Cold start in safe mode

Repair a faulty application using [Coldstart in safe mode] in the **BIOS BOOT menu**.

Examples:

An application was flashed that caused an error or a crash on starting.

Settings have been made that cause errors or crashes.

Accessible via the **STOP** key - [Recover] - [Cold start in safe mode] .

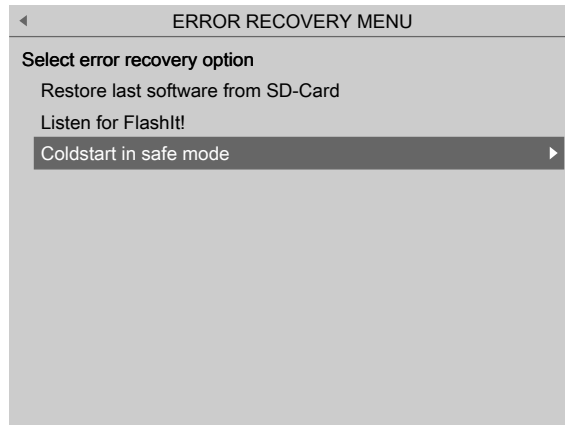

1. Select [Cold start in safe mode] with the ▼ key and confirm with the ► key/**OK**.
The device starts in a mode where all settings (even language settings) are ignored.
▷ A help window appears.

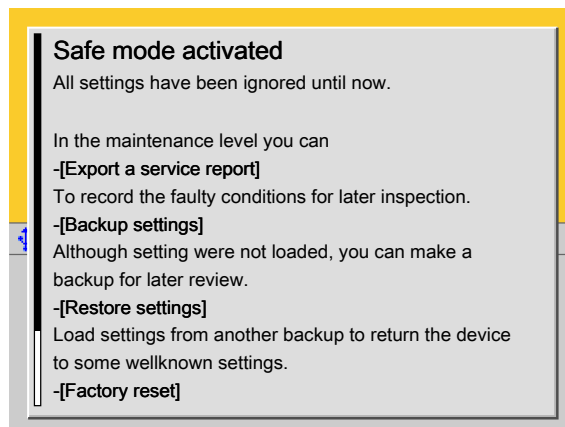

2. Press the **EXIT** key to close the help window and switch to the system maintenance menu (ERROR RECOVERY menu).

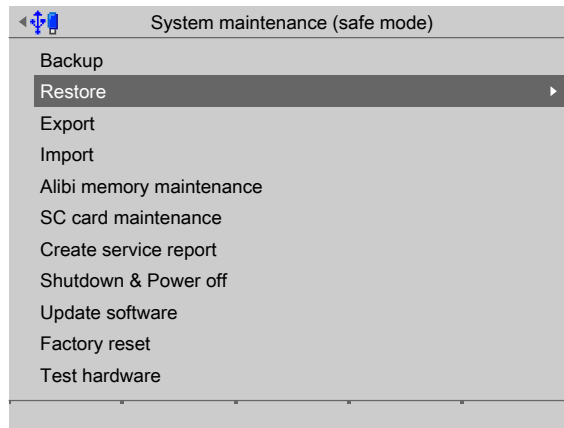

3. Select the desired menu item with the ▼ key and confirm with the ► key/**OK**.
The rest of the procedure is described in Chapter 6.
4. Press the **EXIT** key to exit the system maintenance menu (ERROR RECOVERY menu).
▷ A prompt window appears.

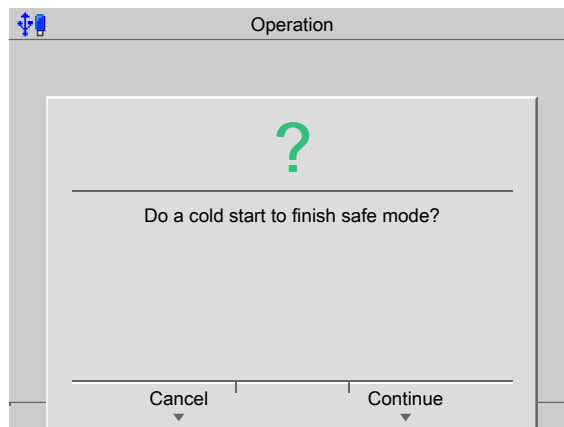

5. Press the [Cancel] soft key to select additional menu items in the system maintenance menu (ERROR RECOVERY menu) if necessary.
6. Press the [Continue] soft key to perform a cold start.

3.10.2 BIOS BOOT menu in blackbox device

Since the BIOS cannot communicate with the remote terminal or VNC client, individual menu items are triggered via the reset key and displayed via LED:

- The BIOS BOOT menu is automatically activated when five restarts fail one after the other.
- The BIOS BOOT menu can be accessed manually if the reset key is held down while the device is being switched on.

If the BIOS BOOT menu is activated, the LED flashes quickly and an acoustic signal sounds repeatedly.

The following menu items can be selected in the BIOS BOOT menu via the reset key:

Menu item	Reset key	LED
Cold start	press once	flashes once 0-----0-----0---
Safe mode	press again	flashes twice 00-----00-----00---
Restore software from SD card	press again	flashes three times 000-----000-----000---

1. Press the reset key repeatedly to select other menu items.
2. Press the "Reset" button for as long as it takes (at least 2 seconds) for the LED to illuminate continuously to confirm the selection.

3.10.3 System messages in blackbox device

The BIOS writes the messages to the temporary memory of the firmware.

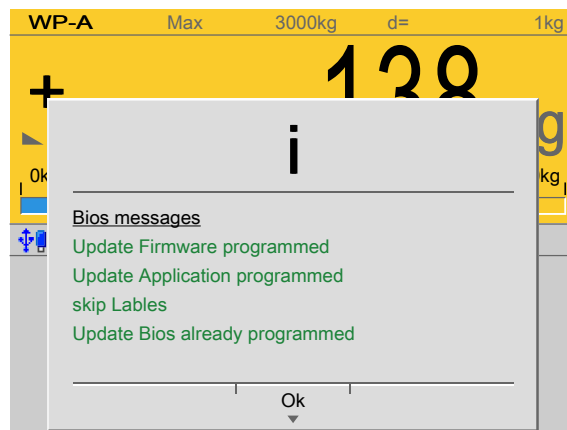

These messages are displayed once the device has booted successfully.

Note:

The BIOS messages are always in **English**, regardless of the selected language settings.

A cold start is carried out if a fatal system error occurs.

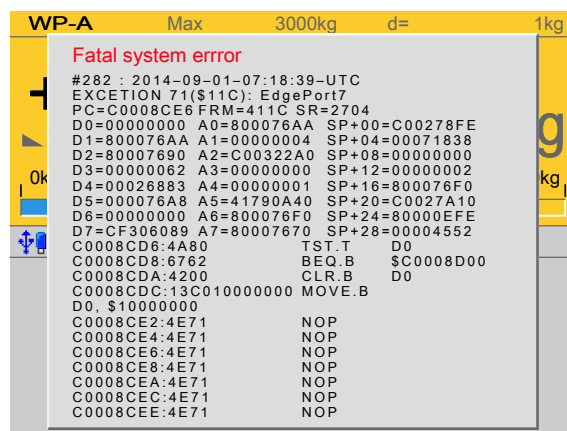

This message appears on the display after the device has booted.

4 System setup

In the system setup menu (under **System menu**), the system is set up and configured.

- [Connected devices], see Chapter 4.1.
- [Date and time], see Chapter 4.2.
- [Operating parameters], see Chapter 4.3.
- [Network parameters], see Chapter 4.4.
- [Network share connections], see Chapter 4.5.
- [Fieldbus parameters], see Chapter 4.6.
- [Weighing points], see Chapter 4.7.
- [Display settings], see Chapter 4.8.
- [License settings], see Chapter 4.9.
- [User management], see Chapter 4.10.
- [Alibi memory], see Chapter 4.11.

Accessible via **MENU** – [Operating] - [System setup].

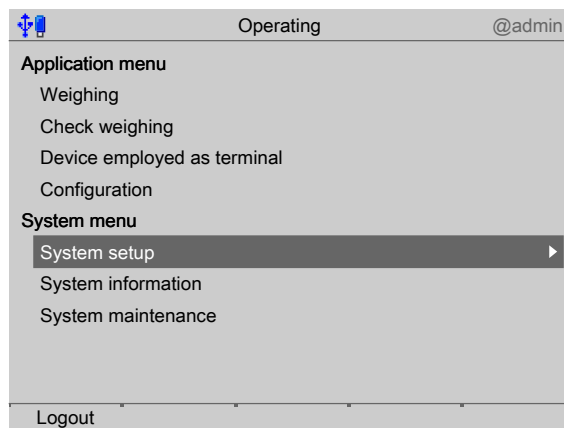

- ▶ Select and confirm [System setup].
- ▷ The system setup menu opens.

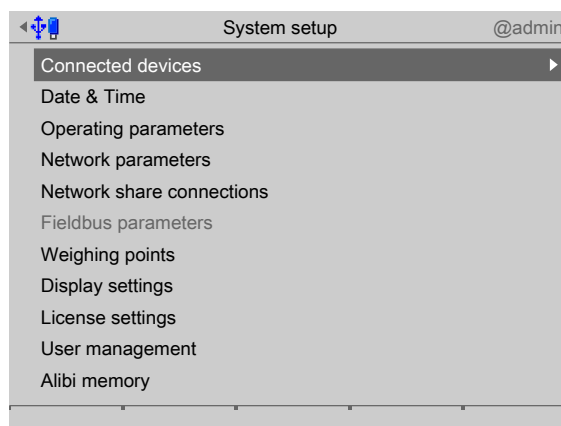

4.1 Connected devices

In this menu item (under **System setup**), the parameters for the connected devices are configured.

General devices

- [Remote display], see Chapter 4.1.1.
- [ModBus-RTU master], see Chapter 4.1.2.
- [PC via EW-Com], see Chapter 4.1.3.
- [Printer], see Chapter 4.1.4.
- [Remote terminal], see Chapter 4.1.5.
- [Barcode scanner], see Chapter 4.1.6.

Accessible via **MENU** - [Operating]- [System setup]- [Connected devices] .

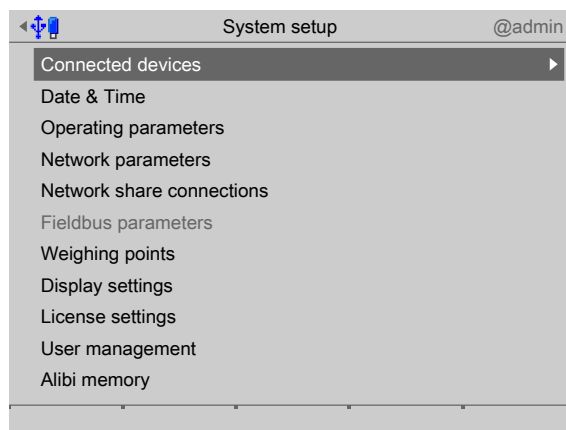

► Confirm [Connected devices].

▷ The connected devices menu opens.

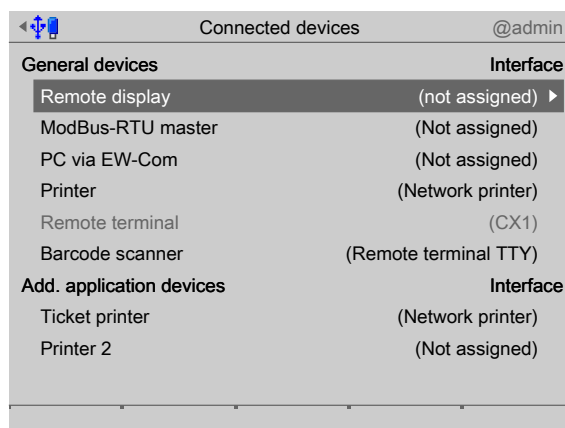

4.1.1 Remote display

In this menu item (under **Connected devices**), the parameters for a remote display are configured. A serial interface is used for connection.

Accessible via **MENU** - [Operating] - [System setup]- [Connected devices]- [Remote display] .

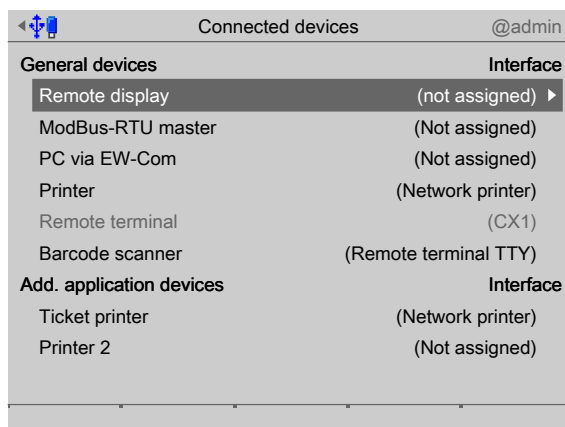

1. Confirm [Remote display].

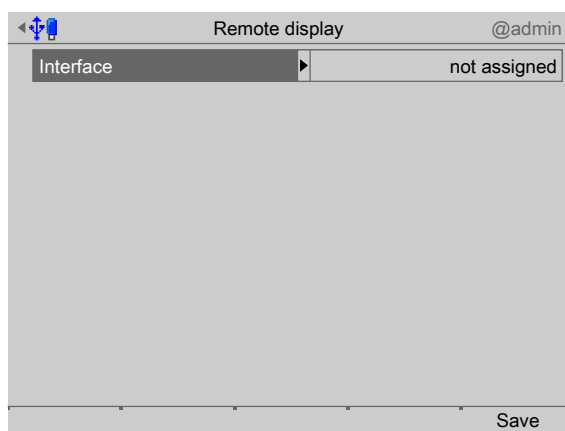

2. Select and confirm [Interface].

▷ A selection window opens.

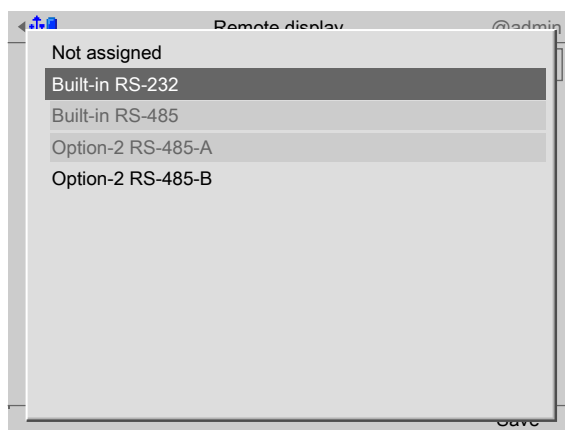

Inactive interfaces are grayed out.

3. Select and confirm the desired interface.

▷ A selection window opens.

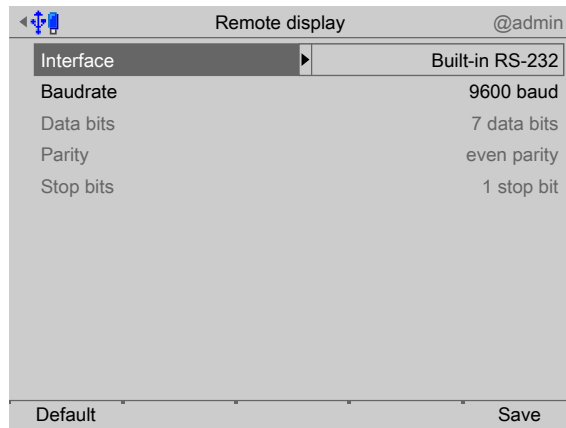

Inactive parameters are grayed out.

4. Select and confirm the desired parameters.

Only the baud rate can be adjusted here.

Selection: 300, 600, 1200, 2400, 4800, 9600, 19200 baud

Note:

The selected value must match the value of the connected device.

5. Press the [Save] soft key to save the settings.

4.1.2 ModBus-RTU master

In this menu item (under **Connected devices**), the parameters for a ModBus-RTU master are configured. A serial interface is used for connection.

A maximum of two digital scale protocols are possible if [Operating] - [System setup] - [Connected devices] - [ModBus-RTU master] has been selected in the menu.

Accessible via **MENU** - [Operating] - [System setup] - [Connected devices] - [ModBus-RTU master] .

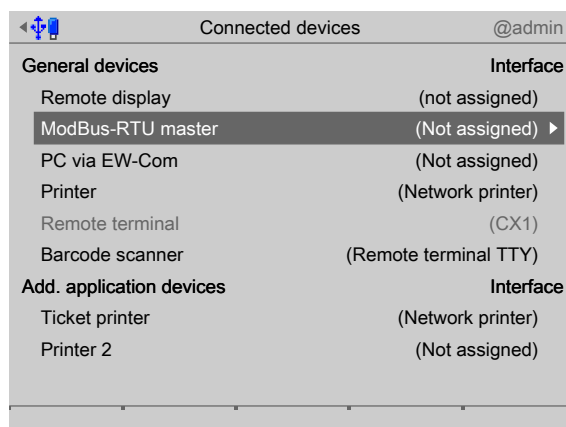

1. Select and confirm [ModBus-RTU master].

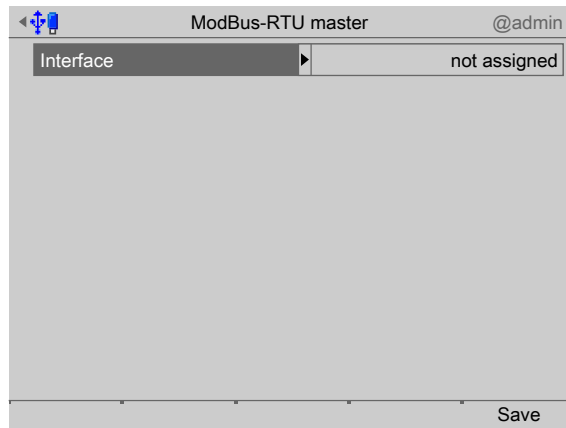

2. Select and confirm [Interface].

▷ A selection window opens.

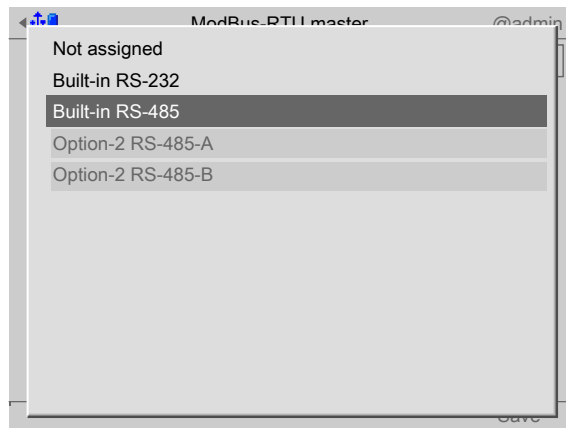

Inactive interfaces are grayed out.

3. Select and confirm the desired interface.

▷ A selection window opens.

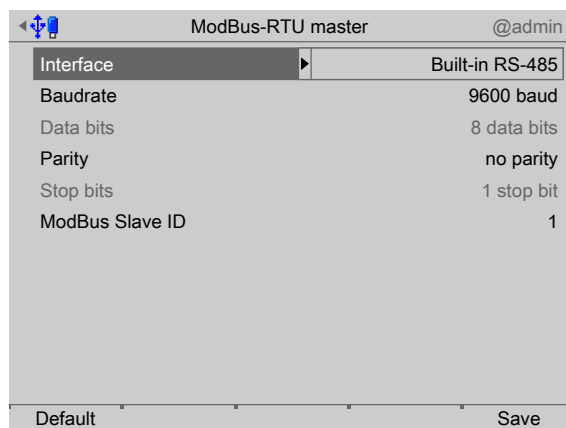

Inactive parameters are grayed out.

4. Select and confirm the desired parameters.

[Baud rate]

Baud rate of the data transfer.

Selection: 300, 600, 1200, 2400, 4800, [9600], 19200, 38400, 57600, 115200 baud

Note:

The selected value must match the value of the connected device.

[Parity]

Parity check for detecting errors during data transmission.

Selection: no parity, odd parity, even parity

[Modbus Slave ID]

Input: an address from 1...255

5. Press the [Save] soft key to save the settings.

4.1.3 PC via EW-Com

In this menu item (under **Connected devices**), the parameters for a PC via EW-Com are configured. A serial interface is used for connection.

Accessible via **MENU** - [Operating] - [System setup]- [Connected devices]- [PC via EW-Com] .

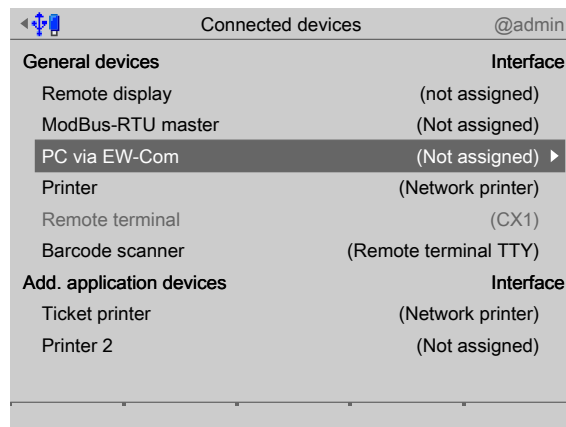

1. Select and confirm [PC via EW-Com].

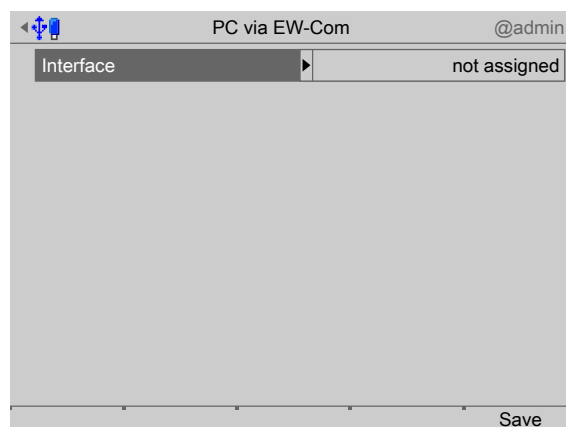

2. Select and confirm [Interface].
▷ A selection window opens.

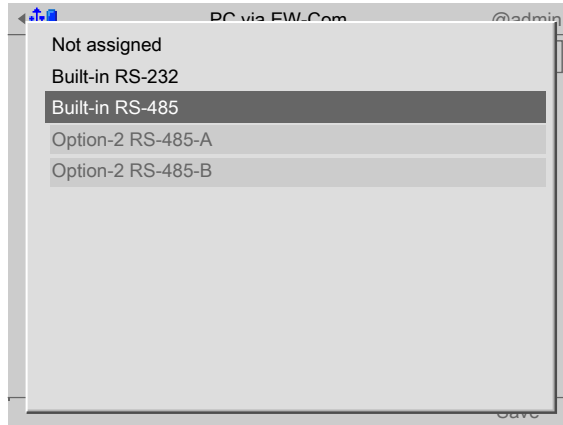

Inactive interfaces are grayed out.

3. Select and confirm the desired interface.

▷ A selection window opens.

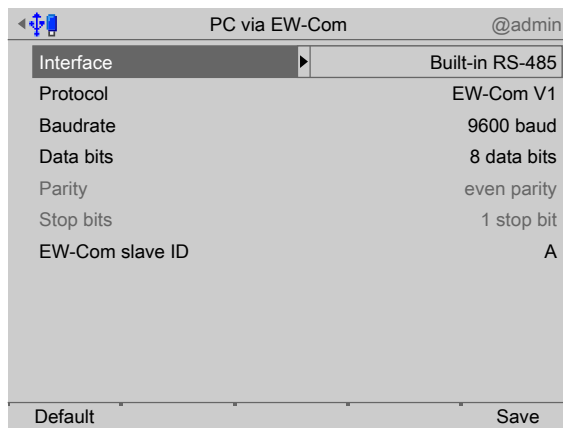

Inactive parameters are grayed out.

4. Select and confirm the individual parameters.

[Protocol]

Transmission protocol

Selection: EW-Com V1, EW-Com V2, EW-Com V3

V1 for old communication programs

V2 for recipe controller

V3 for OPC

[Baud rate]

Baud rate of the data transfer.

Selection: 300, 600, 1200, 2400, 4800, [9600], 19200, 38400, 57600, 115200 baud

Note:

The selected value must match the value of the connected device.

[Data bits]

Groups of data bits.

Selection: 7 data bits, [8 data bits]

[EW-Com slave ID]

Input: Address from A to Z.

5. Press the [Save] soft key to save the settings.

4.1.4 Printer

In this menu item (under **Connected devices**), the parameters for a printer are configured.

- [Serial printer], see Chapter [4.1.4.1](#).
- [Network printer], see Chapter [4.1.4.2](#).
- [Network share connection] (shared directory), see Chapter [4.1.4.3](#).
- [USB printer], see Chapter [4.1.4.4](#).
- [USB folder], see Chapter [4.1.4.5](#).

Accessible via **MENU** - [Operating] - [System setup]- [Connected devices]- [Printer] .

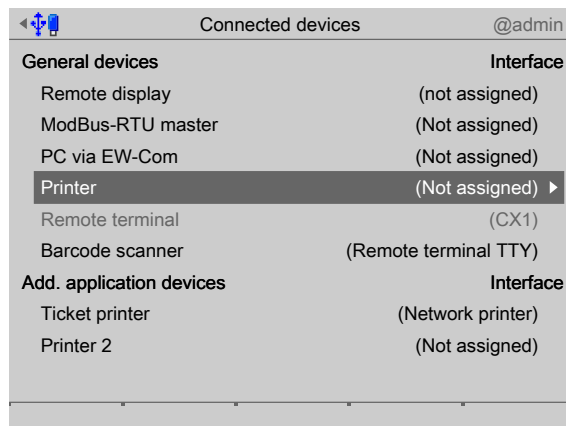

1. Select and confirm [Printer].

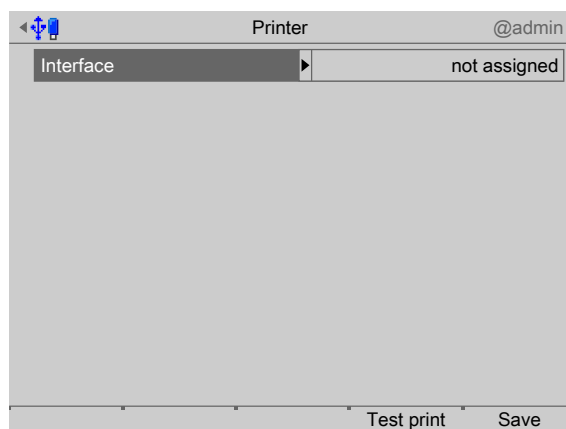

2. Select and confirm [Interface].
 - ▷ A selection window opens.

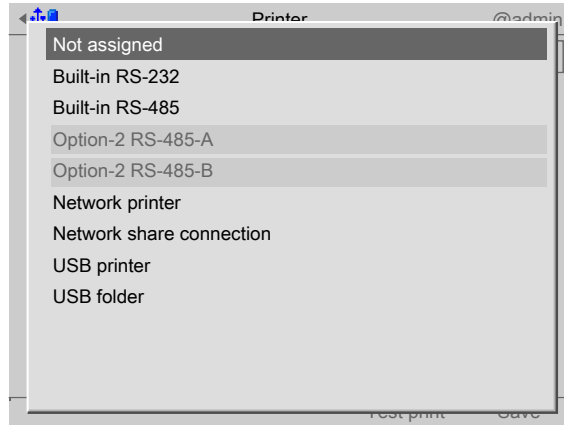

Inactive interfaces are grayed out.

The following printer interfaces are available:

- [Serial printer], see Chapter [4.1.4.1](#).
- [Network printer], see Chapter [4.1.4.2](#).
- [Network share connection] (shared directory), see Chapter [4.1.4.3](#).
- [USB printer], see Chapter [4.1.4.4](#).
- [USB folder], see Chapter [4.1.4.5](#).

3. Select and confirm the desired interface.

Note:

The printer defined here is also selected for the configuration printout of the application at the same time.

4.1.4.1 Serial printer

In this menu item (under **Printer**), the parameters for a printer at the serial interface are configured.

Accessible via **MENU** - [Operating]- [System setup]- [Connected devices]- [Printer]- [Interface]- [x RS-x] .

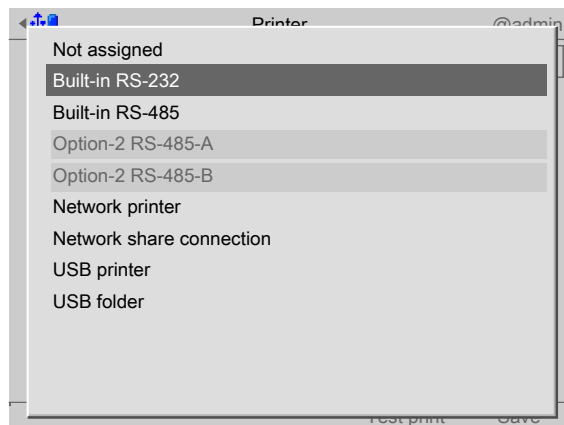

1. In this case: select and confirm [Built-in RS-232].
 - ▷ A selection window opens.

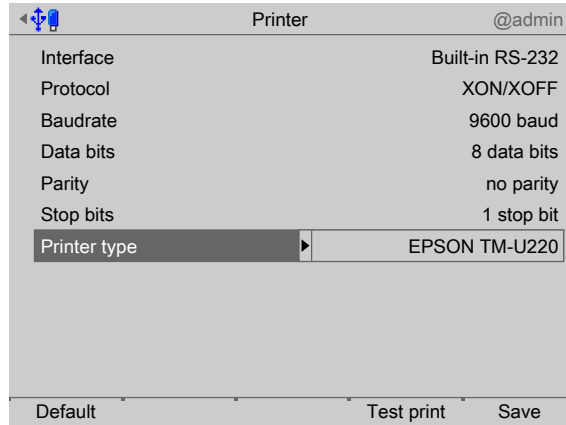

2. Select and confirm the individual parameters.

[Protocol]

Transmission protocol

Selection: no protocol, XON/XOFF, RTS/CTS

[Baud rate]

Baud rate of the data transfer.

Selection: 300, 600, 1200, 2400, 4800, [9600], 19200, 38400, 57600, 115200 baud

Note:

The selected value must match the value of the connected device.

[Data bits]

Groups of data bits.

Selection: 7 data bits, [8 data bits]

[Stop bits]

Units for transmission protocols.

Selection: 1 stop bit, [2 stop bits]

[Printer type]

The printer type depends on the printer: raw, CR/LF translation, EPSON TM-U220, EPSON LQ-300K, Generic PCL5 (Unicode), Generic PCL5 (codepage), Generic ESC/P2

3. Press the [Test print] soft key.
 - ▷ A test page (see Chapter 10.2) is printed.
4. Check the printer settings and change if necessary.
5. Press the [Save] soft key to save the settings.

4.1.4.2 Network printer

In this menu item (under **Printer**), the parameters for a network printer are configured. Accessible via **MENU** - [Operating] - [System setup] - [Connected devices] - [Printer] - [Interface] - [Network printer] .

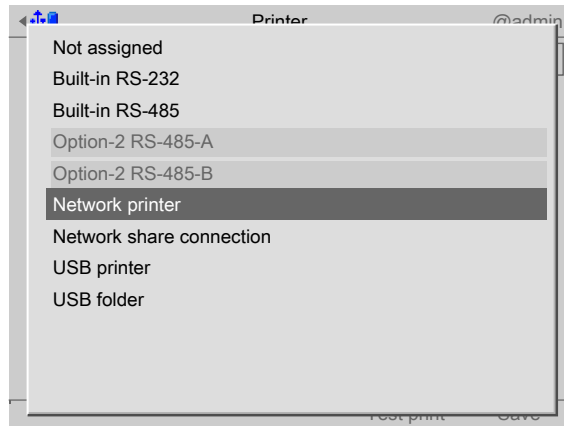

1. Select and confirm [Network printer].

▷ A selection window opens.

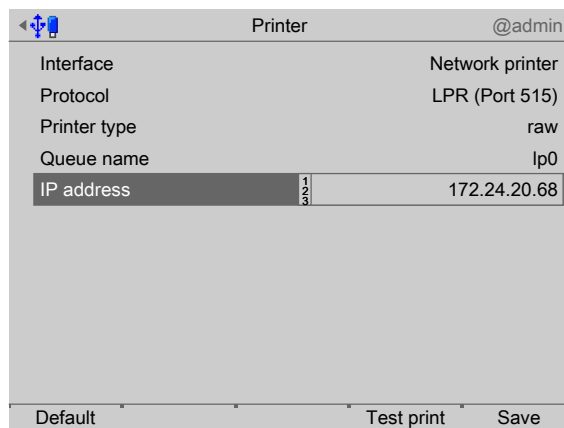

2. Select and confirm the individual parameters.

[Protocol]

Transmission protocol

Selection: consult the responsible system administrator. LPR (Port 515) or RAW (Port 9100)

[Printer type]

The printer type depends on the printer: raw, CR/LF translation, EPSON TM-U220, EPSON LQ-300K, Generic PCL5 (Unicode), Generic PCL5 (codepage), Generic ESC/P2

[Queue name]

The name can only be selected if [Protocol]- [LPR (Port 515)] is selected.

Selection: consult the responsible system administrator.

[IP address]

Selection: consult the responsible system administrator.

3. Press the [Test print] soft key.

- ▷ A test page (see Chapter 10.2) is printed.
- 4. Check the printer settings and change if necessary.
- 5. Press the [Save] soft key to save the settings.

4.1.4.3 Network share connection

In this menu item (under **Printer**), the parameters for a shared directory (network share connection) as a printer are configured.

Accessible via **MENU** - [Operating]- [System setup]- [Connected devices]- [Printer]- [Interface]- [Network share connection] .

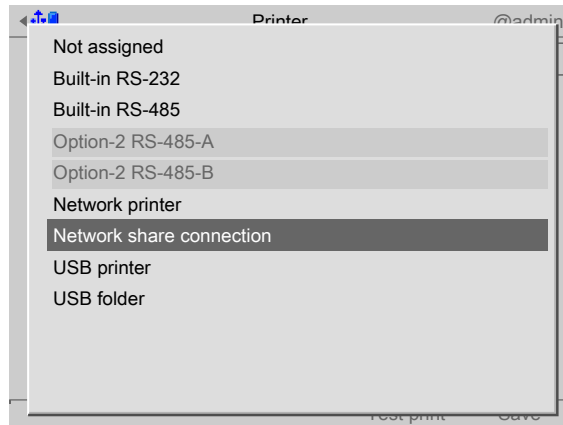

1. Select and confirm [Network share connection].
 - ▷ A selection window opens.

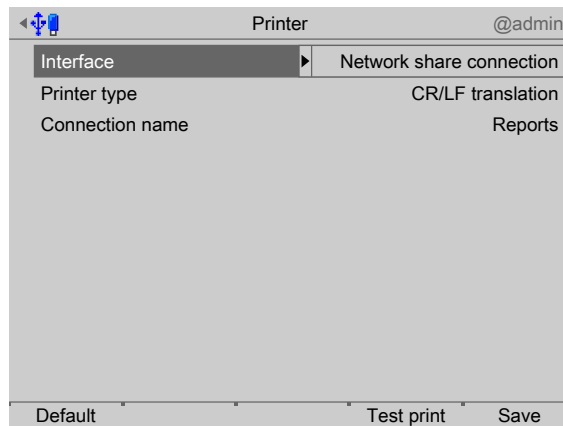

2. Select and confirm the individual parameters.

[Printer type]

The choice depends on the processing of the print file: raw, CR/LF translation, EPSON TM-U220, EPSON LQ-300K, Generic PCL5 (Unicode), Generic PCL5 (codepage), Generic ESC/P2

[Connection name]

Save location of the print file. At least one network share connection must be available; see Chapter 4.5.

3. Press the [Test print] soft key.
 - ▷ A test page (see Chapter 10.2) is printed.
4. Check the printer settings and change if necessary.

5. Press the [Save] soft key to save the settings.

4.1.4.4 USB printer

In this menu item (under **Printer**), the parameters for a printer at the USB interface are configured.

Accessible via **MENU** - [Operating]- [System setup]- [Connected devices]- [Printer]- [Interface]- [USB printer] .

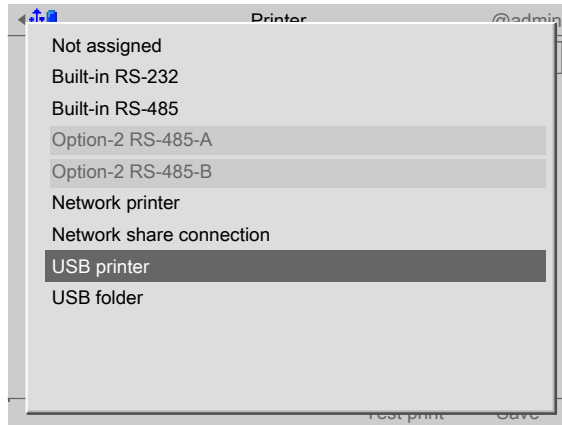

1. Select and confirm [USB printer].

▷ A selection window opens.

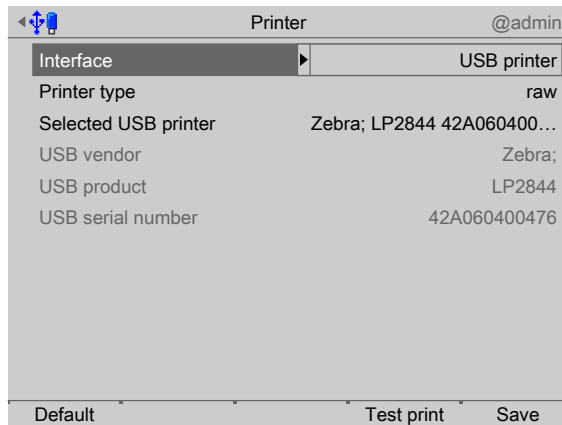

Inactive parameters are grayed out.

2. Select and confirm the individual parameters.

[Printer type]

The printer type depends on the printer: raw, CR/LF translation, EPSON TM-U220, EPSON LQ-300K, Generic PCL5 (Unicode), Generic PCL5 (codepage), Generic ESC/P2



3. Select and confirm [Selected USB printer].

▷ A selection window opens.

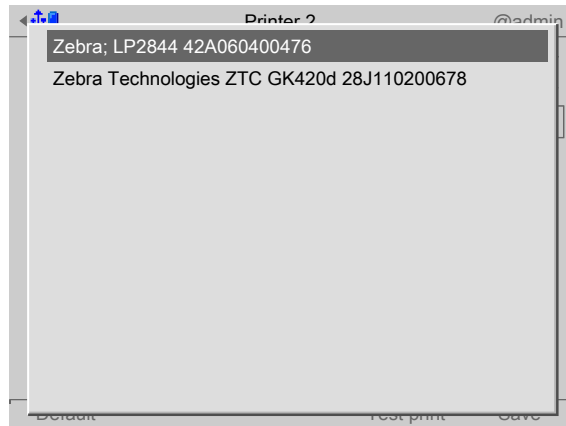

The connected printers (here: 2) can be selected.

4. Select and confirm the appropriate printer.
5. Press the [Test print] soft key.
 - ▷ A test page (see Chapter 10.2) is printed.
6. Check the printer settings and change if necessary.
7. Press the [Save] soft key to save the settings.

4.1.4.5 USB folder

In this menu item (under **Printer**), the parameters for a folder on a connected USB stick as a printer are configured.

Accessible via **MENU** - [Operating]- [System setup]- [Connected devices]- [Printer]- [Interface]- [USB folder] .

- ▷ A prompt window appears.

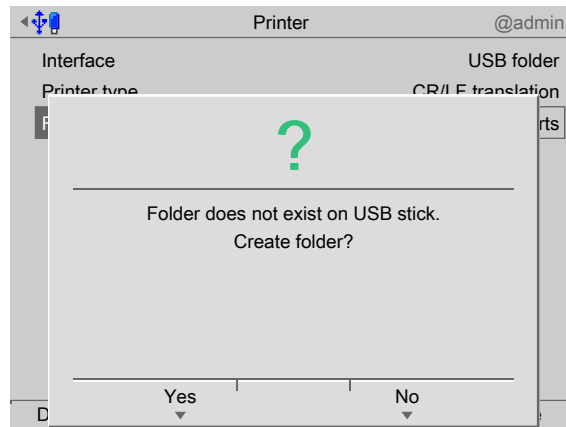

4. Press the [Yes] soft key.
 - ▷ A test file is created in the newly created folder.
5. Check the settings and change if necessary.
6. Press the [Save] soft key to save the settings.

4.1.5 Remote terminal

This menu item (under **Connected devices**) is displayed if Maxxis is equipped with CX1. Accessible via **MENU** - [Operating] - [System setup] - [Connected devices] - [Remote terminal].

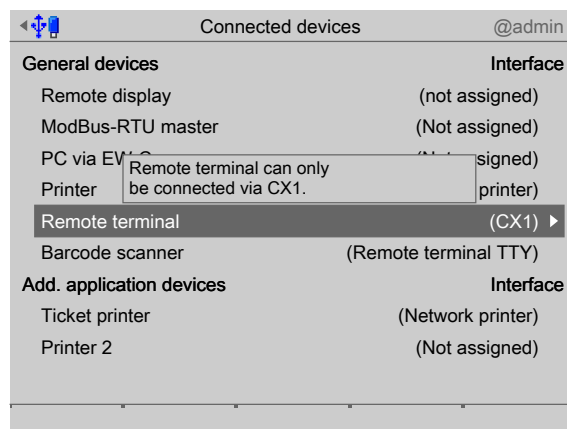

The interface used has no configurable parameters.

Note:

For further information, see PR 5900/6. and ../7. instrument manual.

4.1.6 Barcode scanner (with Ex approval)

In this menu item (under **Connected devices**), the parameters for a barcode scanner are configured.

The barcode scanner is directly connected to the remote terminal PR 5900/60 or ../70.

The scanner can only be used if option CX1 is set in Maxxis.

Accessible via **MENU** - [Operating]- [System setup]- [Connected devices]- [Barcode scanner].

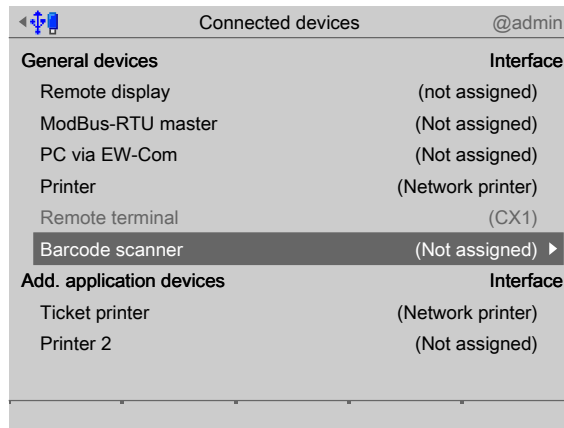

1. Select and confirm [Barcode scanner].

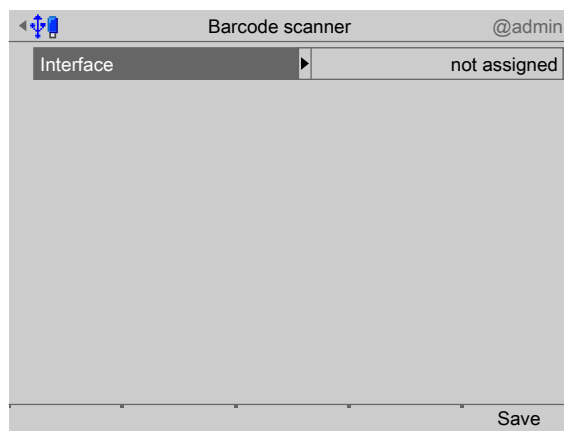

2. Select and confirm [Interface].
 - ▶ A selection window opens.

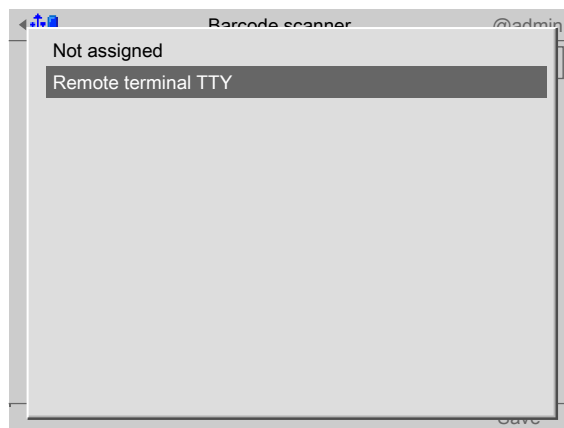

3. Select and confirm [Remote terminal TTY].
 - ▶ A selection window opens.

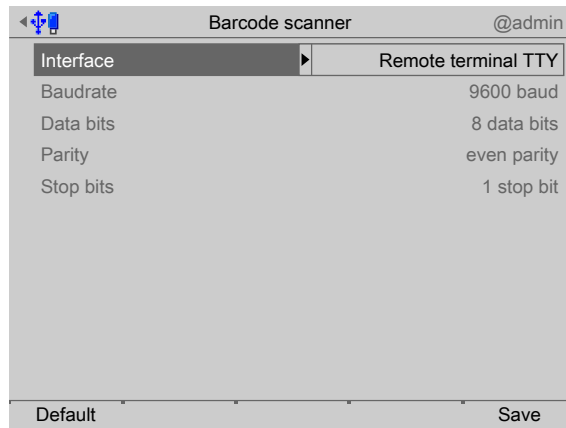

Inactive parameters are grayed out.

4. Press the [Save] soft key to save the settings.

4.2 Date & time

In this menu item (under **System setup**), the parameters for the date & time are configured.

Accessible via **MENU** - [Operating] - [System setup]- [Date & Time] .

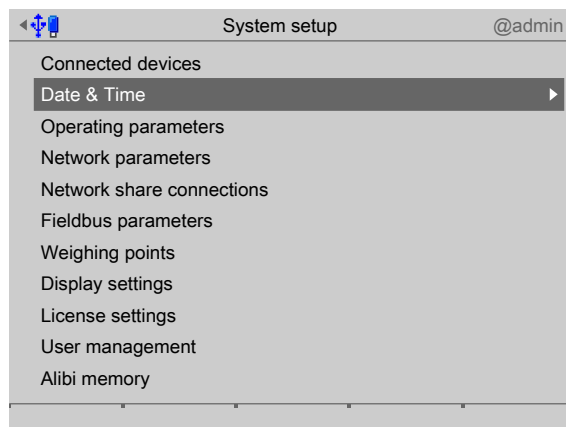

1. Select and confirm [Date & Time].

▷ A selection window opens.

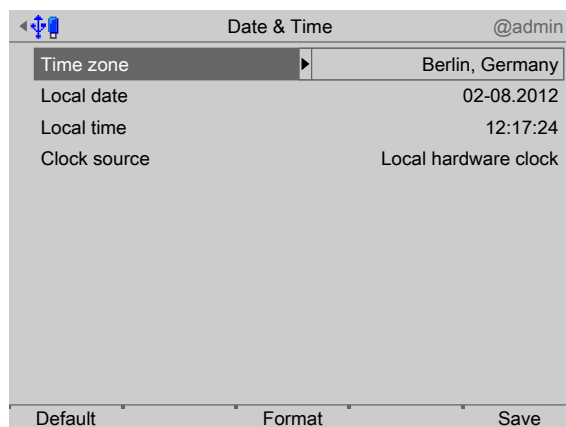

2. Select the individual parameters and confirm.

[Time zone]

Selection: all existing time zones

[Local date]

Can be configured if [Clock source]- [Local hardware clock] has been selected.

Input: via keyboard

[Local time]

Can be configured if [Clock source]- [Local hardware clock] has been selected.

Input: via keyboard

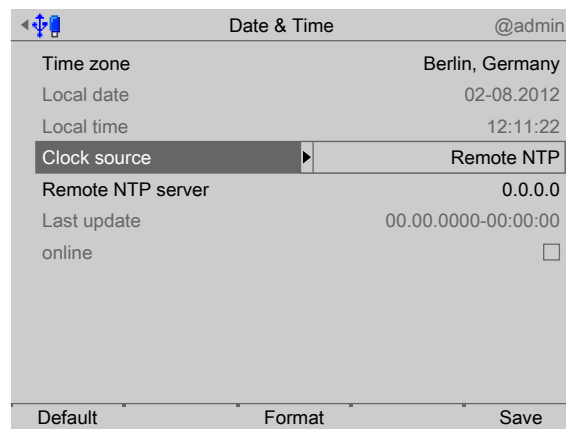
**[Clock source]**

Selection: local hardware clock, remote NTP (Network Time Protocol)

[Remote NTP server]

The IP address can only be entered if [Clock source]- [Remote NTP] (Network Time Protocol) has been selected.

Input: IP address via keyboard

[Last update]

Indicates when the last data was received by the remote NTP.

[online]

The checkbox indicates whether the remote NTP was successfully contacted during the last attempt.

3. Press the [Format] soft key to set the format parameters.
 - ▷ A selection window opens.

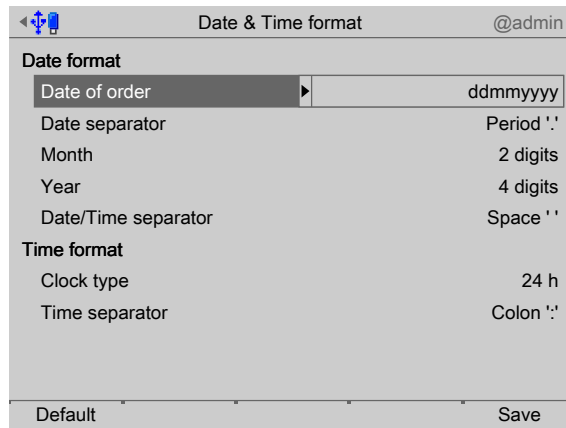

4. Select the individual parameters and confirm.

[Date order]

Selection: mmddyyyy, ddmmyyyy, yyyyymmdd, yyyyddmm

d = day, m = month, y = year

[Date separator]

Selection: Slash /, Hyphen -, Period '!', Space, Japanese 年月日, None

[Month]

Selection: 2 digits, 3 characters

[Year]

Selection: 2 digits, 4 digits

[Date/Time separator]

Selection: Hyphen -, Space, None

[Clock type]

Selection: 12 h, 24 h

[Time separator]

Selection: Colon :, Hyphen -, Japanese 時分秒, None

5. Press the [Save] soft key to save the settings.

4.3 Operating parameters

In this menu item (under **System setup**), the operating parameters are configured.

Accessible via **MENU** – [Operating] - [System setup] - [Operating parameters].

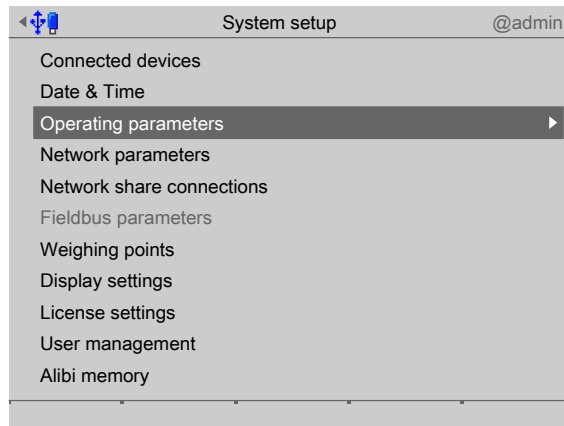

1. Select and confirm [Operating parameters].
 ▷ A selection window opens.

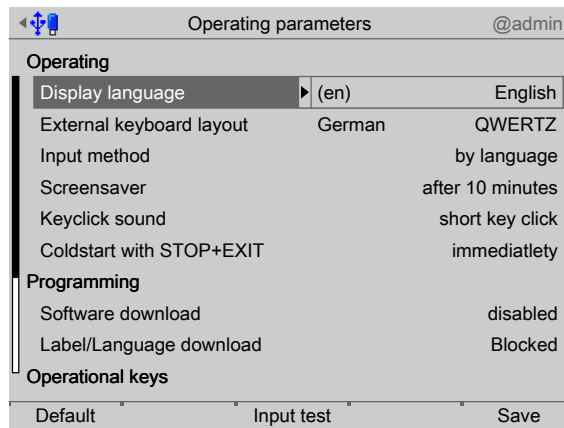

2. Select and confirm the individual parameters.

Note:

When user management is activated, the settings for the logged-in user remain active.

[Display language]

Selection: (de) German, [(en) English], [(fr) French]

Note:

When user management is activated, the operating language only changes once the currently logged-in user logs out. It is only possible to switch languages immediately using the F1 or F2 key.

[External keyboard layout]

Selection: [English QWERTY], German QWERTZ, French AZERTY, Italian QWERTY, Spanish QWERTY, Russian QWERTY/йцукен

Note:

This parameter applies in the case of a connected USB keyboard.

If a remote terminal is connected to Maxxis, this parameter also applies in the case of a PS2 keyboard attached to the remote terminal.

[Input method]

This function makes it possible to enter Japanese (Hepburn) or Chinese (Pinyin) characters even if the language in question (Japanese or Chinese) is not selected or another language (such as English) has been selected under [Display language].

Selection: [by language], Hepburn (transliteration of Japanese "Hiragana" characters into Latin script), Pinyin (phonetic transliteration based on the Latin alphabet)

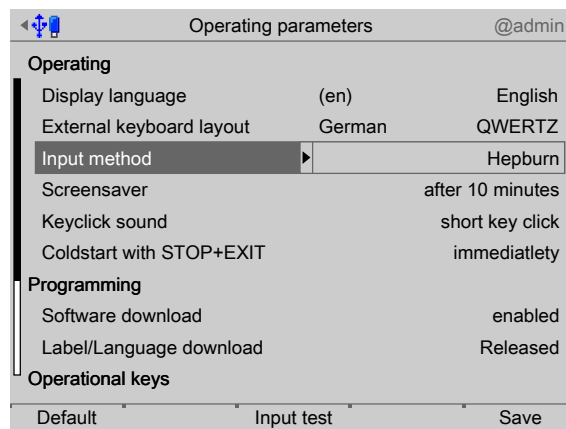
Input test for keyboard and keypad

3. Press the [Input test] soft key to test the entry.
 ▷ An input window opens.

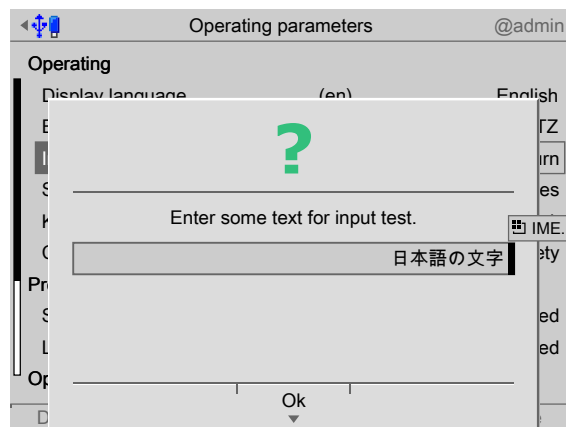

4. Enter the desired characters.



During the input test using the keypad, pressing the key on the device switches between:

- in this case: Hepburn
- Numbers
- Uppercase letters
- Lowercase letters

5. Press the [OK] soft key to end the input test.

[Screensaver]

Once the screensaver is switched on, operation is only possible once a password has been entered or a key has been pressed.

Selection: [no screensaver], after 1 minute, after 5 minutes, after 10 minutes, after 30 minutes

[Keyclick sound]

Duration of acoustic signal when keys are pressed

Selection: no key click, [short key click], medium key click, long key click

[Cold start with STOP+EXIT]

NOTICE

Data loss

A cold start leads to a loss of all data in the database.

- ▶ Back the data up first if necessary.

Selection: [disabled], immediately, 3 s

[Software download]

Load and start a new application on the device via the network.

NOTICE

Possible production downtime!

- ▶ This parameter must always be set to [disabled] for production systems.

Selection: [disabled], enabled

Software can only be downloaded in running operation when [enabled] has been selected.

[Label/Language download]

Load labels and language files onto the device via the network.

Note:

After a cold start, the files will be lost.

It is possible to permanently load the language files to the device using the update software "FlashIt" from version 02.73.11 upwards.

Selection: [disabled], enabled

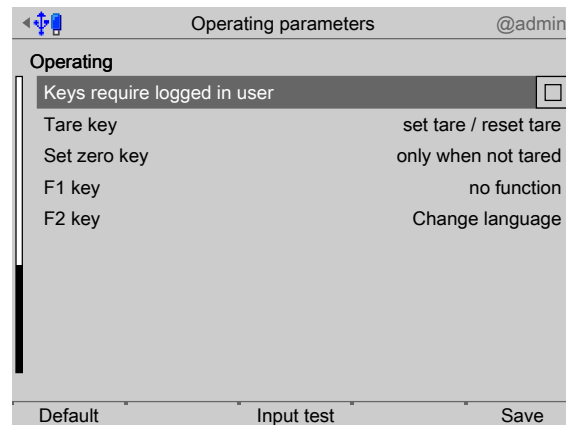
[Keys require logged in user]

If the checkbox is ticked, the keys with weighing point functions (e.g. set zero; F1 and F2, if configured for weighing point function) are disabled for users who are not logged in.

[Tare key]

The function of the tare key  can be configured.

Selection: disabled, [set tare / reset tare], set tare / set tare again

[Disabled] means that the key has no function.

[Set tare / reset tare] means that the device will be tared if it has not been tared previously and the tare will be reset if the device has already been tared.

[Set tare & set tare again] means that each time a key is pressed, the instant value in the tare memory is applied and the net display switches to 0.

[Set zero key]

The function of the set zero key  can be configured.

Selection: disabled, [only when not tared], reset tare on zero set

[Disabled] means that the set zero key on the keypad has no function.

The key's function can be limited to gross mode with [only when not tared] or switched automatically to gross mode with [reset tare on zero set].

If the set zero key with these settings has no effect, the configured zeroset range (around the zero point set with the dead load) is already utilized due to a previous zero-setting operation and/or automatic zero setting (see Chapter [4.7.1.1](#)).

[F1 key], [F2 key]

Selection: [No function], Change language, Change user, Lock device, Toggle weight unit, Set tare, Reset tare, Set tare / reset tare, Set tare / zero set, Analog test, Show 10x resolution

Note:

Weighing point functions are only active when the weight display is switched on.

Selection	Function
No function	Key has no function.
Change language	Menus are immediately shown in the selected language.
Change user	Login window appears on the display.
Lock device	This function is only available when user management is activated.
Toggle weight unit	Toggle between the display units (see Chapter 4.7.1.3). This function is only possible if at least two units have been selected.
Set tare	Current gross weight is saved in the tare memory.
Reset tare	Switch to gross mode.
Set tare / reset tare	The device will be tared if it has not been tared previously and the tare will be reset if the device has already been tared.
Set tare / zero set	The device will be tared if it has not been tared previously and the display will be set to 0.
Analog test	The selected analog weighing point is tested only when the current weight is displayed.
Show 10x resolution	The weight value is briefly displayed with 10x resolution.

6. Press the [Save] soft key to save the settings.

4.4 Network parameters

In this menu item (under **System setup**), the network parameters are configured. Accessible via **MENU** - [Operating]- [System setup]- [Network parameters] .

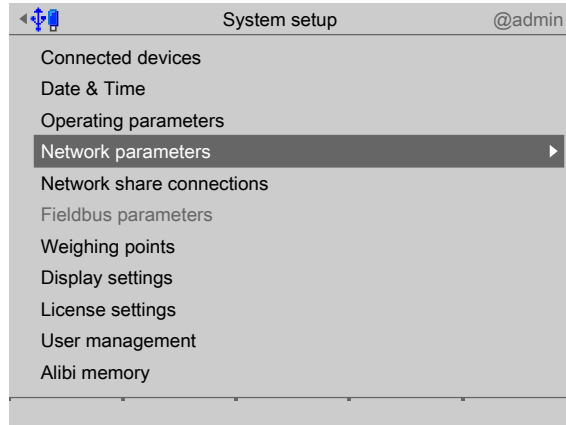

1. Select and confirm [Network parameters].

▷ A selection window opens.

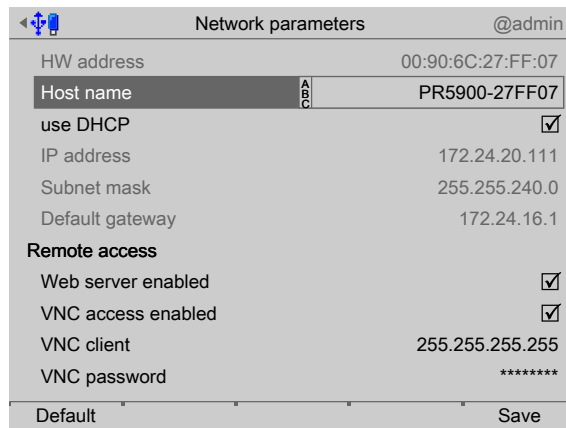

Inactive parameters are grayed out.

2. Select the individual parameters and confirm.

[HW address]

Fixed address determined by the device.

[Host name]

NOTICE

The host name must be unique in the network!

Always follow the IT security guidelines.

▶ Use unique host names.

The user-defined device name is subject to the following restrictions:

- Minimum number of characters: 2, maximum number of characters: 24.
- The first character must be a letter. Spaces are not permitted.
- 0-9, A-Z (not case-sensitive) are permitted.
- – or . may be included, but neither at the end nor in succession.

Input: via keyboard

[use DHCP]

If is checked (default setting: DHCP selected), the server automatically allocates the IP address, subnet mask, and default gateway.

If no checkbox is ticked, the settings for the [IP address], [Subnet mask] and [Default gateway] must be defined in conjunction with the responsible system administrator.

Network parameters		@admin
HW address	00:90:6C:27:FF:07	
Host name	PR5900-27FF07	
use DHCP	<input checked="" type="checkbox"/>	
IP address	172.24.20.111	
Subnet mask	255.255.240.0	
Default gateway	172.24.16.1	
Remote access		
Web server enabled	<input checked="" type="checkbox"/>	
VNC access enabled	<input checked="" type="checkbox"/>	
VNC client	255.255.255.255	
VNC password	*****	
Default	Save	

[Web server enabled]

If the checkbox is ticked, the device website can be used.

[VNC access enabled]

If the checkbox is ticked, the device can be operated via VNC.

[VNC client]

This address can be used to allow access to the interface.

Address	Access
172.24.21.101	only from client machine with this address.
172.24.21.255	from any client with address within range 172.24.21.1...172.24.21.254.
255.255.255.255	from a client with any address

[VNC password]

If a password is entered (max. 8 characters), this password must be entered in the VNC client to access the interface.

[Default] soft key

- resets the host name to PR5900-XXXXXX, where XXXXXX stands for the last 3 bytes of the hardware address (MAC ID).
- sets [use DHCP] to active.
- sets the IP address to 0.0.0.0.
- sets the subnet mask to 0.0.0.0.
- sets the default gateway to 0.0.0.0.
- sets the VNC client to 255.255.255.255.
- resets the VNC password to [no password].

Note:

Blackbox device: DHCP is deactivated and the fixed IP address 192.168.1.2 is set; see also Chapter [2.8.2](#).

3. Press the [Save] soft key to save the settings.

4.5 Network share connections

In this menu item (under **System setup**), the parameters for shared directories (network share connections) are configured and made available for system maintenance (e.g. storing/saving data on the network).

- [Add], see Chapter [4.5.1](#).
- [Change], see Chapter [4.5.2](#).
- [Remove], see Chapter [4.5.3](#).

The following **order** must be observed without exception:

- One or more directories on the server/notebook/PC must be shared; see the manual for the operating system in question (e.g., Windows 7: click the directory, right-click on [Advanced Sharing...] and activate [Share this folder]. Then click [OK].)
- In the menu [Operating]- [System setup]- [Network share connections] , configure the connections to the shared directories on the server/notebook/PC.

Accessible via **MENU** - [Operating]- [System setup]- [Network share connections] .

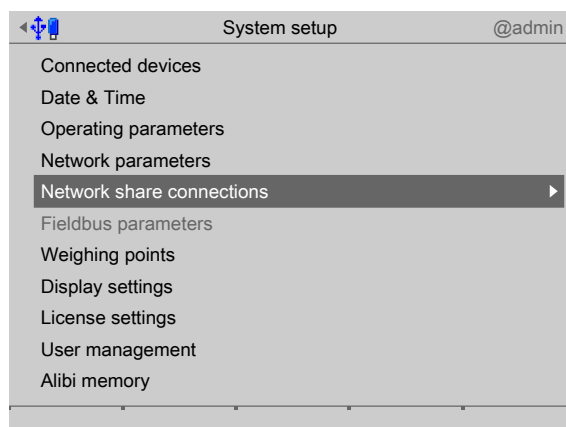

- ▶ Select and confirm [Network share connections].

- ▷ The window listing the available network share connections opens.

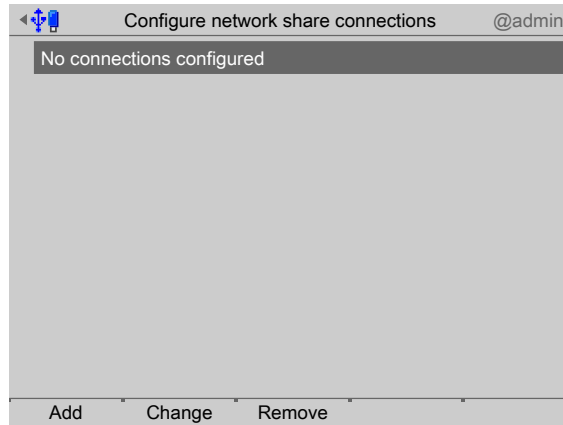

4.5.1 Add

In this menu item (under **Network share connections**), the parameters for shared directories (network share connections) are configured and added.

Accessible via **MENU** - [Operating]- [System setup]- [Network share conditions]- [Add] .

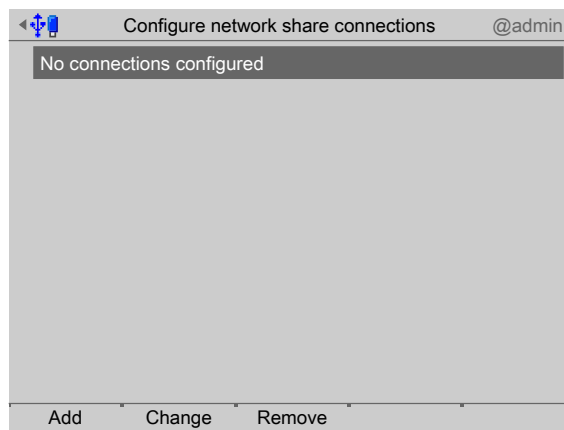

The list is empty because no connections have been configured yet.

1. Press the [Add] soft key.
 - ▷ A selection window opens.

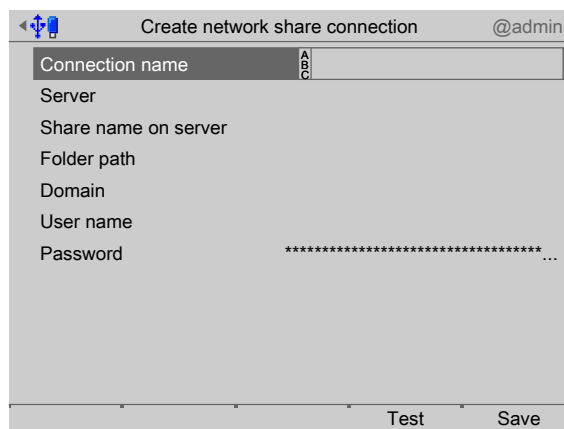

2. Select the individual parameters and confirm.

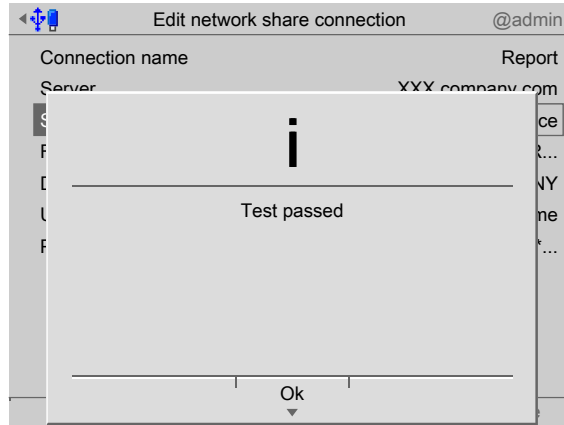

4. Press the [OK] soft key to hide the window.
If an error message appears, the configuration must be changed.
5. Press the [Save] soft key to save the settings.
 - ▷ The newly configured connection (here: Report) is displayed.

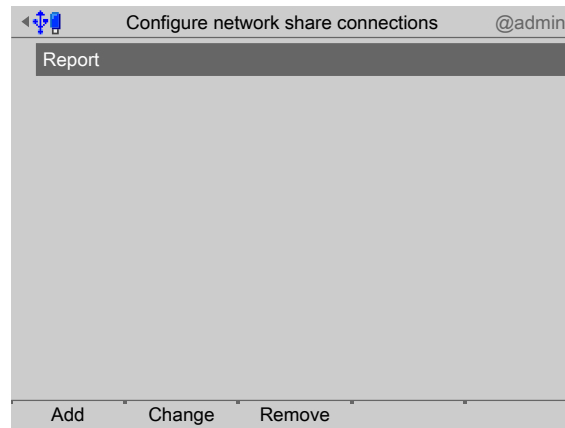

4.5.2 Change

In this menu item (under **Network share connections**), the parameters for configured shared directories (network share connections) are modified.

Accessible via **MENU** - [Operating]- [System setup]- [Network share conditions]- [Change].

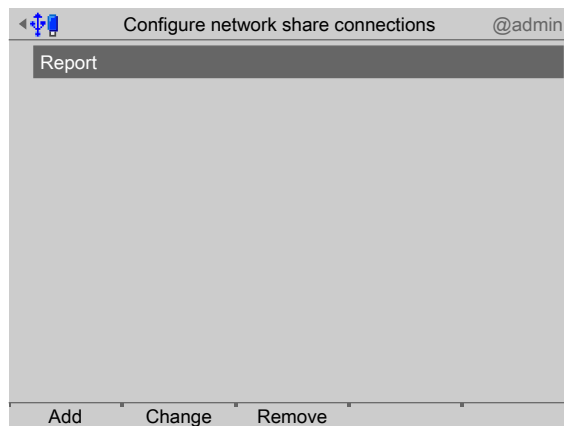

1. Select the desired connection.

2. Press the [Change] soft key.
 - ▷ A selection window opens.

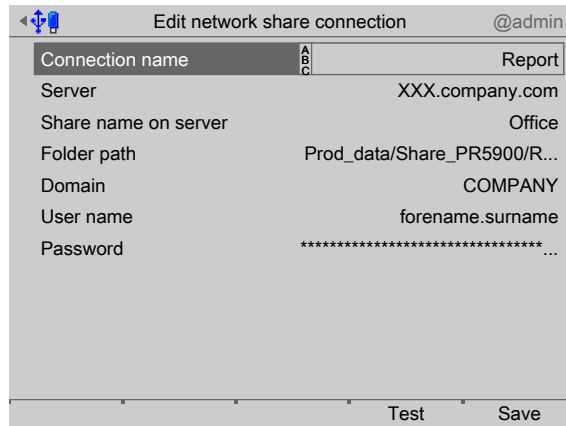

3. Select the individual parameters, confirm and modify if required, see Chapter 4.5.
4. Press the [Test] soft key to test the connection.
5. Change the configuration again if necessary.
6. Press the [Save] soft key to save the settings.

4.5.3 Remove

In this menu item (under **Network share connections**), the parameters for configured shared directories (network share connections) are removed/deleted.

Note:

Only the settings in the device are deleted.
No network share files are deleted.

Accessible via **MENU** – [Operating] - [System setup] - [Network share connections] - [Remove].

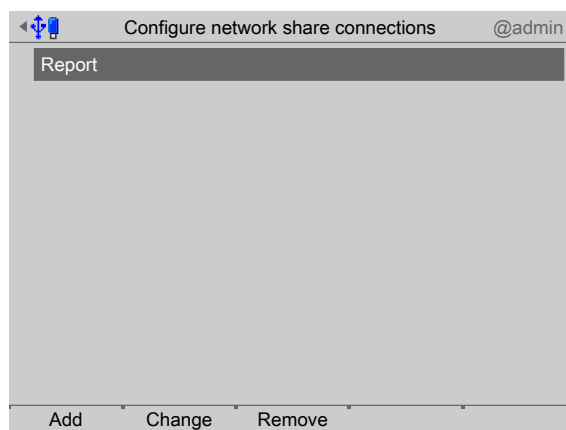

1. Select the desired connection.
2. Press the [Remove] soft key
 - ▷ A prompt window opens.

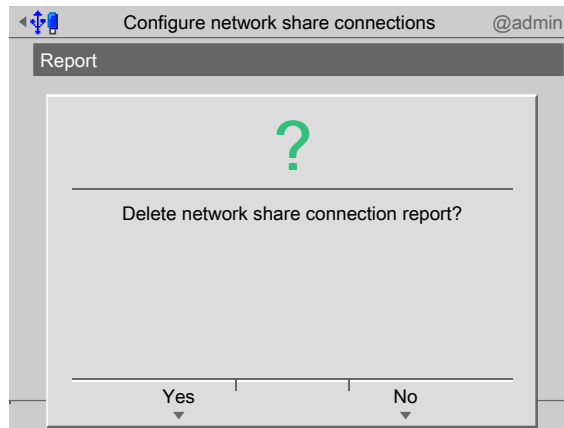

3. Press the corresponding soft key.

4.6 Fieldbus parameters

In this menu item (under **System setup**), the parameters for the fieldbus card used are configured.

This menu item can only be selected if a fieldbus card has been installed in Option FB.

Depending on the fieldbus card used, the corresponding **fieldbus protocol** appears automatically:

- [Profibus-DP] for PR 1721/51
- [DeviceNet] for PR 1721/54
- [CC-Link] for PR 1721/55
- [ProfiNet I/O] for PR 1721/56 and PR 1721/76
- [EtherNet IP] for PR 1721/57 and PR 1721/77

Note:

The protocol for the scale interface is described in Chapter [8.2](#).

The protocol for the SPM interface is described in Chapter [8.3](#).

Accessible via **MENU** – [Operating] - [System setup] - [Fieldbus parameters].

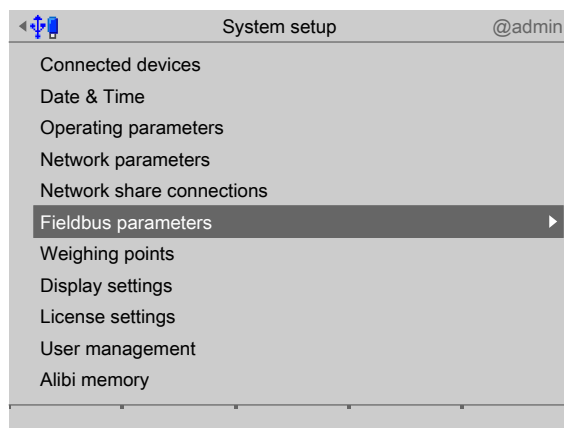

1. Select and confirm [Fieldbus parameters].

▷ A selection window opens.

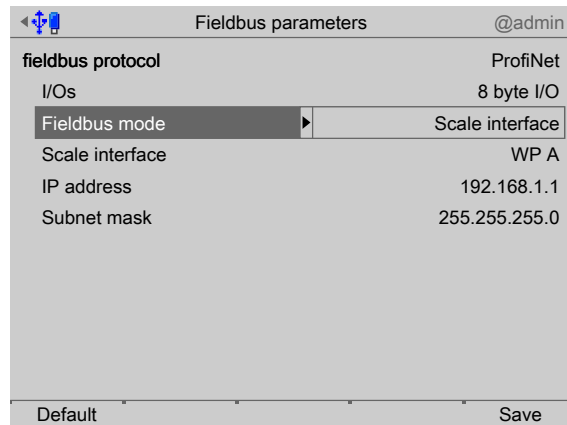

2. Select and confirm the individual parameters.

The parameters are dependent on the relevant fieldbus (here: ProfiNet).

[I/Os]

Selection: 8 to 256 Byte I/O

[Fieldbus operating mode]

Selection: Only application, scale interface, SPM interface

[Only application] is selected for project applications.

[Scale interface] is selected if scale and application values are exchanged via the fieldbus interface.

[SPM interface] is selected if the SPM needs to be accessed via the fieldbus interface.

[Scale interface]

Selection: disabled; WP A (equals 8 bytes); WP A, B (equals 16 bytes); WP A, B, C (equals 24 bytes); WP A, B, C, D (equals 32 bytes)

Network-based field bus protocols:

[IP address]

Input: via keyboard

[Subnet mask]

Input: via keyboard

Profibus-DP:

[Profibus-DP address]

Input: via keyboard

3. Press the [Save] soft key to save the settings.

4.6.1 Fieldbus settings for the SPS

Configuration of the interface is carried out in the device under [System setup] - [Fieldbus parameters], see Chapter 4.6.

Requirements:

- The relevant fieldbus card has been installed, see PR 5900 installation manual.
- The parameters have been selected and saved according to the weighing points (1x WP = 8 byte I/O), see Chapter 4.6.
- The corresponding device description data has been loaded to the SPS development environment, see PR 5900 installation manual.
 - ProfiBus-DP: xx_xx.gsd
 - DeviceNet: xx_xx.eds
 - CC-Link: 0x0608_Maxxis_x_x.xx_en.CSPP
 - ProfiNet I/O: GSDML-xx-xx-xx-xx.xml
 - EtherNet-IP: xx_xx_xx.eds

Card test:

The fieldbus cards have LEDs that display their status, see PR 5900 installation manual.

All inputs and outputs are displayed in the menu [Operating] - [System maintenance] - [Test hardware] - [I/O cards test] - [Option FB].

NOTICE

Potential network problems

- ▶ A unique device name must be assigned for the hardware configuration and assignment/download.

4.7 Weighing points

In this menu item (under **System setup**), the corresponding weighing electronics are assigned to a logical weighing point and configured.

- [Internal weighing point], see Chapter 4.7.1.
- [Liquid counter], see Chapter 4.7.2.
- [User scale], see Chapter 4.7.3.
- [xBPI scale], see Chapter 4.7.5.
- [SBI scale], see Chapter 4.7.6.
- [Pendeo Truck], see Chapter 4.7.7.
- [Pendeo Process], see Chapter 4.7.8.
- [PR-Net weighing point], see Chapter 4.7.9.
- [Mettler-Scale], see Chapter 4.7.10.
- [SMA scale], see Chapter 4.7.11.

The device can manage up to four weighing points (scales). The number of scales to be used is determined by the application package. There are physical weighing electronics/

scales (e.g. [internal], [xBPI scale]) and logical weighing points (WP A, WP B, WP C, and WP D).

A totalization of two scales can only take place on C = A+B.

Restrictions when selecting scale protocols:

- A maximum of three digital scale protocols (excluding SBI) are possible at the same time:
 - xBPI
 - Pendeo
- A maximum of two digital scale protocols are possible if [Operating] - [System setup] - [Connected devices] - [ModBus-RTU master] has been selected in the menu.

The physical weighing point can be assigned to a logical weighing point in the menu [Operating] - [System setup] - [Weighing points] in accordance with the following table:

Weighing electronics	Logical weighing point			
	WP-A	WP-B	WP-C	WP-D
[not assigned]	W	W	W	W
[Internal weighing point]	W	W	-	-
[A+B]	-	-	W	-
[Liquid counter]	W	W	W	W
[User scale]	W	W	W	W
[xBPI scale]	W	W	W	W
[SBI scale]	W	W	W	W
[Pendeo Truck]	W	W	W	W
[Pendeo Process]	W	W	W	W
[PR-Net weighing point]	W	W	W	W
[Mettler-Scale]	W	W	W	W
[SMA scale]	W	W	W	W

When the PR 5900 internal weighing electronics are plugged into the slots for A or B, they are automatically assigned to weighing point A or B, respectively.

Weighing electronics can only be assigned to a logical weighing point once.

WP-A is displayed as the factory setting.



This key can be used to switch the display to the desired weighing point.

Accessible via **MENU** – [Operating] - [System setup] - [Weighing points].

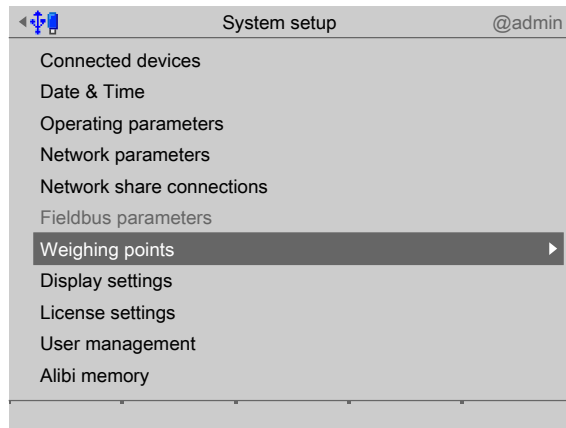

- ▶ Select and confirm [Weighing points].
- ▷ The Weighing points menu appears.

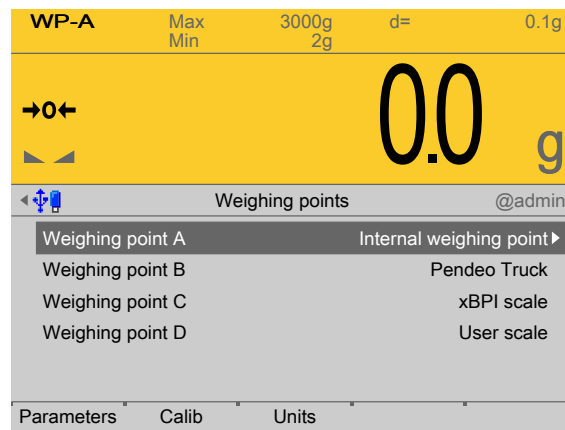

4.7.1 Internal weighing point

In this menu item (under **Weighing points**), the weighing electronics of an **internal weighing point** are assigned to a logical weighing point and configured.

- [Parameters] (weighing electronics), see Chapter [4.7.1.1](#).
- [Calib], see Chapter [4.7.1.2](#).
 - [New], see Chapter [4.7.1.2.1](#).
 - [Modify] (for small changes only), see Chapter [4.7.1.2.2](#).
- [Units] (display units and display accuracy), see Chapter [4.7.1.3](#).

Accessible via **MENU** – [Operating] - [System setup] - [Weighing points] - [Weighing point x] - [Weighing point] - [Internal weighing point] .

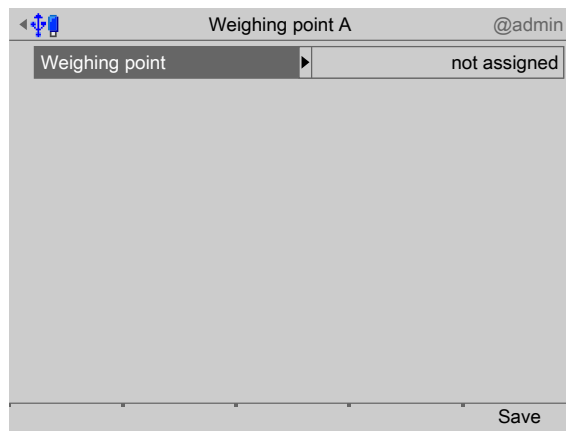

1. Confirm [Weighing point].
 - ▷ A selection window opens.

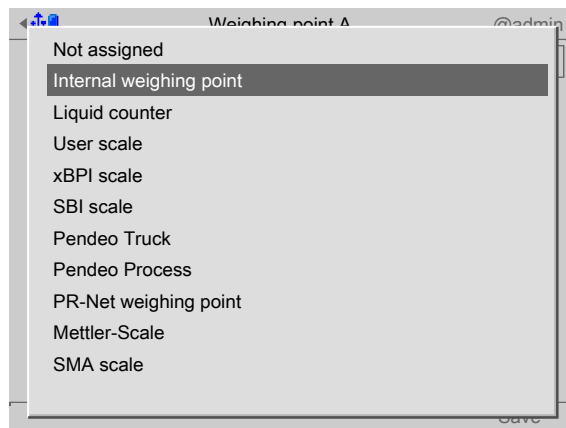

2. Select and confirm [Internal weighing point].
3. Press the [Save] soft key to save the settings.
 - ▷ The weighing electronics are now assigned to the weighing point.

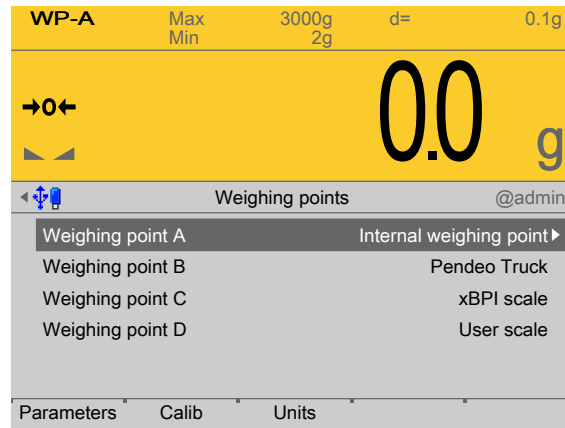

4.7.1.1 Parameters

In this menu item, the parameters for the **Internal weighing point** weighing electronics are configured.

For detailed descriptions of the following parameters:

- [W&M] (legal metrology), see Chapter [4.7.1.1.1](#).
- [Range mode] (range selection for scales), multi-range, see Chapter [4.7.1.1.2](#) and multi-interval scale, see Chapter [4.7.1.1.3](#)

Accessible via **MENU** - [Operating] - [System setup] - [Weighing points] - [Weighing point x] - [Parameters] .

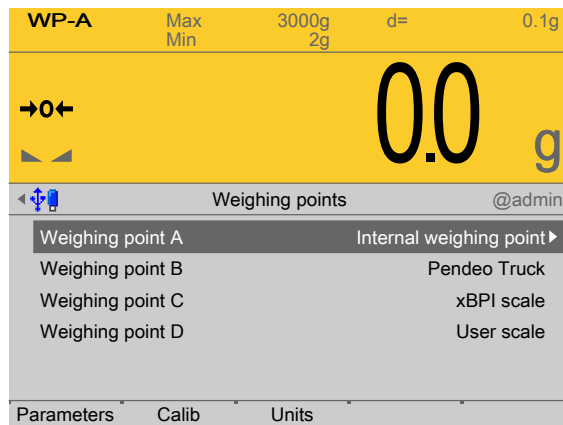

1. In this case: Select [Weighing point A] with [Internal weighing point] and press the [Parameters] soft key.
 - ▷ A selection window opens.

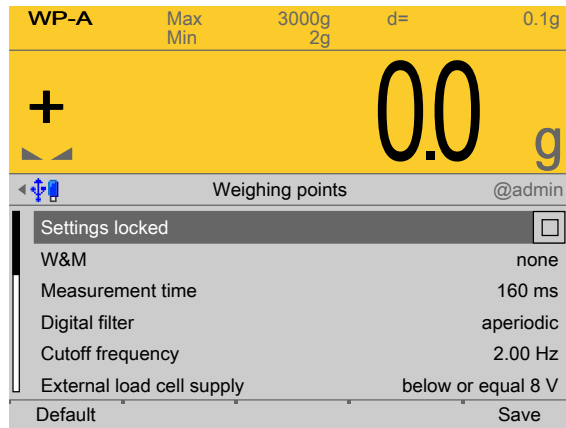

2. Select and confirm the individual parameters.

[Settings locked]

The weighing point settings and assignment can only be viewed as if the corresponding CAL switch were closed; see Chapter [2.7.1](#).

[W&M]

Setting for operation in legal metrology.

Selection: [None], OIML, NTEP (for USA) or NSC (for Australia)

For description and settings, refer to Chapter [4.7.1.1.1](#)

[Measurement time]

The duration of a measurement can be selected.

Selection: 5 ms, 10 ms, 20 ms, 40 ms, 80 ms, 160 ms, 320 ms, 640 ms, 960 ms, 1280 ms, 1600 ms, ≤ 1 s

A measurement time of ≤ 1 s must be selected for use in legal metrology.

[Digital filter]

The following includes examples of interference signals for the different filter types:

- **Bessel filter**

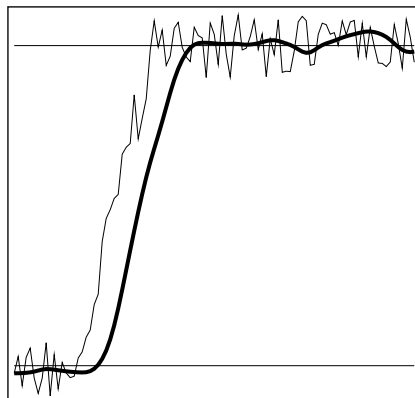

- **Aperiodic filter**

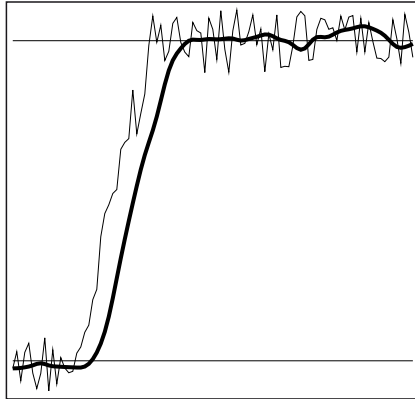

- **Butterworth filter**

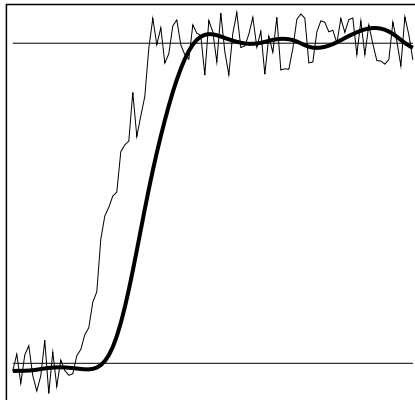

- **Tschebyscheff filter**

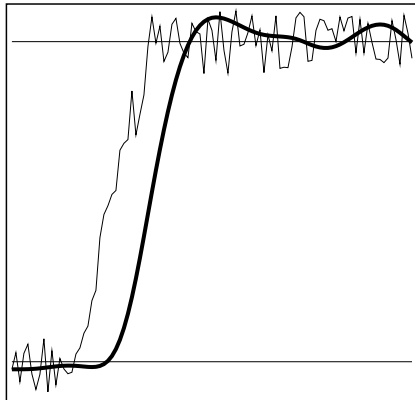

A digital filter can be switched on only with the measurement time set to ≤ 160 ms

Selection: no filter, Bessel, aperiodic, Butterworth, Tschebyscheff.

If no particularly frequent fluctuations are expected in ongoing operation, the following settings are recommended:

- [Measurement time]: ≤ 160 ms
- [Digital filter]: aperiodic
- [Cutoff frequency]: 2.00 Hz

[Cutoff frequency]

The smaller the cutoff frequency, the slower the measurement and the more stable the measurement result.

The cutoff frequency for the low pass filter can be selected. The permitted range is: 0.01...40.00 Hz.

The available options depend on the measurement time.

The menu line [Cutoff frequency] only appears if the digital filter is switched on.

[External load cell supply]

The external supply voltage is selected.

Selection: below or equal 8 V, above 8 V

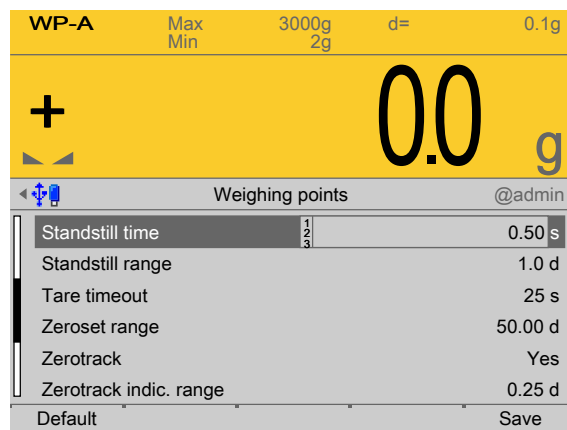
**[Standstill time]**

The parameters [Standstill time] and [Standstill range] are used to define the standstill of the scale (stable balance).

The [Standstill time] parameter is entered in seconds. The permitted range is: 0.00...2 s.

The time can be entered from 0.00 to 2.00 seconds, but always makes up at least one measurement time.

[Standstill range]

As long as the weight fluctuations remain within this range, the device is determined to be stable.

The [Standstill range] parameter is entered in "d". The permitted range is: 0.01...10.00 d.

For use in legal metrology, ≤ 1 d must be selected.

[Tare timeout]

Timeout for a tare/zeroset command that cannot be executed (e.g. due to mechanical instability of the scale, incorrect filter setting, resolution too high, standstill condition too strict).

This parameter is given in seconds. The permitted range is: 0.0...[2.5]...25 s.

At 0.0 s taring is only carried out when the scale is already stable.

[Zerose range]

Determine a \pm range around the zero point determined by the dead load during calibration; within this range

- the displayed gross weight can be set to zero by pressing the zero-setting key (or by a corresponding external command), and
- automatic zero tracking is active.

Setting range: 0.00...10000.00 d

For use in legal metrology a value $\leq 2\%$ of the max must be entered, example: 60 d for 3000 e of Class III.

[Zero track]

The zero display is automatically maintained within set limits.

Selection: No/Yes

When [No] is selected, the next three parameters are not shown.

When [Yes] is selected, values for the next three parameters must be entered.

[Zero track indic. range]

Indication range within which automatic zero track compensates for deviations.

Setting range: 0.25...10000.00 d

For use in legal metrology a value of < 0.5 d must be entered.

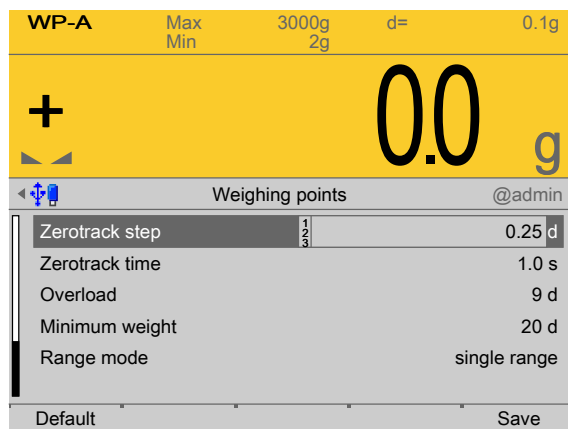
**[Zero track step]**

If a weight change exceeds the adjusted value, automatic tracking does not function any more.

Setting range for automatic tracking increments: 0.25...10 d

For use in legal metrology a value of ≤ 0.5 d must be entered.

[Zero track time]

Time interval for automatic zero track.

Setting range: 0.1...25 s

For use in legal metrology a value of 1 s must be entered.

[Overload]

Weighing range above the maximum capacity (Max) without error message.

Setting range: 0...9999999 d

For use in legal metrology a value of max. 9 d = e must be set.

[Min. weight]

Minimum weight at which a print command can be triggered.

Setting range: 0...9999999 d

For use in legal metrology a value of at least 20 d must be set.

[Range mode]

Selection: single range, multi-range, multi-interval

For range selection for scales and settings, refer to Chapter [4.7.1.1.2](#) and [4.7.1.1.3](#)

[Default] soft key

Settings are reset to factory settings.

3. Press the [Save] soft key to save the settings.

4.7.1.1.1 W&M (use in legal metrology)

In this menu item (under **Parameters**), the parameters of the **Internal weighing point** weighing electronics are configured for use in legal metrology.

Accessible via **MENU** - [Operating] - [System setup] - [Weighing points] - [Weighing point x] - [Parameters] - [W&M].

The following parameters can be selected: [None], OIML, NTEP (for USA) or NSC (for Australia)

	[None]	[OIML]	[NTEP]	[NSC]
Gross weight display	B	B	G	G
Recommended	0.2 mV/V @	0.2 mV/V @	0.2 mV/V @	0.2 mV/V @
min. measurement sig- nals	30,000 d	3000 e	3000 e	3000 e
	0.4 mV/V @	0.4 mV/V @	0.4 mV/V @	0.4 mV/V @
	60,000 d	6000 e	6000 e	6000 e

If legal-for-trade mode is switched on, the parameter settings (zerotrack etc.) must be selected accordingly. The device does not perform a check of this.

A unique check number is created every time a calibration or changed parameters are saved. This can be viewed in the menu [Operating] - [System information] - [Show calibration check numbers] (see Chapter [5.7](#)) and may also be written on the W&M label.

See also Chapter [4.7.1.2](#).

4.7.1.1.2 Range mode: Multi-range

In this menu item (under **Parameters**), a multi-range scale (of Class III or single-range scale of Class I and II with variable scale interval) of the **Internal weighing point** weighing electronics is configured

The multi-range scale is a scale with two or more weighing ranges with different maximum capacities and scale intervals. There is only one load receptor, with each range covering zero to its maximum capacity.

When [Range mode] = [Multi-range], the scale has up to three ranges with different resolution.

The weight display header includes the current range (R1, R2, and R3), Max, Min, and d (or e with devices used in legal metrology) (example: multi-range scale in range R2):

WP-A	R2	Max	2000kg	d=	
		Min	40kg	e=	2kg

The [Range limit 1] and [Range limit 2] switch points are the range limits. As soon as the gross weight exceeds range 1, the next highest range with the next highest scale interval becomes valid (1, 2, 5, 10, 20, 50). When reducing the weight, the scale interval of the previous range is kept. When the gross weight is $< 0.25 d$ of range 1, the scale is stable and not tared, the scale returns to range 1 with the corresponding scale interval.

Note:

During calibration, the multiple range function is always switched off.

Example:

Range mode: Multi-range

Range 1: 0...1000 g (when calibrating set scale interval: 0.1 g)

Range 2: 0...2000 g (next highest scale interval: 0.2 g)

Range 3: 0...3000 g (next highest scale interval: 0.5 g)

Accessible via **MENU** - [Operating] - [System setup] - [Weighing points] - [Weighing point x] - [Parameters] - [Range mode] - [Multi-range] .

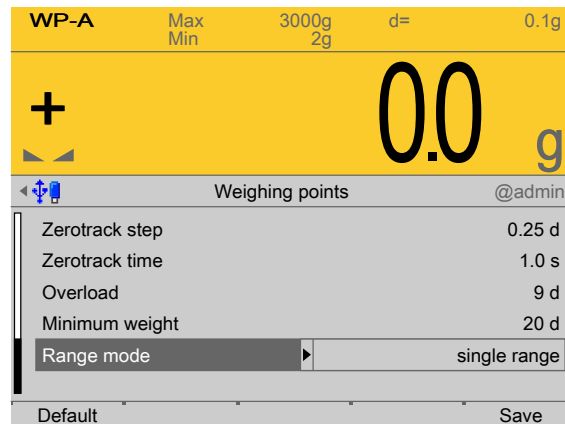

1. Select and confirm [Range mode].
 - ▷ A selection window opens.

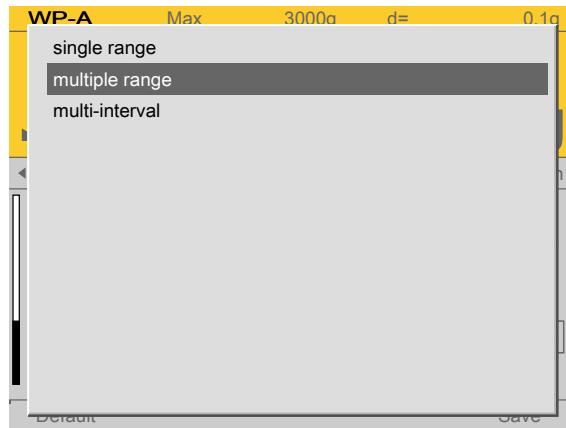

2. Select and confirm [Multiple range].

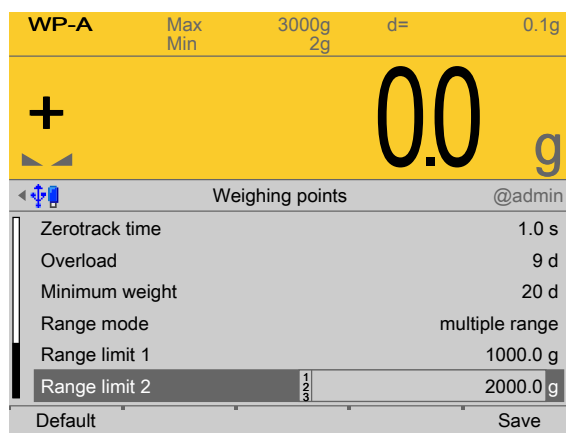

3. Configure switch point from range 1 to 2: enter 1000.0 g for [Range limit 1]
4. Configure switch point from range 2 to 3: enter 2000.0 g for [Range limit 2]
5. Press the [Save] soft key to save the settings.

4.7.1.1.3 Range mode: Multi-interval scale

In this menu item (under **Parameters**), a multi-interval scale (of Class III or single-range scale of Class I and II with variable scale interval) of the **Internal weighing point** weighing electronics is configured

The multi-interval scale is a scale with a weighing range that is divided into intervals. Each interval range has a different scale interval, where the weighing range is automatically switched depending on the load on the scale and also when the load is placed on/ removed from the scale.

When [Range mode] = [Multi-interval], the scale has up to three ranges with different resolution.

The weight display header includes the current interval range (R1, R2, or R3), Max, Min, and d (or e with devices used in legal metrology) (Example: multi-interval scale in range R2):



The parameters [Range limit 1] and [Range limit 2] are the interval ranges. As soon as the displayed weight exceeds range 1, the next highest range with the next highest scale interval becomes valid (1, 2, 5, 10, 20, 50).

Note:

During calibration, the multi-interval function is always switched off.

Example:

Range mode: Multi-interval

Interval range 1: 0...1500 g (when calibrating set scale interval: 0.1 g)

Interval range 2: 1500...2900 g (next highest scale interval: 0.2 g)

Accessible via **MENU** - [Operating] - [System setup] - [Weighing points] - [Weighing point x] - [Parameters] - [Range mode] - [Multi-interval scale] .

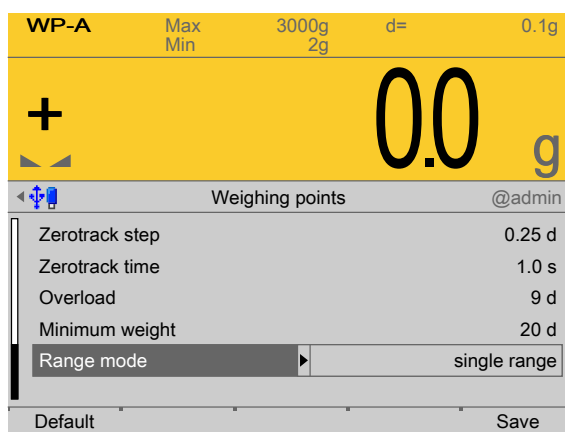

1. Select and confirm [Range mode].

▷ A selection window opens.

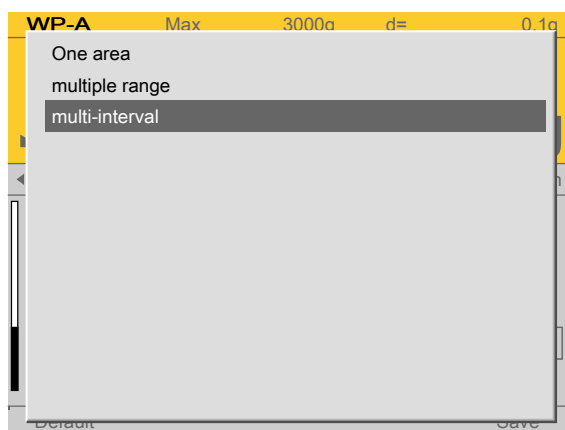

2. Select and confirm [Multi-interval].

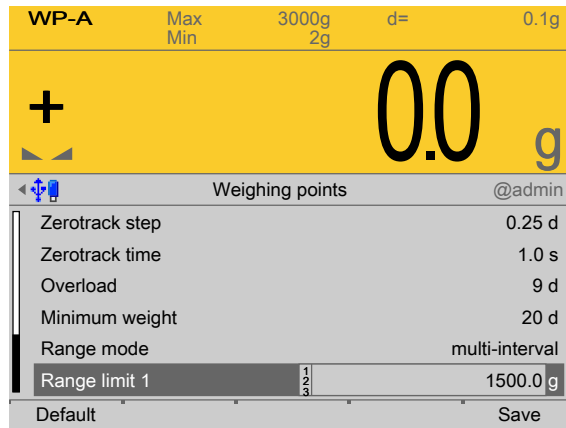

3. Configure interval range 1: enter 1500.0 g for [Range limit 1].
4. Configure interval range 2: enter 2900.0 g for [Range limit 2].
5. Press the [Save] soft key to save the settings.

4.7.1.2 Calib

In this menu item, the **Internal weighing point** weighing electronics are calibrated.

- [New], see Chapter [4.7.1.2.1](#).
 - [Max] (maximum capacity), see Chapter [4.7.1.2.1.1](#).
 - [Scale interval], see Chapter [4.7.1.2.1.2](#).
 - [Dead load at], see Chapter [4.7.1.2.1.3](#) and, if **correction** is necessary, see also Chapter [4.7.1.2.3](#).
 - [Max at], see Chapter [4.7.1.2.1.4](#).
- [Modify] (for small changes only), see Chapter [4.7.1.2.2](#).
 - [Max] (maximum capacity), see Chapter [4.7.1.2.1.1](#).
 - [Scale interval], see Chapter [4.7.1.2.1.2](#).
 - [Dead load at], see Chapter [4.7.1.2.1.3](#) and, if **correction** is necessary, see also Chapter [4.7.1.2.3](#).
 - [Max at], see Chapter [4.7.1.2.1.4](#).
- [Dead load at] (correction), see Chapter [4.7.1.2.3](#).

Note:

The [Modify] menu item is only used for small changes (e.g. changing the dead load/preload, changing the mV/V values for dead load/preload and/or Max, changing the scale interval).

Usually, the [New] menu item should be selected.

With applications for use in legal metrology, the legal requirements and the conditions given on the test/approval certificate must be taken into account when selecting the settings.

There are two ways to save the calibration data:

- **CAL switch**

The calibration data can be protected with CAL switch A/B and the weighing electronics with CAL switch 1 (see Chapter 2.7.1), which must be sealed in the "secure" position for use in legal metrology.

Note:

The CAL switches A/B are only accessible after dismantling the rear panel.

- **Software**

A unique check number is created every time a calibration or changed parameters are saved. This can be viewed in the menu [Operating] - [System information] - [Show calibration check numbers] (see Chapter 5.7) and may also be written on the W&M label.

Before calibration the weighing point must be assigned, see Chapter 4.7.

During calibration, the device must be set to gross weight display (reset tare, if necessary).

Accessible via **MENU** - [Operating] - [System setup] - [Weighing points] - [Weighing point x] - [Calib] .

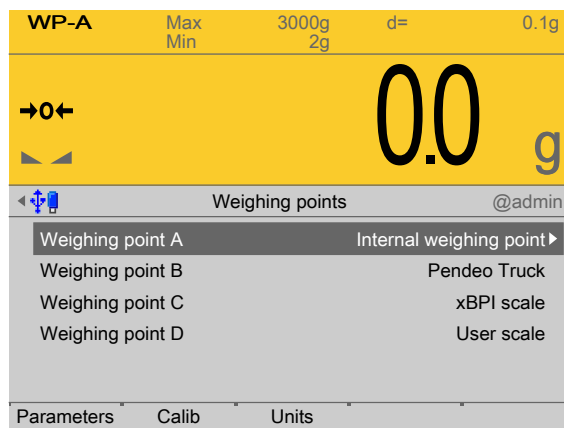

► In this case: Select [Weighing point A] with [Internal weighing point] and press the [Calib] soft key.

▷ The data from the last calibration is displayed.

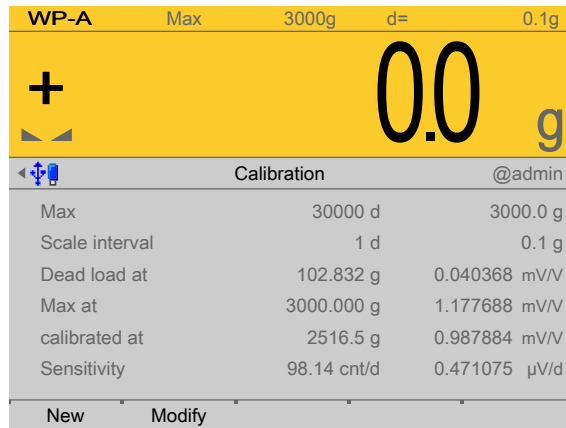

- The [New] soft key starts a new calibration, see Chapter [4.7.1.2.1](#).
- The [Modify] soft key (only use for small changes!) changes an existing calibration, see Chapter [4.7.1.2.2](#).

4.7.1.2.1 New

In this menu item, a new **calibration** of the **Internal weighing point** weighing electronics is conducted and configured.

The descriptions and settings of [Max], [Scale interval], [Dead load at] and [Max at] are described in the following chapters:

- [Max] (maximum capacity), see Chapter [4.7.1.2.1.1](#).
- [Scale interval], see Chapter [4.7.1.2.1.2](#).
- [Dead load at], see Chapter [4.7.1.2.1.3](#) and, if **correction** is necessary, see also Chapter [4.7.1.2.3](#).
- [Max at], see Chapter [4.7.1.2.1.4](#).

Accessible via **MENU** - [Operating] - [System setup] - [Weighing points] - [Weighing point x] - [Calib] - [New] .

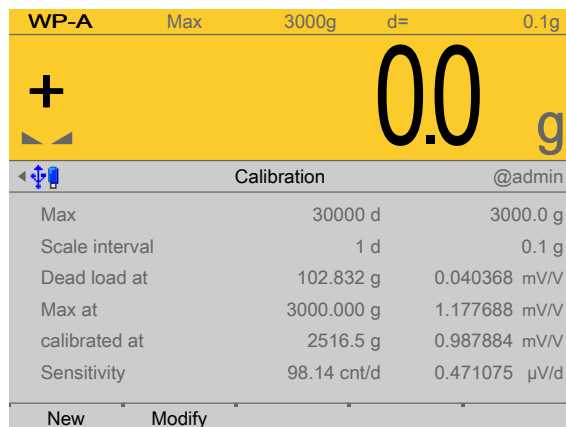

The data from the last calibration is displayed.

1. Press the [New] soft key.

When [New] is pressed, the default settings are restored and calibration is then started.

- ▷ A window with a prompt is displayed.

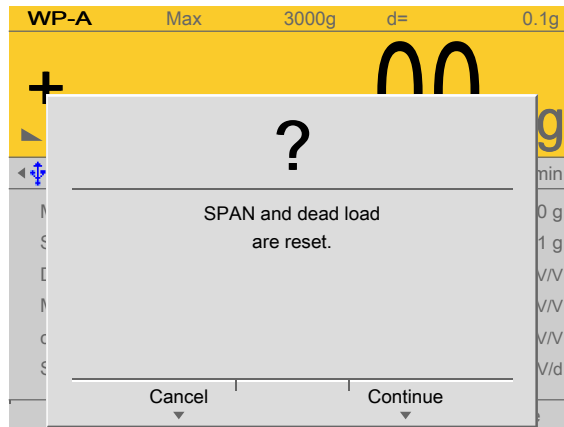

2. Press the [Continue] soft key. The factory settings are set.
Press the [Cancel] soft key to cancel the selection.

- ▷ A selection window opens.

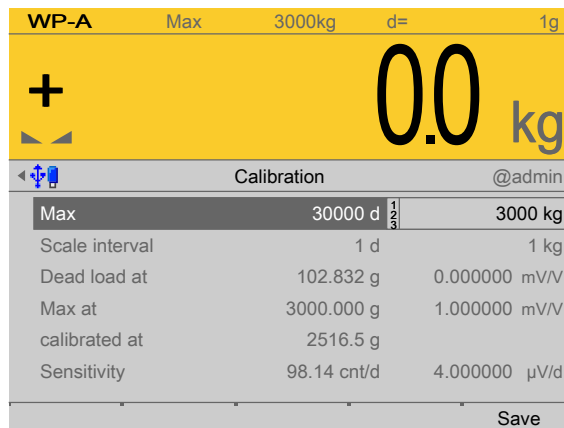

3. Configure and confirm the parameters in the prescribed order.

[Max] (maximum capacity)

The maximum capacity that can be measured without a dead load.

For description and settings, refer to Chapter [4.7.1.2.1.1](#).

[Scale interval]

The scale interval (d) is the difference between two successive display values.

For description and settings, refer to Chapter [4.7.1.2.1.2](#).

[Dead load at]

Use an empty scale or vessel as the dead load (normal case).

For description and settings, refer to Chapter [4.7.1.2.1.3](#).

[Max at]

Perform calibration with weights, without weight (by mV/V values or data), or linearization, see Chapter [4.7.1.2.1.4](#).

- [by load], see Chapter [4.7.1.2.1.4.1](#).
- [by mV/V], see Chapter [4.7.1.2.1.4.2](#).

- [by data] Load cell data (smart calibration), see Chapter [4.7.1.2.1.4.3](#).
- [Linear.] (linearization), see Chapter [4.7.1.2.1.4.4](#).

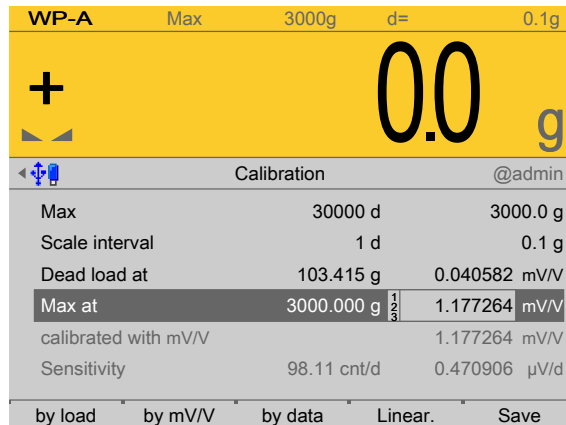

4. Press the [Save] soft key to save the calibration.

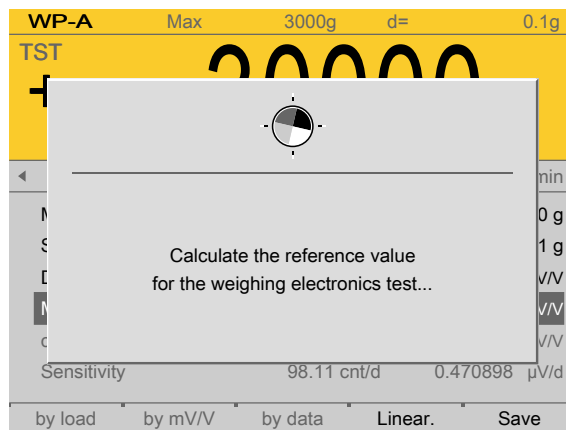

This window appears briefly.

The maximum capacity (Max) is displayed with the ID "TST" and without a weight unit.

The confirmation is displayed as follows: "saving calibration..."

Note:

After exiting calibration, go to the menu [Param] and set the parameter [Settings locked] to activate overwrite protection via the software (see Chapter [2.7.2](#)).

Note:

A unique check number is created every time a calibration or changed parameters are saved. This can be viewed in the menu [Operating] - [System information] - [Show calibration check numbers] (see Chapter [5.7](#)) and may also be written on the W&M label.

To save an application for use in legal metrology, see Chapter [4.7.1.2](#).

5. Cancel the calibration using the **EXIT** key.
 - ▷ A prompt is shown.

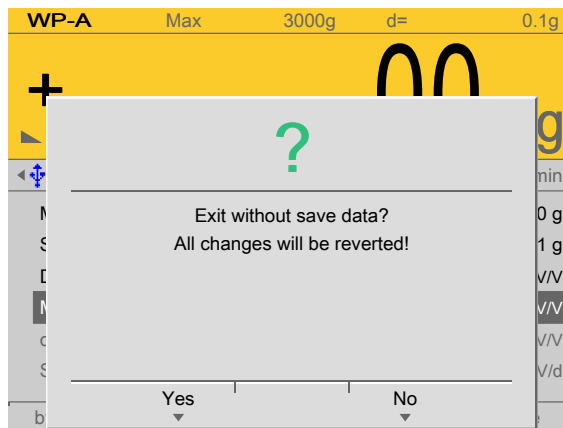

Press the [Yes] soft key to exit calibration without saving.

Calibration is finished without saving with the following display: "undoing calibration...".

4.7.1.2.1.1 Max (maximum capacity)

In this menu item (under **New/Modify**), the maximum weight is defined when calibrating the **Internal weighing point** weighing electronics.

The maximum capacity (Max) determines the maximum weight without dead load of the weight to be measured and the displayed number of digits behind the decimal point. Normally, Max is less than the load cell capacity (max. capacity of load cell x number of load cells).

Permissible values for the maximum capacity are: Max weight value from 0.00010 to 999999 in mg, g, kg, t, lb or oz.

Maximum weight value must be an integer multiple of the scale interval (1 d). It may have up to 6 digits and is entered as a numeric value with or without a decimal point.

Accessible via **MENU** - [Operating] - [System setup] - [Weighing points] - [Weighing point x] - [Calib] - [New/Modify] - [Max] .

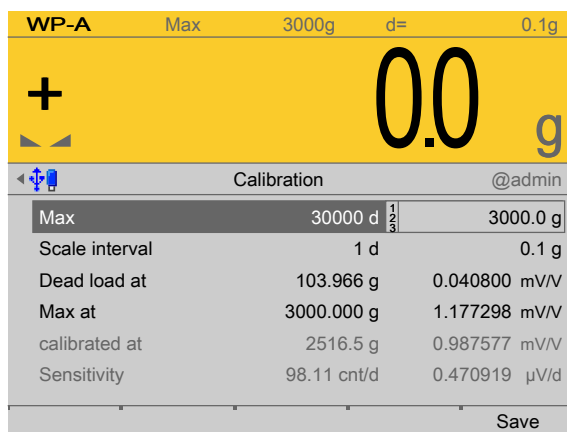

For new calibrations, the parameters [Scale interval], [Dead load at] and [Max at] are inactive.

1. Select [Max] and activate the input field.
2. Enter the value with decimal places (in this example: 3000.0).
3. Press the  key to select the weight unit.
4. Confirm the entries.

- ▷ The confirmation is displayed with "setting Max...".

Note:

If a linearization was carried out (see Chapter [4.7.1.2.1.4.4](#)), the following message appears once the parameter has been selected: "Cannot be changed while linearization is active."

Only deleting of the linearization points deactivates the linearization mode!

5. Press the [Save] soft key to save the calibration.

[Save] is deactivated for new calibrations. The next menu item [Scale interval] is activated.

- ▷ The reference value is calculated for the electronics test.

Possible error messages, see Chapter [9.7.1](#).

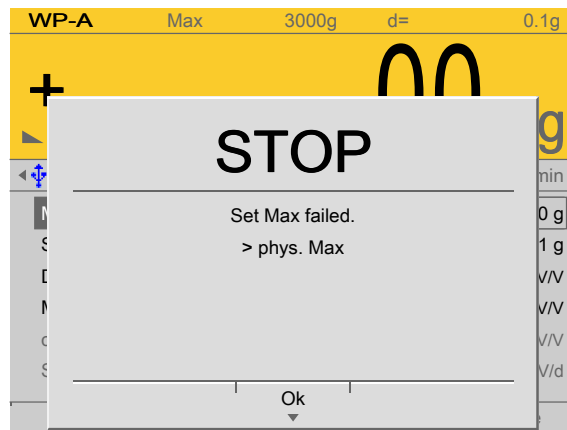

If [OK] is pressed, the input value for the maximum capacity is canceled.

4.7.1.2.1.2 Scale interval

In this menu item (under **New/Modify**), the scale interval (d) is defined when calibrating the **Internal weighing point** weighing electronics.

The scale interval (d) is the difference between two successive display values.

With a scale used in legal metrology, this value is called the verification scale interval (e), which corresponds to the scale interval: $d = e$.

Example:

- Max = 6000 kg, scale interval (1 d) = 2 kg
- Calculation for scale interval for Max (automatic):
- $d = \text{Max} / \text{scale interval (1 d)}$
- $d = 6000 \text{ kg} / 2 \text{ kg}$
- $d = 3000$

Accessible via **MENU** - [Operating] - [System setup] - [Weighing points] - [Weighing point x] - [Calib] - [New/Modify] - [Scale interval] .

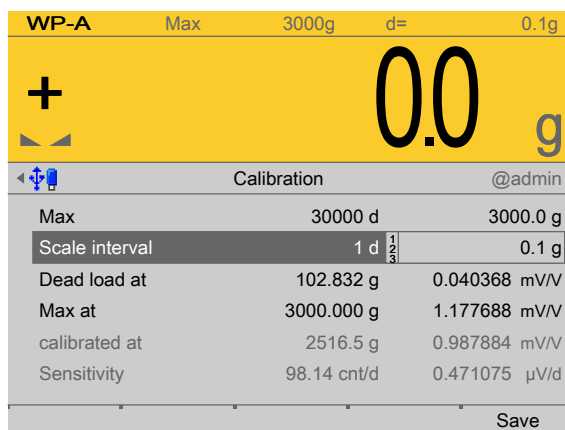

For new calibrations, the parameters [Dead load at] and [Max at] are inactive.

The weight unit is taken from [Max]. The number of digits behind the decimal point is also automatically determined when [Max] is entered.

1. Select [Scale interval] (1 d) and activate the input field.
 - ▷ A selection window opens.

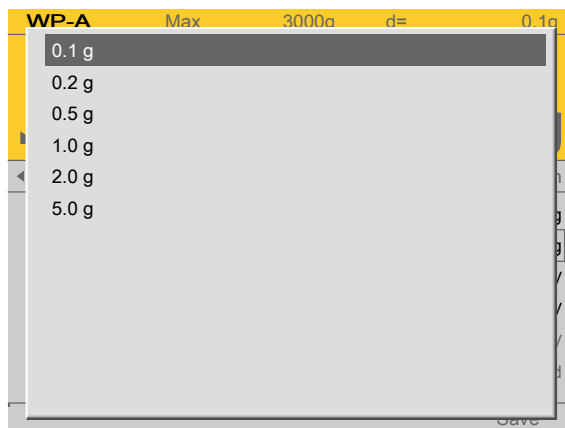

2. Select and confirm the desired value.

- ▷ The confirmation is displayed with "setting scale interval..."

The scale interval (d) is calculated, based on the maximum weight value.

3. Press the [Save] soft key to save the calibration.

[Save] is deactivated for new calibrations. The next menu item [Dead load at] is activated.

Possible error messages, see Chapter 9.7.2.



This message appears if the maximum capacity [Max] of the scale range is not an integer multiple of the scale interval.

Press [OK] to cancel the setting.

4.7.1.2.1.3 Dead load at

In this menu item (under **New/Modify**), the dead load (empty scale or vessel) is defined when calibrating the **Internal weighing point** weighing electronics.

Note:

If a linearization was carried out (see Chapter 4.7.1.2.1.4.4), the following message appears once the parameter has been selected: "Cannot be changed while linearization is active."

Only deleting of the linearization points deactivates the linearization mode!

Accessible via **MENU** - [Operating] - [System setup] - [Weighing points] - [Weighing point x] - [Calib] - [New/Modify] - [Dead load at] .

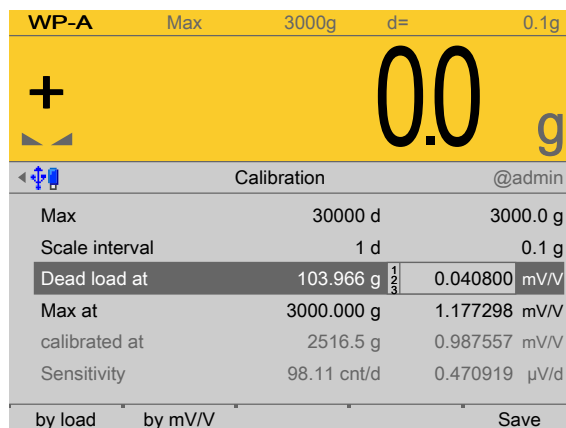

To use the empty scale or vessel as dead load (normal case):

1. **Empty** the scale or vessel.
 2. Press the [By load] soft key.
 3. Confirm the entries.
 - ▷ The confirmation is displayed with "Setting dead load..."

If the mV/V value of the dead load was calculated, or if it is known from the previous calibration, the value can be overwritten by pressing the [by mV/V] soft key.
 4. Press the [Save] soft key to save the calibration.
- [Save] is deactivated for new calibrations.

Possible error messages, see Chapter [9.7.3](#).

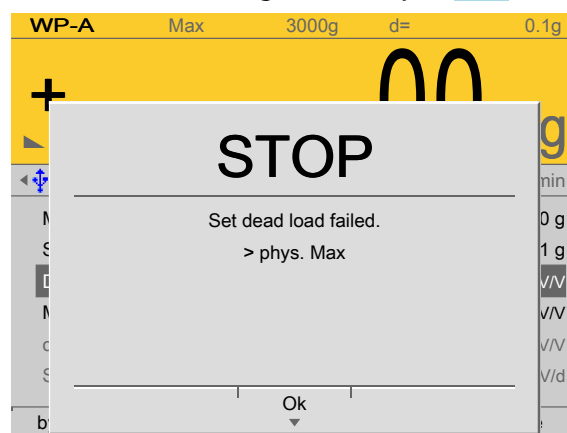

This message is displayed when the dead load entered in mV/V plus scale interval in mV/V is higher than 3 mV/V (= 36 mV).

Press [OK] to cancel the setting.

4.7.1.2.1.4 Max at

In this menu item (under **New/Modify**), calibration of the **Internal weighing point** weighing electronics is conducted and configured with or without weights (by mV/V values or data) or linearization is performed and configured.

- [by load], see Chapter [4.7.1.2.1.4.1](#).
- [by mV/V], see Chapter [4.7.1.2.1.4.2](#).
- [by data] Load cell data (smart calibration), see Chapter [4.7.1.2.1.4.3](#).
- [Linear.] (linearization), see Chapter [4.7.1.2.1.4.4](#).

Accessible via **MENU** - [Operating] - [System setup] - [Weighing points] - [Weighing point x] - [Calib] - [New/Modify] - [Max at] .

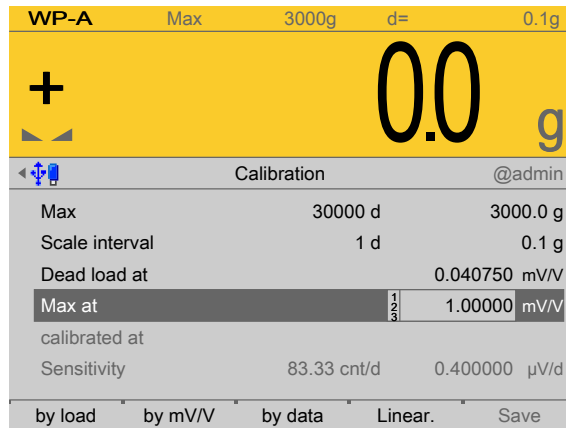

- ▶ Select [Max at] and press the corresponding soft key.

[by load] soft key

Calibrating with weights, see Chapter [4.7.1.2.1.4.1](#).

[by mV/V] soft key

Calibrating with mV/V values, see Chapter [4.7.1.2.1.4.2](#).

[by data] soft key

Calibrating with load cell data (smart calibration), see Chapter [4.7.1.2.1.4.3](#).

[Linear.] soft key

Calibrating with linearization points, see Chapter [4.7.1.2.1.4.4](#).

4.7.1.2.1.4.1 by load

In this menu item (under **Max at**), **calibration** of the **Internal weighing point** weighing electronics is performed with weights.

Accessible via **MENU** - [Operating] - [System setup] - [Weighing points] - [Weighing point x] - [Calib] - [New] - [Max at] - [by load] .

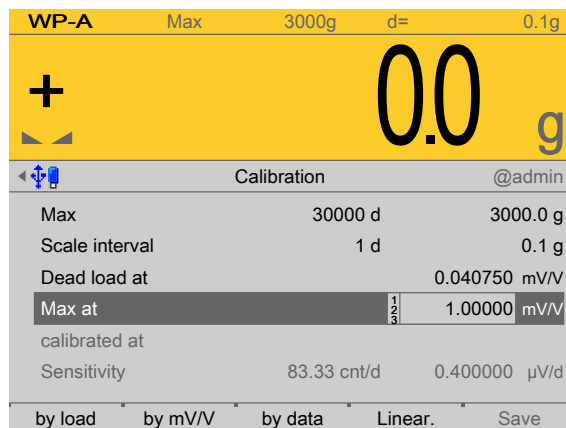

1. Select [Max at] and press the [by load] soft key.
 - ▷ An input window opens.

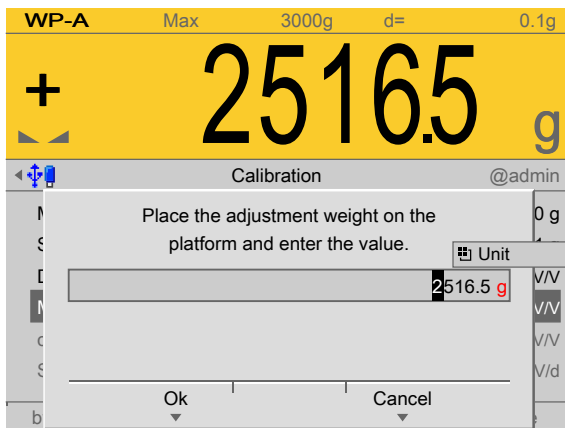

2. Place calibration weight on the scale and enter the value.

The weight unit for the calibration weight (press  to change) may differ from the unit in the device; conversion is automatic.

3. Press the [OK] soft key
 - ▷ The confirmation is displayed with "setting SPAN by load...".

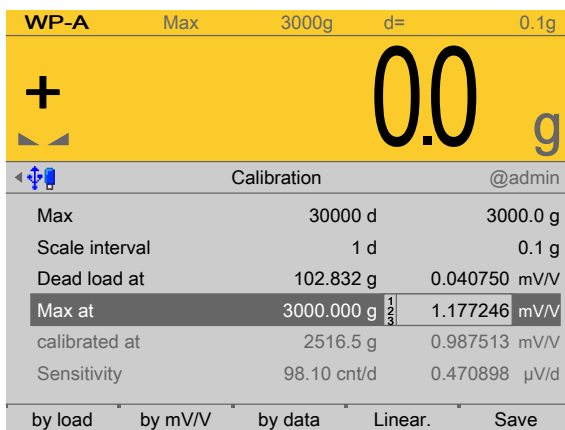

The weight value of the calibration weight, weight unit, and measuring signal in mV/V corresponding to this value are displayed in the [calibrated at] line.

4. Press the [Save] soft key to save the calibration.

Possible error messages, see Chapter 9.7.4.

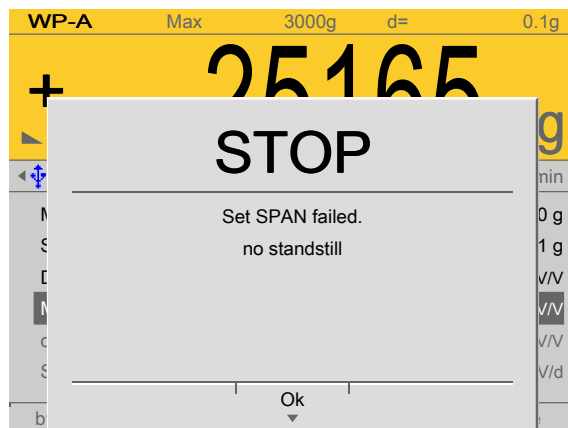

Press [OK] to cancel the setting.

4.7.1.2.1.4.2 by mV/V

In this menu item (under **Max at**), **calibration** of the **Internal weighing point** weighing electronics is performed with mV/V values.

During input of the load cell mV/V value, the acceleration of gravity at the place of installation can be taken into account. The STAR load cell data is based on the acceleration of gravity in Hamburg, Germany: 9.81379 m/s^2 .

Calculating SPAN

SPAN indicates the equivalent input voltage in mV/V related to the maximum capacity (Max) of the scale. It is calculated as follows:

$\text{SPAN [mV/V]} = \text{maximum capacity} \times \text{load cell sensitivity } C_n \text{ [mV/V]} / \text{load cell capacity (maximum capacity } E_{\text{max}} \times \text{number of load cells)}$

load cell sensitivity $C_n = \text{rated output } C_n$ (see technical data for the load cell)

Calculate dead load

The input voltage in mV/V equivalent to the dead load can be calculated by using the dead load rather than the maximum capacity in the formula specified above.

Normally, calculation of the dead load (scale without load or empty vessel) is not necessary.

Subsequent dead load correction (see Chapter [4.7.1.2.3](#)) can be used for later re-determination of the dead load, when the scale or vessel is empty.

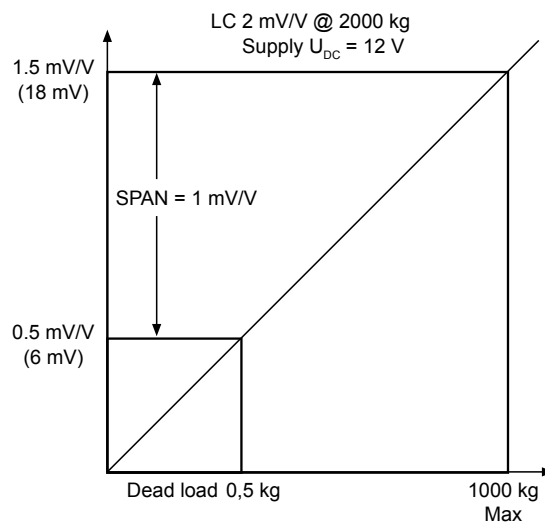

Example

- 1 load cell with rated output $C_n = 2 \text{ mV/V}$
- At maximum capacity 2000 kg
- Maximum capacity 1000 kg
- Dead load 500 kg
- Load cell supply voltage $U_{DC} = 12 \text{ V}$

Accessible via **MENU** - [Operating] - [System setup] - [Weighing points] - [Weighing point x] - [Calib] - [New] - [Max at] - [by mV/V] .

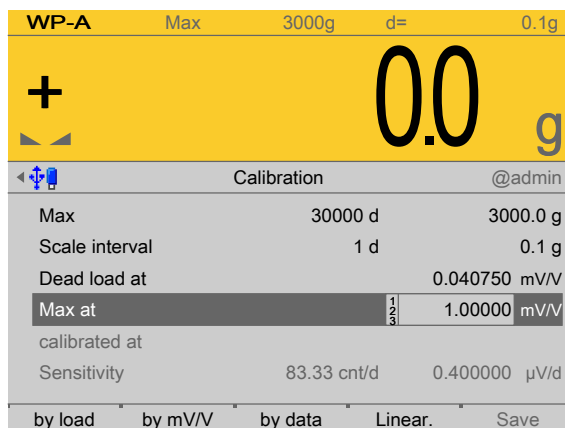

1. Select [Max at] and press the [by mV/V] soft key.
 ▷ An input window opens.

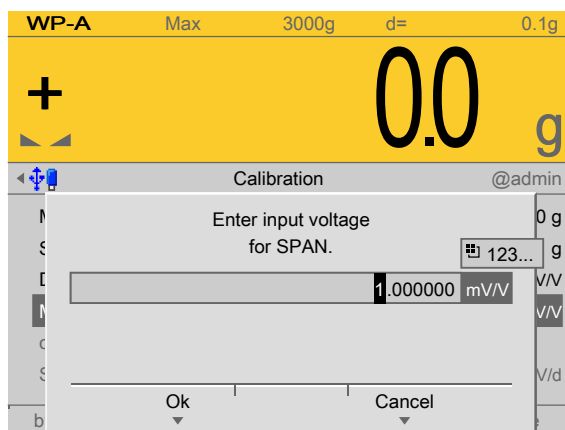

2. Enter input voltage for SPAN.
 If necessary, enter the value for the subsequent dead load correction (see Chapter 4.7.1.2.3).
3. Press the [OK] soft key.
4. Press the [Save] soft key to save the calibration.

4.7.1.2.1.4.3 by data

In this menu item (under **Max at**), **calibration** of the **Internal weighing point** weighing electronics is performed with load cell data (smart calibration).

If the scale is not used in legal metrology, calibration without weights can be performed. The easiest method is the one using load cell data without calculation.

Accessible via **MENU** - [Operating] - [System setup] - [Weighing points] - [Weighing point x] - [Calib] - [New] - [Max at] - [by data] .

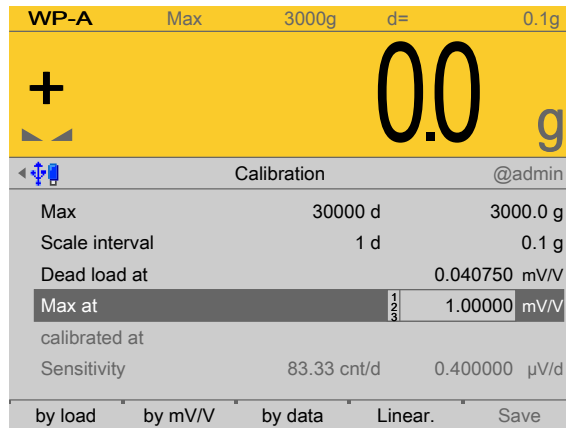

1. Select [Max at] and press the [by data] soft key.
▷ A selection window opens.

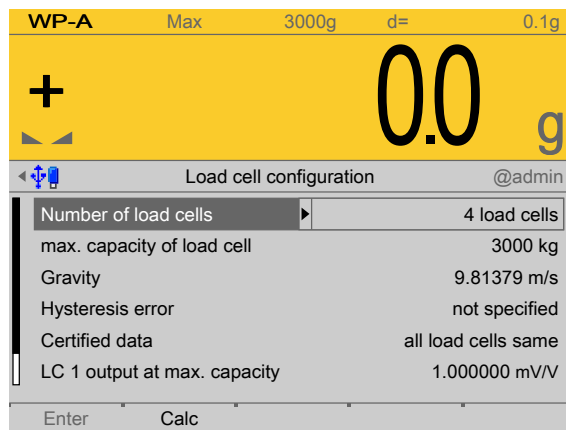

2. Select and confirm the individual parameters.

[Number of load cells]

Number of load cells connected in parallel (1, 2...[4]...9, 10)

Take the next values from the technical data of the load cells.

[max. capacity of load cell]

Maximum capacity E_{\max} of a load cell (not the total maximum capacity of the scale!)

[Gravity]

Gravity at the place of installation; default is the value for Hamburg, Germany:
9.81379 m/s².

[Hysteresis error]

Selection: not specified, specified

If [not specified] is switched to [specified], values for [Correction A] and [Correction B] must be entered. For the calibration certificate values of the load cell, please refer to "Hysteresis correction values for Smart Calibration".

[Certified data], [LC output at max. capacity], [LC output impedance]

LC = load cell

Selection: all load cells same, each load cell specific

For [each load cell specific], press the [Enter] soft key to enter individual data for each load cell.

When [all load cells same] is set, only one value each must be entered for [LC output at max. capacity] and [LC output impedance]. For the calibration certificate values of the load cell, please refer to "Output at max. capacity" and "Output impedance".

3. Press the [Calc] soft key to start the calculation.
4. Confirm the calculation to save the calculated mV/V value to the calibration data.
5. Press the [Save] soft key to save the calibration.

4.7.1.2.1.4.4 Linearization

In this menu item (under **Max at**), **calibration** of the **Internal weighing point** weighing electronics is performed with linearization points.

The measurement range for a straight can be optimized by setting the linearization points.

Prerequisite

- Calibration of Max and dead load was done.

Accessible via **MENU** - [Operating] - [System setup] - [Weighing points] - [Weighing point x] - [Calib] - [New] - [Max at] - [Linear.] .

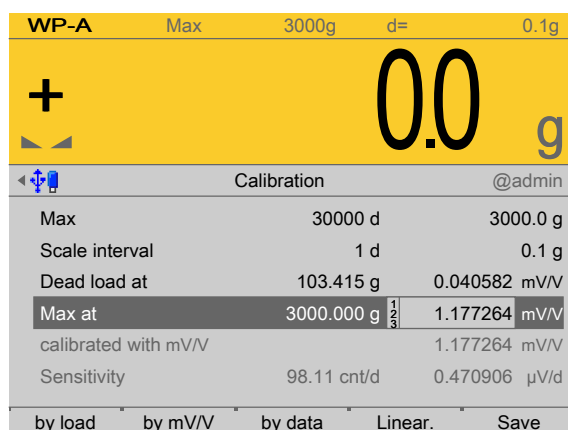

1. Select [Max at] and press the [Linear.] soft key.
 - ▷ The linearization menu opens.

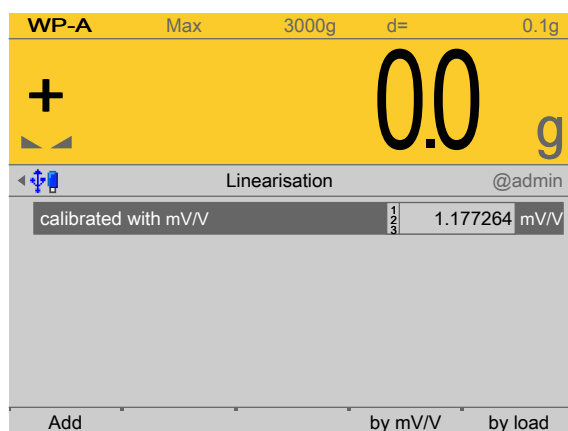

2. Press the [Add] soft key to set a linearization point.
 - ▷ An input window opens.

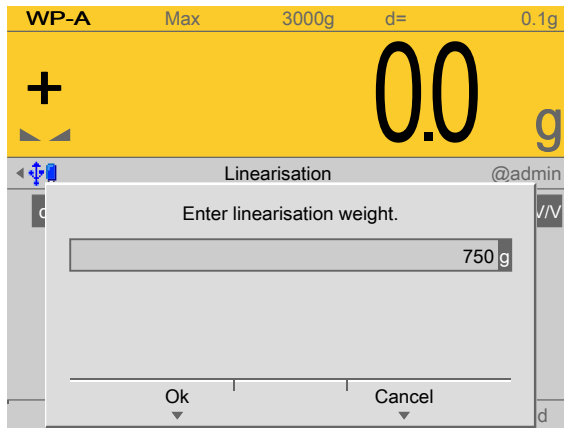

3. Enter the desired value using the keyboard.
4. Press the [OK] soft key.
5. Repeat these steps to set up to three linearization points in succession.

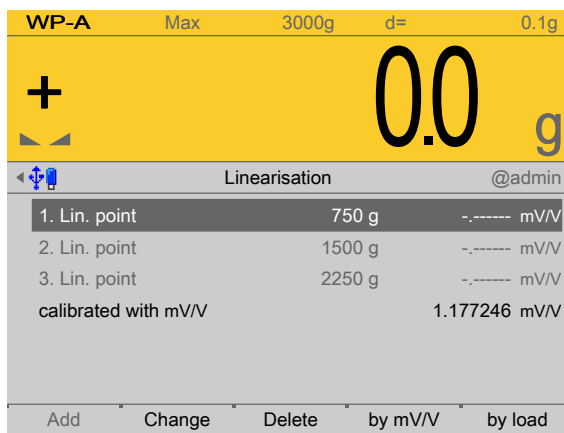

The window shows the set linearization points.

The [by mV/V] soft key can be used to enter the value directly.

The [Change] soft key can be used to modify the selected linearization point.

The [Delete] soft key can be used to delete the selected linearization point.

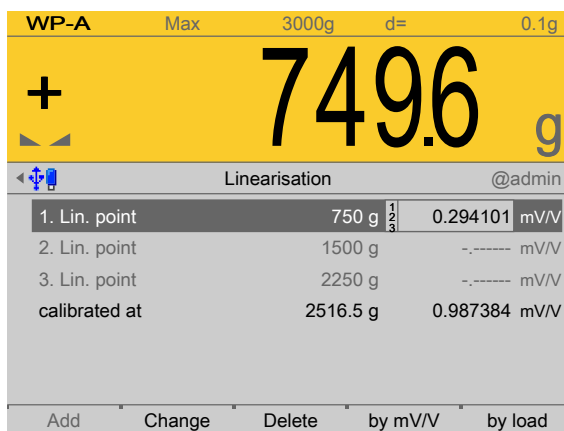

6. Select a linearization point, place the corresponding weight on the scale, and press the [by load] soft key.

▷ The value corresponding to the weight is automatically entered in mV/V.

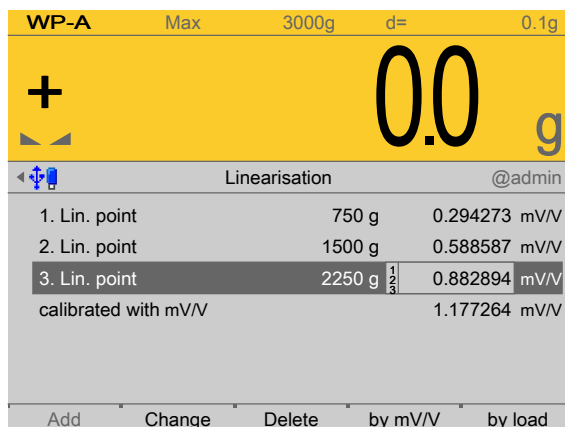

7. Repeat these steps to automatically enter the corresponding values for the weights of all set linearization points in mV/V.
8. Press the **EXIT** key to switch to the previous window.
 - ▷ A message is displayed, indicating that the value for Max cannot be changed as long as linearization is active.

Note:

Linearization is deactivated/deleted and all linearization points are deleted.

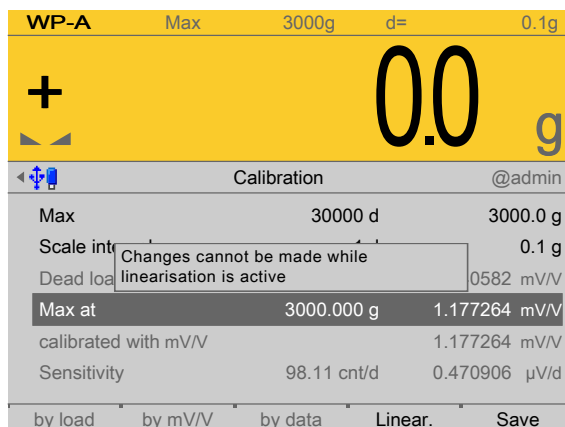

9. Press the [Save] soft key to save the calibration.

4.7.1.2.2 Modify

In this menu item (under **Calib**), small changes are made to an existing calibration of the **Internal weighing point** weighing electronics.

If e.g. the vessel or platform weight has changed, the dead load must be adjusted; see Chapter [4.7.1.2.3](#).

The descriptions and settings of [Max], [Scale interval], [Dead load at] and [Max at] are described under [Calib]- [New] :

- [Max] (maximum capacity), see Chapter [4.7.1.2.1.1](#).
- [Scale interval], see Chapter [4.7.1.2.1.2](#).
- [Dead load at], see Chapter [4.7.1.2.1.3](#) and, if **correction** is necessary, see also Chapter [4.7.1.2.3](#).

- [Max at], see Chapter [4.7.1.2.1.4](#).

Accessible via **MENU** - [Operating] - [System setup] - [Weighing points] - [Weighing point x] - [Calib] - [Modify] .

WP-A Max 3000g d= 0.1g		
+		0.0 g
Calibration @admin		
Max	30000 d	3000.0 g
Scale interval	1 d	0.1 g
Dead load at	102.832 g	0.040368 mV/V
Max at	3000.000 g	1.177688 mV/V
calibrated at	2516.5 g	0.987884 mV/V
Sensitivity	98.14 cnt/d	0.471075 μ V/d
New Modify		

The data from the last calibration is displayed.

1. Press the [Modify] soft key.
▷ A selection window opens.

WP-A Max 3000g d= 0.1g		
+		0.0 g
Calibration @admin		
Max	30000 d $\frac{1}{2}$	3000.0 g
Scale interval	1 d	0.1 g
Dead load at	103.966 g	0.040800 mV/V
Max at	3000.000 g	1.177298 mV/V
calibrated at	2516.5 g	0.987577 mV/V
Sensitivity	98.11 cnt/d	0.470919 μ V/d
Save		

2. Select and confirm the desired parameters.

[Max] (maximum capacity)

The maximum capacity that can be measured without a dead load.

For description and settings, refer to Chapter [4.7.1.2.1.1](#).

[Scale interval]

The scale interval (d) is the difference between two successive display values.

For description and settings, refer to Chapter [4.7.1.2.1.2](#).

[Dead load at]

Use an empty scale or vessel as the dead load (normal case).

For description and settings, refer to Chapter [4.7.1.2.1.3](#).

[Max at]

Perform calibration with weights, without weight (by mV/V values or data), or linearization, see Chapter [4.7.1.2.1.4](#).

- [by load], see Chapter [4.7.1.2.1.4.1](#).
- [by mV/V], see Chapter [4.7.1.2.1.4.2](#).
- [by data] Load cell data (smart calibration), see Chapter [4.7.1.2.1.4.3](#).
- [Linear.] (linearization), see Chapter [4.7.1.2.1.4.4](#).

3. Press the [Save] soft key to save the calibration.

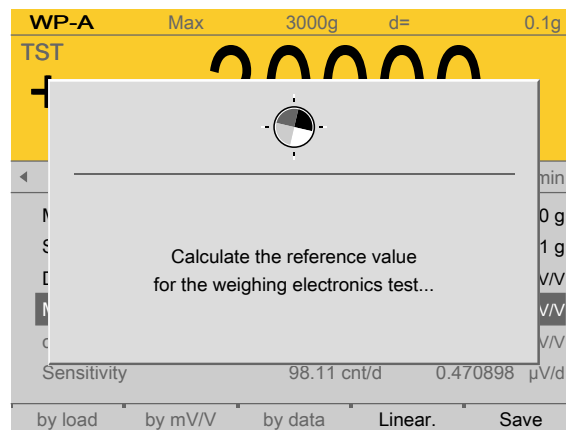

This window appears briefly.

The maximum capacity (Max) is displayed with the ID "TST" and without a weight unit.

The confirmation is displayed as follows: "saving calibration..."

Note:

After exiting calibration, go to the menu [Param] and set the parameter [Settings locked] to activate overwrite protection via the software (see Chapter [2.7.2](#)).

Note:

A unique check number is created every time a calibration or changed parameters are saved. This can be viewed in the menu [Operating] - [System information] - [Show calibration check numbers] (see Chapter [5.7](#)) and may also be written on the W&M label.

To save an application for use in legal metrology, see Chapter [4.7.1.2](#).

4.7.1.2.3 Dead load at (correction)

In this menu item, the dead load (empty scale or vessel) is redefined for an existing **calibration** of the **Internal weighing point** weighing electronics.

If the vessel/platform weight changes by an amount that is higher than the zero range; e.g. due to dead load reduction, dead load increase, or mechanical changes, the functions for automatic zero track and manual zero setting no longer work.

the range currently used by zero track or set zero is displayed in the menu [Operating]- [System information]- [HW options]- [WPx]- [Monitor] .



Press the  key to switch on increased resolution (10-fold) for the weight value.

If the full zeroset range is already being utilized, you can still correct the dead load (overwrite protection must be deactivated, see Chapter 2.7) without affecting the other calibration data/parameters.

To this end, calibration is performed in the menu [Operating] - [System setup] - [Weighing points] - [Weighing point x] - [Modify] - [Dead load at] - [By load] (see Chapter 4.7.1.2.1.3).

Note:

If a linearization was carried out (see Chapter 4.7.1.2.1.4.4), the following message appears once the parameter has been selected: "Cannot be changed while linearization is active."

Only deleting of the linearization points deactivates the linearization mode!

4.7.1.3 Units

In this menu item, additional weight units for the display and the display accuracy of the **Internal weighing point** weighing electronics are configured.

The device is calibrated with a selected weight unit. Up to two more units can also be displayed.

The weight display is switched using the function keys (F1 or F2). This must be assigned beforehand, see Chapter 4.3.

When three units are displayed, they are shown in the following sequence: from 1 to 2, 3, 1, 2, and so on.

If unit 2 or 3 is displayed, the symbol  (for non-legal weights) is also shown in addition to the weight unit on devices used for legal metrology.

In the following **example**,

- unit 2 is defined in [oz]. The display accuracy is set to [basic accuracy].

This means that the scale interval in weight roughly corresponds to the calibrated scale interval.

- Unit 3 in [lb] has a display accuracy that is one level higher, meaning that the scale interval is roughly one level smaller than the calibrated scale interval.

The values for Max and Min for the additional units are (roughly) calculated taking the associated scale intervals into account.

Accessible via **MENU** - [Operating] - [System setup] - [Weighing points] - [Weighing point x] - [Units] .

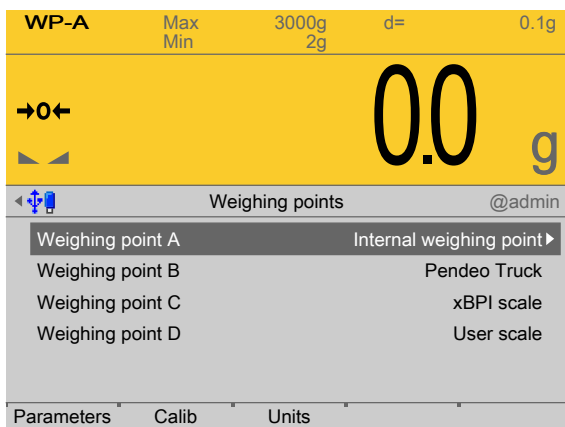

1. In this case: Select [Weighing point A] with [Internal weighing point] and press the [Units] soft key to select further units and the associated display accuracy. In this case: Select [Weighing point A] with [Internal weighing point] and press the [Units] soft key to select further units and the associated display accuracy.

▷ The following window opens:

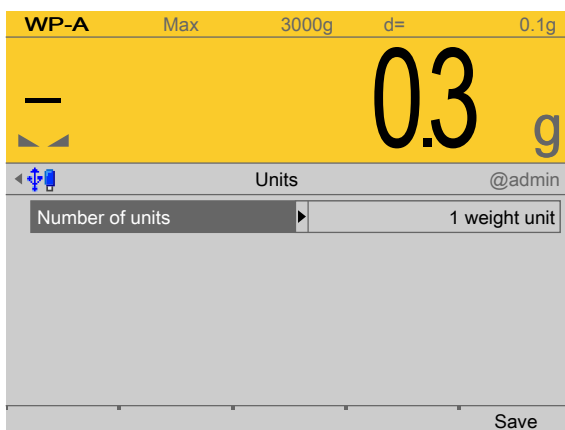

2. Confirm the selection.
 - ▷ A selection window opens.

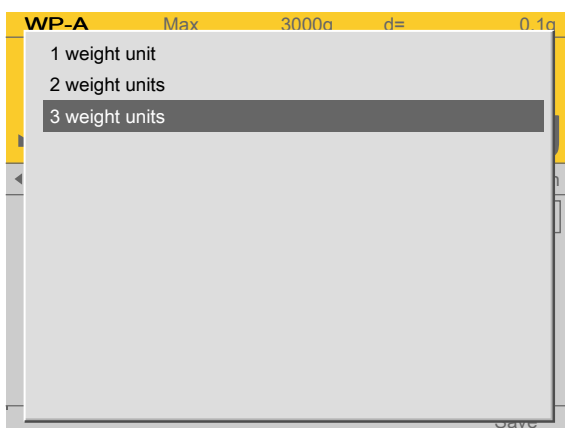

3. Select and confirm [3 weight units].

▷ A selection window opens.

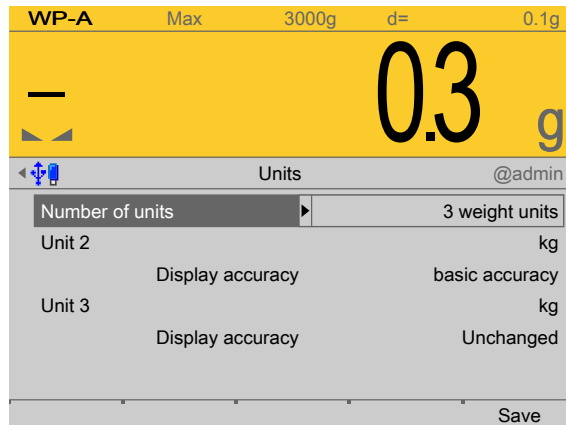

4. Select and confirm the individual parameters.

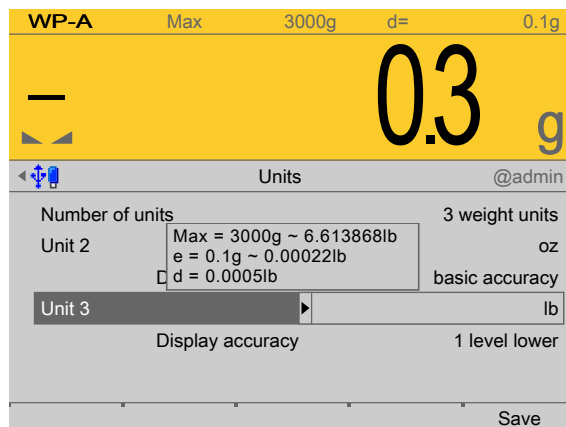

[Unit x]

Selection: kg, t, lb, g, mg, oz

[Display resolution]

Selection: [same], 1 level lower, 2 level lower, 3 level lower, 3 level higher, 2 level higher, 1 level higher

5. Press the [Save] soft key to save the settings.

4.7.2 Liquid counter

In this menu item (under **Weighing points**), the weighing electronics of a **liquid counter** are assigned to a logical weighing point and configured.

- [Parameters] (weighing electronics), see Chapter [4.7.2.1](#).

Liquid counters only affect the internal digital inputs.

- Input 1 = WP-A
- Input 2 = WP-B
- Input 3 = WP-C
- Input 4 = WP-D

The maximum frequency is 200 Hz at a duty ratio of 50:50.

The counter only counts up. "Set zero" resets it.

Accessible via **MENU** - [Operating]- [System setup]- [Weighing points]- [Weighing point x]- [Weighing point]- [Liquid counter] .

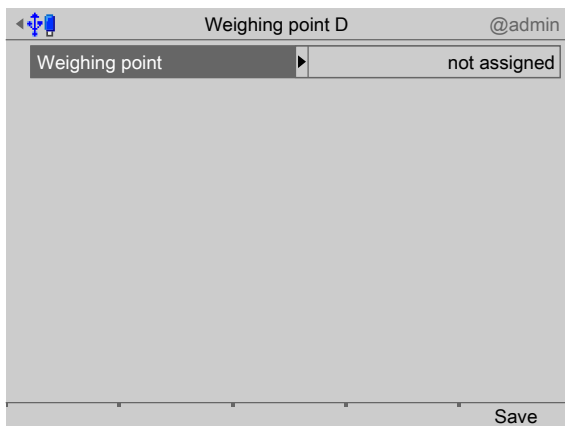

1. Confirm [Weighing point].

▷ A selection window opens.

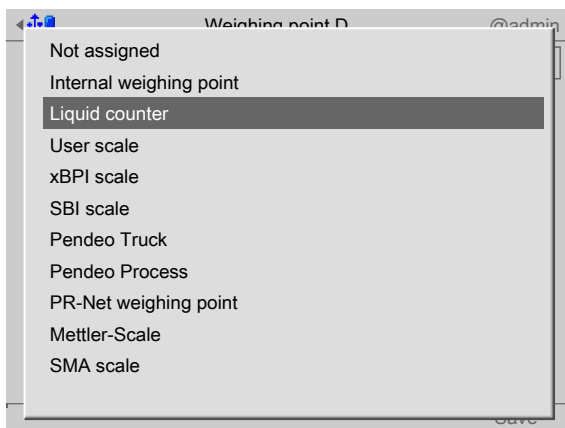

2. Select and confirm [Liquid counter].

3. Press the [Save] soft key to save the settings.

▷ The weighing electronics are now assigned to the weighing point.

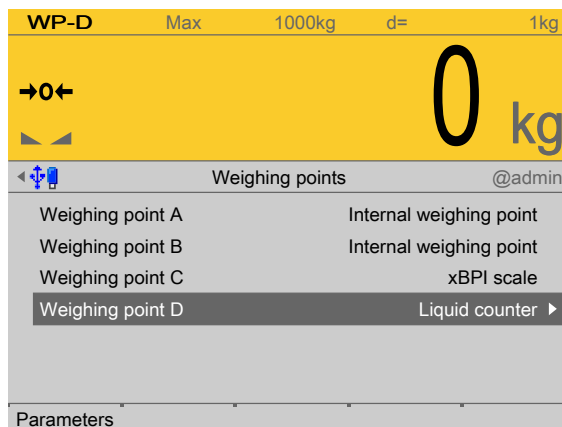

4.7.2.1 Parameters

In this menu item, the parameters of the **Liquid counter** weighing electronics are configured.

Accessible via **MENU** - [Operating] - [System setup] - [Weighing points] - [Weighing point x] - [Parameters] .

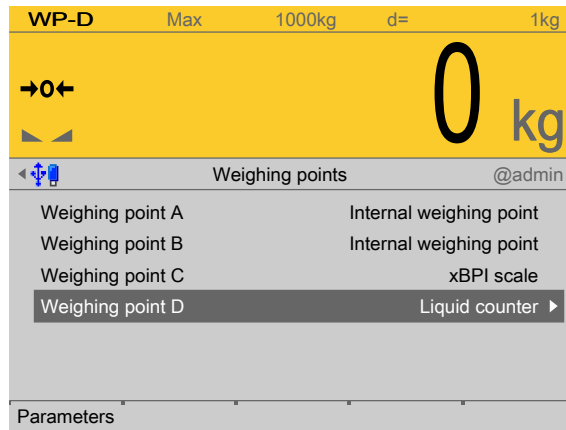

1. In this case: Select [Weighing point D] with [Liquid counter] and press the [Parameters] soft key.

▷ A selection window opens.

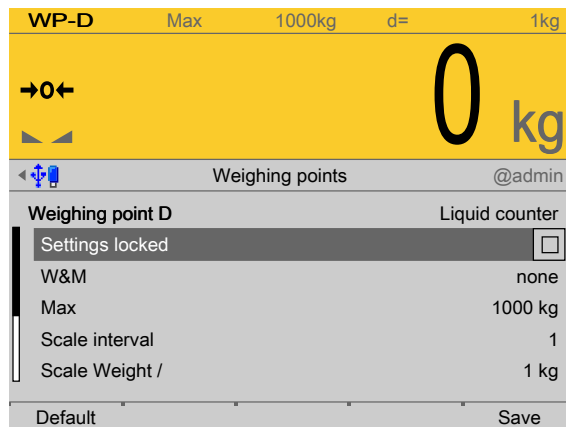

2. Select and confirm the individual parameters.

[Settings locked]

The weighing point settings and assignment can only be viewed as if the corresponding CAL switch were closed; see Chapter [2.7.1](#).

[W&M]

Setting for operation in legal metrology.

Selection: [None], OIML, NTEP (for USA) or NSC (for Australia), see Chapter [4.7.1.1.1](#).

[Max]

Maximum capacity, see Chapter [4.7.1.2.1.1](#).

[Scale interval]

See Chapter [4.7.1.2.1.2](#).

[Weight /]

Weight increase per n scale counts.

Setting range: 0.00010...9999999 in t, kg, g, mg, lb or oz.

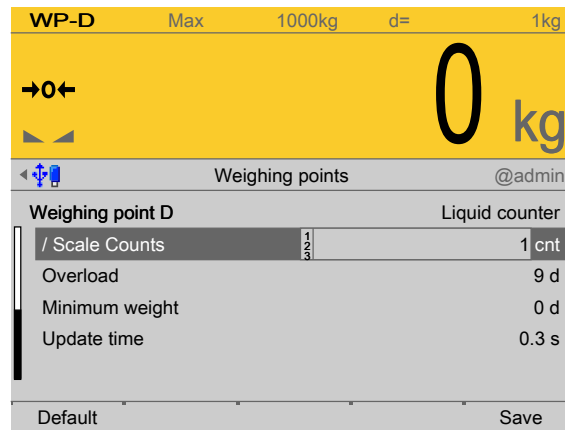
[/ Scale counts]

Number of scale counts for the weight increase entered under [Scale Weight /].

Setting range: 1...65000.

[Overload]

Weighing range above the maximum capacity (Max) without error message.

Setting range: 0...9999999 d.

[Min. weight]

Minimum weight at which a print command can be triggered.

Setting range: 0...9999999 d.

[Update time]

Timeframe in which a new weight value is displayed.

Setting range: 0.1...2.0 s.

[Default] soft key

Settings are reset to factory settings.

3. Press the [Save] soft key to save the settings.
 - ▷ In the [Weighing points] menu, the weight can be displayed with an increased resolution (10-fold); see Chapter 3.8.

4.7.3 User scale

In this menu item (under **Weighing points**), the **user scale** weighing electronics are assigned to a logical weighing point and configured.

- Parameters (weighing electronics), see Chapter 4.7.3.1.

The user-defined weighing point receives data via SPM-Variable. The value contained in this variable is scaled and displayed as the weight value.

This function is used e.g. for

- Describing the SPM-Variable of the OPC server
- Projects

Accessible via **MENU** - [Operating] - [System setup] - [Weighing points] - [Weighing point x] - [Weighing point] - [User scale].

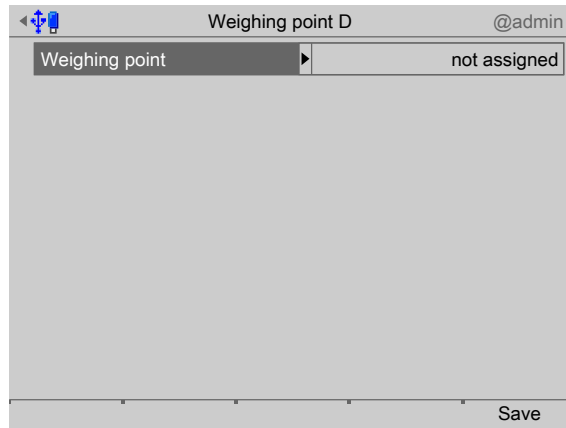

1. Confirm [Weighing point].

▷ A selection window opens.

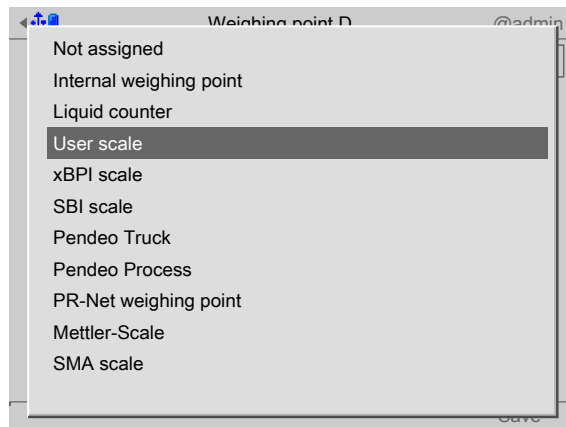

2. Select and confirm [User scale].

3. Press the [Save] soft key to save the settings.

▷ The weighing electronics are now assigned to the weighing point.

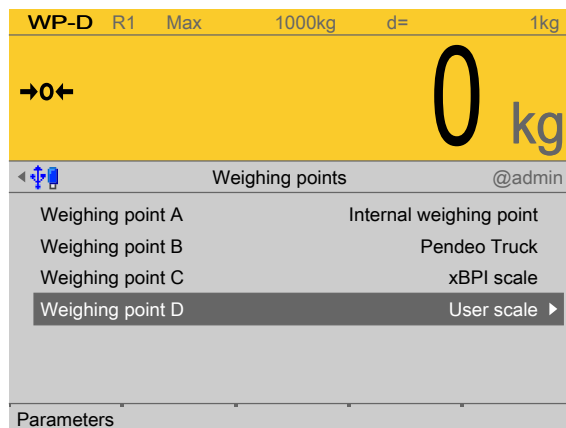

4.7.3.1 Parameters

In this menu item, the parameters of the **user scale** weighing electronics are configured. Accessible via **MENU** - [Operating] - [System setup] - [Weighing points] - [Weighing point x] - [Parameters] .

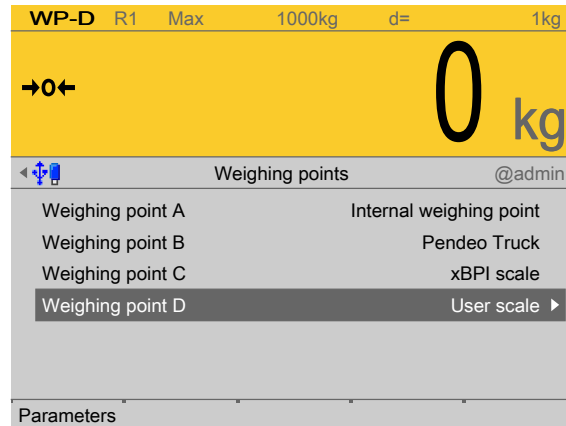

1. In this case: Select [Weighing point D] with [user scale] and press the [Parameters] soft key.

▷ A selection window opens.

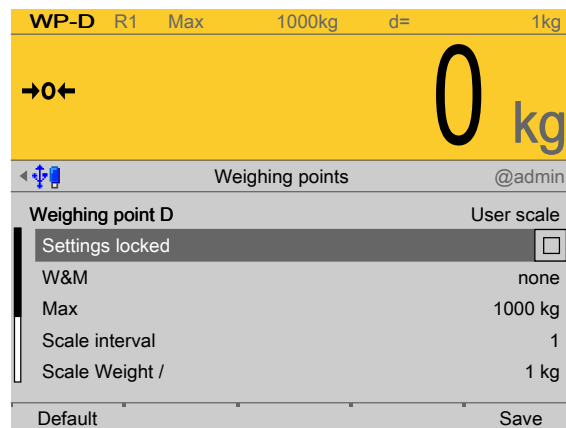

2. Select and confirm the individual parameters.

[Settings locked]

The weighing point settings and assignment can only be viewed as if the corresponding CAL switch were closed; see Chapter [2.7.1](#).

[W&M]

Setting for operation in legal metrology.

Selection: [None], OIML, NTEP (for USA) or NSC (for Australia), see Chapter [4.7.1.1.1](#).

[Max]

Maximum capacity, see Chapter [4.7.1.2.1.1](#).

[Scale interval]

See Chapter [4.7.1.2.1.2](#).

[Weight /]

Weight increase per n scale counts.

Setting range: 0.00010...9999999 in t, kg, g, mg, lb or oz.

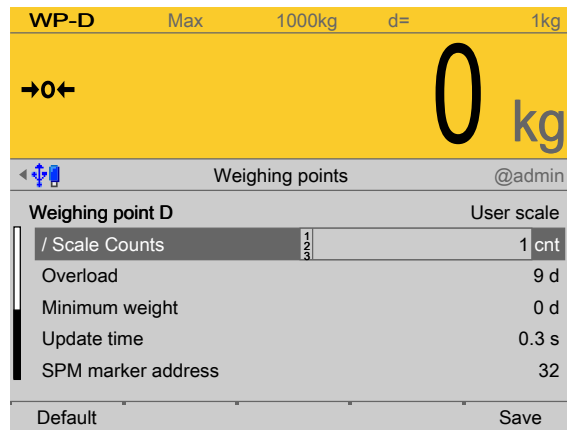
[/ Scale counts]

Number of scale counts for the weight increase entered under [Scale Weight /].

Setting range: 1...65000.

[Overload]

Weighing range above the maximum capacity (Max) without error message.

Setting range: 0...9999999 d.

[Min. weight]

Minimum weight at which a print command can be triggered.

Setting range: 0...9999999 d.

[Update time]

Timeframe in which a new weight value is displayed.

Setting range: 0.1...2.0 s.

[SPM marker address]

Free address for a double integer, i.e., SPM variable for the weight value.

SPM = Scratch Pad Memory.

[Default] soft key

Settings are reset to factory settings.

3. Press the [Save] soft key to save the settings.
 - ▷ In the [Weighing points] menu, the weight can be displayed with an increased resolution (10-fold); see Chapter [3.8](#).

4.7.4 A+B (scale)

In this menu item (under **Weighing points**), the weighing electronics of **two scales** are assigned to a logical weighing point and configured.

- [Parameters] (weighing electronics), see Chapter [4.7.4.1](#).

The scale A+B is selected if e.g. two vehicle weighbridges are to be defined as one scale. The scale A+B can only be assigned to [Weighing point C].

The scale A and the scale B must satisfy the following requirements:

- Same scale interval
- Same unit

Accessible via **MENU** - [Operating] - [System setup] - [Weighing points] - [Weighing point x] - [Weighing point] - [A+B] .

1. Set up weighing point A and calibrate.
2. Set up weighing point B and calibrate.
3. Mark weighing point C and confirm.

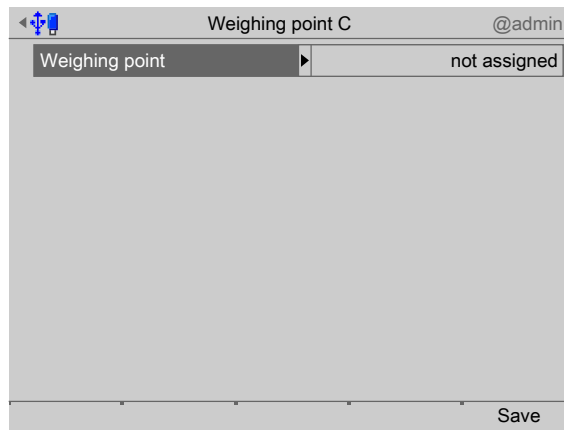

4. Confirm [Weighing point].
 ▷ A selection window opens.

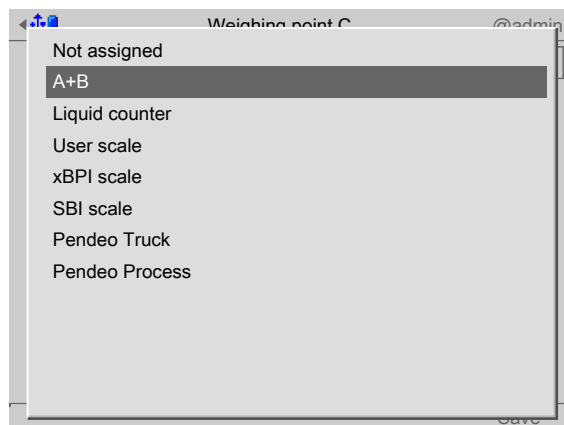

5. Select and confirm [A+B].
6. Press the [Save] soft key to save the settings.

- ▷ The weighing electronics are now assigned to the weighing point.

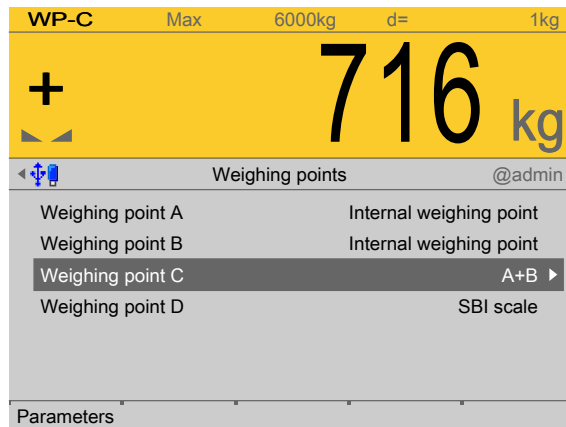

4.7.4.1 Parameters

In this menu item, the parameters of the weighing electronics for **A+B scale** are configured.

Accessible via **MENU** - [Operating] - [System setup]- [Weighing points]- [Weighing point x]- [Parameters] .

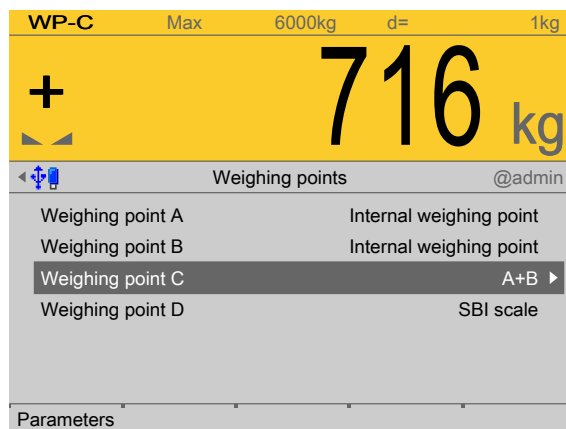

1. In this case: Select [Weighing point C] with [A+B] and press the [Parameters] soft key.
 - ▷ A selection window opens.

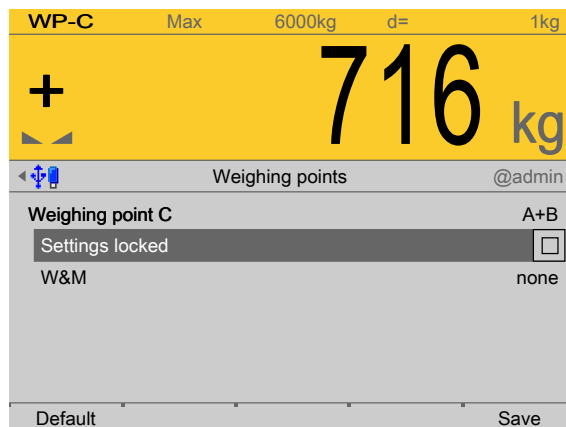

2. Select and confirm the individual parameters.

[Settings locked]

The weighing point settings and assignment can only be viewed as if the corresponding CAL switch were closed; see Chapter [2.7.1](#).

[W&M]

Setting for operation in legal metrology.

Selection: [None], OIML, NTEP (for USA) or NSC (for Australia), see Chapter [4.7.1.1.1](#).

[Default] soft key

Settings are reset to factory settings.

3. Press the [Save] soft key to save the settings.

4.7.5 xBPI scale

In this menu item (under **Weighing points**), the **xBPI scale** weighing electronics are assigned to a logical weighing point and configured.

- [Interface] (serial), see Chapter [4.7.5.1](#).
- [Parameters] (weighing electronics), see Chapter [4.7.5.2](#).
- [Calib], see Chapter [4.7.5.3](#).
- [Units] (display units, display accuracy), see Chapter [4.7.5.4](#).
- [Setup], see Chapter [4.7.5.5](#).

PR 5900 can communicate with scales (e.g. Combics1) or weighing modules via the xBPI protocol.

A maximum of two scales can be connected via serial interfaces (internal or PR 5900/04) (see the PR 5900 installation manual under [Device installation] - [Hardware construction] - [RS-485 interface (internal)] and [Device installation] - [Accessories] - [PR 5900/04 2x RS-485 interface]). Communication is serial.

For restrictions when selecting the scale protocols, see Chapter [4.7](#).

The determination and transmission of weight depends strongly on the scale/weighing module. Weight values up to seven digits plus preceding +/- sign can be displayed. The maximum capacity (Max) must be set in the scale or already set for a platform and cannot be changed via the xBPI protocol.

Accessible via **MENU** – [Operating] - [System setup] - [Weighing points] - [Weighing point x] - [Weighing point] - [xBPI scale].

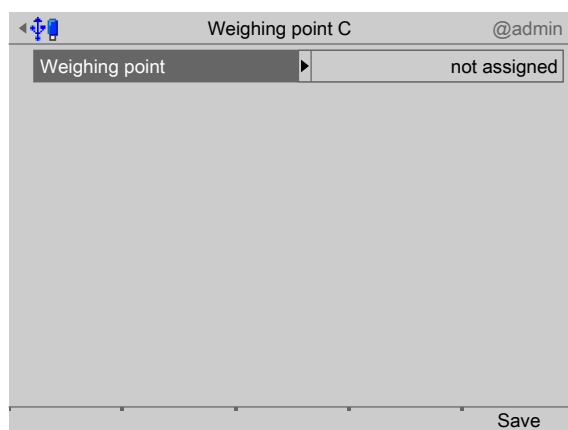

1. Confirm [Weighing point].

▷ A selection window opens.

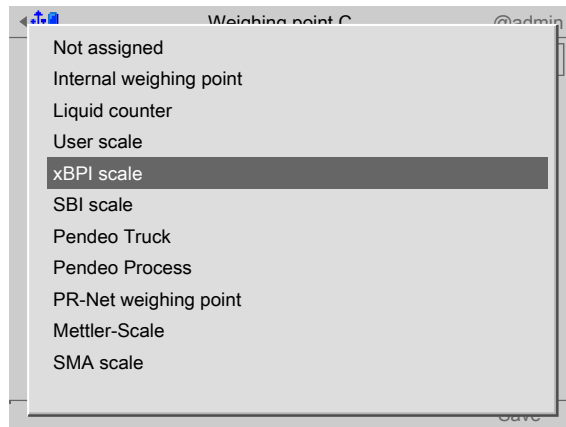

2. Select and confirm [xBPI scale].
 3. Press the [Save] soft key to save the settings.
- ▷ The weighing electronics are now assigned to the weighing point.

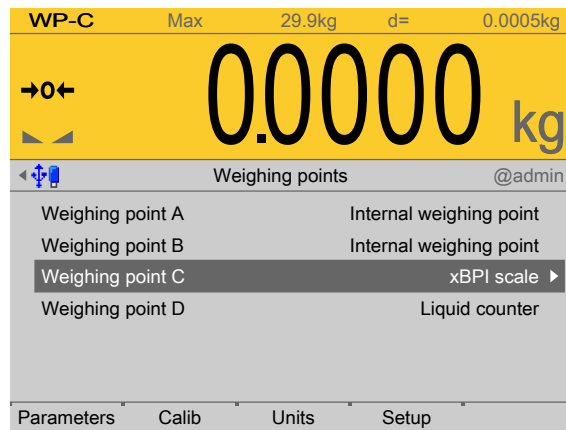

4.7.5.1 Interface (serial)

In this menu item, the parameters of the serial interface for the **xBPI scale** weighing electronics are configured.

Accessible via **MENU** - [Operating] - [System setup] - [Weighing points] - [Weighing point x] - [xBPI scale] - [Interface] .

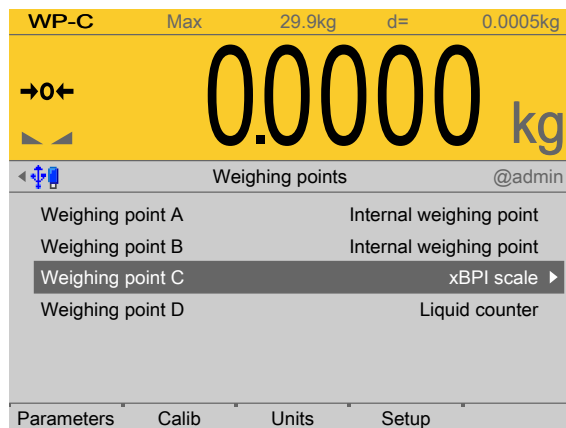

1. In this case: Select and confirm [Weighing point C] with [xBPI scale].

▷ A selection window opens.

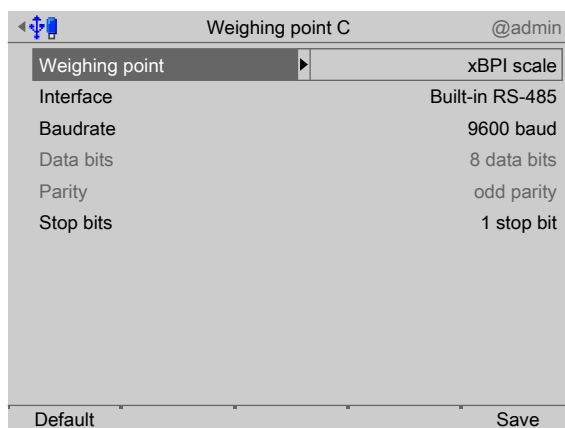

Inactive parameters are grayed out.

2. Select and confirm the individual parameters.

[Interface]

Serial interfaces.

Selection: not assigned, Built-in RS-232, Built-in RS-485, Option-x RS-485-A, Option-x RS-485-B

Note:

If a remote terminal is connected to Maxxis, the RS-485 interface of the remote terminal can also be selected.

[Baud rate]

Baud rate of the data transfer.

Note:

The selected value must match the value of the connected device.

Selection: [9600], 19200, 38400 baud

[Stop bits]

Units for transmission protocols.

Selection: 1 stop bit, [2 stop bits]

[Default] soft key

Settings are reset to factory settings.

3. Press the [Save] soft key to save the settings.

4.7.5.2 Parameters

In this menu item, the parameters of the **xBPI scale** weighing electronics are configured. The following parameters must be configured:

- [Tare timeout], timeout for tare function depending on the application
- [SBN address], the SBN address of each xBPI scale in bus operation
- Serial number of xBPI scale or weighing module, if used in legal metrology

Accessible via **MENU** - [Operating] - [System setup] - [Weighing points] - [Weighing point x] - [xBPI scale] - [Parameters] .

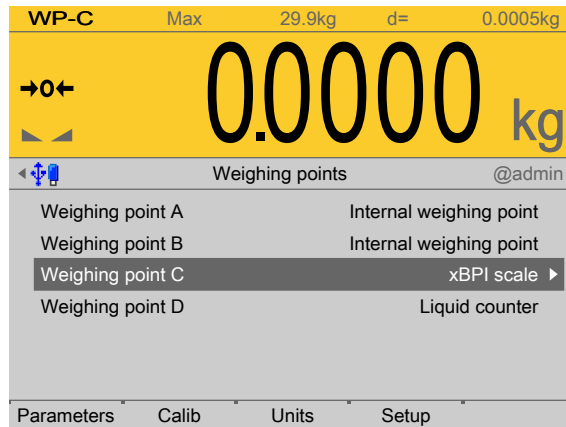

1. In this case: Select [Weighing point C] with [xBPI scale] and press the [Parameters] soft key.

▷ A selection window opens.

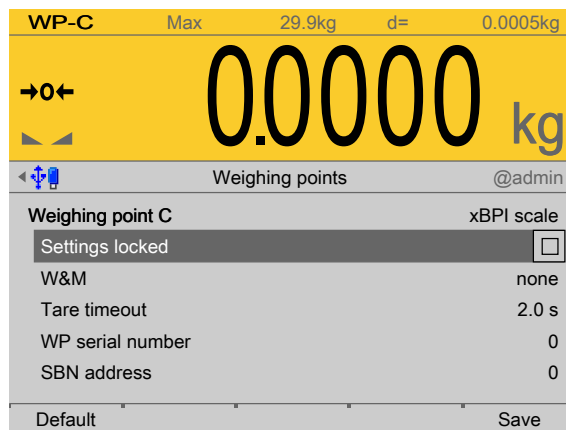

2. Select and confirm the individual parameters.

[Settings locked]

The weighing point settings and assignment can only be viewed as if the corresponding CAL switch were closed; see Chapter [2.7.1](#).

[W&M]

Setting for operation in legal metrology.

Selection: [None], OIML, NTEP (for USA) or NSC (for Australia), see Chapter [4.7.1.1.1](#).

[Tare timeout]

Timeout for a zeroset or tare command to be executed. If the xBPI scale has not executed the command in the specified time, the action will be aborted.

Setting range: 0...9.9 s

[WP serial number]

Serial number of the connected xBPI scale/weighing module. The number is required for checking when used in legal metrology. With serial number 0, checking is omitted.

Setting range: 0 to 99999999

[SBN address]

When the address is not set to 0, bus operation is active. Possible addresses: 1...31, i.e., max. 31 xBPI scales can be operated on an RS-485 branch. The SBN address is shown on the display.

Example: Address 31 on WP-C

WP-C.31	Max	2000kg	d=	2kg
	Min	40kg		

[Default] soft key

Settings are reset to factory settings.

3. Press the [Save] soft key to save the settings.

4.7.5.3 Calib

In this menu item, the **xBPI scale** weighing electronics are calibrated.

- Preload/dead load:
 - [Set] (dead load), see Chapter [4.7.5.3.1](#).
 - [Delete] (dead load), see Chapter [4.7.5.3.2](#).
- SPAN:
 - [Adjust with user weight], see Chapter [4.7.5.3.3](#).
 - [Adjust with automatic weight], see Chapter [4.7.5.3.4](#).
 - [Adjust with default weight], see Chapter [4.7.5.3.5](#).
 - [Adjust with internal weight], see Chapter [4.7.5.3.6](#).
- Linearity:
 - [Default linearization], see Chapter [4.7.5.3.7](#).
 - [User linearization], see Chapter [4.7.5.3.8](#).

Accessible via **MENU** - [Operating] - [System setup] - [Weighing points] - [Weighing point x] - [xBPI scale] - [Calib] .

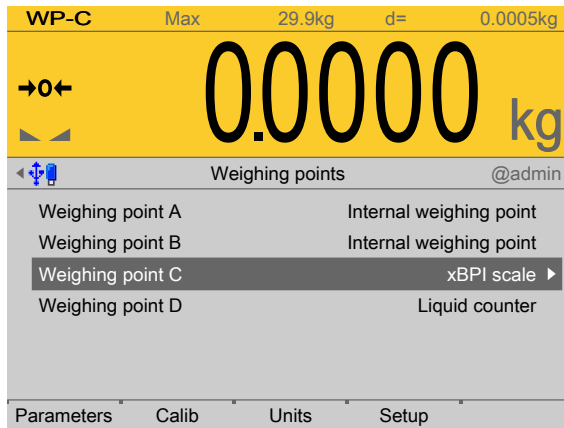

- ▶ In this case: Select [Weighing point C] with [xBPI scale] and press the [Calib] soft key.
 - ▷ The parameters are read from the xBPI scale.

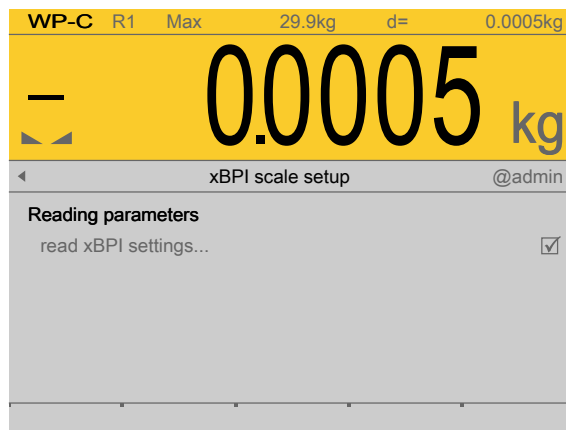

Ticks indicate the progress.

The following error message is displayed if communication with the xBPI scale is not possible:

STOP: "Retrieve failed – timeout in communication"

The xBPI setup menu opens.

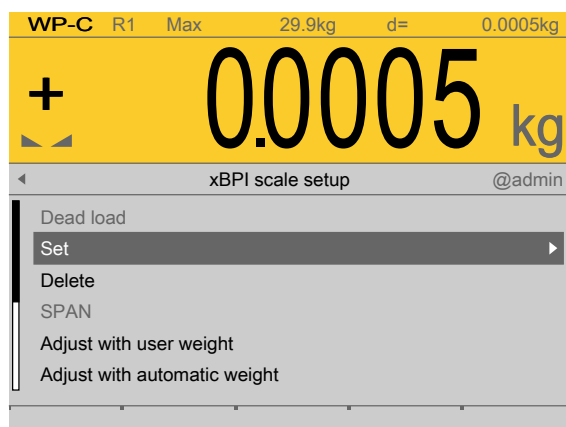

4.7.5.3.1 Set (dead load)

In this menu item (under **Calib**), the dead load/preload of the **xBPI scale** weighing electronics is set.

Note:

For Minebea Intec both terms **dead load** and **preload** are used.

Requirements:

- The communication between the device and xBPI scale is active, and
- the scale parameters have been read, see Chapter [4.7.5.3](#).

Accessible via **MENU** - [Operating] - [System setup] - [Weighing points] - [Weighing point x] - [xBPI scale] - [Calib] - [Set] .

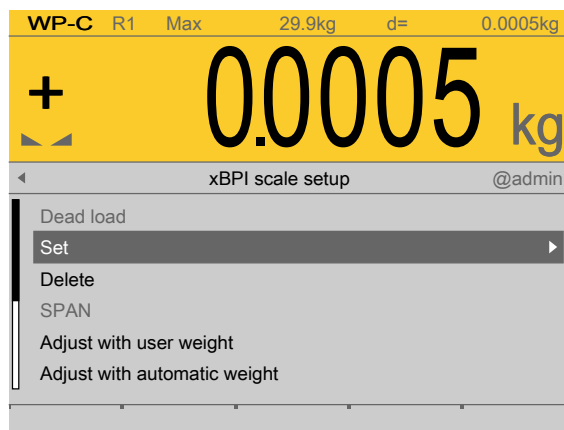

1. Remove the weight from the scale.
2. Select and confirm [Set].
 - ▷ After the command is sent, the gross weight display shows "0."

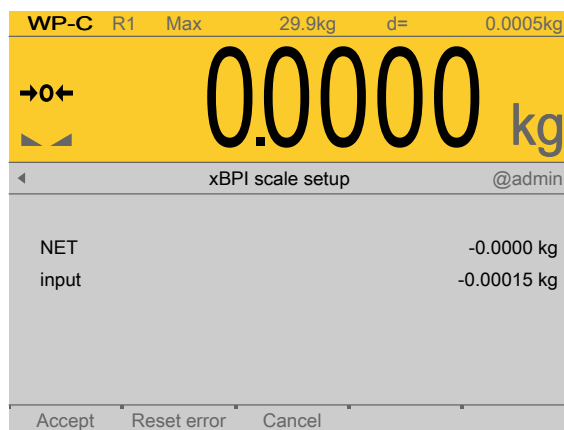

3. Press the **EXIT** key to return to the xBPI setup menu.

4.7.5.3.2 Delete (dead load)

In this menu item (under **Calib**), the dead load/preload of the **xBPI scale** weighing electronics is deleted.

Requirements:

- The communication between the device and xBPI scale is active, and
- the scale parameters have been read, see Chapter [4.7.5.3](#).

Accessible via **MENU** - [Operating] - [System setup] - [Weighing points] - [Weighing point x] - [xBPI scale] - [xBPI scale] - [Calib] - [Delete] .

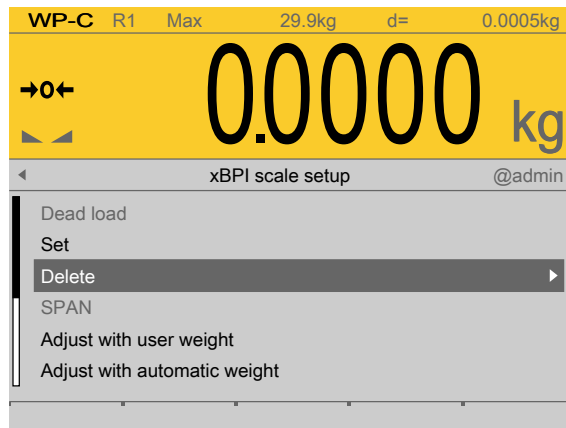

1. Remove the weight from the scale.
2. Select and confirm [Delete].
 - ▷ The stored dead load is deleted. The current dead load is shown on the weight display.

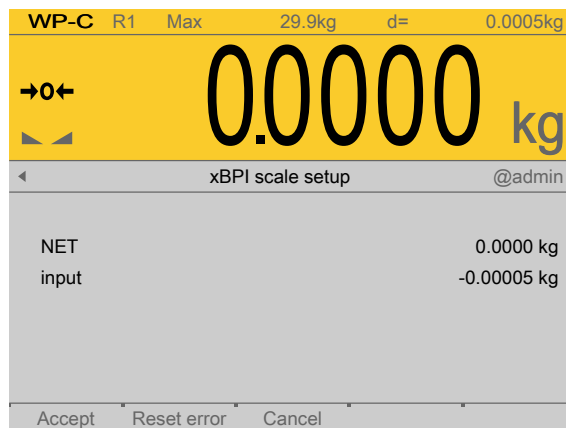

3. Press the **EXIT** key to return to the xBPI setup menu.

4.7.5.3.3 Adjust with user weight

In this menu item, the **xBPI scale** weighing electronics are calibrated with a user-defined weight.

Requirements:

- The xBPI protocol has been selected, see Chapter [4.7.5.1](#).
- The [xBPI scale] weighing point has been selected, see Chapter [4.7.5](#).
- The scale has been set up, see Chapter [4.7.5.5](#).
- [Manual] has been set in the menu [Operating] - [System setup] - [Weighing points] - [Weighing point x] - [Setup] - [Configuration] - [Weighing parameters] - [Confirm calibration] , see Chapter [4.7.5.5.1.1](#).
- The communication between the device and xBPI scale is active.
- the xBPI scale parameters have been read, see Chapter [4.7.5.3](#).

Accessible via **MENU** - [Operating] - [System setup] - [Weighing points] - [Weighing point x] - [xBPI scale] - [Calib] - [Adjust with user weight] .

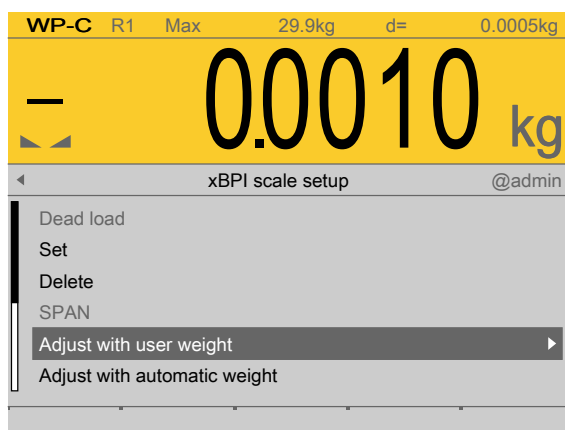

1. Select and confirm [Adjust with user weight].
 - ▷ An input window opens. The previously stored user weight is displayed.

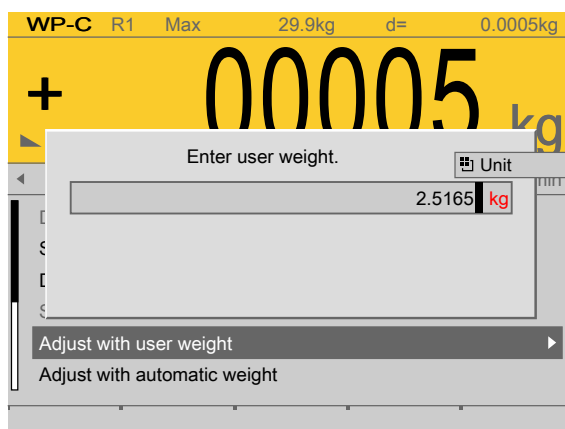

2. If necessary, change the weight value using the keyboard and confirm.
 - ▷ The calibration process is performed without a weight and the calibration check indicates the status.

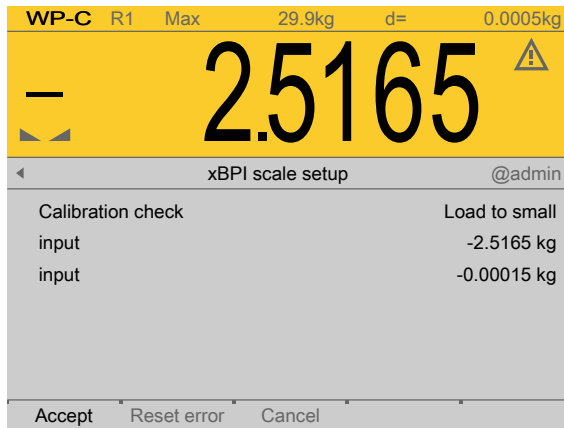

3. Place the weight on the scale.

▷ The deviation is shown. Weight + deviation with 10-fold resolution in the last line.

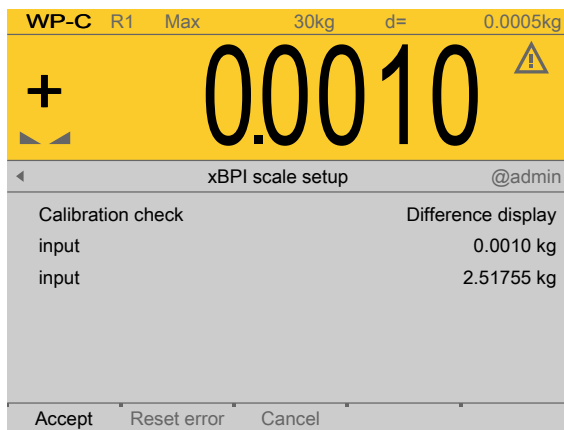

4. Press the [Accept] soft key.

▷ The data is transferred and the calibration check indicates [complete]. The weight is shown. With 10-fold resolution in the last line.

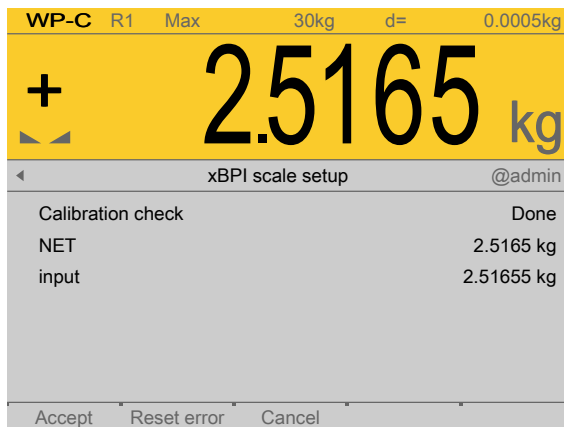

5. Remove the weight.

6. Press the **EXIT** key to return to the xBPI setup menu.

4.7.5.3.4 Adjust with automatic weight

In this menu item, the **xBPI scale** weighing electronics are calibrated with automatic weight detection.

Requirements:

- The xBPI protocol has been selected, see Chapter [4.7.5.1](#).
- The [xBPI scale] weighing point has been selected, see Chapter [4.7.5](#).
- The scale has been set up, see Chapter [4.7.5.5](#).
- [Manual] has been set in the menu [Operating] - [System setup] - [Weighing points] - [Weighing point x] - [Setup] - [Configuration] - [Weighing parameters] - [Confirm calibration] , see Chapter [4.7.5.5.1.1](#).
- The communication between the device and xBPI scale is active.
- the xBPI scale parameters have been read, see Chapter [4.7.5.3](#).

Accessible via **MENU** - [Operating] - [System setup] - [Weighing points] - [Weighing point x] - [xBPI scale] - [Calib] - [Adjust with automatic weight] .

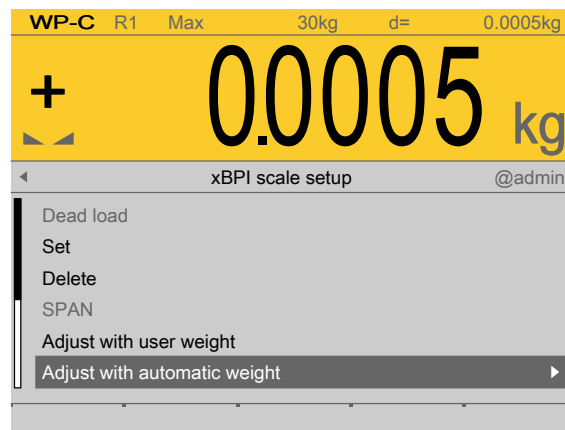

1. Select and confirm [Adjust with automatic weight].
 - ▷ The calibration process is performed without a weight and the calibration check indicates the status.

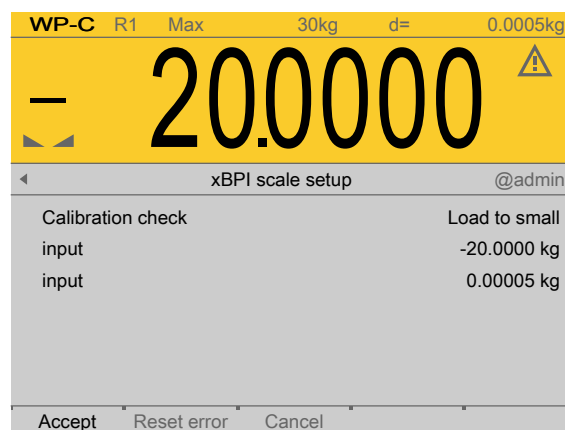

The weight is specified automatically.

2. In this example, a weight of 20 kg is put onto the scale.
 - ▷ The deviation is shown. Weight + deviation with 10-fold resolution in the last line.

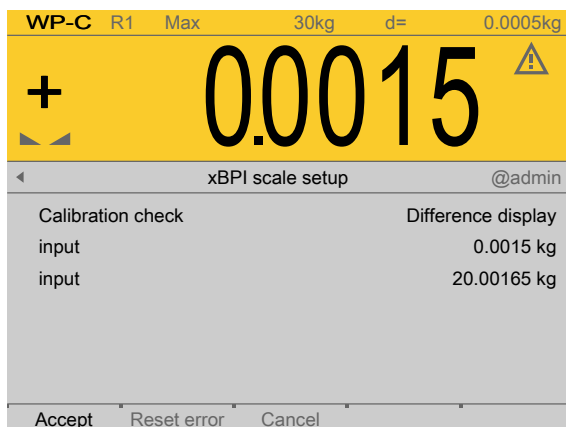

3. Press the [Accept] soft key.

- ▷ The data is transferred and the calibration check indicates [complete]. The weight is shown. With 10-fold resolution in the last line.

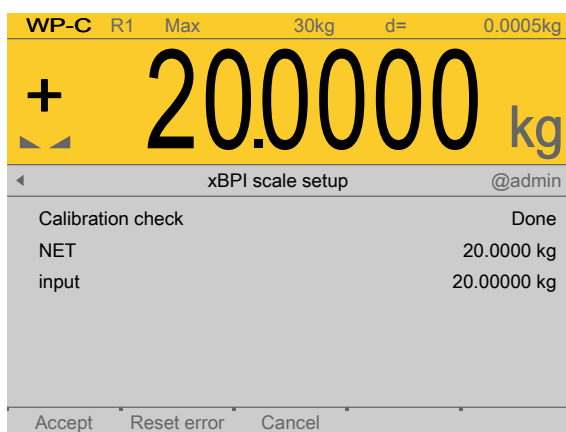

4. Remove the weight.

5. Press the **EXIT** key to return to the xBPI setup menu.

4.7.5.3.5 Adjust with default weight

In this menu item, the **xBPI scale** weighing electronics are calibrated with a default weight.

Requirements:

- The xBPI protocol has been selected, see Chapter [4.7.5.1](#).
- The [xBPI scale] weighing point has been selected, see Chapter [4.7.5](#).
- The scale has been set up, see Chapter [4.7.5.5](#).
- [Manual] has been set in the menu [Operating] - [System setup] - [Weighing points] - [Weighing point x] - [Setup] - [Configuration] - [Weighing parameters] - [Confirm calibration] , see Chapter [4.7.5.5.1.1](#).
- The communication between the device and xBPI scale is active.
- the xBPI scale parameters have been read, see Chapter [4.7.5.3](#).

Accessible via **MENU** - [Operating] - [System setup] - [Weighing points] - [Weighing point x] - [xBPI scale] - [Calib] - [Adjust with default weight] .

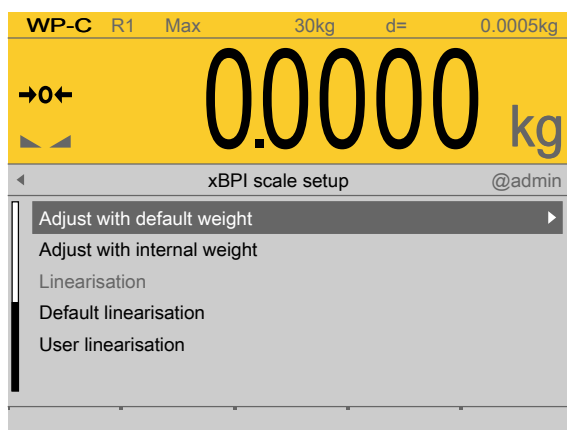

1. Select and confirm [Adjust with default weight].
 - ▷ The calibration process is performed without a weight and the calibration check indicates the status.

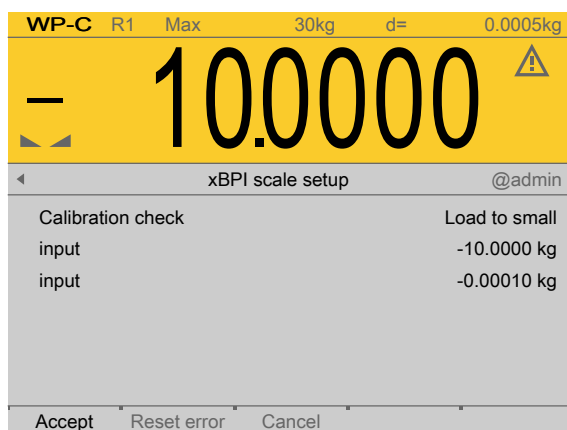

2. Place the weight on the scale.
 - ▷ The deviation is shown. Weight + deviation with 10-fold resolution in the last line.

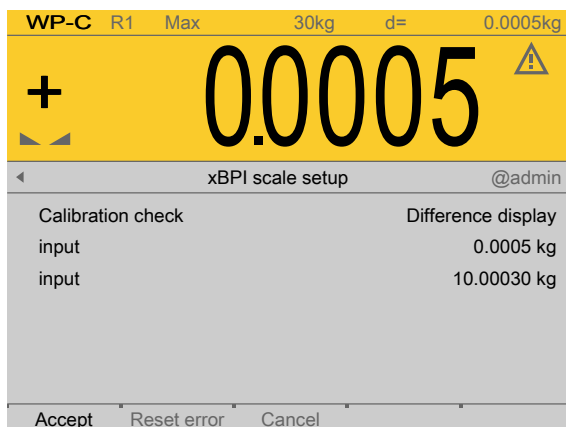

3. Press the [Accept] soft key.

- ▷ The data is transferred and the calibration check indicates [complete]. The weight is shown. With 10-fold resolution in the last line.

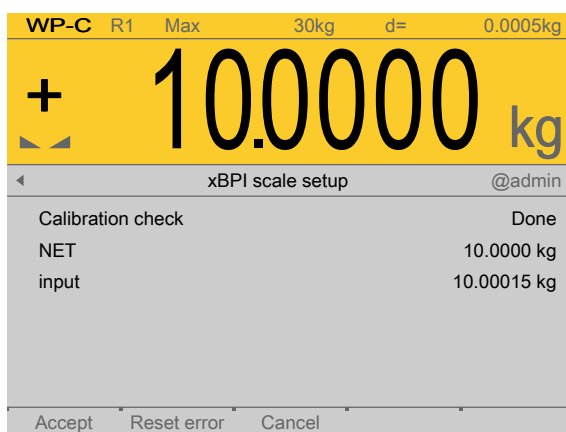

4. Remove the weight.

5. Press the **EXIT** key to return to the xBPI setup menu.

4.7.5.3.6 Adjust with internal weight

In this menu item, the **xBPI scale** weighing electronics are calibrated with an internal weight.

Requirements:

- The xBPI protocol has been selected, see Chapter [4.7.5.1](#).
- The [xBPI scale] weighing point has been selected, see Chapter [4.7.5](#).
- The scale has been set up, see Chapter [4.7.5.5](#).
- [Manual] has been set in the menu [Operating] - [System setup] - [Weighing points] - [Weighing point x] - [Setup] - [Configuration] - [Weighing parameters] - [Confirm calibration] , see Chapter [4.7.5.5.1.1](#).
- The communication between the device and xBPI scale is active.
- the xBPI scale parameters have been read, see Chapter [4.7.5.3](#).

Accessible via **MENU** - [Operating] - [System setup] - [Weighing points] - [Weighing point x] - [xBPI scale] - [Calib] - [Adjust with internal weight] .

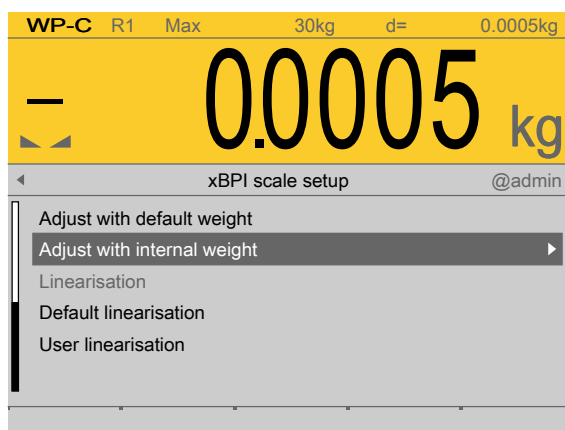

1. Select and confirm [Adjust with internal weight].

▷ The procedure is shown, e.g., with the following messages:

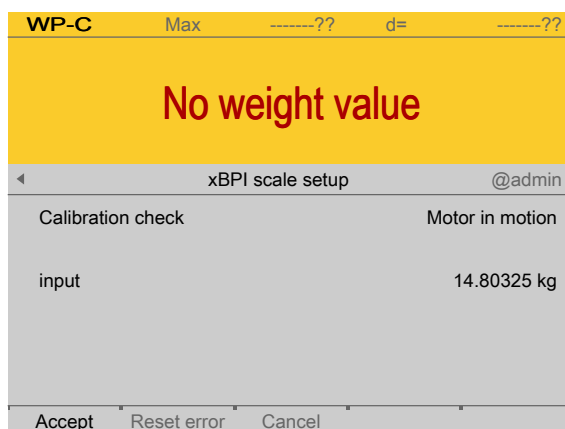

The deviation is shown. Internal weight + deviation in 10-fold resolution in the last line.

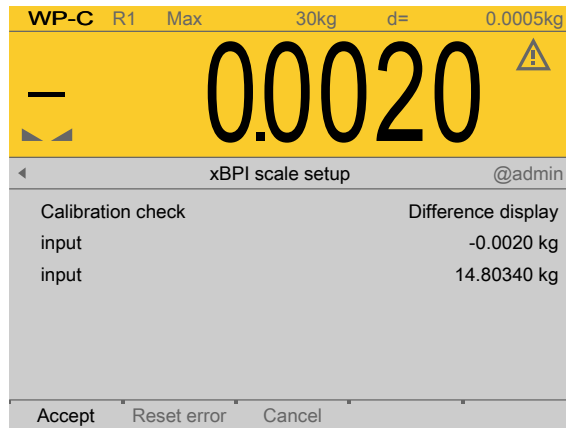

2. Press the [Accept] soft key.

- ▷ The data is transferred and the calibration check indicates [complete]. The weight is shown. With 10-fold resolution in the last line.

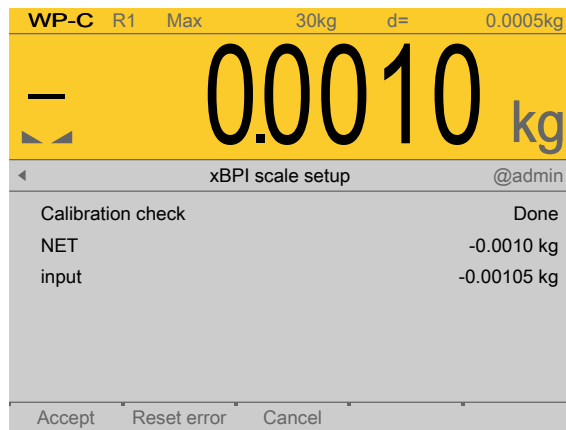

3. Press the **EXIT** key to return to the xBPI setup menu.

4.7.5.3.7 Default linearization

In this menu item, the **xBPI scale** weighing electronics are calibrated with linearization points.

The measurement range for a straight can be optimized by setting the linearization points.

Requirements:

- The xBPI protocol has been selected, see Chapter [4.7.5.1](#).
- The [xBPI scale] weighing point has been selected, see Chapter [4.7.5](#).
- The scale has been set up, see Chapter [4.7.5.5](#).
- [Manual] has been set in the menu [Operating] - [System setup] - [Weighing points] - [Weighing point x] - [Setup] - [Configuration] - [Weighing parameters] - [Confirm calibration] , see Chapter [4.7.5.5.1.1](#).
- The communication between the device and xBPI scale is active.
- the xBPI scale parameters have been read, see Chapter [4.7.5.3](#).

Accessible via **MENU** - [Operating] - [System setup] - [Weighing points] - [Weighing point x] - [xBPI scale] - [Calib] - [Default linearization] .

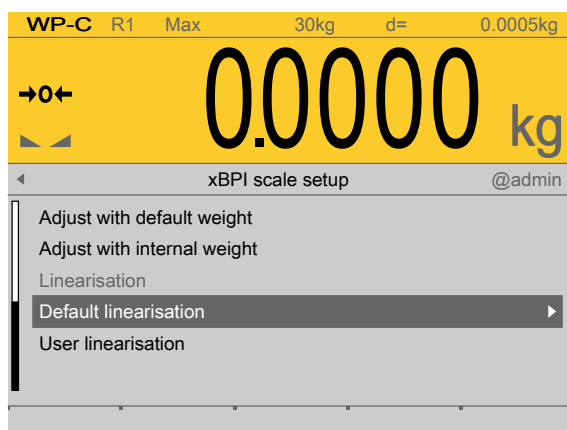

1. Select and confirm [Default linearization].
 - ▷ The first linearization point to be calibrated is displayed.

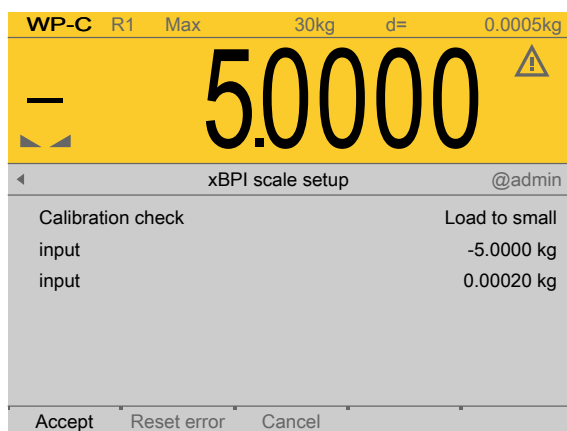

2. Place the displayed weight (here 5 kg) on the scale.
 - ▷ The deviation is shown. Weight + deviation with 10-fold resolution in the last line.

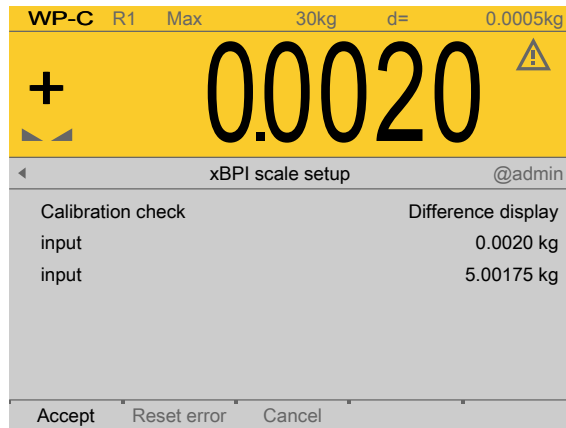

3. Press the [Accept] soft key.

▷ The second linearization point to be calibrated is displayed.

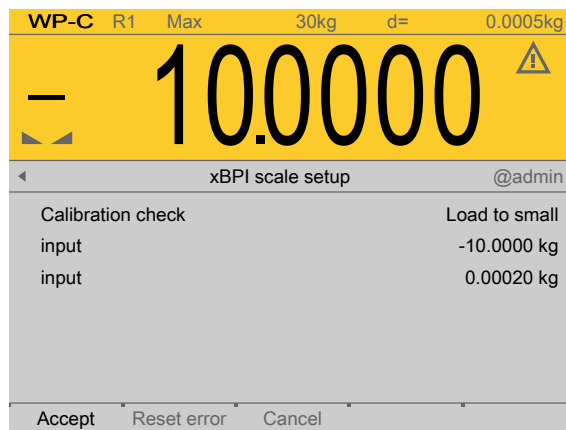

4. Place the displayed weight (here 10 kg) on the scale.

▷ The deviation is shown. Weight + deviation with 10-fold resolution in the last line.

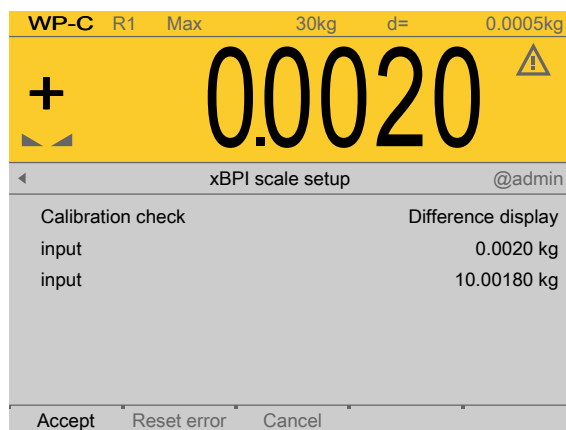

5. Press the [Accept] soft key.

▷ The third linearization point to be calibrated is displayed.

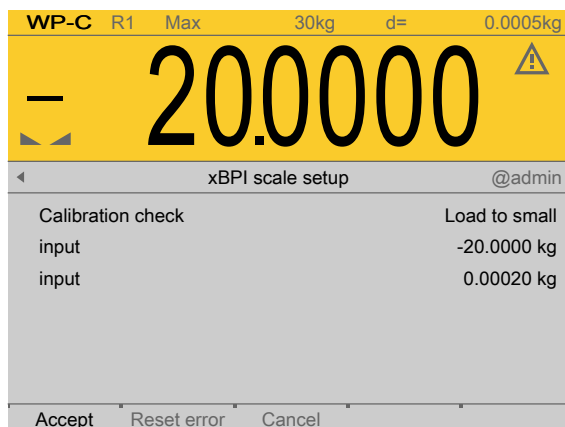

6. Place the displayed weight (here 20 kg) on the scale.
 ▷ The deviation is shown. Weight + deviation with 10-fold resolution in the last line.

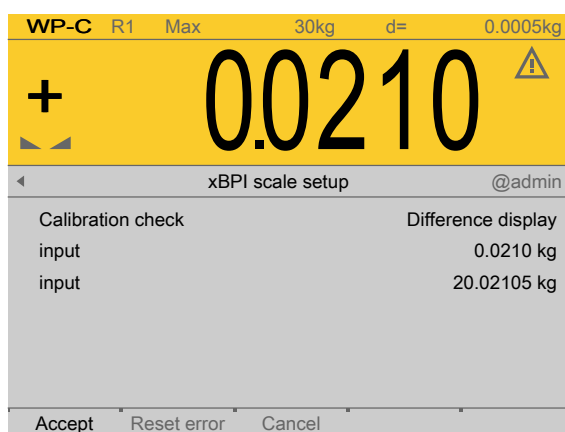

7. Press the [Accept] soft key.
 ▷ The last linearization point to be calibrated is displayed.

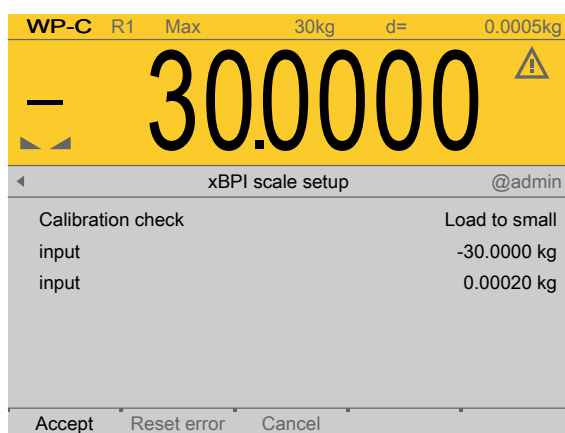

8. Place the displayed weight (here 30 kg) on the scale.
 ▷ The deviation is shown. Weight + deviation with 10-fold resolution in the last line.

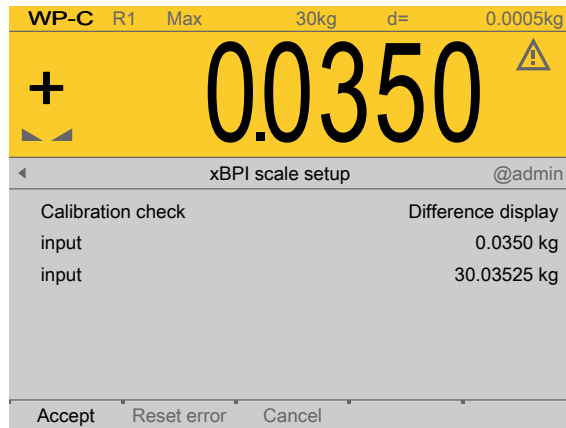

9. Press the [Accept] soft key.
10. Press the **EXIT** key to return to the xBPI setup menu.

4.7.5.3.8 User linearization

In this menu item, the **xBPI scale** weighing electronics are calibrated with user linearization points.

The measurement range for a straight can be optimized by setting the linearization points.

Requirements:

- The xBPI protocol has been selected, see Chapter [4.7.5.1](#).
- The [xBPI scale] weighing point has been selected, see Chapter [4.7.5](#).
- The scale has been set up, see Chapter [4.7.5.5](#).
- [Manual] has been set in the menu [Operating] - [System setup] - [Weighing points] - [Weighing point x] - [Setup] - [Configuration] - [Weighing parameters] - [Confirm calibration], see Chapter [4.7.5.5.1.1](#).
- The communication between the device and xBPI scale is active.
- the xBPI scale parameters have been read, see Chapter [4.7.5.3](#).

Accessible via **MENU** - [Operating] - [System setup] - [Weighing points] - [Weighing point x] - [xBPI scale] - [Calib] - [User linearization] .

The [user linearization] is described using [**default linearization**] as an example, see Chapter [4.7.5.3.7](#).

4.7.5.4 Units

In this menu item, the display units and the display accuracy of the **xBPI scale** weighing electronics are configured.

The device is calibrated with a selected weight unit.

Accessible via **MENU** - [Operating] - [System setup] - [Weighing points] - [Weighing point x] - [xBPI scale] - [Units] .

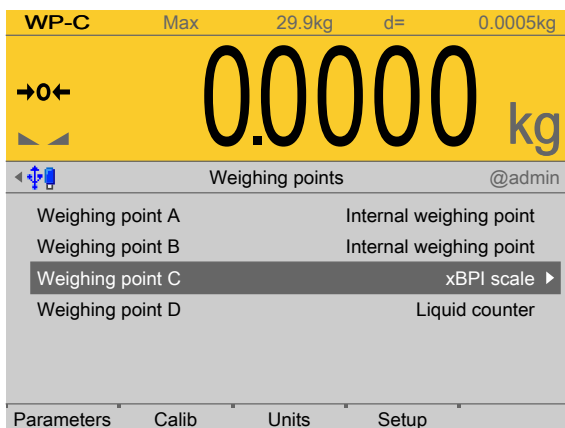

- ▶ In this case: Select [Weighing point C] with [xBPI scale] and press the [Units] soft key. For selecting the units and the associated display accuracy, see Chapter [4.7.1.3](#).

4.7.5.5 Setup

In this menu item, all important data is loaded from the scale onto the device following connection with the **xBPI scale**.

- [Configuration], see Chapter [4.7.5.5.1](#).
- [Select group of specifications], see Chapter [4.7.5.5.2](#).
- [Device information], see Chapter [4.7.5.5.3](#).

Accessible via **MENU** - [Operating] - [System setup] - [Weighing points] - [Weighing point x] - [xBPI scale] - [Setup] .

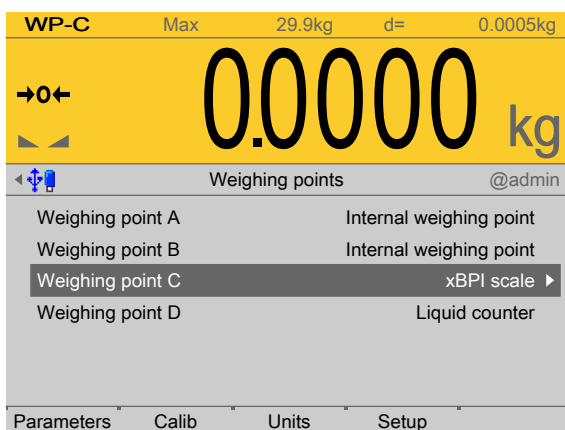

- ▶ In this case: Select [Weighing point C] with [xBPI scale] and press the [Setup] soft key.
 - ▷ The parameters are read from the xBPI scale. Ticks indicate the progress.

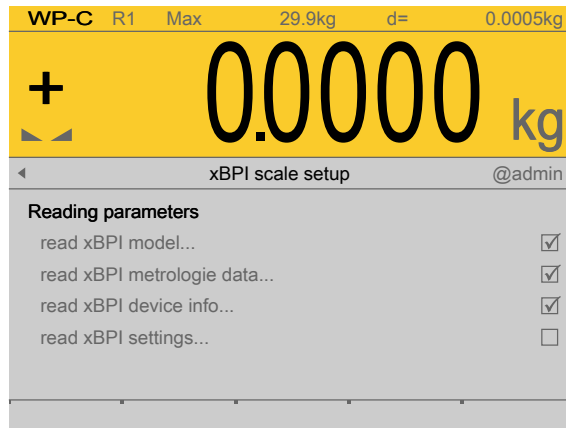

The xBPI setup menu opens.

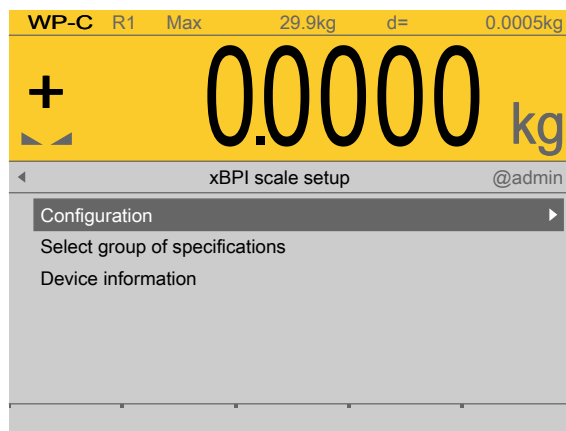

Possible error message:

"Retrieve failed – timeout in communication"

This message is displayed if communication with the xBPI scale is not possible.

4.7.5.5.1 Configuration

In this menu item (under **Setup**), the scale and interface parameters of the **xBPI scale** weighing electronics are configured.

- [Weighing parameters], see Chapter [4.7.5.5.1.1](#).
- [Interface parameters], see Chapter [4.7.5.5.1.2](#).

Accessible via **MENU** - [Operating] - [System setup] - [Weighing points] - [Weighing point x] - [xBPI scale] - [Setup] - [Configuration] .

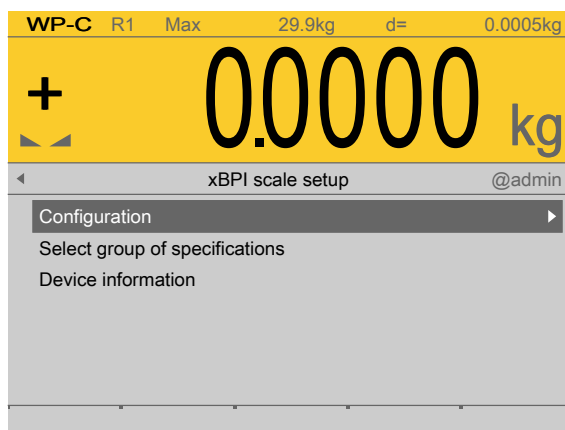

- ▶ Select and confirm [Configuration].
 - ▷ The xBPI parameter setup menu opens.

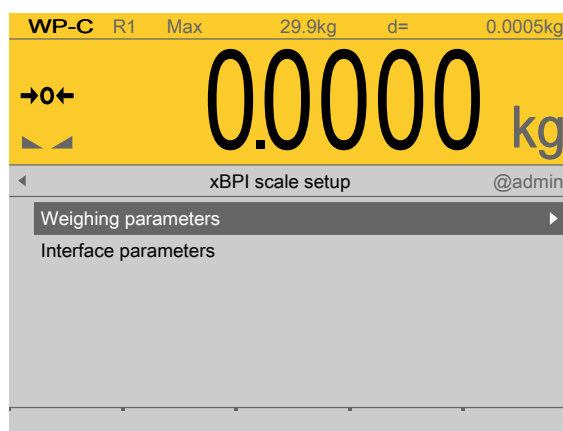

4.7.5.5.1.1 Weighing parameters

In this menu item (under **Configuration**), the weighing parameters of the **xBPI scale** weighing electronics are configured.

Accessible via **MENU** - [Operating] - [System setup] - [Weighing points] - [Weighing point x] - [xBPI scale] - [Setup] - [Configuration] - [Weighing parameters] .

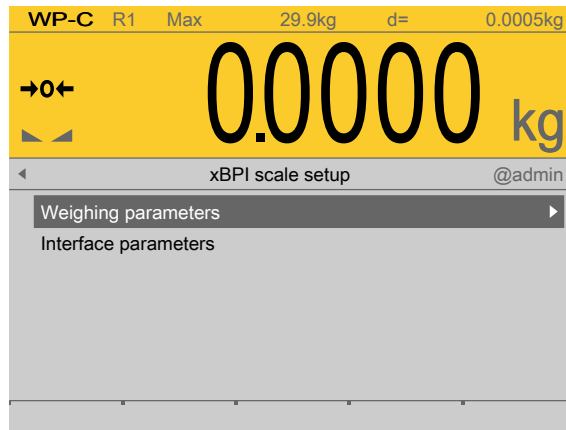

1. Select and confirm [Weighing parameters].

▷ A selection window opens.

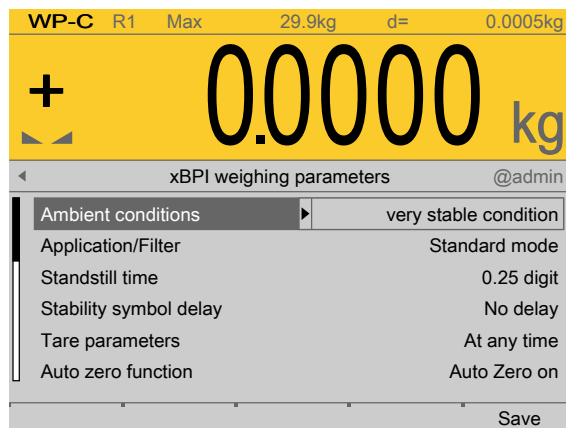

2. Select the individual parameters and confirm.

Note:

Only the parameters supported by the connected scale are displayed.

[Ambient conditions]

Selection: very stable condition, Stable condition, Unstable condition, Very unstable condition

[Application/Filter]

Selection: Standard Mode, manual filling, automatic dosing, Checkweighing

[Standstill range]

Selection: 0.25 digit, 0.5 digit, 1 digits, 2 digits, 4 digits, 8 digits

[Stability symbol delay]

Selection: No delay, Short delay, Average delay, Long delay

[Tare parameters]

Selection: At any time, Not until stable

[Auto zero function]

Selection: on, off

[Adjustment function]

Selection: Ext.adj.w.fact.wt., Ext.adj.w.user wt., Ext.adj.w.pres.wt., Internal adjust, Ext.lin.w.fact.wt., Ext.lin.w.user wt., Confirm preload/dead load, Delete preload/dead load, Adjust disabled

[Confirming adjustment]

Selection: automatically, manual

[Zero range]

Selection: 1 % of max. load, 2 % of max. load, 5 % of max. load, 10 % of max. load

[Power-on zero range]

Selection: Factory settings, 2 % of max. load, 5 % of max. load, 10 % of max. load, 20 % of max. load

[Power-on tare/zero]

Selection: Active, Inactive, Only for zeroing

[Measuring rate]

Selection: Normal output, Fast output

[Calibration check]

Selection: No calibration prompt, Calibration prompt

[External Adjustment]

Selection: Accessible, Blocked

[Application Tare]

Selection: Accessible, Blocked

[Maximum capacity]

Selection: Reduced by pre-/dead load, Constant

3. Press the [Save] soft key to save the settings.

4.7.5.5.1.2 Interface parameters

In this menu item (under **Configuration**), the interface parameters of the **xBPI scale** weighing electronics are configured.

Accessible via **MENU** - [Operating] - [System setup] - [Weighing points] - [Weighing point x] - [xBPI scale] - [Setup] - [Configuration] - [Interface parameters] .

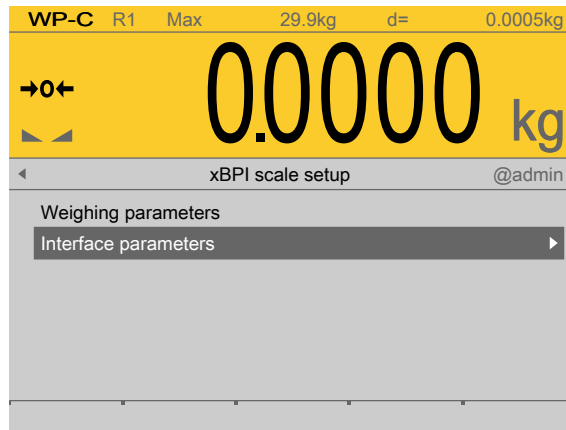

1. Select and confirm [Interface parameters].

▷ A selection window opens.

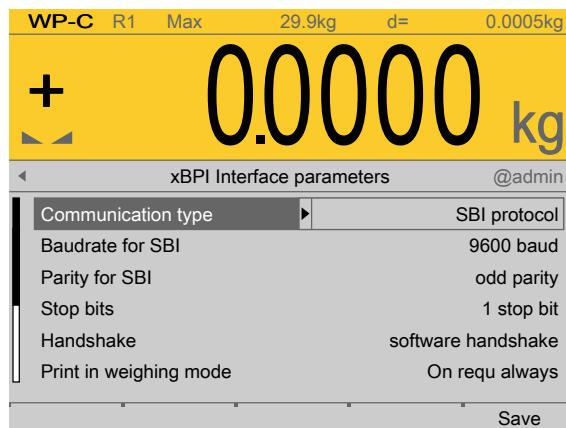

2. Select [Communication type] and confirm.
3. Select [SBI protocol] or [xBPI protocol] and confirm.
4. Select and confirm the individual parameters according to the choice.

SBI protocol:

[Baudrate für SBI]

Selection: 150, 300, 600, 1200, 2400, 4800, 9600, 19200 baud

[Parity for SBI]

Selection: Parity mark, Parity space, odd parity, even parity

[Stop bits]

Selection: 1 stop bit, 2 stop bits

[Handshake]

Selection: software handshake, CTS with 2 characters, CTS with 1 character

[Print in weighing mode]

Selection: On requ always, On requ when stab, On requ with store, auto, auto when stable

[auto print]

Selection: Start/stop by ESCP, not stoppable

[Output format]

Selection: without ID 16 bytes, with ID 22 bytes

[Data output interval]

Selection: each display cycle, after 2, 5, 10, 20, 50, 100 updates

[Parameters change]

Selection: Can be changed, Cannot be changed

xBPI protocol:**[Data output interval]**

Selection: each display cycle, after 2, 5, 10, 20, 20, 50, 100 updates

[Parameters change]

Selection: Can be changed, Cannot be changed

5. Press the [Save] soft key to save the settings.

4.7.5.5.2 Select group of specifications

In this menu item (under **Setup**), the specification groups of the **xBPI scale** weighing electronics are configured.

Accessible via **MENU** - [Operating] - [System setup] - [Weighing points] - [Weighing point x] - [xBPI scale] - [Setup] - [Select group of specifications] .

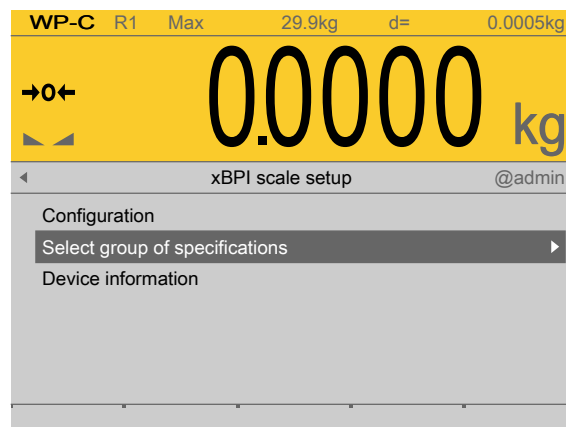

1. Select and confirm [Select group of specifications].

Note:

The following is required for setting up the specification group:

- The model name of the scale
- The number of the corresponding specification block (see scale operating instructions).

Some xBPI scales have what are known as "specification blocks" for selecting various modes of operation (single range, multiple range, etc.).

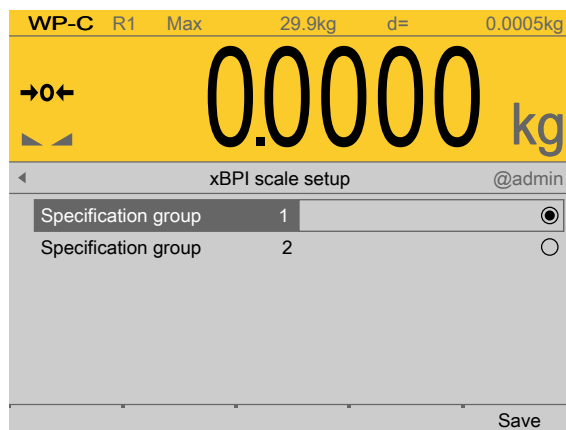

2. Select and confirm the desired group of specifications.
3. Press the [Save] soft key to save the settings.

4.7.5.5.3 Device information

In this menu item (under **Setup**), the device information parameters of the **xBPI scale** weighing electronics are configured.

Accessible via **MENU** - [Operating] - [System setup] - [Weighing points] - [Weighing point x] - [xBPI scale] - [Setup] - [Device information] .

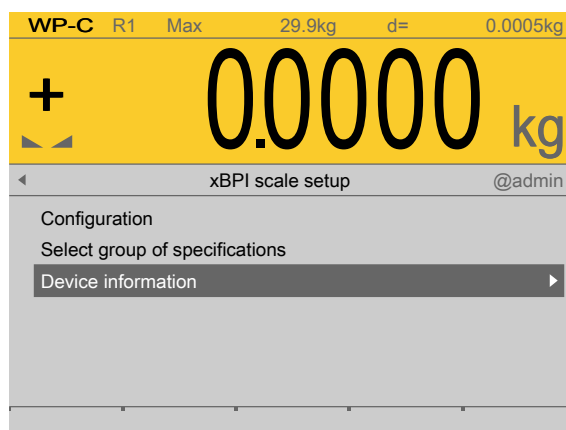

1. Select and confirm [Device information].
 - ▷ The Device information window opens.

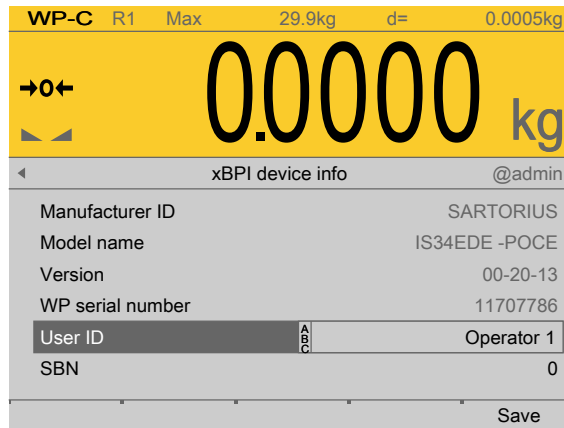

Inactive parameters are grayed out.

2. Change the user ID and SBN (see Chapter [4.7.5.2](#)) if necessary.
3. Press the [Save] soft key to save the settings.

4.7.6 SBI scale

In this menu item (under **Weighing points**), the **SBI scale** weighing electronics are assigned to a logical weighing point and configured.

- [Interface] (serial), see Chapter [4.7.6.1](#).
- [Parameters] (weighing electronics), see Chapter [4.7.6.2](#).

PR 5900 can communicate with scales (e.g. Combics1) or weighing modules via the SBI protocol. The devices can be connected via serial interfaces (internal or PR 5900/04) (see the PR 5900 installation manual under [Device installation] - [Hardware construction] - [RS-485 interface (internal)] and under [Device installation] - [Accessories] - [PR 5900/04 2x RS-485 interface]). Communication is serial.

Accessible via **MENU** - [Operating] - [System setup] - [Weighing points] - [Weighing point x] - [Weighing point] - [SBI scale].

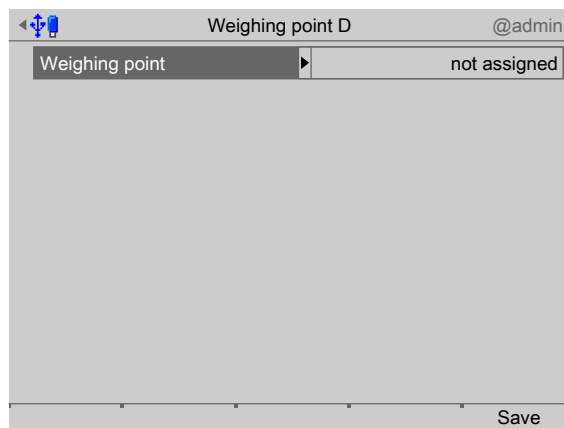

1. Confirm [Weighing point].

▷ A selection window opens.

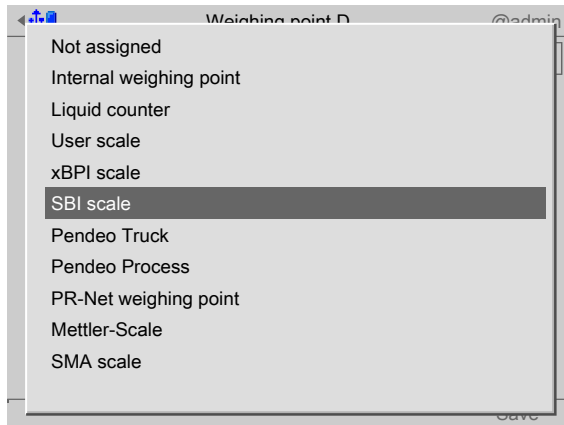

2. Select and confirm [SBI scale].
 3. Press the [Save] soft key to save the settings.
- ▷ The weighing electronics are now assigned to the weighing point.

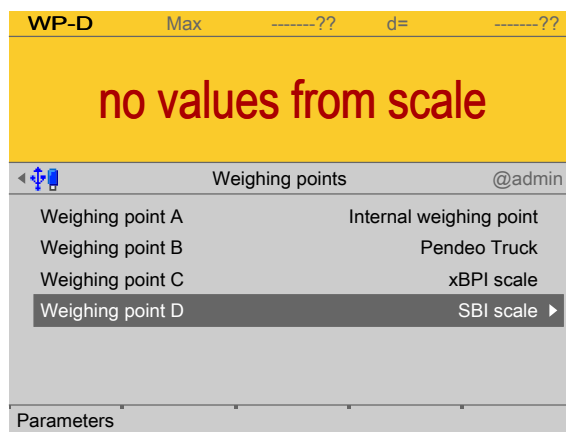

4.7.6.1 Interface (serial)

In this menu item, the parameters of the serial interface for the **SBI scale** weighing electronics are configured.

Accessible via **MENU** - [Operating] - [System setup] - [Weighing points] - [Weighing point x] - [Interface] .

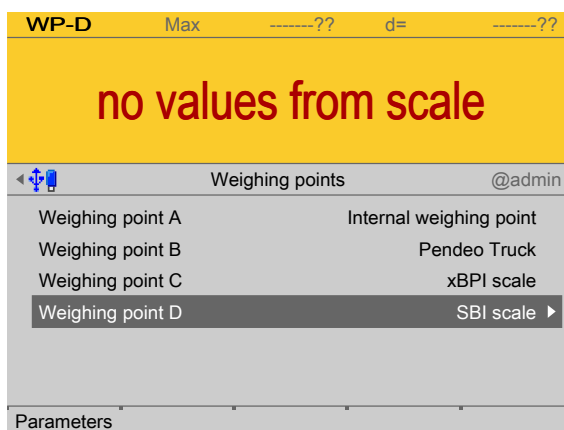

1. In this case: Select and confirm [Weighing point D] with [SBI scale].

▷ A selection window opens.

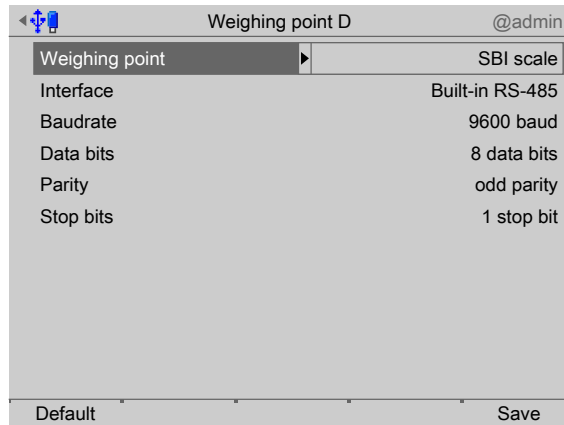

2. Select and confirm the individual parameters.

[Interface]

Serial interfaces.

Selection: not assigned, Built-in RS-232, Built-in RS-485, Option-x RS-485-A, Option-x RS-485-B

[Baud rate]

Baud rate of the data transfer.

Note:

The selected value must match the value of the connected device.

Selection: 300, 600, 1200, 2400, 4800, [9600], 19200 baud

[Data bits]

Groups of data bits.

Selection: 7 data bits, [8 data bits]

[Parity]

Parity check for detecting errors during data transmission.

Selection: no parity, odd parity, even parity

[Stop bits]

Units for transmission protocols.

Selection: 1 stop bit, [2 stop bits]

[Default] soft key

Settings are reset to factory settings.

3. Press the [Save] soft key to save the settings.

4.7.6.2 Parameters

In this menu item, the parameters of the **SBI scale** weighing electronics are configured. Accessible via **MENU** - [Operating] - [System setup] - [Weighing points] - [Weighing point x] - [Parameters] .

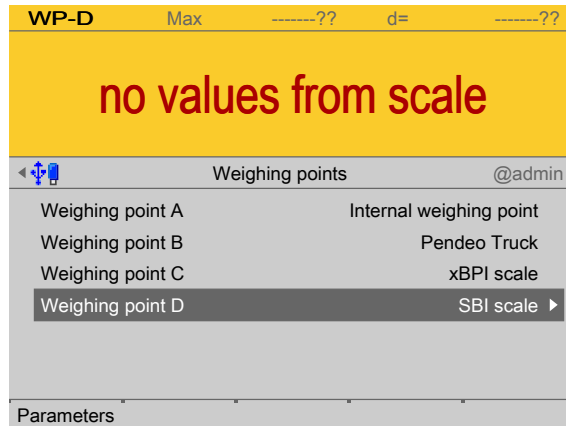

1. In this case: Select [Weighing point D] with [SBI scale] and press the [Parameters] soft key.

▷ A selection window opens.

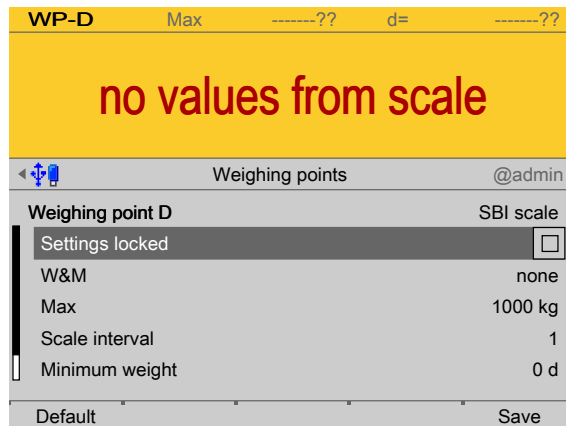

2. Select and confirm the individual parameters.

[Settings locked]

The weighing point settings and assignment can only be viewed as if the corresponding CAL switch were closed; see Chapter [2.7.1](#).

[W&M]

Setting for operation in legal metrology.

Selection: [None], OIML, NTEP (for USA) or NSC (for Australia), see Chapter [4.7.1.1.1](#).

[Max] (maximum capacity)

see Chapter [4.7.1.2.1.1](#).

[Scale interval]

See Chapter [4.7.1.2.1.2](#).

[Min. weight]

Minimum weight at which a print command can be triggered.

Setting range: 0...9999999 d.

For use in legal metrology a value of at least 20 d must be set.

[Update time]

Timeframe in which a new weight value is displayed.

Setting range: 0.1...2.0 s.

[Default] soft key

Settings are reset to factory settings.

3. Press the [Save] soft key to save the settings.

4.7.7 Pendeo Truck

In this menu item (under **Weighing points**), the digital weighbridge load cell **Pendeo® Truck** is assigned to a logical weighing point and configured.

- [Interface] (serial), see Chapter [4.7.7.1](#).
- [Parameters] (load cells), see Chapter [4.7.7.2](#).
- [Calib], see Chapter [4.7.7.3](#).
- [Units] (display accuracy), see Chapter [4.7.7.4](#).

The digital load cells have been calibrated at the factory based on the acceleration of gravity at Hamburg (9.81379 m/s²). The calibration data in the load cells are invariable. The calibration data for the gravity acceleration at the place of installation can be adapted only in the device and protected against overwriting (see Chapter [2.7](#)). With applications for use in legal metrology, the legal requirements and the conditions given on the test/ approval certificate must be taken into account when selecting the settings.

Accessible via **MENU** - [Operating] - [System setup] - [Weighing points] - [Weighing point x] - [Weighing point] - [Pendeo Truck] .

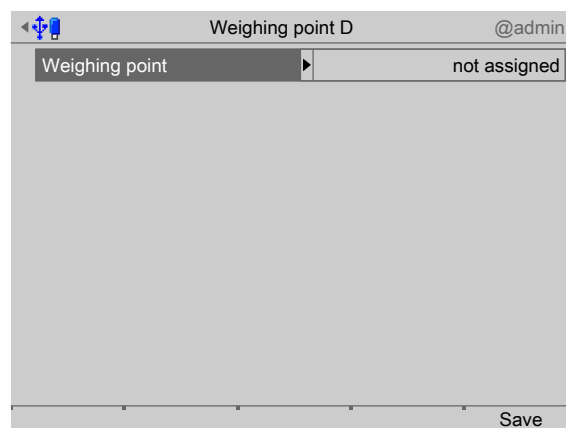

1. Confirm [Weighing point].

- ▷ A selection window opens.

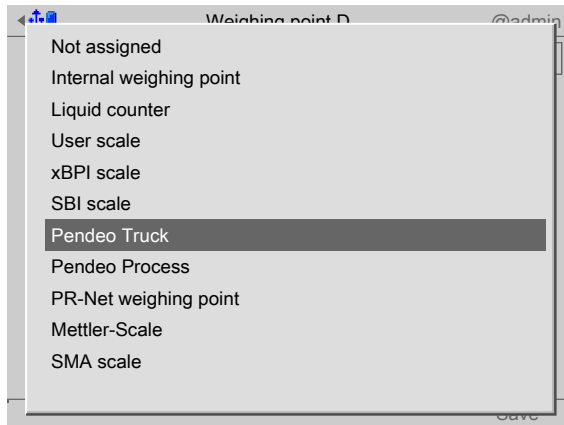

2. Select and confirm [Pendeo Truck].
 3. Press the [Save] soft key to save the settings.
- ▷ The weighing electronics are now assigned to the weighing point.

If a scale has not yet been connected, the message "scale not ready" appears.

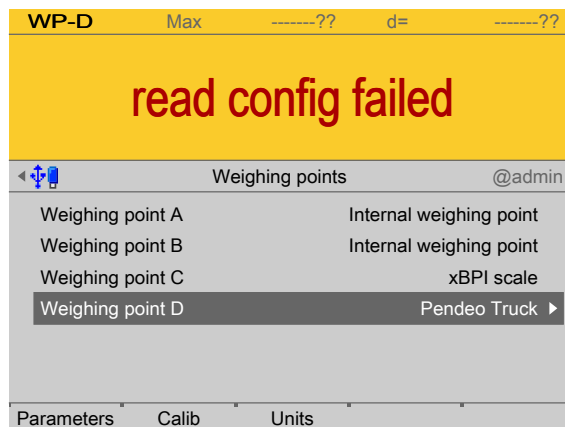

4.7.7.1 Interface (serial)

In this menu item, the parameters of the serial interface of the digital weighbridge load cell **Pendeo® Truck** are configured.

Accessible via **MENU** - [Operating] - [System setup] - [Weighing points] - [Weighing point x] - [Interface] .

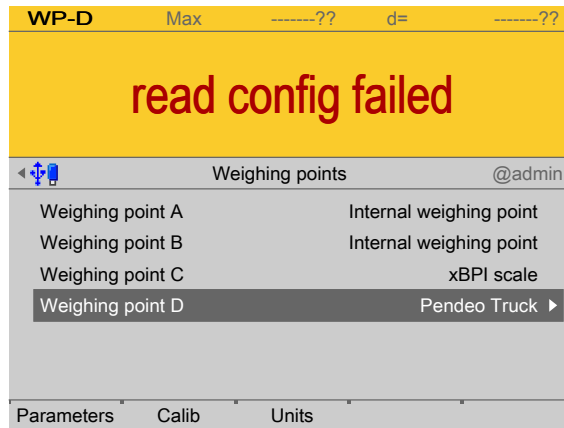

1. In this case: Select and confirm [Weighing point D] with [Pendeo Truck].
 ▷ A selection window opens.

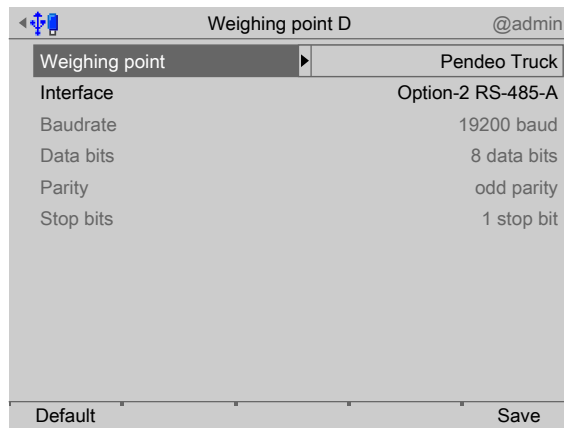

Inactive parameters are grayed out.

2. Select and confirm the individual parameters.

[Interface]

Serial interfaces.

Selection: not assigned, Built-in RS-232, Built-in RS-485, Option-x RS-485-A, Option-x RS-485-B

In this case: Select [Option-2 RS-485-A].

[Default] soft key

Settings are reset to factory settings.

3. Press the [Save] soft key to save the settings.

4.7.7.2 Parameters

In this menu item (under **Calib**), the parameters of the digital weighbridge load cell **Pendeo® Truck** are configured.

Accessible via **MENU** - [Operating] - [System setup] - [Weighing points] - [Weighing point x] - [Parameters] .

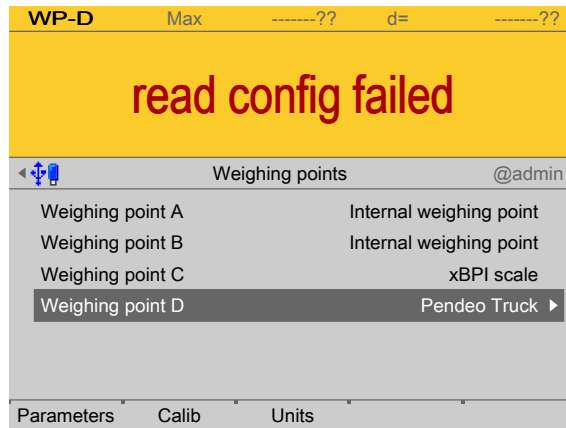

1. In this case: Select [Weighing point D] with [Pendeo Truck] and press the [Parameters] soft key..
 ▷ A selection window opens.

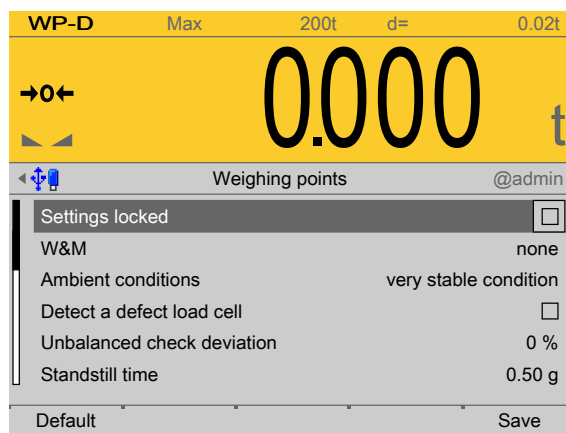

2. Select and confirm the individual parameters.

[Settings locked]

The weighing point settings and assignment can only be viewed as if the corresponding CAL switch were closed; see Chapter [2.7.1](#).

[W&M]

Setting for operation in legal metrology.

Selection: [None], OIML, NTEP (for USA) or NSC (for Australia), see Chapter [4.7.1.1.1](#).

[Ambient conditions]

This parameter is used to define the ambient conditions of the scale.

Selection: very stable condition, Stable condition, Unstable condition, Very unstable condition

[Detect a defective load cell]

Select and confirm these parameters if the maximum simulation of a faulty load cell is to be performed automatically. A warning symbol is displayed as long as the load cell is being simulated.

[Unbalanced check deviation]

The plausibility check is activated when the average deviation is > 0%.

The average deviation of the individual load cells is calculated. Monitoring is indicated via symbol above the weight unit.

Setting range: 0 to 100%.

[Standstill time]

The parameters [Standstill time] and [Standstill range] are used to define the standstill of the scale (stable balance).

The [Standstill time] parameter is entered in seconds. The permitted range is: 0.00...2 s.

The time can be entered from 0.00 to 2.00 seconds, but always makes up at least one measurement time.

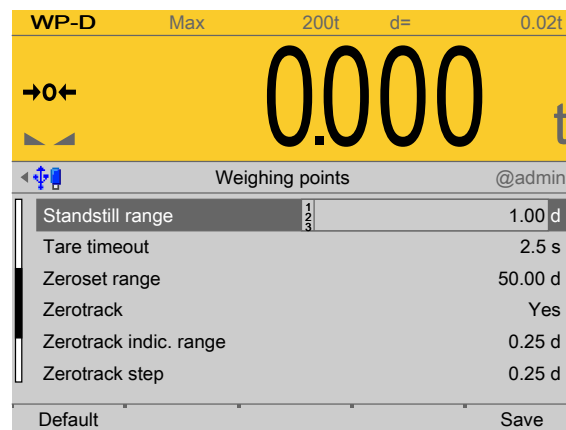

[Standstill range]

As long as the weight fluctuations remain within this range, the device is determined to be stable.

The [Standstill range] parameter is entered in "d". The permitted range is: 0.01...10.00 d.

For use in legal metrology, ≤ 1 d must be selected.

[Tare timeout]

Timeout for a tare/zeroset command that cannot be executed (e.g. due to mechanical instability of the scale, incorrect filter setting, resolution too high, standstill condition too strict).

This parameter is given in seconds. The permitted range is: 0.0...[2.5]...25 s.

At 0.0 s taring is only carried out when the scale is already stable.

[Zeroset range]

Determine a \pm range around the zero point determined by the dead load during calibration; within this range

- the displayed gross weight can be set to zero by pressing the zero-setting key (or by a corresponding external command), and
- automatic zero tracking is active.

Setting range: 0.00...10000.00 d

For use in legal metrology a value $\leq 2\%$ of the max must be entered, example: 60 d for 3000 e of Class III.

[Zerotrack]

The zero display is automatically maintained within set limits.

Selection: No/Yes

When [No] is selected, the next three parameters are not shown.

When [Yes] is selected, values for the next three parameters must be entered.

[Zerotrack indic. range]

Indication range within which automatic zerotrack compensates for deviations.

Setting range: 0.25...10000.00 d

For use in legal metrology a value of <0.5 d must be entered.

[Zerotrack step]

If a weight change exceeds the adjusted value, automatic tracking does not function any more.

Setting range for automatic tracking increments: 0.25...10 d

For use in legal metrology a value of ≤ 0.5 d must be entered.

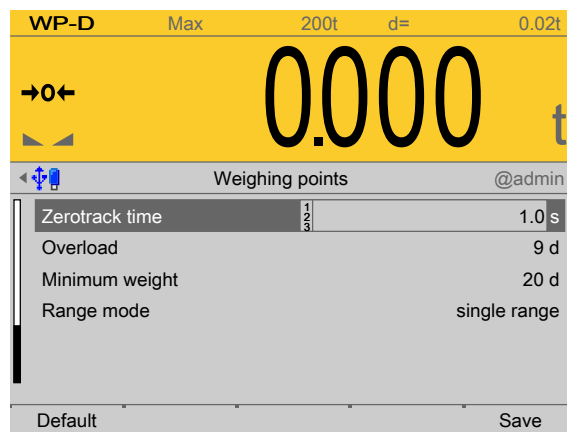
**[Zerotrack time]**

Time interval for automatic zerotrack.

Setting range: 0.1...25 s

For use in legal metrology a value of 1 s must be entered.

[Overload]

Weighing range above the maximum capacity (Max) without error message.

Setting range: 0...9999999 d

For use in legal metrology a value of max. 9 d = e must be set.

[Min. weight]

Minimum weight at which a print command can be triggered.

Setting range: 0...9999999 d

For use in legal metrology a value of at least 20 d must be set.

[Range mode]

Selection: single range, multi-range, multi-interval

For range selection for scales and settings, refer to Chapter [4.7.1.1.2](#) and [4.7.1.1.3](#)

[Default] soft key

Settings are reset to factory settings.

3. Press the [Save] soft key to save the settings.

4.7.7.3 Calib

In this menu item, calibration is performed for the digital weighbridge load cell **Pendeo® Truck**.

- [Quick install with search load cells and set dead load], see Chapter [4.7.7.3.1](#).
- [Search for connected load cells], see Chapter [4.7.7.3.2](#).
- [View and assign load cells], see Chapter [4.7.7.3.3](#).
- [Calibrate the scale] (load cells), see Chapter [4.7.7.3.4](#).
 - [New], see Chapter [4.7.7.3.4.1](#).
 - [Modify], see Chapter [4.7.7.3.4.2](#).
- [Assign load cell name], see Chapter [4.7.7.3.5](#).
- [Service function for load cells], see Chapter [4.7.7.3.6](#).
- [Corner correction], see Chapter [4.7.7.3.7](#).

During calibration, no data is changed in the digital load cells. The calibration data and parameters are saved in the device. The unique serial numbers of the connected load cells are monitored.

For the calibration the following order must be followed:

- Search for load cells and set dead load, see Chapter [4.7.7.3.1](#) or search for load cells only, see Chapter [4.7.7.3.2](#).
- Assign load cells, see Chapter [4.7.7.3.3](#).
- Recalibrate: Maximum capacity with weight unit, scale interval, dead load, calibration weight, see Chapter [4.7.7.3.4.1](#).
- Perform a corner correction if necessary; see Chapter [4.7.7.3.7](#).

Note:

For further information about calibrating weighing points, see Chapter [4.7.1](#).

Accessible via **MENU** - [Operating] - [System setup] - [Weighing points] - [Weighing point x] - [Calib] .

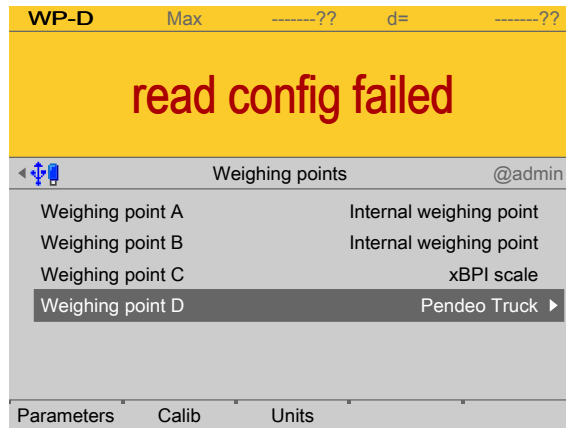

- ▶ In this case: Select [Weighing point D] with [Pendeo Truck] and press the [Calib] soft key.
- ▷ The Pendeo setup menu opens.

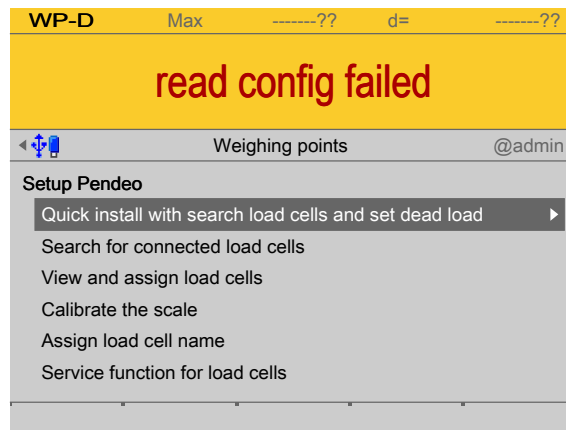

4.7.7.3.1 Quick install with search load cells and set dead load

In this menu item (under **Calib**), quick install with search and setting of the dead load is performed for the digital weighbridge load cell **Pendeo® Truck**.

Accessible via **MENU** - [Operating] - [System setup] - [Weighing points] - [Weighing point x] - [Calib] - [Quick install with search load cells and set dead load].

1. Unload the scale.

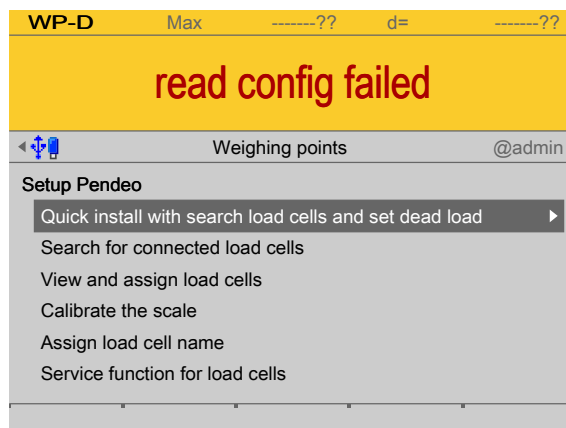

2. Select and confirm [Quick install with search load cells and set dead load].
 - ▷ A prompt window appears.

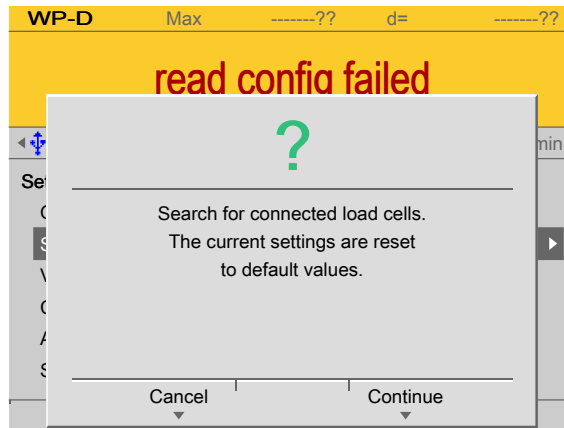

3. Press the [Continue] soft key to start the search.
Press the [Cancel] soft key to return to the Pendeo setup menu.

▷ An input window opens.

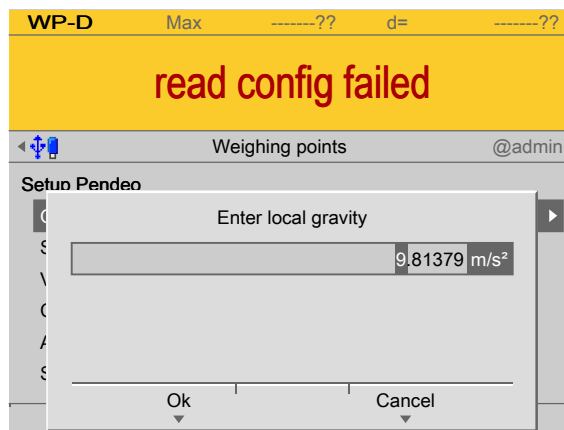

4. If necessary, change the present value and press the [OK] soft key to confirm the entry.

Press the [Cancel] soft key to return to the Pendeo setup menu.

▷ The search is started and the dead load is set. The Pendeo setup menu appears after this is complete.

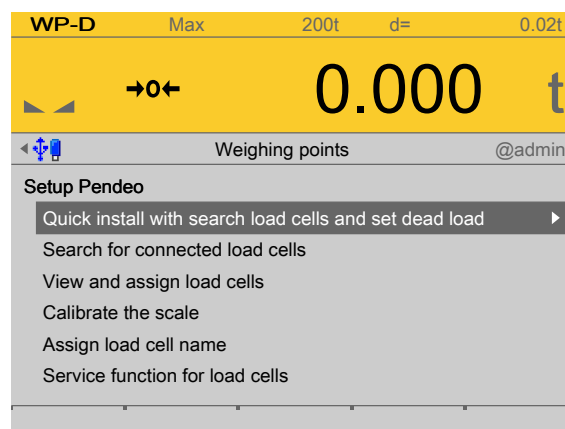

4.7.7.3.2 Search for connected load cells

In this menu item (under **Calib**), a search is performed for connected load cells of the digital weighbridge load cell **Pendeo® Truck**.

Accessible via **MENU** – [Operating] - [System setup] - [Weighing points] - [Weighing point x] - [Calib] - [Search for connected load cells].

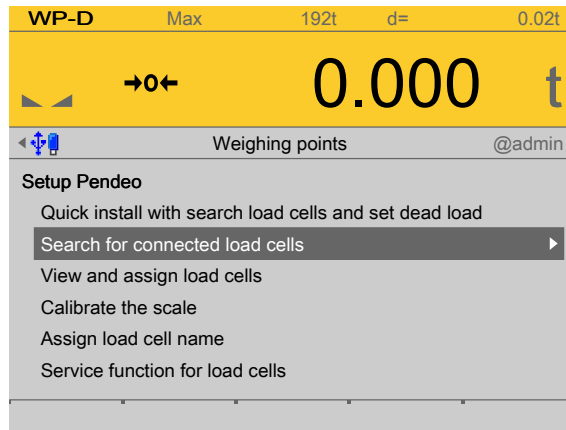

1. Select and confirm [Search for connected load cells].

▷ A prompt window opens.

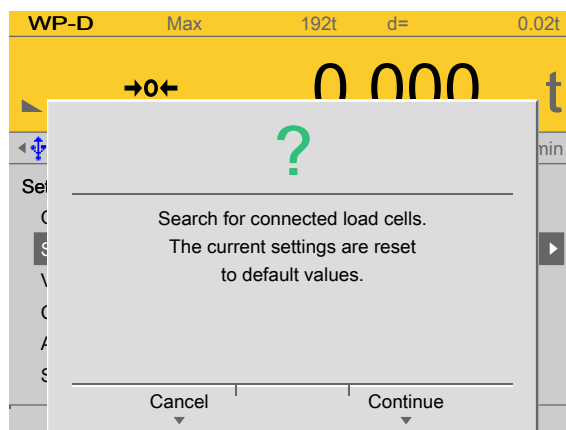

2. Press the [Continue] soft key to start the search.

Press the [Cancel] soft key to return to the Pendeo setup menu.

▷ The search is started.

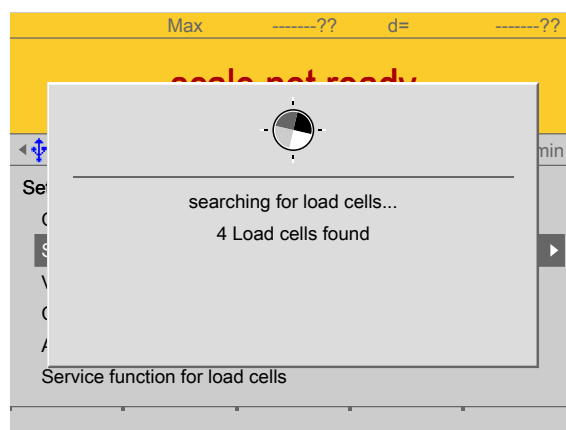

The Pendeo setup menu appears after this is complete.

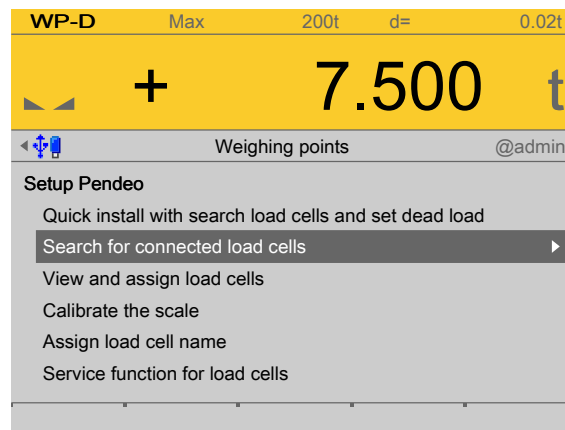

4.7.7.3.3 View and assign load cells

In this menu item (under **Calib**), the load cell data of the digital weighbridge load cell **Pendeo® Truck** is displayed and assigned to the individual installation locations.

- [Info] (display load cell data), see Chapter [4.7.7.3.3.1](#).
- [Assign] (installation locations), see Chapter [4.7.7.3.3.2](#).

Accessible via **MENU** - [Operating] - [System setup] - [Weighing points] - [Weighing point x] - [Calib] - [View and assign load cells] .

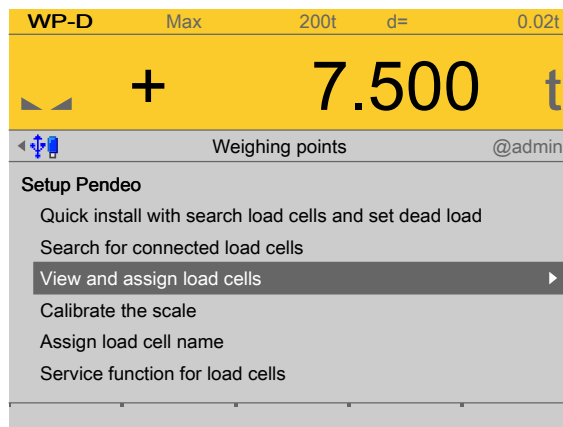

- ▶ Select and confirm [View and assign load cells].
 - ▷ The load cells are displayed with their item number, serial number, and load.

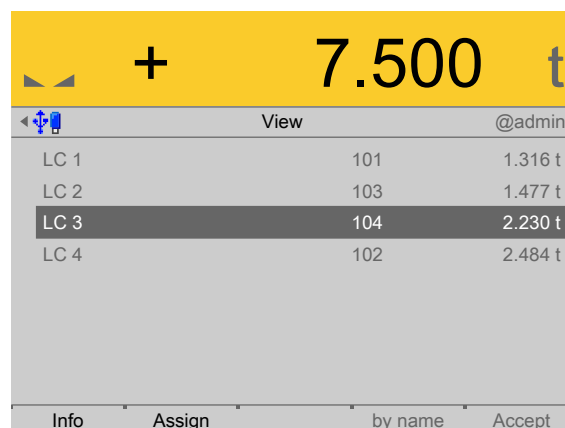

4.7.7.3.1 Info (display load cell data)

In this menu item (under **View and assign load cells**), the load cell data of the digital weighbridge load cell **Pendeo® Truck** is displayed.

Accessible via **MENU** - [Operating] - [System setup] - [Weighing points] - [Weighing point x] - [Calib] - [View and assign load cells] - [Info] .

+ 7.500 t		
	View	@admin
LC 1	101	1.316 t
LC 2	103	1.477 t
LC 3	104	2.230 t
LC 4	102	2.484 t

Info Assign by name Accept

The load cells are displayed with their item number, serial number, and load.

1. Select the desired load cell and press the [Info] soft key.

Note:

If load cell names have been assigned (see Chapter [4.7.7.3.5](#)), the view can be switched with the [by name] soft key.

- ▷ The load cell data is displayed.

+ 7.500 t		
	Load cell info	@admin
Model name		PR6224/50tC3
Software version		1.00.04
LC serial number		104
Emax		50.0 t
n		3000 e
Y		14000
Z		3000
Overload		75.0 t
Overload counter		0

2. Press **EXIT** to return to the previous window.

4.7.7.3.2 Assign (installation locations)

In this menu item (under **View and assign load cells**), the load cells (serial numbers) of the digital weighbridge load cell **Pendeo® Truck** are assigned to the installation locations.

This is important for correcting the dead load (distribution to the individual load cells), for corner correction and in the event of load cell replacement.

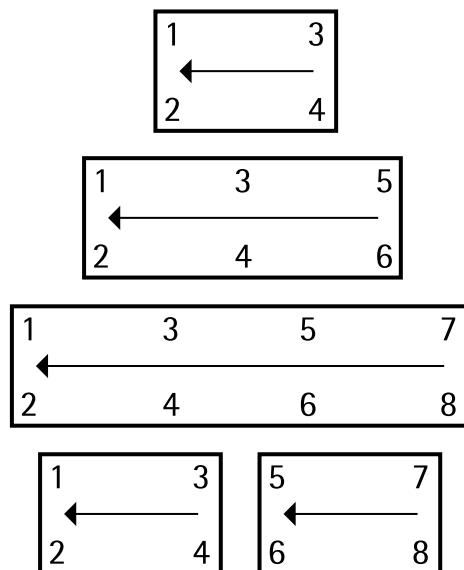

Example of a possible allocation.

Note:

The assignment from the installation should be documented in the case of load cells being replaced.

Accessible via **MENU** - [Operating] - [System setup] - [Weighing points] - [Weighing point x] - [Calib] - [View and assign load cells] - [Assign] .

1. Unload the scale.

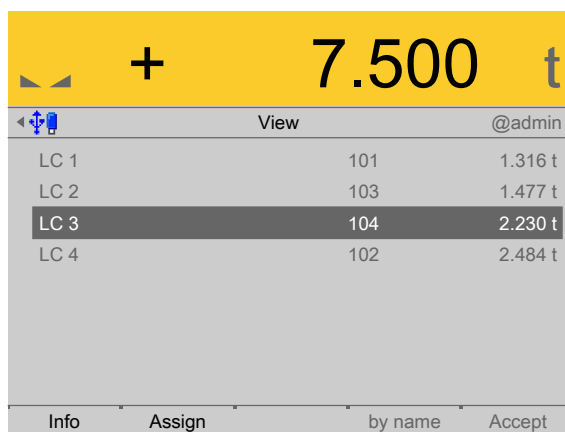

2. Press the [Assign] soft key.
 - ▷ A prompt is shown.

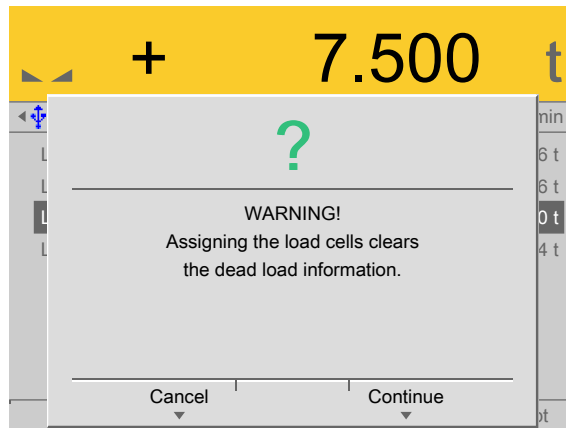

3. Press the [Continue] soft key.

The load cells are assigned by placing minimum weights on the scale.

Weighing points			@admin
LC 1	101	4.176 t	1
LC 2	103	1.643 t	0
LC 3	104	3.698 t	0
LC 4	102	3.619 t	0

4. Place the weight on the corner/load cell that will later be assigned no. 1.
 - ▷ As soon as the device detects the weight change, the corresponding line is selected.
5. Press the [Accept] soft key.
 - ▷ The future LC no. is shown at the far right of the line.
6. Remove the calibration weight.
7. Repeat these steps for load cells 2 to 4.
8. Press the [Save] soft key to save the new assignment.
 - ▷ The Pendeo setup menu opens.

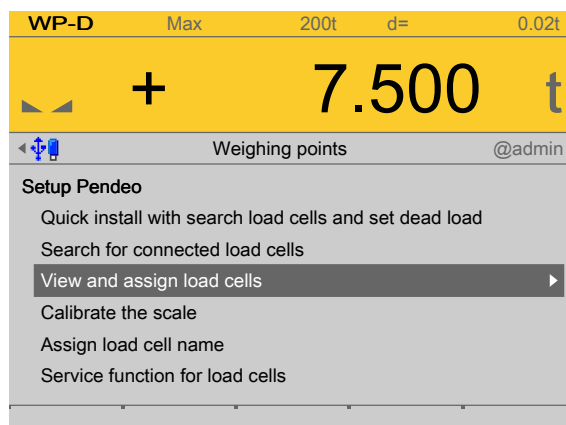

9. Select and confirm [View and assign load cells].
 - ▷ The new assignment will be displayed.

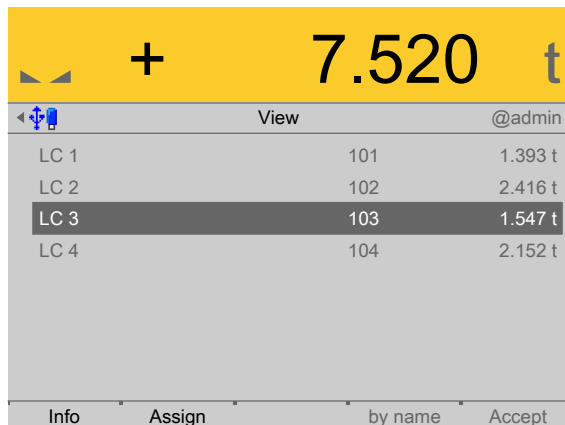

View		
	ID	Weight
LC 1	101	1.393 t
LC 2	102	2.416 t
LC 3	103	1.547 t
LC 4	104	2.152 t

10. Check the corner load (dead load) if necessary; see Chapter [4.7.7.3.7](#).
11. Press **EXIT** to return to the previous window.

4.7.7.3.4 Calibrate the scale

In this menu item (under **Calib**), the load cells of the digital weighbridge load cell **Pendeo® Truck** are calibrated.

- [New], see Chapter [4.7.7.3.4.1](#).
- [Modify] (for minor changes), see Chapter [4.7.7.3.4.2](#).
- Dead load (correction), see Chapter [4.7.7.3.4.3](#).

Note:

The menu item [Modify] is only used for minor changes (e.g. changing the dead load/preload). Otherwise, the menu item **[New]** should be selected.

Accessible via **MENU** – [Operating] – [System setup] – [Weighing points] – [Weighing point x] – [Calib] – [Calibrate the scale].

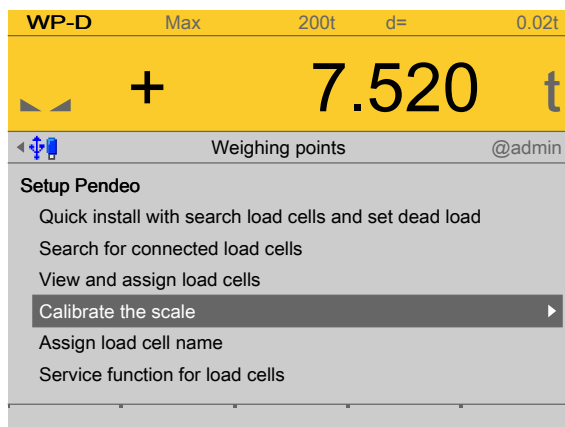

WP-D Max 200t d= 0.02t		
Weighing points		
Setup Pendeo		
Quick install with search load cells and set dead load		
Search for connected load cells		
View and assign load cells		
Calibrate the scale ▶		
Assign load cell name		
Service function for load cells		

- ▶ Select and confirm [Calibrate the scale].
 - ▷ The data from the last calibration is displayed.

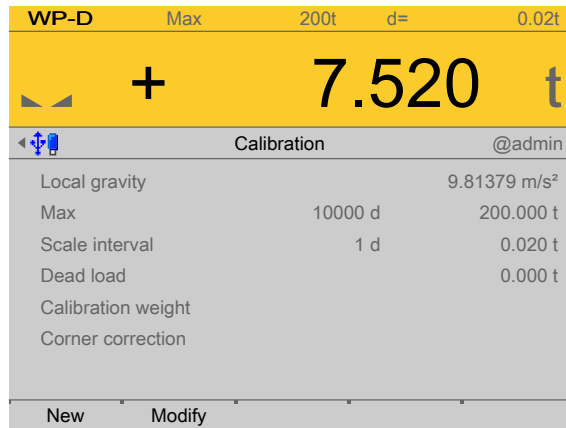

- The [New] soft key starts a new calibration, see Chapter [4.7.7.3.4.1](#).
- The [Modify] soft key (only use for minor changes!) changes an existing calibration, see Chapter [4.7.7.3.4.2](#).

4.7.7.3.4.1 New

In this menu item (under **Calibrate the scale**), a new calibration of the digital weighbridge load cell **Pendeo® Truck** is performed and configured.

Example data:

- Maximum capacity of a load cell: $E_{\max} = 50 \text{ t}$
- Number of load cells: 4
- Max: 200.000 t
- Scale interval: 0.020 t
- Dead load: Empty weight
- Calibration weight: 11.000 t

Accessible via **MENU** - [Operating] - [System setup] - [Weighing points] - [Weighing point x] - [Calib] - [Calibrate the scale] - [New] .

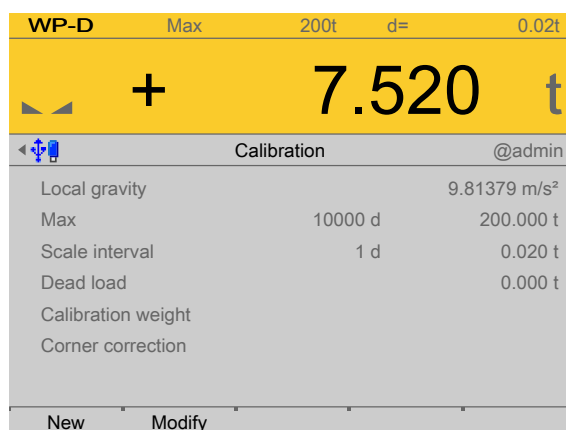

The data from the last calibration is displayed.

1. Press the [New] soft key.

Note:

The menu item [Modify] is only used for minor changes (e.g. changing the dead load/preload). Otherwise, the menu item [**New**] should be selected.

- ▷ A prompt window appears.

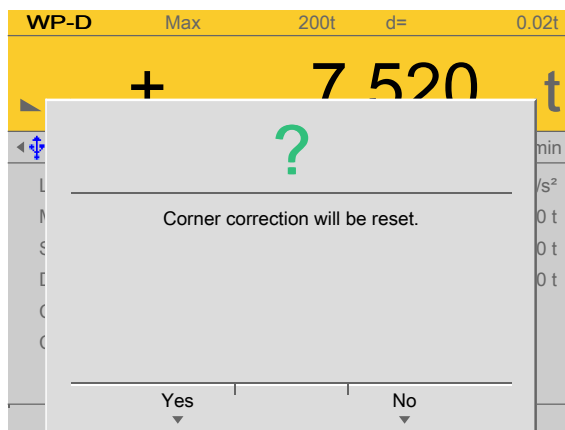

2. Press the [Yes] soft key.

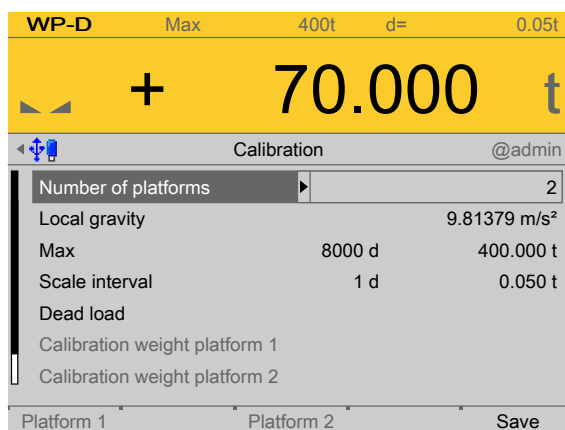
**Note:**

The parameter [Number of platforms] only appears with 8 load cells. In this case: Example for 2 platforms.

3. Select and confirm [Number of platforms].

WP-D Max 200t d= 0.02t

+ 7.520 t

Calibration @admin

Local gravity	1	9.81379 m/s ²
Max	10000 d	200.000 t
Scale interval	1 d	0.020 t
Dead load		
Calibration weight		
Corner correction		

Platform 1 Save

- Select [Local gravity], change if necessary, and confirm.

WP-D Max 200t d= 0.02t

+ 7.500 t

Calibration @admin

Local gravity		9.81379 m/s ²
Max	10000 d	200.000 t
Scale interval	1 d	0.020 t
Dead load		
Calibration weight		
Corner correction		

Platform 1 Save

- Enter [Max] (maximum capacity) with decimal places (in this example: 200.000 t).
- Press the  key (2x) to select the weight unit.
- Confirm the entries.

▷ The confirmation is displayed with "setting Max...".

The weight unit is taken from [Max]. The number of digits behind the decimal point is also automatically determined when [Max] is entered.

WP-D Max 200t d= 0.02t

+ 7.520 t

Calibration @admin

Local gravity		9.81379 m/s ²
Max	10000 d	200.000 t
Scale interval	1 d	0.020 t
Dead load		
Calibration weight		
Corner correction		

Platform 1 Save

- Select the [scale interval] (1 d).
 - ▷ The scale interval (d) is calculated, based on the maximum weight value.
- Confirm the entries.

- ▷ The confirmation is displayed with "setting scale interval..."

To use the empty scale (deck installed on a vehicle scale, no load) as dead load (normal case):

10. Do not load scale.

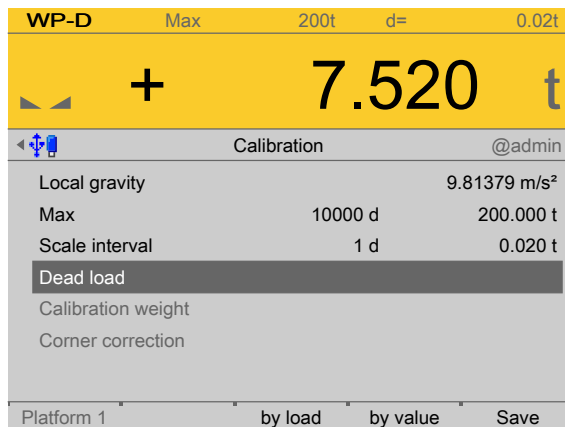

11. Select [Dead load] and press the [by load] soft key.

Note:

Once the dead load is known, the value can be overwritten by pressing the [by value] soft key.

12. Confirm the entries.

- ▷ The confirmation is displayed with "Setting dead load..."

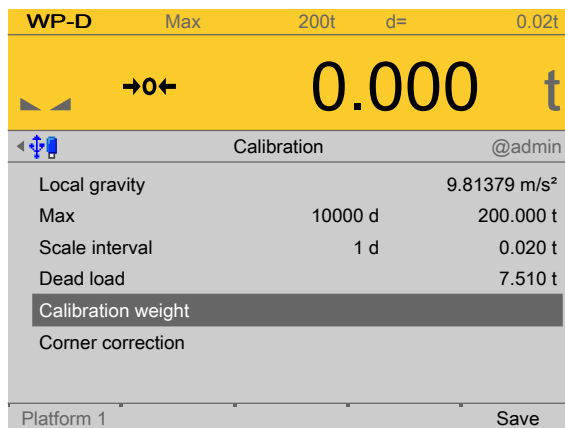

13. Select and confirm [Calibration weight].

- ▷ An input window opens.

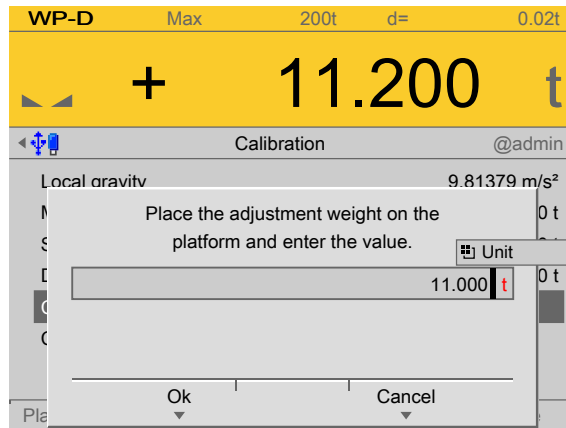

14. Place calibration weight on the center of the scale and enter the weight value.
15. Press the [OK] soft key.
16. Remove the calibration weight.
 - ▷ The corner load (dead load set to zero) is displayed.

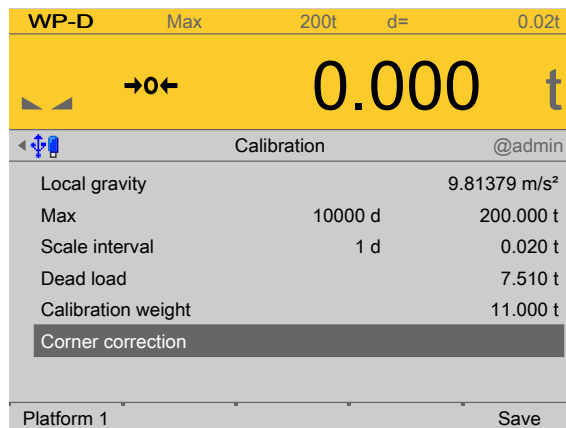

17. Perform a corner correction if necessary; see Chapter [4.7.7.3.7](#).
18. Press the [Save] soft key to save the calibration.

4.7.7.3.4.2 Modify

In this menu item (under **Calibrate the scale**), changes are made to an existing calibration of the digital truck scale load cell **Pendeo® Truck**.

- For parameters (local gravity, maximum capacity, scale interval, calibration weight), see Chapter [4.7.7.3.4.1](#).
- Dead load (subsequent correction), see Chapter [4.7.7.3.4.3](#).
- Corner correction, see Chapter [4.7.7.3.7](#)

Accessible via **MENU** - [Operating] - [System setup] - [Weighing points] - [Weighing point x] - [Calib] - [Calibrate the scale] - [Modify].

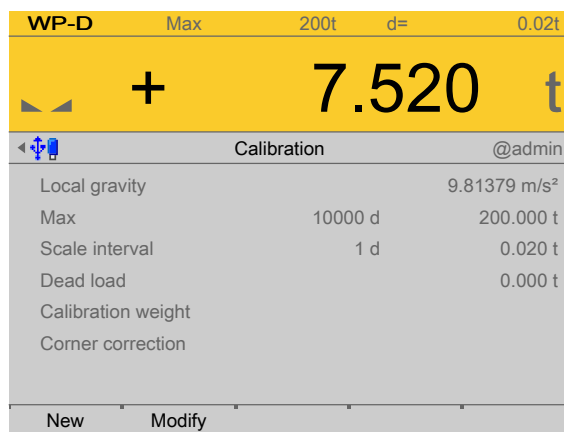

The data from the last calibration is displayed.

1. Press the [Modify] soft key.

Note:

The menu item [Modify] is only used for minor changes (e.g. changing the dead load/preload). Otherwise, the menu item [**New**] should be selected.

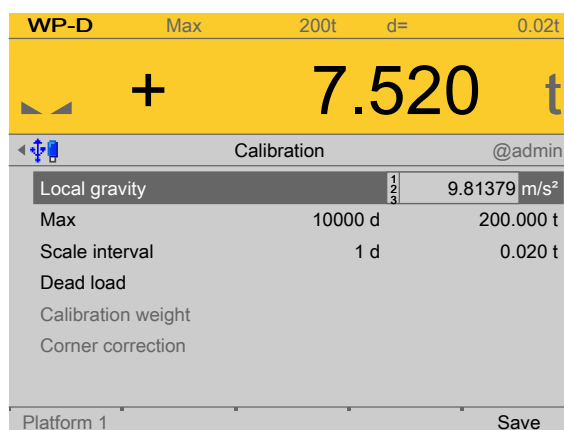

2. Select the individual parameters and confirm.
For description and settings of the parameters, refer to Chapter [4.7.7.3.4.1](#).
3. Press the [Save] soft key to save the calibration.

4.7.7.3.4.3 Dead load (correction)

In this menu item, the dead load is modified for the digital weighbridge load cell **Pendeo® Truck**.

If the platform weight changes by an amount that is higher than the zero range, e.g., due to dead load reduction, dead load increase, or mechanical changes, the functions for automatic zero tracking and manual zero setting no longer work.

If the entire zeroset range is already utilized, you can still correct the dead load without affecting other calibration data/parameters.

Accessible via **MENU** - [Operating] - [System setup] - [Weighing points] - [Weighing point x] - [Calib] - [Calibrate the scale] - [Modify] - [Dead load] .

1. The scale must be empty (deck installed on a vehicle scale, no load).

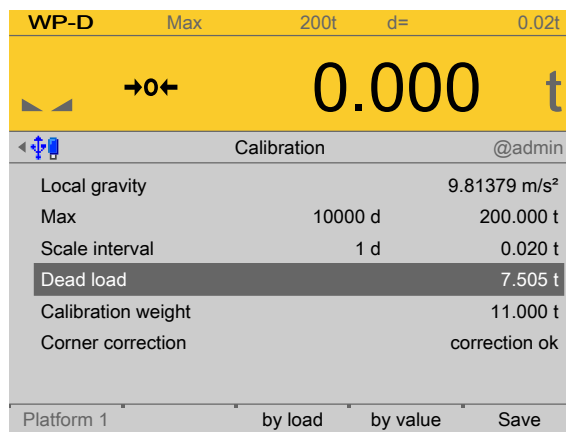

2. Select and confirm [Dead load].
3. Confirm the dead load (Σ corner load).
4. Check the corner load; see Chapter [4.7.7.3.7](#).
5. Perform a corner correction if necessary; see Chapter [4.7.7.3.7](#).
6. Press the [Save] soft key to save the current dead load.

4.7.7.3.5 Assign load cell name

In this menu item (under **Calib**), each load cell of the digital weighbridge load cell **Pendeo® Truck** can be given a name.

Accessible via **MENU** - [Operating] - [System setup] - [Weighing points] - [Weighing point x] - [Calib] - [Assign load cell name] .

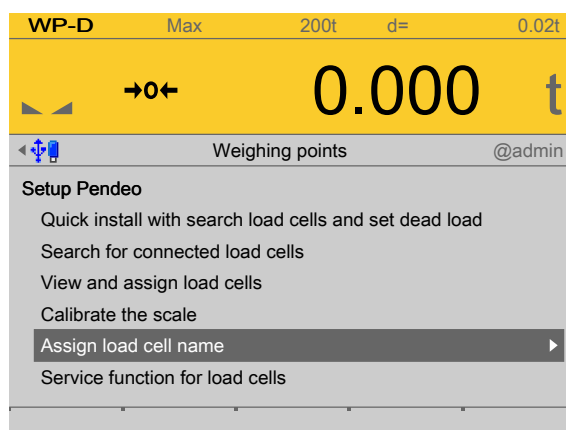

1. Select and confirm [Assign load cell name].

▷ An input window opens.

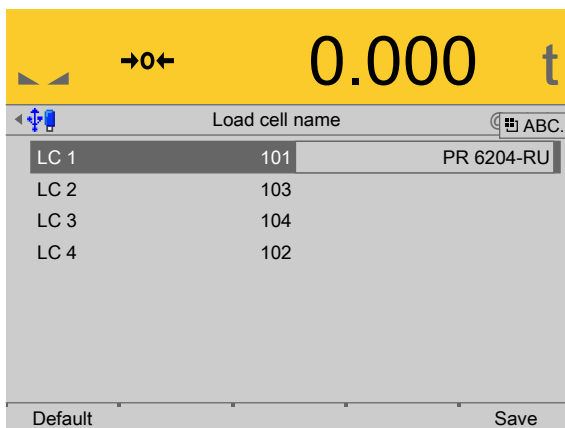

2. Select the load cells in succession, enter the name using the keyboard and confirm.
3. Press the [Save] soft key to save the entry.

4.7.7.3.6 Service function for load cells

In this menu item (under **Calib**), faulty load cells of the digital weighbridge load cell **Pendeo® Truck** can be deactivated and replacement load cells activated.

Accessible via **MENU** – [Operating] – [System setup] – [Weighing points] – [Weighing point x] – [Calib] – [Service function for load cells] .

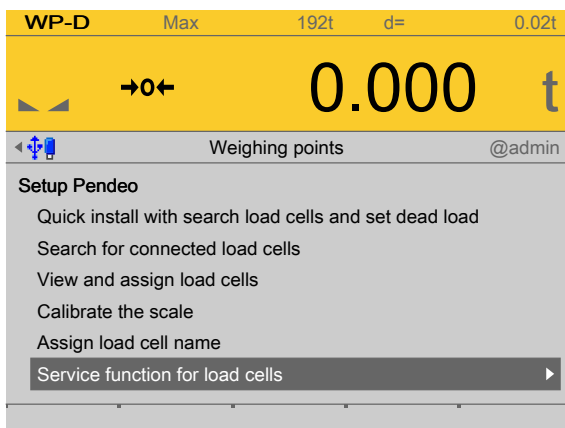

1. Select and confirm [Service function for load cells].
- ▷ The service window opens.

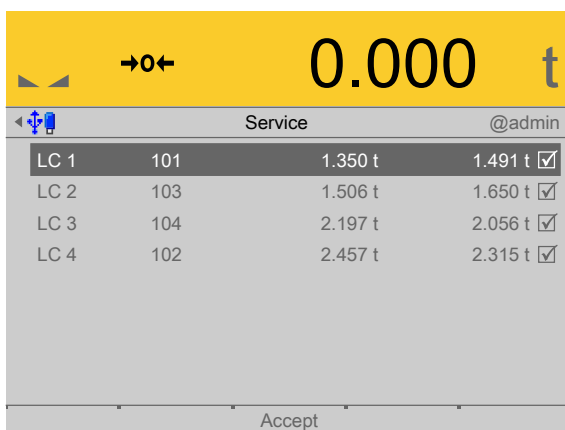

Item number, serial number, dead load, and current load of connected load cells are displayed.

Deactivating the load cell

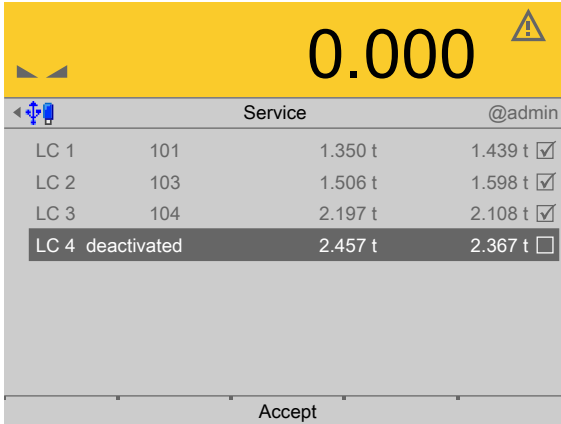

		0.000		⚠
	Service			@admin
LC 1	101	1.350 t	1.439 t	<input checked="" type="checkbox"/>
LC 2	103	1.506 t	1.598 t	<input checked="" type="checkbox"/>
LC 3	104	2.197 t	2.108 t	<input checked="" type="checkbox"/>
LC 4	deactivated	2.457 t	2.367 t	<input type="checkbox"/>

Accept

- Select the faulty load cell and confirm to deactivate the cell.
 - ▷ The warning symbol replaces the weight unit.
- Press the [Accept] soft key.
 - ▷ The simulation of the deactivated load cell is started.

Note:

Trucks should only be allowed to move onto the center of the weighing platform, in order to distribute the weight evenly.

Activating the load cell

After inserting and connecting the new load cell:

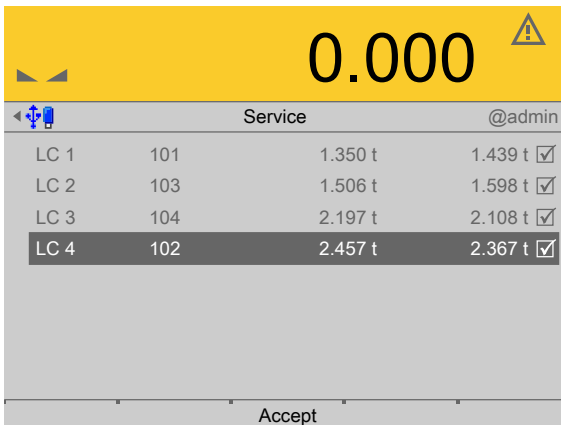

		0.000		⚠
	Service			@admin
LC 1	101	1.350 t	1.439 t	<input checked="" type="checkbox"/>
LC 2	103	1.506 t	1.598 t	<input checked="" type="checkbox"/>
LC 3	104	2.197 t	2.108 t	<input checked="" type="checkbox"/>
LC 4	102	2.457 t	2.367 t	<input checked="" type="checkbox"/>

Accept

- Select and confirm the deactivated load cell.
- Press the [Accept] soft key.
 - ▷ A search is initiated and only then will the new load cell be detected.

Service			
LC 1	101	1.350 t	1.439 t <input checked="" type="checkbox"/>
LC 2	103	1.506 t	1.598 t <input checked="" type="checkbox"/>
LC 3	104	2.197 t	2.108 t <input checked="" type="checkbox"/>
LC 4	107	2.457 t	2.367 t <input checked="" type="checkbox"/>

Accept

4.7.7.3.7 Corner correction

In this menu item (under **Calib**), corner correction is performed for the digital weighbridge load cell **Pendeo® Truck**.

Checking the corner load (dead load):

After assignment (see Chapter 4.7.7.3.3) and calibration (see Chapter 4.7.7.3.4), the position of the load cells is clearly defined.

Mechanical corner correction:

A mechanical corner correction has to be carried out if the load is not evenly distributed over the load cells, e.g. if the platform is wobbling.

The dead load on the load cells can be corrected using shims. If two coupled platforms are connected, corner load checking or installation of shims for the platforms must be performed independently.

Accessible via **MENU** - [Operating] - [System setup] - [Weighing points] - [Weighing point x] - [Calib] - [View and assign load cells] .

View			
LC 1	101	1.316 t	
LC 2	103	1.477 t	
LC 3	104	2.230 t	
LC 4	102	2.484 t	

Info Assign by name Accept

The load cells are displayed with their item number, serial number, and load.

In this example, the load on a load cell does not need to be increased by a shim. A fine calibration can be done by subsequent software corner correction.

Software corner correction:

If the corners are loaded in succession, the same value should be displayed on the device at all times. An excessive deviation almost always means that the scale is tilted or indicates load cell force shunts.

If the signal deviations cannot be resolved by carefully leveling the scale, the software must be calibrated.

Accessible via **MENU** - [Operating] - [System setup] - [Weighing points] - [Weighing point x] - [Calib] - [Modify] - [Corner correction] .

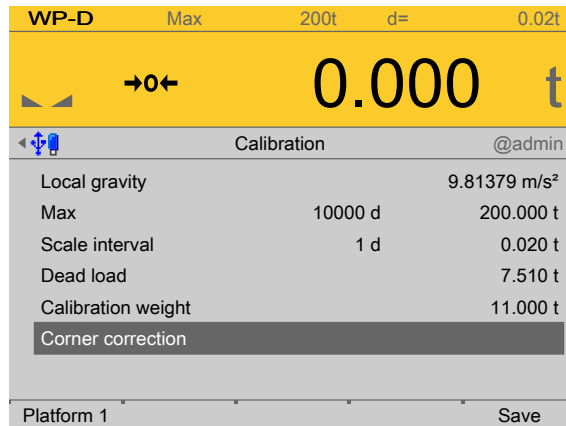

1. Select [Corner correction].
2. Press the [Platform 1] soft key.
3. Place the calibration weight on a corner.

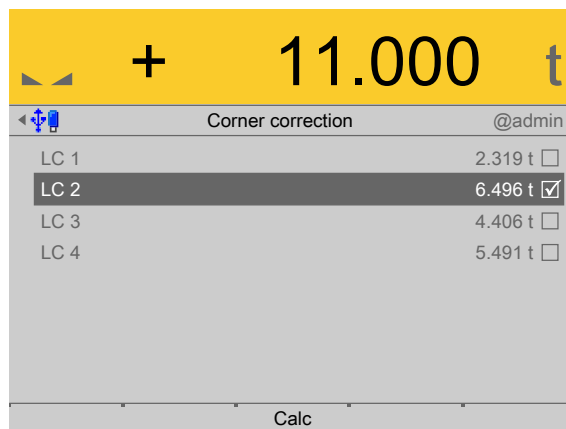

4. Position (here: LC 2) is highlighted.
5. Confirm position.
6. Remove the calibration weight.
7. Repeat steps 1 to 6 for the remaining load cells.

You are free to choose any desired order.

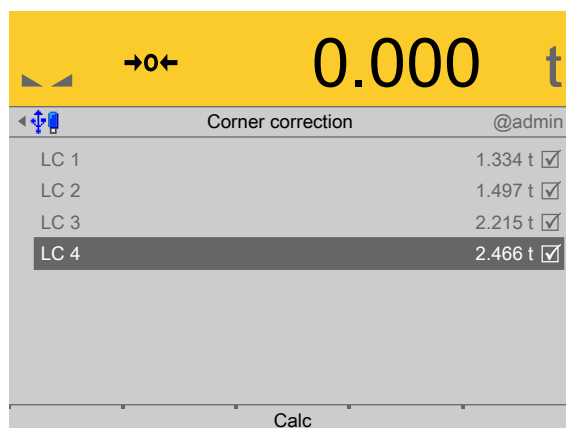

8. Once all load cells have been loaded one time, press the [Calculate] soft key to perform corner correction.
 - ▷ The total weight remains unchanged. Only the effect of the individual load cells is corrected.

When corner correction is completed, it is marked with [Correction ok].

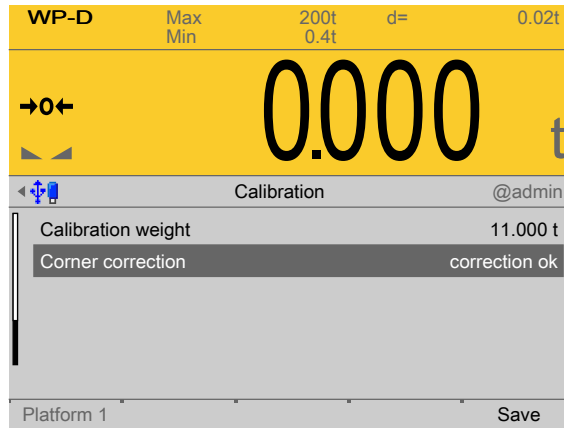

9. Press the [Save] soft key to save the corner correction.

4.7.7.4 Units

In this menu item, additional weight units for the display and the display accuracy of the digital weighbridge load cell **Pendeo® Truck** are configured.

Descriptions and settings can be found in the [Internal weighing point] menu; see Chapter [4.7.1.3](#).

Accessible via **MENU** - [Operating] - [System setup] - [Weighing points] - [Weighing point x] - [Units].

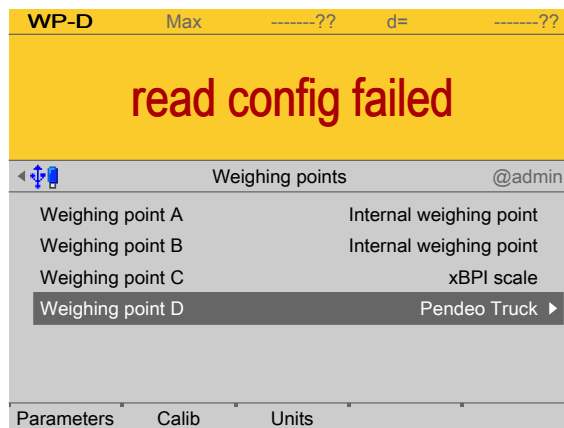

- ▶ In this case: Select [Weighing point D] with [Pendeo Truck] and press the [Units] soft key.

Descriptions and settings can be found in the [Internal weighing point] menu; see Chapter [4.7.1.3](#).

4.7.8 Pendeo Process

In this menu item (under **Weighing points**), the digital precision pressure load cell **Pendeo® Process** is assigned to a logical weighing point and configured.

- [Interface] (serial), see Chapter [4.7.8.1](#).

- [Parameters], see Chapter [4.7.8.2](#).
- [Calib], see Chapter [4.7.8.3](#).
- [Units] (display accuracy), see Chapter [4.7.8.4](#).

The digital load cells have been calibrated at the factory based on the acceleration of gravity at Hamburg (9.81379 m/s^2). The calibration data in the load cells are invariable. The calibration data for the gravity acceleration at the place of installation can be adapted only in the device and protected against overwriting (see Chapter [2.7](#)). With applications for use in legal metrology, the legal requirements and the conditions given on the test/ approval certificate must be taken into account when selecting the settings.

Accessible via **MENU** - [Operating] - [System setup] - [Weighing points] - [Weighing point x] - [Weighing point] - [Pendeo Process] .

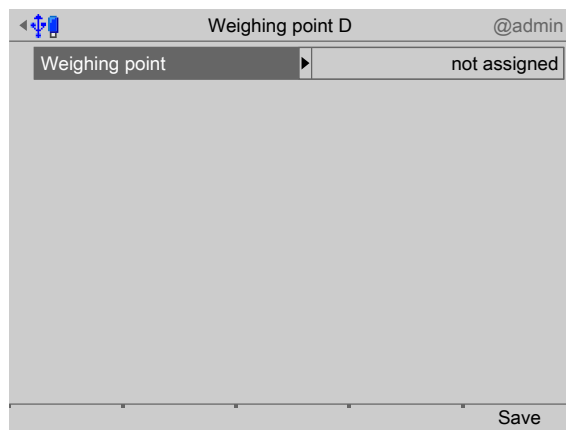

1. Confirm [Weighing point].

- ▷ A selection window opens.

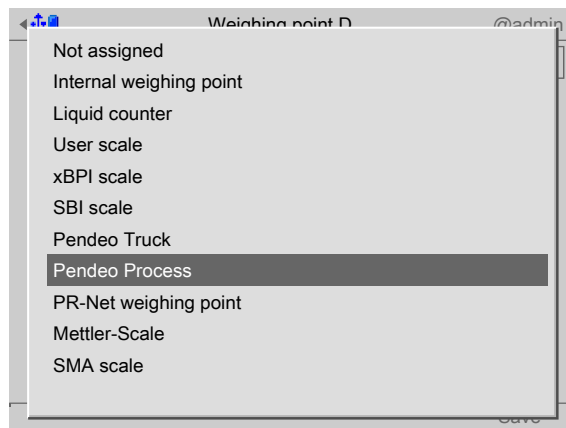

2. Select and confirm [Pendeo Process].

3. Press the [Save] soft key to save the settings.

- ▷ The weighing electronics are now assigned to the weighing point.

If a scale has not yet been connected, the message "scale not ready" appears.

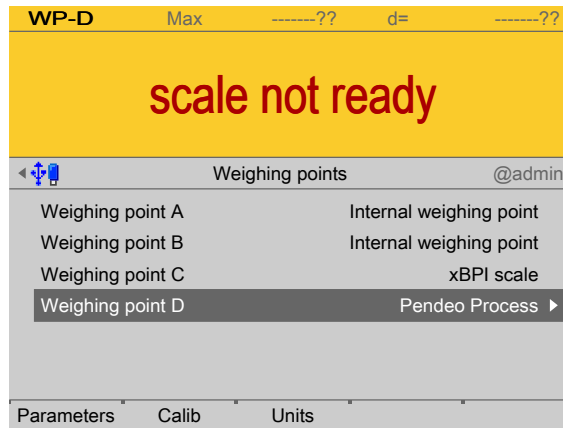

4.7.8.1 Interface (serial)

In this menu item, the parameters of the serial interface of the digital precision pressure load cell **Pendeo® Process** are configured.

Accessible via **MENU** - [Operating] - [System setup] - [Weighing points] - [Weighing point x] - [Interface] .

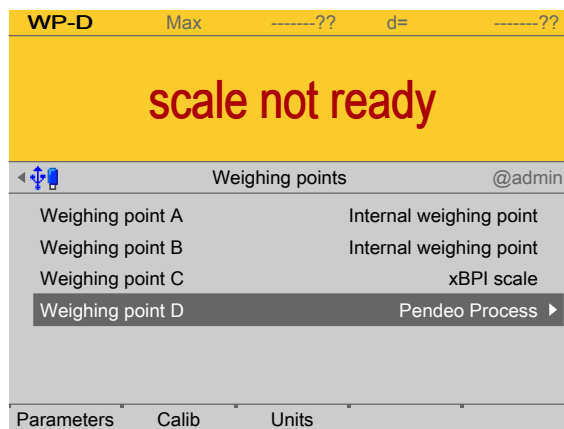

1. In this case: Select and confirm [Weighing point D] with [Pendeo Process].
 ▷ A selection window opens.

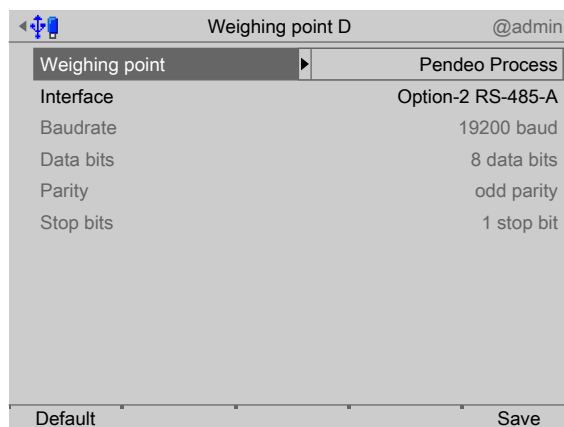

Inactive parameters are grayed out.

2. Select and confirm the individual parameters.

[Interface]

Serial interfaces.

Selection: not assigned, Built-in RS-232, Built-in RS-485, Option-x RS-485-A, Option-x RS-485-B

In this case: Select [Option-2 RS-485-A].

[Default] soft key

Settings are reset to factory settings.

3. Press the **[Save]** soft key to save the settings.

4.7.8.2 Parameters

In this menu item (under **Calib**), the parameters of the digital precision pressure load cell **Pendeo® Process** are configured.

Accessible via **MENU** - [Operating] - [System setup] - [Weighing points] - [Weighing point x] - [Parameters] .

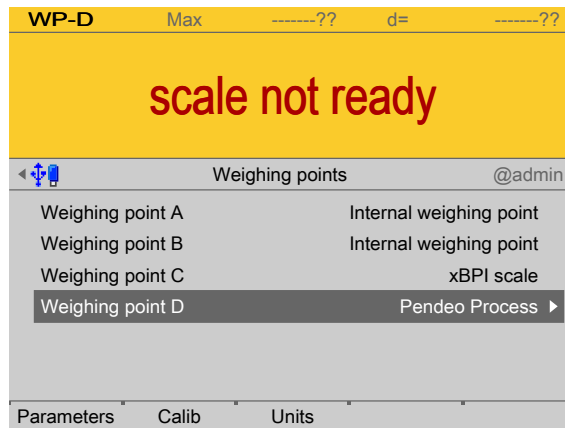

1. In this case: Select [Weighing point D] with [Pendeo Process] and press the [Parameters] soft key.

▷ A selection window opens.

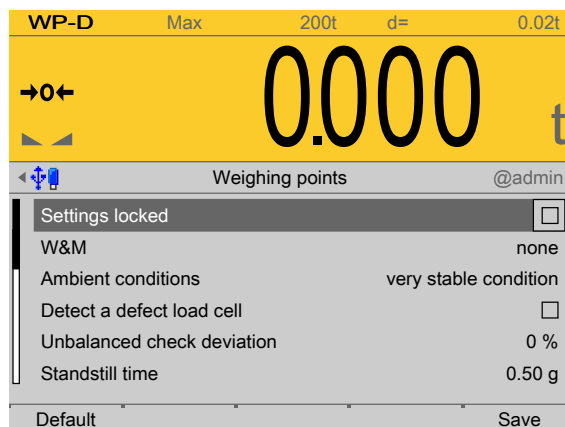

2. Select and confirm the individual parameters.

[Settings locked]

The weighing point settings and assignment can only be viewed as if the corresponding CAL switch were closed; see Chapter [2.7.1](#).

[W&M]

Setting for operation in legal metrology.

Selection: [None], OIML, NTEP (for USA) or NSC (for Australia), see Chapter [4.7.1.1.1](#).

[Ambient conditions]

This parameter is used to define the ambient conditions of the scale.

Selection: very stable condition, Stable condition, Unstable condition, Very unstable condition

[Detect a defective load cell]

Select and confirm these parameters if the maximum simulation of a faulty load cell is to be performed automatically. A warning symbol is displayed as long as the load cell is being simulated.

[Unbalanced check deviation]

The plausibility check is activated when the average deviation is > 0%.

The average deviation of the individual load cells is calculated. Monitoring is indicated via symbol above the weight unit.

Setting range: 0 to 100%.

[Standstill time]

The parameters [Standstill time] and [Standstill range] are used to define the standstill of the scale (stable balance).

The [Standstill time] parameter is entered in seconds. The permitted range is: 0.00...2 s.

The time can be entered from 0.00 to 2.00 seconds, but always makes up at least one measurement time.

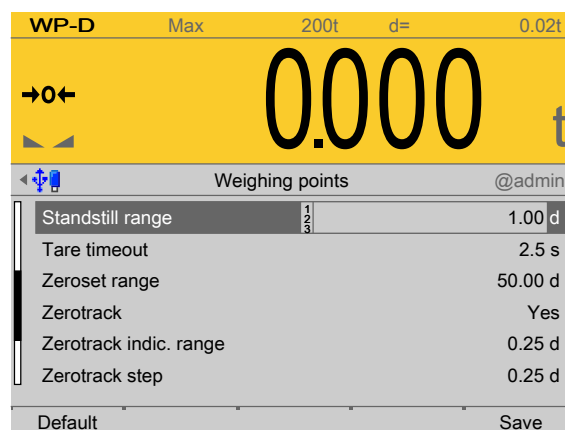
**[Standstill range]**

As long as the weight fluctuations remain within this range, the device is determined to be stable.

The [Standstill range] parameter is entered in "d". The permitted range is: 0.01...10.00 d.

For use in legal metrology, ≤1 d must be selected.

[Tare timeout]

Timeout for a tare/zeroset command that cannot be executed (e.g. due to mechanical instability of the scale, incorrect filter setting, resolution too high, standstill condition too strict).

This parameter is given in seconds. The permitted range is: 0.0...[2.5]...25 s.

At 0.0 s taring is only carried out when the scale is already stable.

[Zeroset range]

Determine a \pm range around the zero point determined by the dead load during calibration; within this range

- the displayed gross weight can be set to zero by pressing the zero-setting key (or by a corresponding external command), and
- automatic zero tracking is active.

Setting range: 0.00...10000.00 d

For use in legal metrology a value $\leq 2\%$ of the max must be entered, example: 60 d for 3000 e of Class III.

[Zerotrack]

The zero display is automatically maintained within set limits.

Selection: No/Yes

When [No] is selected, the next three parameters are not shown.

When [Yes] is selected, values for the next three parameters must be entered.

[Zerotrack indic. range]

Indication range within which automatic zero-track compensates for deviations.

Setting range: 0.25...10000.00 d

For use in legal metrology a value of < 0.5 d must be entered.

[Zerotrack step]

If a weight change exceeds the adjusted value, automatic tracking does not function any more.

Setting range for automatic tracking increments: 0.25...10 d

For use in legal metrology a value of ≤ 0.5 d must be entered.

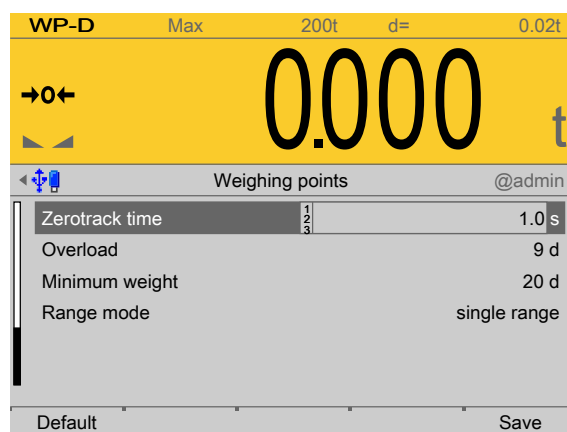

[Zerotrack time]

Time interval for automatic zerotrack.

Setting range: 0.1...25 s

For use in legal metrology a value of 1 s must be entered.

[Overload]

Weighing range above the maximum capacity (Max) without error message.

Setting range: 0...9999999 d

For use in legal metrology a value of max. 9 d = e must be set.

[Min. weight]

Minimum weight at which a print command can be triggered.

Setting range: 0...9999999 d

For use in legal metrology a value of at least 20 d must be set.

[Range mode]

Selection: single range, multi-range, multi-interval

For range selection for scales and settings, refer to Chapter [4.7.1.1.2](#) and [4.7.1.1.3](#)

[Default] soft key

Settings are reset to factory settings.

3. Press the [Save] soft key to save the settings.

4.7.8.3 Calib

In this menu item, calibration is performed for the digital precision pressure load cell **Pendeo® Process**.

- [Quick install with search load cells and set dead load], see Chapter [4.7.8.3.1](#).
- [Search for connected load cells], see Chapter [4.7.8.3.2](#).
- [View and assign load cells], see Chapter [4.7.8.3.3](#).
- [Calibrate the scale] (load cells), see Chapter [4.7.8.3.4](#).
 - [New], see Chapter [4.7.8.3.4.1](#).
 - [Modify], see Chapter [4.7.8.3.4.2](#).
- [Assign load cell name], see Chapter [4.7.8.3.5](#).
- [Service function for load cells], see Chapter [4.7.8.3.6](#).
- [Corner correction], see Chapter [4.7.8.3.7](#).

During calibration, no data is changed in the digital load cells. The calibration data and parameters are saved in the device. The unique serial numbers of the connected load cells are monitored.

For the calibration the following order must be followed:

- Search for load cells and set dead load, see Chapter [4.7.8.3.2](#) or
- Search for load cells only, see Chapter [4.7.8.3.3](#).
- Assign load cells, see Chapter [4.7.8.3.3](#).

- Recalibrate: Maximum capacity with weight unit, scale interval, dead load, calibration weight, see Chapter [4.7.8.3.4.1](#).
- Perform a corner correction if necessary; see Chapter [4.7.8.3.7](#)

Note:

For further information about calibrating weighing points, see Chapter [4.7.1](#).

Accessible via **MENU** - [Operating] - [System setup] - [Weighing points] - [Weighing point x] - [Calib] .

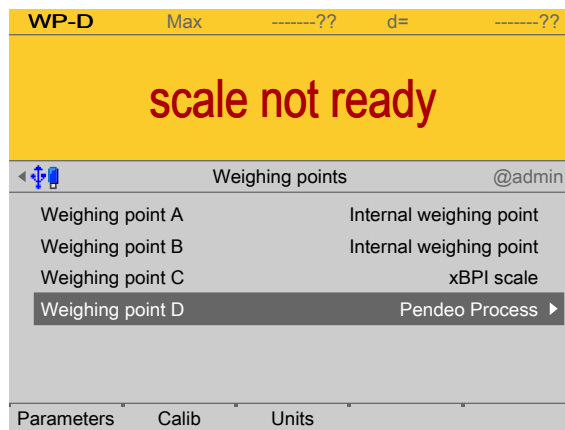

- ▶ In this case: Select [Weighing point A] with [Pendeo Process] and press the [Calib] soft key.
 - ▷ The Pendeo setup menu opens.

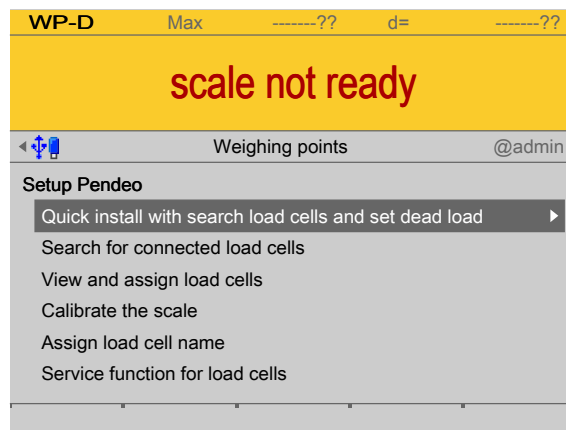

4.7.8.3.1 Quick install with search load cells and set dead load

In this menu item (under **Calib**), quick install with search and setting of the dead load is performed for the digital precision pressure load cell **Pendeo® Process**.

Accessible via **MENU** - [Operating] - [System setup] - [Weighing points] - [Weighing point x] - [Calib] - [Quick install with search load cells and set dead load] .

1. Unload the scale.

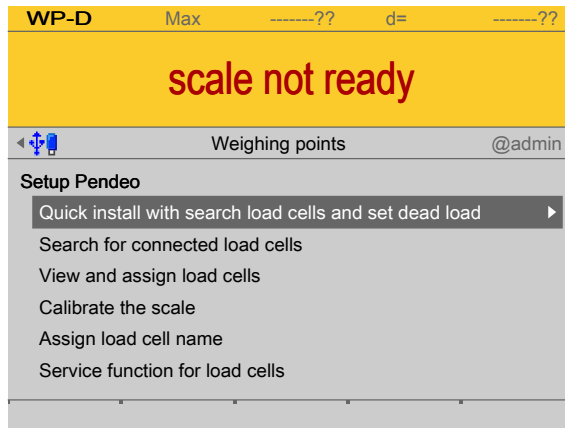

2. Select and confirm [Quick install with search load cells and set dead load].
 - ▷ A prompt window appears.

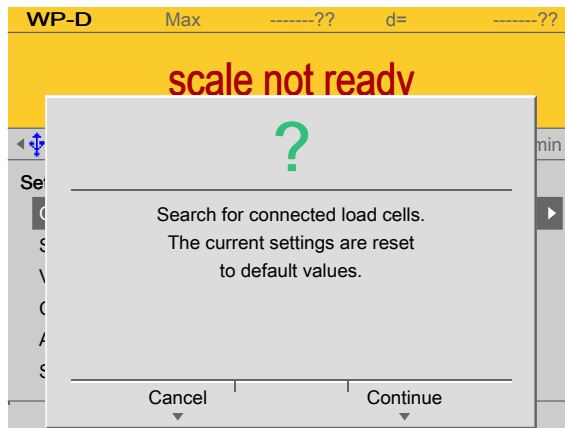

3. Press the [Continue] soft key to start the search.
 - Press the [Cancel] soft key to return to the Pendeo setup menu.
 - ▷ An input window opens.

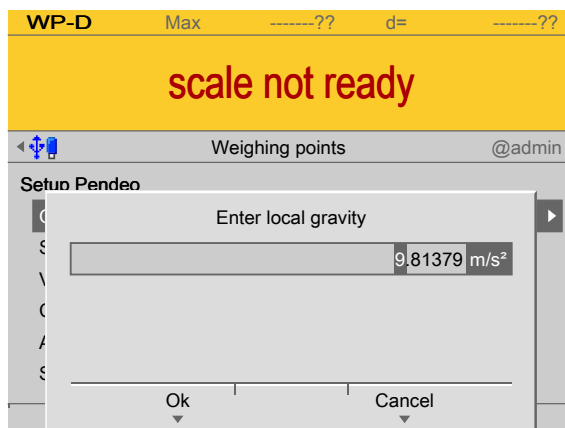

4. If necessary, change the present value and press the [OK] soft key to confirm the entry.
 - Press the [Cancel] soft key to return to the Pendeo setup menu.
 - ▷ The search is started and the dead load is set. The Pendeo setup menu appears after this is complete.

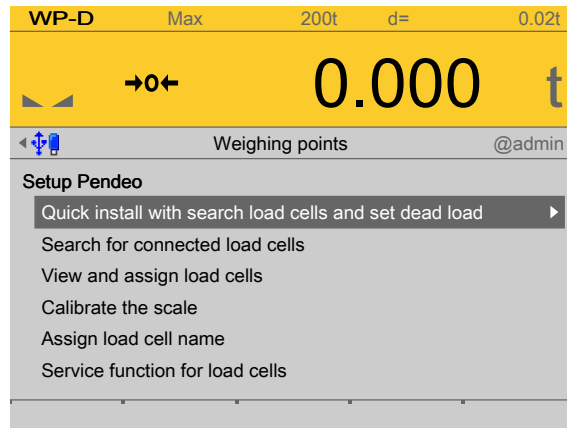

4.7.8.3.2 Search for connected load cells

In this menu item (under **Calib**), a search is performed for connected load cells of the digital precision pressure load cell **Pendeo® Process**.

Accessible via **MENU** – [Operating] - [System setup] - [Weighing points] - [Weighing point x] - [Calib] - [Search for connected load cells].

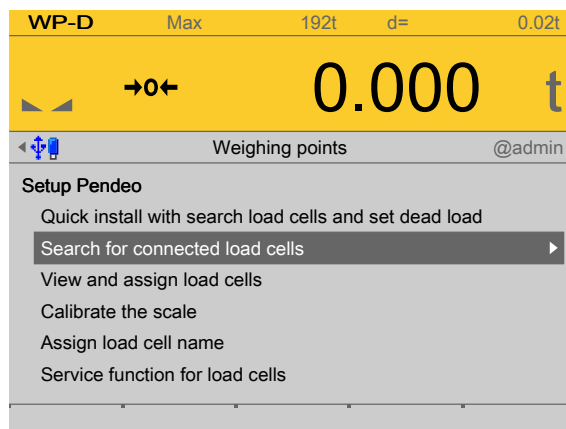

1. Select and confirm [Search for connected load cells].
▷ A prompt window opens.

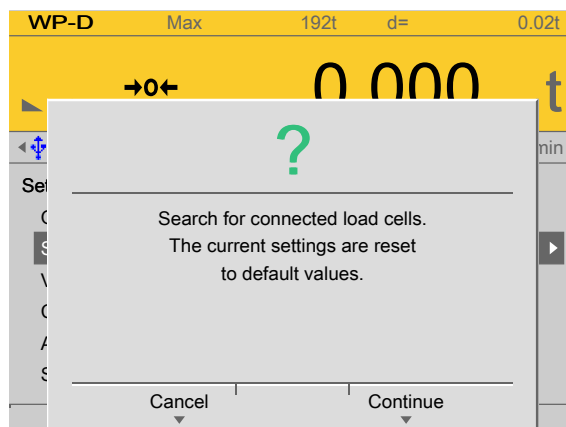

2. Press the [Continue] soft key to start the search.
Press the [Cancel] soft key to return to the Pendeo setup menu.
▷ The search is started.

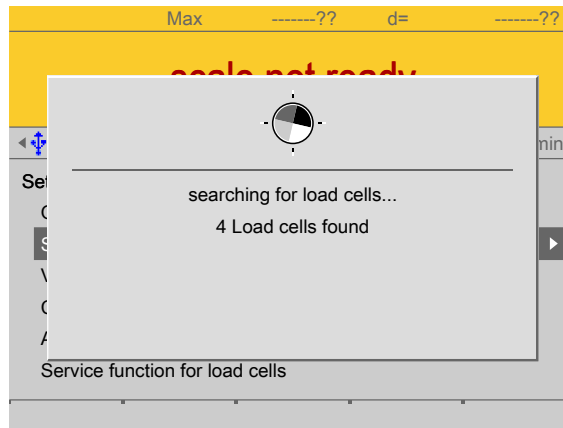

The Pendeo setup menu appears after this is complete.

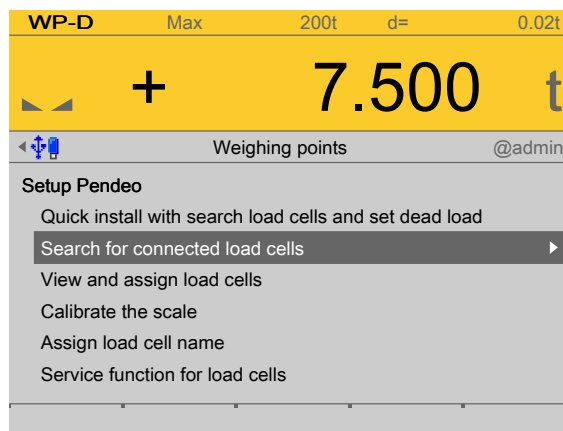

4.7.8.3.3 View and assign load cells

In this menu item (under **Calib**), the load cell data of the digital precision pressure load cell **Pendeo® Process** is displayed and assigned to the individual installation locations.

- [Info] (display load cell data), see Chapter [4.7.8.3.3.1](#).
- [Assign] (installation locations), see Chapter [4.7.8.3.3.2](#).

Accessible via **MENU** - [Operating] - [System setup] - [Weighing points] - [Weighing point x] - [Calib] - [View and assign load cells] .

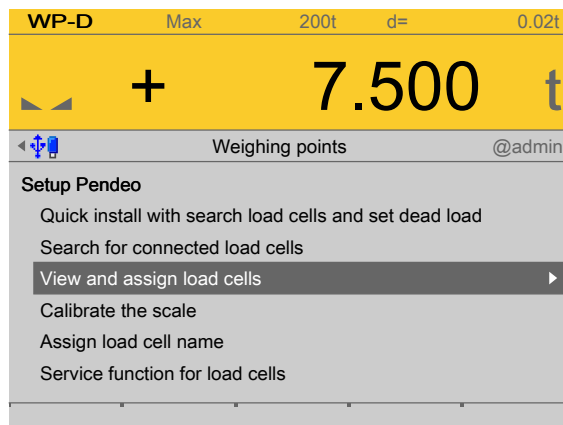

- ▶ Select and confirm [View and assign load cells].
 - ▷ The load cells are displayed with their item number, serial number, and load.

LC 1	101	1.471 t
LC 2	103	1.613 t
LC 3	104	2.087 t
LC 4	102	2.337 t

4.7.8.3.3.1 Info (display load cell data)

In this menu item (under **View and assign load cells**), the load cell data of the digital precision pressure load cell **Pendeo® Process** is displayed.

Accessible via **MENU** - [Operating] - [System setup] - [Weighing points] - [Weighing point x] - [Calib] - [View and assign load cells] - [Info] .

LC 1	101	1.471 t
LC 2	103	1.613 t
LC 3	104	2.087 t
LC 4	102	2.337 t

The load cells are displayed with their item number, serial number, and load.

1. Select the desired load cell and press the [Info] soft key.

Note:

If load cell names have been assigned (see Chapter [4.7.8.3.5](#)), the view can be switched with the [by name] soft key.

- ▷ The load cell data is displayed.

+ 7.500 t	
Load cell info @admin	
Model name	PR6224/50tC3
Software version	1.00.04
LC serial number	104
Emax	50.0 t
n	3000 e
Y	14000
Z	3000
Overload	75.0 t
Overload counter	0

2. Press **EXIT** to return to the previous window.

4.7.8.3.2 Assign (installation locations)

In this menu item (under **View and assign load cells**), the load cells (serial numbers) of the digital precision pressure load cell **Pendeo® Process** are assigned to the installation locations.

This is important for correcting the dead load (distribution to the individual load cells), for corner correction and in the event of load cell replacement.

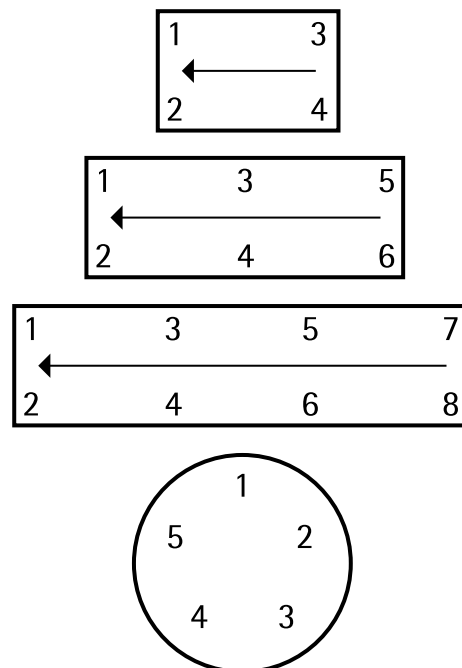

Example of a possible allocation.

Note:

The assignment from the installation should be documented in the case of load cells being replaced.

Accessible via **MENU** - [Operating] - [System setup] - [Weighing points] - [Weighing point x] - [Calib] - [View and assign load cells] - [Assign] .

1. Unload the scale.

+ 7.500 t		
View @admin		
LC 1	101	1.471 t
LC 2	103	1.613 t
LC 3	104	2.087 t
LC 4	102	2.337 t

Info Assign by name Accept

2. Press the [Assign] soft key.

▷ A prompt is shown.

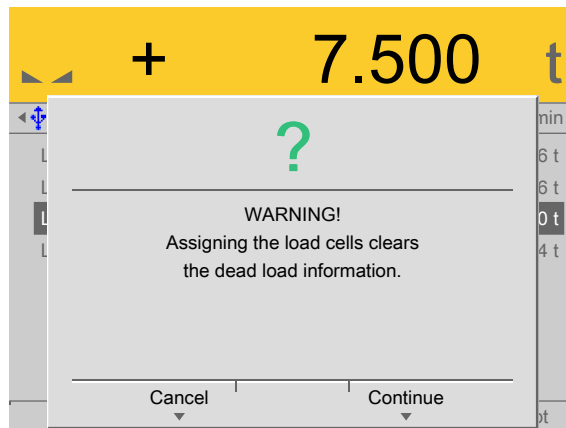

3. Press the [Continue] soft key.

The load cells are assigned by placing minimum weights on the scale.

+ 13.140 t		
Weighing points @admin		
LC 1	101	4.159 t 1
LC 2	103	1.744 t 0
LC 3	104	3.689 t 0
LC 4	102	3.542 t 0

Info Assign by name Accept

4. Place the weight on the corner/load cell that will later be assigned no. 1.
 - ▷ As soon as the device detects the weight change, the corresponding line is selected.
5. Press the [Accept] soft key.
 - ▷ The future LC no. is shown at the far right of the line.
6. Remove the calibration weight.
7. Repeat these steps for load cells 2 to 4.

8. Press the [Save] soft key to save the new assignment.
 - ▷ The Pendeo setup menu opens.

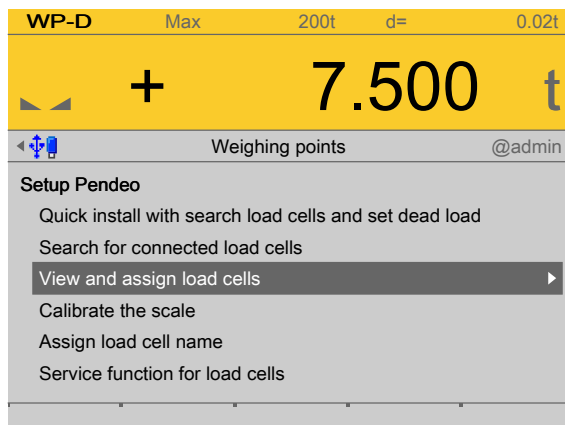

9. Select and confirm [View and assign load cells].
 - ▷ The new assignment will be displayed.

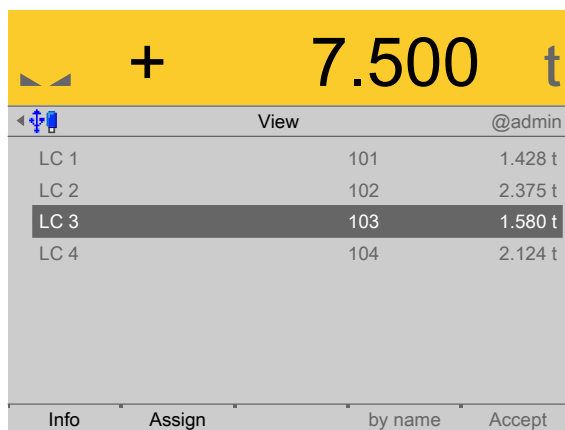

10. Check the corner load (dead load) if necessary; see Chapter [4.7.8.3.7](#).
11. Press **EXIT** to return to the previous window.

4.7.8.3.4 Calibrate the scale

In this menu item (under **Calib**), the load cells of the digital precision pressure load cell **Pendeo® Process** are calibrated.

- [New], see Chapter [4.7.8.3.4.1](#).
- [Modify], see Chapter [4.7.8.3.4.2](#).
- Dead load (correction), see Chapter [4.7.7.3.4.3](#).

Note:

The menu item [Modify] is only used for minor changes (e.g. changing the dead load/preload). Otherwise, the menu item **[New]** should be selected.

Accessible via **MENU** – [Operating] - [System setup] - [Weighing points] - [Weighing point x] - [Calib] - [Calibrate the scale] .

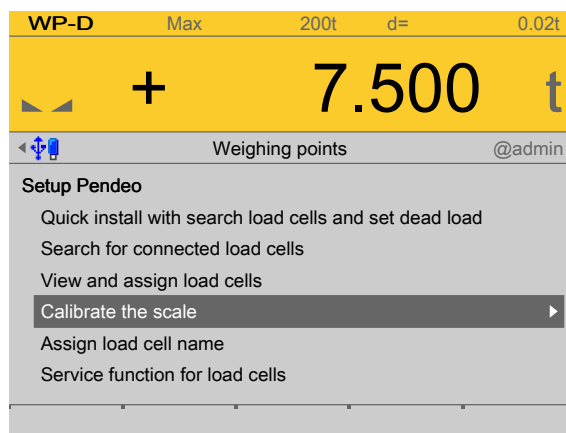

- ▶ Select and confirm [Calibrate the scale].
 - ▷ The data from the last calibration is displayed.

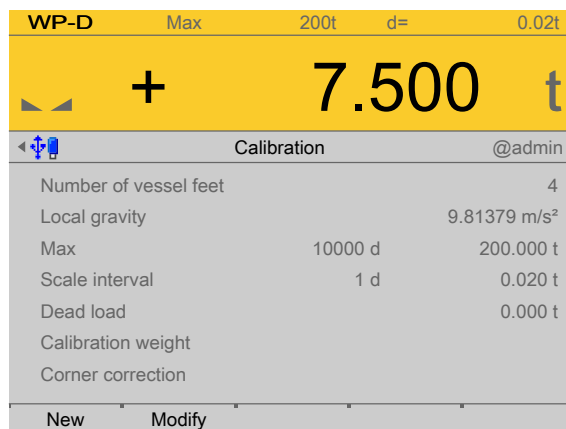

- The [New] soft key starts a new calibration, see Chapter [4.7.8.3.4.1](#).
- The [Modify] soft key (only use for small changes!) changes an existing calibration, see Chapter [4.7.8.3.4.2](#).

4.7.8.3.4.1 New

In this menu item (under **Calibrate the scale**), a new calibration of the digital precision pressure load cell **Pendeo® Process** is performed and configured.

Example data:

- Maximum capacity of a load cell: $E_{max} = 50 \text{ t}$
- Number of load cells: 4
- Number of vessel feet: 4
- Max: 200.000 t
- Scale interval: 0.020 t
- Dead load: Empty weight
- Calibration weight: 11.000 t

Accessible via **MENU** - [Operating] - [System setup] - [Weighing points] - [Weighing point x] - [Calib] - [Calibrate the scale] - [New] .

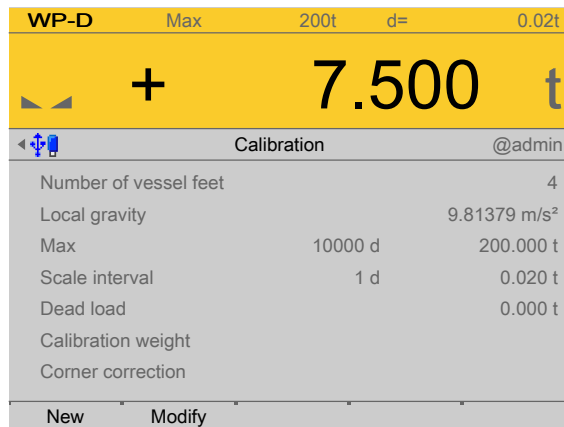

The data from the last calibration is displayed.

1. Press the [New] soft key.

Note:

The menu item [Modify] is only used for minor changes (e.g. changing the dead load/preload). Otherwise, the menu item [**New**] should be selected.

- ▷ A prompt window appears.

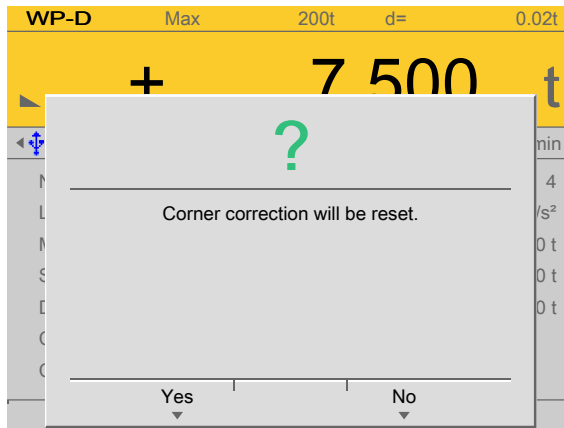

2. Press the [Yes] soft key.

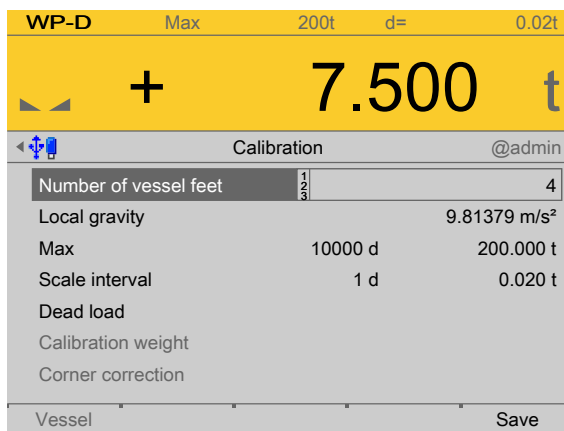

3. Select [Number of vessel feet], change if necessary, and confirm.

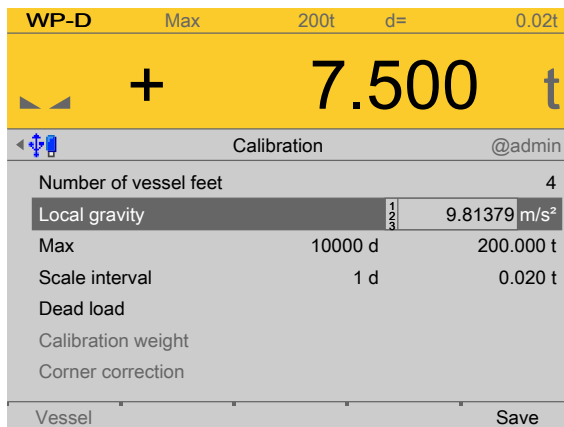

4. Select [Local gravity], change if necessary, and confirm.

WP-D		Max	200t	d=	0.02t
		+ 7.500		t	
←		Calibration		@admin	
Number of vessel feet				4	
Local gravity				9.81379 m/s ²	
Max		10000 d	$\frac{1}{2}$	$\frac{2}{3}$	200.000 t
Scale interval		1 d			0.020 t
Dead load					
Calibration weight					
Corner correction					
Vessel		Save			

5. Enter [Max] (maximum capacity) with decimal places (in this example: 200.000 t).
6. Press the  key (2x) to select the weight unit.
7. Confirm the entries.

▷ The confirmation is displayed with "setting Max...".

The weight unit is taken from [Max]. The number of digits behind the decimal point is also automatically determined when [Max] is entered.

WP-D		Max	200t	d=	0.02t
		+ 7.500		t	
←		Calibration		@admin	
Number of vessel feet				4	
Local gravity				9.81379 m/s ²	
Max		10000 d			200.000 t
Scale interval		1 d			0.020 t
Dead load					
Calibration weight					
Corner correction					
Vessel		Save			

8. Select the [scale interval] (1 d).
 - ▷ The scale interval (d) is calculated, based on the maximum weight value.
9. Confirm the entries.
 - ▷ The confirmation is displayed with "setting scale interval..."

To use the empty scale as dead load (normal case):
10. Do not load scale.

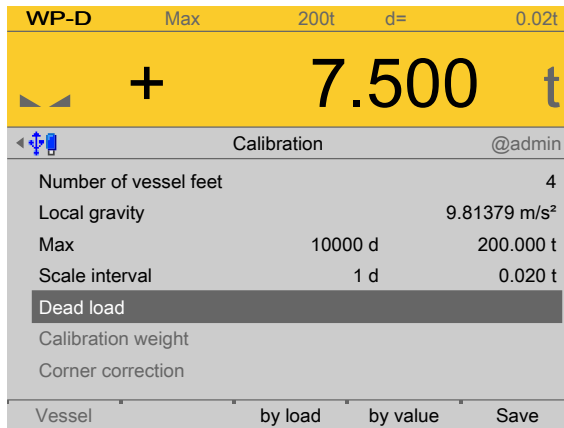

11. Press the [By load] soft key.

Note:

Once the dead load is known, the value can be overwritten by pressing the [by value] soft key.

12. Confirm the entries.

▷ The confirmation is displayed with "Setting dead load..."

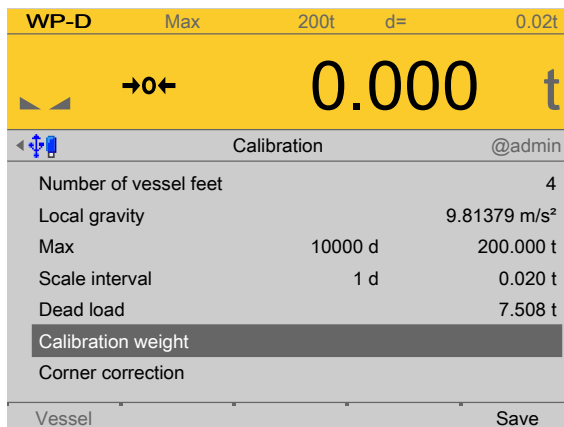

13. Select and confirm [Calibration weight].

▷ An input window opens.

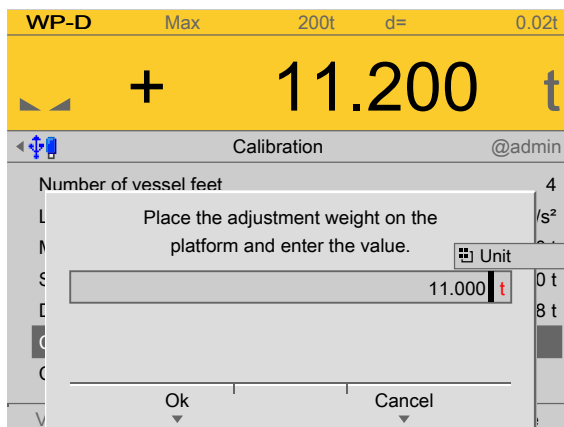

14. Place calibration weight on the center of the scale and enter the weight value.

15. Press the [OK] soft key and remove the calibration weight.
 - ▷ The corner load (dead load set to zero) is displayed.

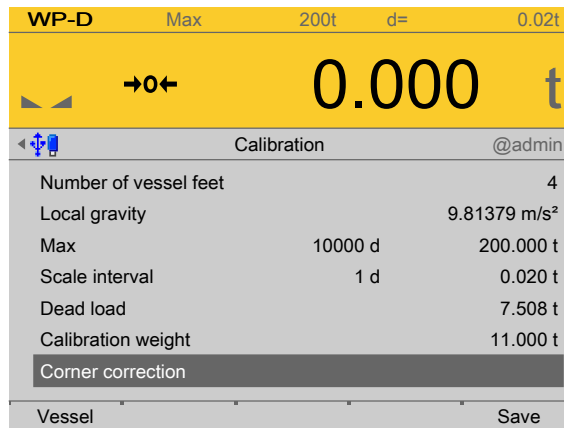

16. Perform a corner correction if necessary; see Chapter [4.7.8.3.7](#).
17. Press the [Save] soft key to save the calibration.

4.7.8.3.4.2 Modify

In this menu item (under **Calibrate the scale**), changes are made to an existing calibration of the digital precision pressure load cell **Pendeo® Process**.

- For parameters (local gravity, maximum capacity, scale interval, calibration weight), see Chapter [4.7.8.3.4.1](#).
- Dead load (subsequent correction), see Chapter [4.7.8.3.4.3](#).
- Corner correction, see Chapter [4.7.8.3.7](#)

Accessible via **MENU** - [Operating] - [System setup] - [Weighing points] - [Weighing point x] - [Calib] - [Calibrate the scale] - [Modify] .

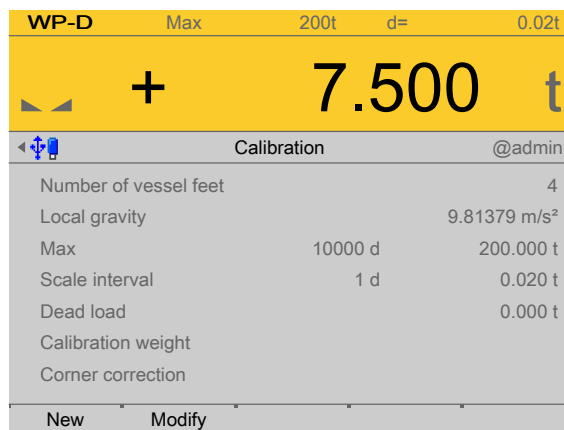

The data from the last calibration is displayed.

1. Press the [Modify] soft key.

Note:

The menu item [Modify] is only used for minor changes (e.g. changing the dead load/preload). Otherwise, the menu item **[New]** should be selected.

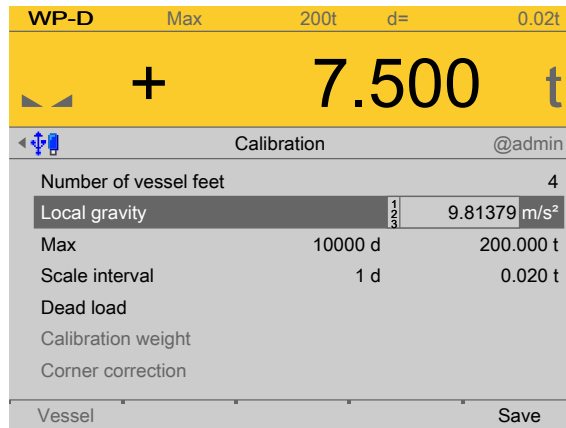

2. Select the individual parameters and confirm.

For description and settings of the parameters, refer to Chapter [4.7.8.3.4.1](#).

3. Press the [Save] soft key to save the calibration.

4.7.8.3.4.3 Dead load (correction)

In this menu item, the dead load is modified for the digital precision pressure load cell **Pendeo® Process**.

If the platform weight changes by an amount that is higher than the zero range, e.g., due to dead load reduction, dead load increase, or mechanical changes, the functions for automatic zero tracking and manual zero setting no longer work.

If the entire zeroset range is already utilized, you can still correct the dead load without affecting other calibration data/parameters.

Accessible via **MENU** - [Operating] - [System setup] - [Weighing points] - [Weighing point x] - [Calib] - [Calibrate the scale] - [Modify] - [Dead load] .

1. The scale must be empty (empty vessel).

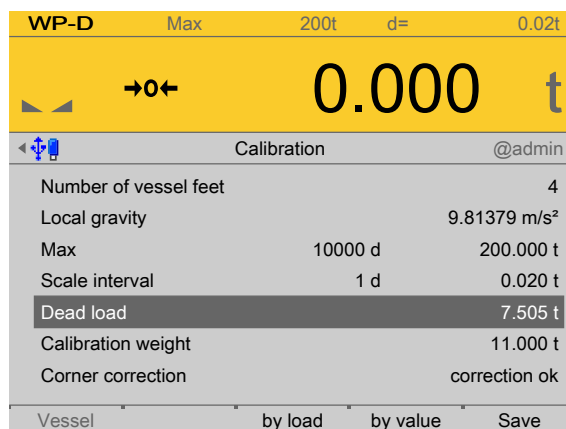

2. Select and confirm [Dead load].
3. Check the corner load; see Chapter [4.7.8.3.7](#).
4. Perform a corner correction if necessary; see Chapter [4.7.8.3.7](#).
5. Press the [Save] soft key to save the current dead load.

4.7.8.3.5 Assign load cell name

In this menu item (under **Calib**), each load cell of the digital precision pressure load cell **Pendeo® Process** can be given a name.

Accessible via **MENU** - [Operating] - [System setup] - [Weighing points] - [Weighing point x] - [Calib] - [Assign load cell name] .

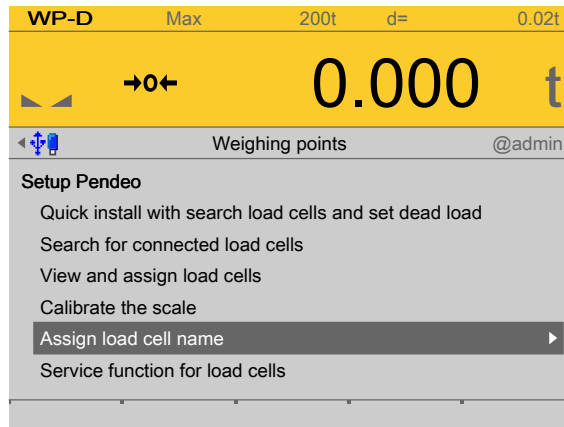

1. Select and confirm [Assign load cell name].
 ▷ An input window opens.

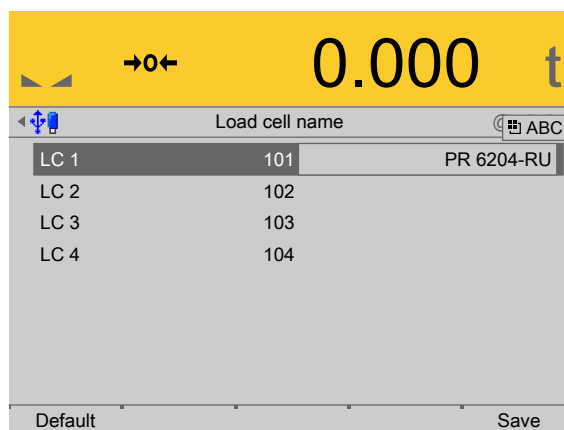

2. Select the load cells in succession, enter the name using the keyboard and confirm.
3. Press the [Save] soft key to save the entry.

4.7.8.3.6 Service function for load cells

In this menu item (under **Calib**), faulty load cells of the digital precision pressure load cell **Pendeo® Process** can be deactivated and replacement load cells activated.

Accessible via **MENU** – [Operating] - [System setup] - [Weighing points] - [Weighing point x] - [Calib] - [Service function for load cells] .

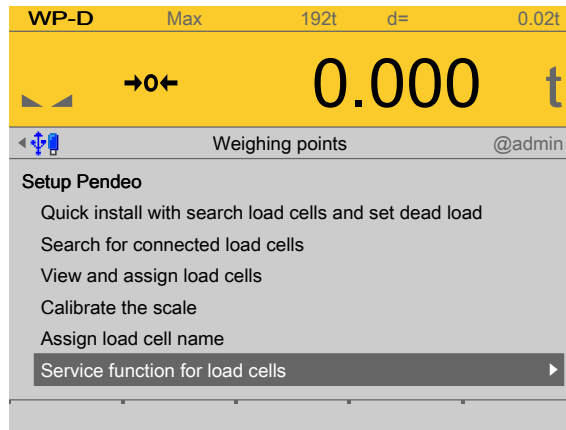

1. Select and confirm [Service function for load cells].
 ▷ The service window opens.

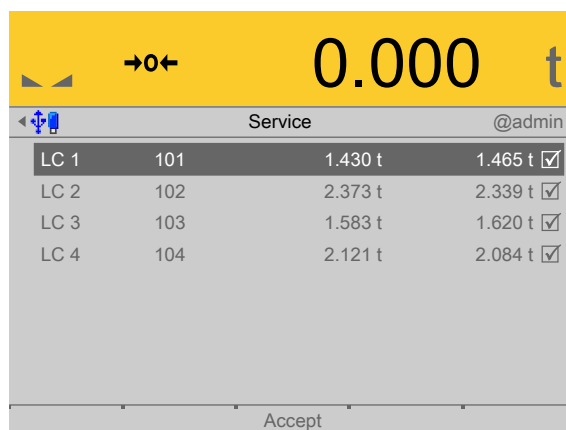

Item number, serial number, dead load, and current load of connected load cells are displayed.

Deactivating the load cell

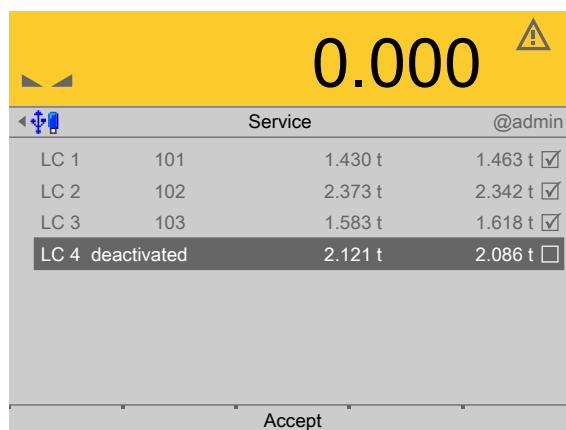

2. Select the faulty load cell and confirm to deactivate the cell.

- ▷ The warning symbol replaces the weight unit.
- 3. Press the [Accept] soft key.
 - ▷ The simulation of the deactivated load cell is started.

Activating the load cell

After inserting and connecting the new load cell:

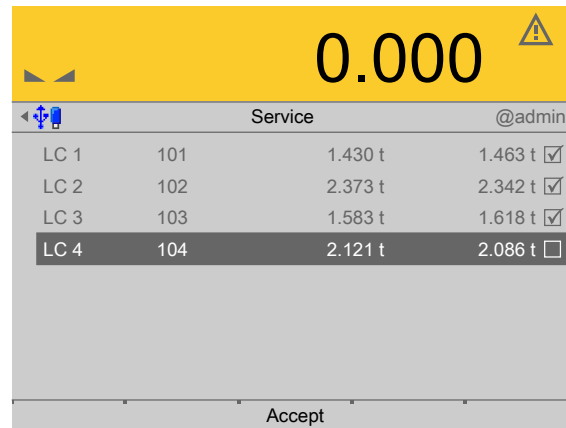

- 4. Select and confirm the deactivated load cell.
 - 5. Press the [Accept] soft key.
 - ▷ A search is started.
- Only then will the new load cell be recognized.

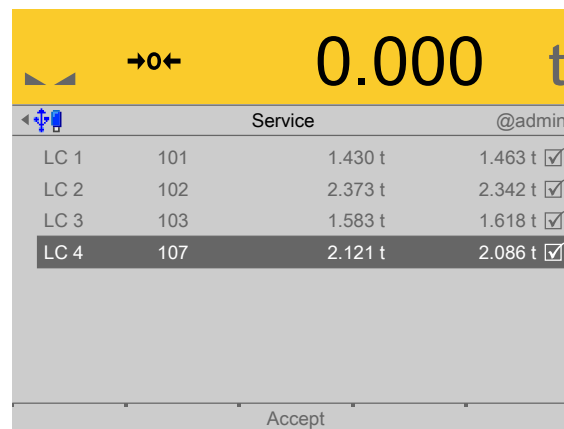

4.7.8.3.7 Corner correction

In this menu item (under **Calib**), corner correction is performed for the digital precision pressure load cell **Pendeo® Process**.

For asymmetric scale structures a corner correction is not necessary.

However, corner correction may be required for symmetric scale structures.

Checking the corner load (dead load):

After assignment (see Chapter [4.7.8.3.3](#)) and calibration (see Chapter [4.7.8.3.4](#)), the position of the load cells is clearly defined.

Software corner correction:

If the corners are loaded in succession, the same value should be displayed on the device at all times. An excessive deviation almost always means that the scale is tilted or indicates load cell force shunts.

If the signal deviations cannot be resolved by carefully leveling the scale, the software must be calibrated.

Accessible via **MENU** - [Operating] - [System setup] - [Weighing points] - [Weighing point x] - [Calib] - [Modify] - [Corner correction] .

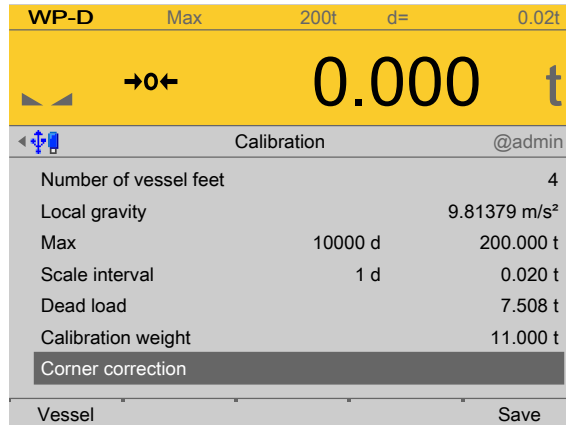

1. Select [Corner correction].
2. Press the [Vessel] soft key.
3. Place the calibration weight on a corner.

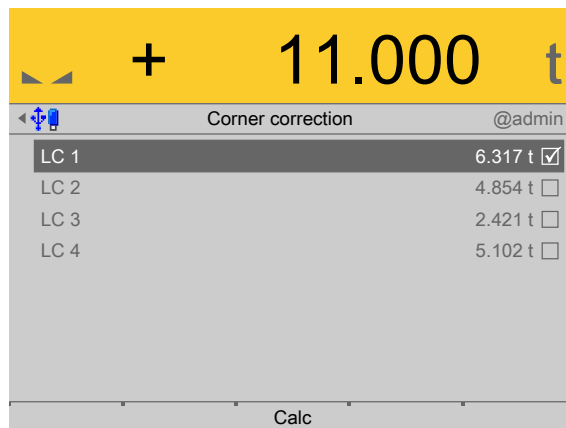

4. Position (here: LC 1) is highlighted.
5. Confirm position.
6. Remove the calibration weight.
7. Repeat steps 1 to 6 for the remaining load cells.

You are free to choose any desired order.

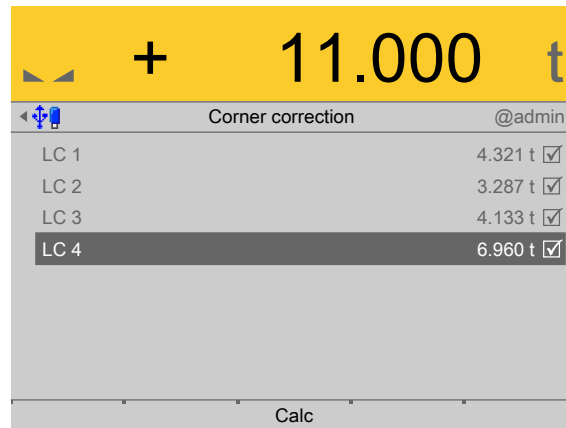

8. Once all load cells have been loaded one time, press the [Calculate] soft key to perform corner correction.
 - ▷ The total weight remains unchanged. Only the effect of the individual load cells is corrected.

When corner correction is completed, it is marked with [Correction ok].

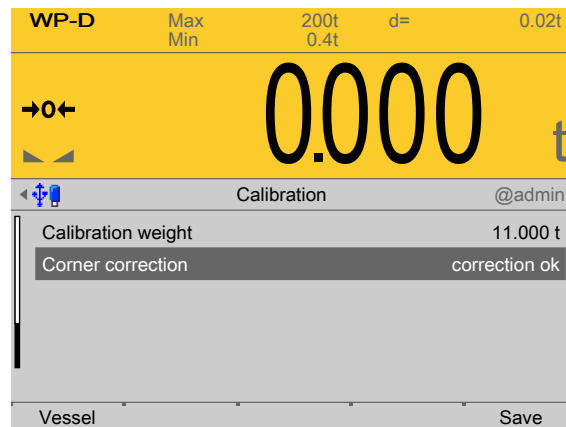

9. Press the [Save] soft key to save the corner correction.

4.7.8.4 Units

In this menu item, the display units and display accuracy of the weighbridge load cell **Pendeo® Process** are configured.

Descriptions and settings can be found in the [Internal weighing point] menu; see Chapter [4.7.1.3](#).

Accessible via **MENU** - [Operating] - [System setup] - [Weighing points] - [Weighing point x] - [Units] .

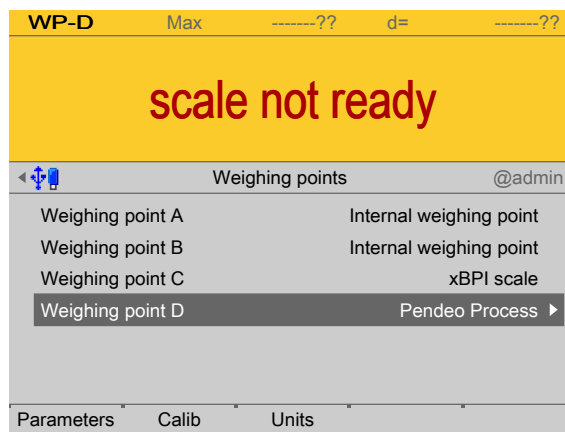

- ▶ In this case: Select [Weighing point D] with [Pendeo Process] and press the [Units] soft key.

Descriptions and settings can be found in the [Internal weighing point] menu; see Chapter [4.7.1.3](#).

4.7.9 PR-Net weighing point

In this menu item (under **Weighing points**), the weighing electronics of a **PR-Net weighing point** are assigned to a logical weighing point and configured.

- [Parameters] (weighing electronics), see Chapter [4.7.9.1](#).

PR 5900 can communicate with the following indicators via the network protocol:

- PR 5220
- PR 5230
- PR 5410

The determination and transmission of weight depends on the devices. Weight values up to seven digits plus preceding +/- sign can be displayed. Before the weighing electronics can be assigned to the logical weighing point, the scale (e.g.: PR 5230 + load cells) must be calibrated and configured accordingly. The calibration cannot be modified via the network protocol.

Accessible via **MENU** - [Operating] - [System setup] - [Weighing points] - [Weighing point x] - [Weighing point] - [PR-Net weighing point] .

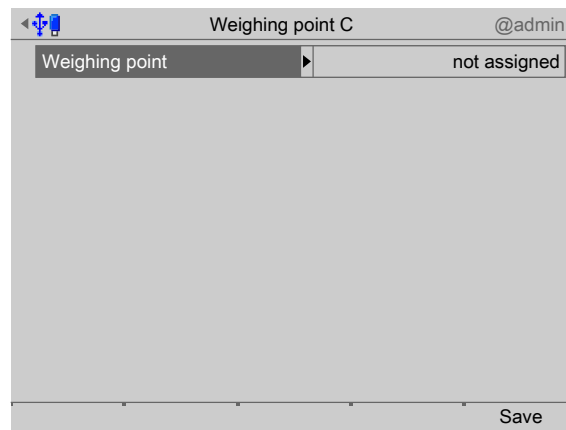

1. Confirm [Weighing point].

▷ A selection window opens.

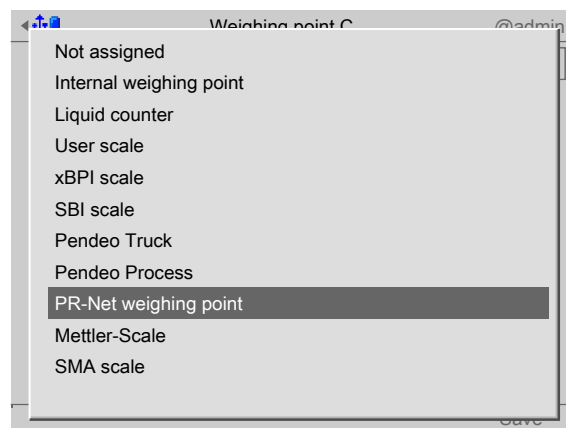

2. Select and confirm [PR-Net weighing point].
3. Press the [Save] soft key to save the settings.
 - ▷ The weighing electronics are now assigned to the weighing point.

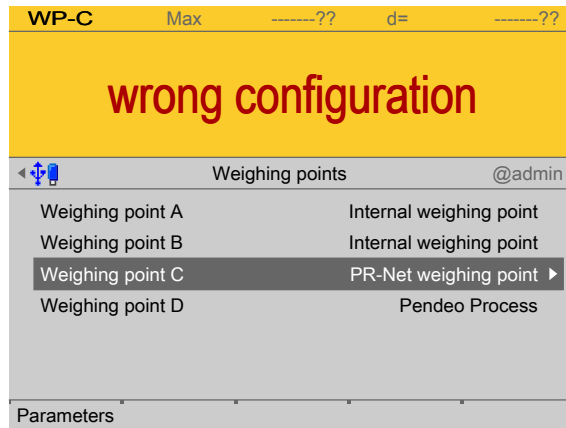

4.7.9.1 Parameters

In this menu item, the parameters of the **PR-Net weighing point** weighing electronics are configured.

Accessible via **MENU** - [Operating] - [System setup] - [Weighing points] - [Weighing point x] - [Parameters] .

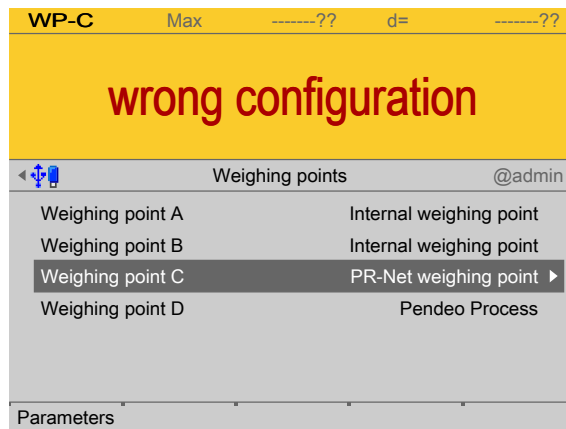

1. In this case: Select [Weighing point C] with [PR-Net weighing point] and press the [Parameters] soft key.

▷ A selection window opens.

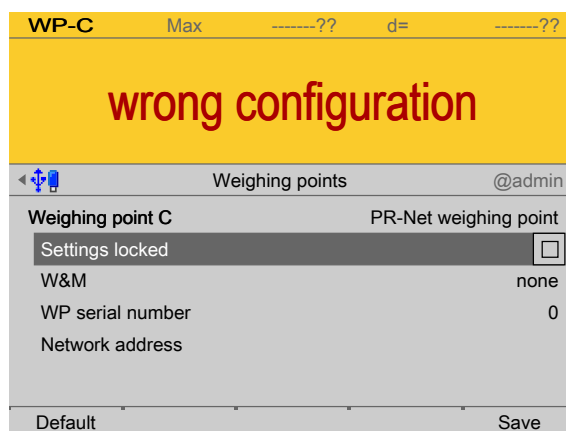

2. Select and confirm the individual parameters.

[Settings locked]

The weighing point settings and assignment can only be viewed as if the corresponding CAL switch were closed; see Chapter [2.7.1](#).

[W&M]

Setting for operation in legal metrology.

Selection: [None], OIML, NTEP (for USA) or NSC (for Australia), see Chapter [4.7.1.1.1](#).

[WP Serial number]

Serial number of the connected indicator. With serial number 0, checking is omitted.

Input range: 0 to 99999999

[Network address]

Input:

- IP address of the connected indicator or
- Host name of the connected indicator

Note:

A host name can only be entered if

- A name server exists in the network that knows the device host name.
- [Operating]- [System setup]- [Network parameters]- [Use DHCP] is activated for the PR 5900 (otherwise the PR 5900 does not learn the address of the name server).

[Default] soft key

Settings are reset to factory settings.

3. Press the [Save] soft key to save the settings.
 - ▷ After saving, the weight value of the scale is displayed.

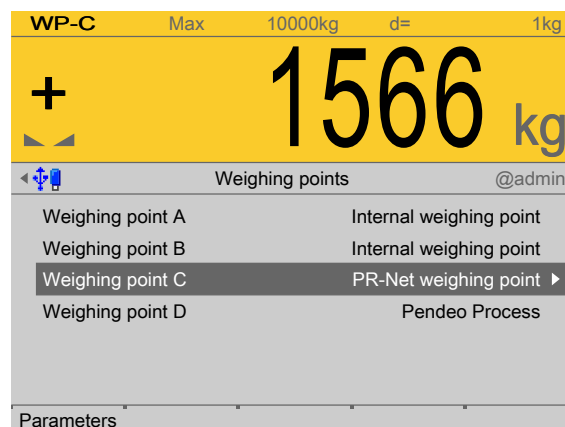
**4.7.10 Mettler-Scale**

In this menu item (**Weighing points**), the **Mettler-Scale** weighing electronics are assigned to a logical weighing point and configured.

- Example of parameter settings in the **Application menu**.

- [Interface] (serial), see Chapter [4.7.10.1](#).
- [Parameters] (weighing electronics), see Chapter [4.7.10.2](#).

PR 5900 can communicate with the Mettler-Scale via the MT-SICS protocol. A maximum of four scales can be connected via serial interfaces. Communication is serial.

The determination and transmission of weight depends strongly on the scale. Weight values up to seven digits plus preceding +/- sign can be displayed. The maximum capacity (Max) is already set in the Mettler-Scale and cannot be modified via the MT-SICS protocol.

Accessible via **MENU** - [Operating] - [System setup] - [Weighing points] - [Weighing point x] - [Weighing point] - [Mettler-Scale] .

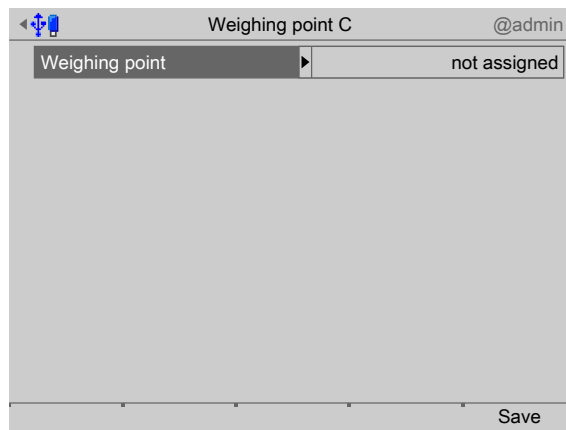

1. Confirm [Weighing point].
 - ▷ A selection window opens.

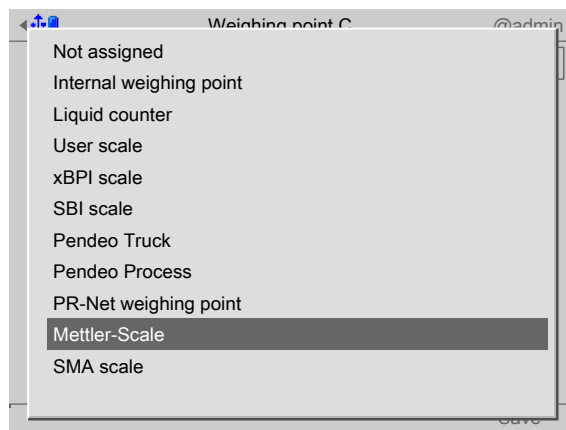

2. Select and confirm [Mettler-Scale].
3. Press the [Save] soft key to save the settings.
 - ▷ The weighing electronics are now assigned to the weighing point.

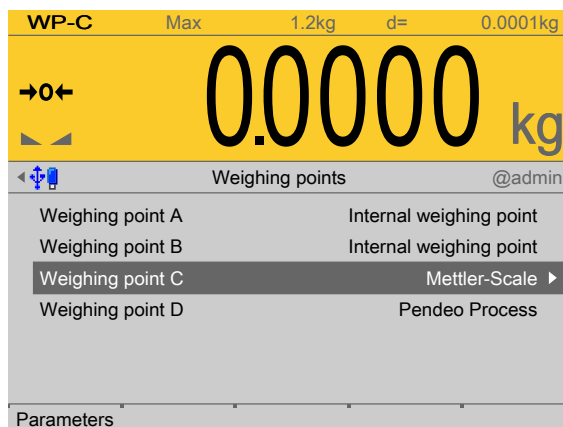

Example of parameter settings in the application menu

Example: Scale type XS6002SDR

Select [Peripheral devices] in the **application menu** and apply the following settings:

Peripheral device

— Printer	Off
— Host	
— RS232 fixed	
— Define	
— Baud rate	9.600
— Bit/Parity	7/Odd
— Stop Bits	1 Stop Bit
— Handshake	Xon/Xoff
— End of line	<CR> <LF>
— Char Set	IBM/DOS
— Continuous mode	Off
— Second display	Off
— Bar code	Off
— External keyboard	Off

4.7.10.1 Interface (serial)

In this menu item, the parameters of the serial interface for the **Mettler-Scale** weighing electronics are configured.

Accessible via **MENU** - [Operating] - [System setup] - [Weighing points] - [Weighing point x] - [Interface] .

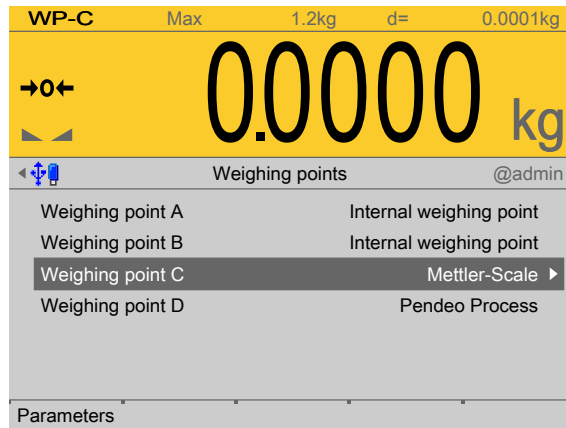

1. In this case: Select and confirm [Weighing point C] with [Mettler-Scale].
▷ A selection window opens.

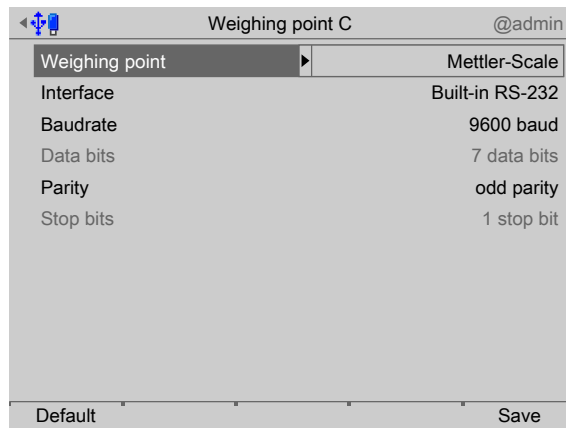

Inactive parameters are grayed out.

2. Select and confirm the individual parameters.

[Interface]

Serial interfaces.

Selection: not assigned, Built-in RS-232, Built-in RS-485, Option-x RS-485-A, Option-x RS-485-B

[Baud rate]

Baud rate of the data transfer.

Note:

The selected value must match the value of the connected device.

Selection: 300, 600, 1200, 2400, 4800, [9600], 19200 baud

[Parity]

Parity check for detecting errors during data transmission.

Selection: no parity, odd parity, even parity

[Default] soft key

Settings are reset to factory settings.

3. Press the [Save] soft key to save the settings.

4.7.10.2 Parameters

In this menu item, the parameters of the **Mettler-Scale** weighing electronics are configured.

Accessible via **MENU** - [Operating] - [System setup] - [Weighing points] - [Weighing point x] - [Parameters] .

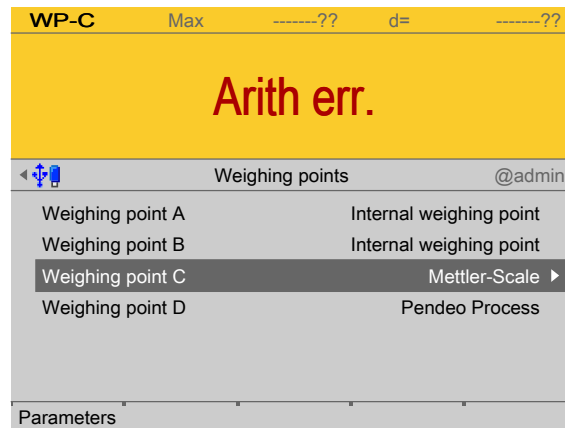

1. In this case: Select [Weighing point C] with [Mettler-Scale] and press the [Parameters] soft key.

▷ A selection window opens.

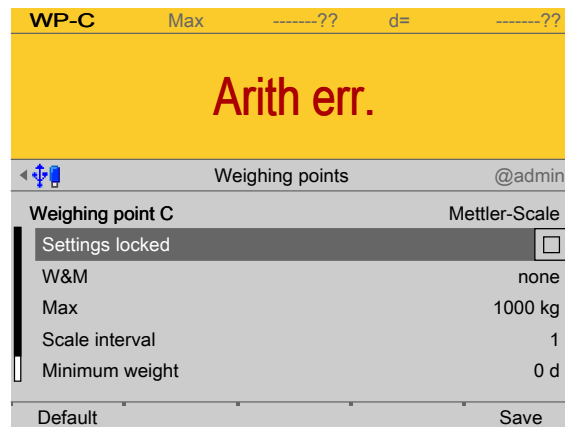

2. Select and confirm the individual parameters.

[Settings locked]

The weighing point settings and assignment can only be viewed as if the corresponding CAL switch were closed; see Chapter [2.7.1](#).

[W&M]

Setting for operation in legal metrology.

Selection: [None], OIML, NTEP (for USA) or NSC (for Australia), see Chapter [4.7.1.1.1](#).

[Max]

Enter the maximum capacity of the Mettler-Scale with decimal places and the weight unit.

Setting range: 0.000001...9999999 in mg, kg, t

[Scale interval]

The scale interval (d) is the difference between two successive display values.

See Chapter [4.7.1.2.1.2](#).

[Min. weight]

Minimum weight at which a print command can be triggered.

Setting range: 0...9999999 d.

For use in legal metrology a value of at least 20 d must be set.

[Update time]

Timeframe in which a new weight value is displayed.

Setting range: 0.1...2.0 s.

[Default] soft key

Settings are reset to factory settings.

3. Press the [Save] soft key to save the settings.
 - ▷ The weight value of the Mettler-Scale is displayed.

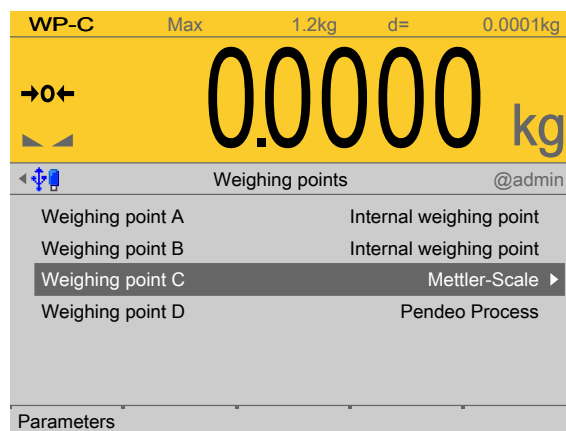

4.7.11 SMA scale

In this menu item (under **Weighing points**), the **SMA scale** weighing electronics are assigned to a logical weighing point and configured.

- [Interface] (serial), see Chapter [4.7.11.1](#).
- [Parameters] (weighing electronics), see Chapter [4.7.11.2](#).

PR 5900 can communicate with scales via the SMA protocol. The devices can be connected via serial interfaces (internal or PR 5900/04) (see the PR 5900 installation manual under [Device installation] - [Hardware construction] - [RS-485 interface (internal)] and under [Device installation] - [Accessories] - [PR 5900/04 2x RS-485 interface]). Communication is serial.

Accessible via **MENU** – [Operating] – [System setup] – [Weighing points] – [Weighing point x] – [Weighing point] – [SMA scale].

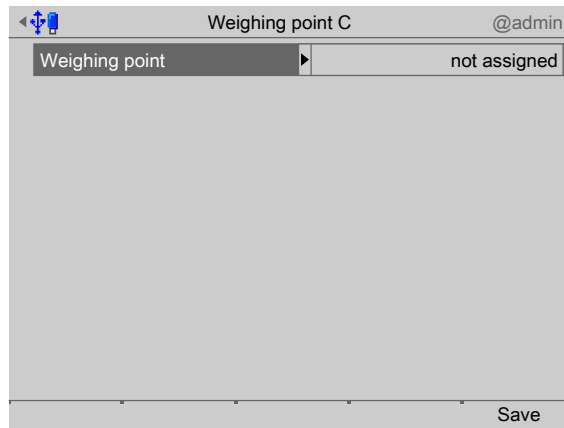

1. Confirm [Weighing point].

▷ A selection window opens.

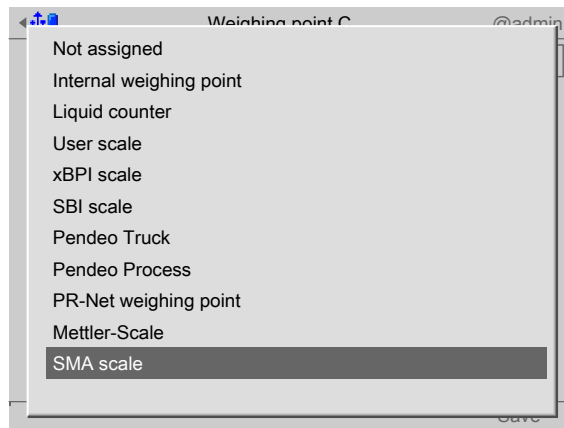

2. Select and confirm [SMA scale].

3. Press the [Save] soft key to save the settings.

▷ The weighing electronics are now assigned to the weighing point.

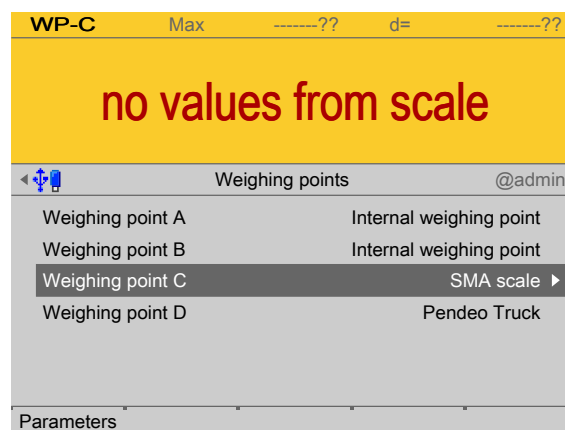

4.7.11.1 Interface (serial)

In this menu item, the parameters of the serial interface for the **SMA scale** weighing electronics are configured.

Accessible via **MENU** - [Operating] - [System setup] - [Weighing points] - [Weighing point x] - [Interface] .

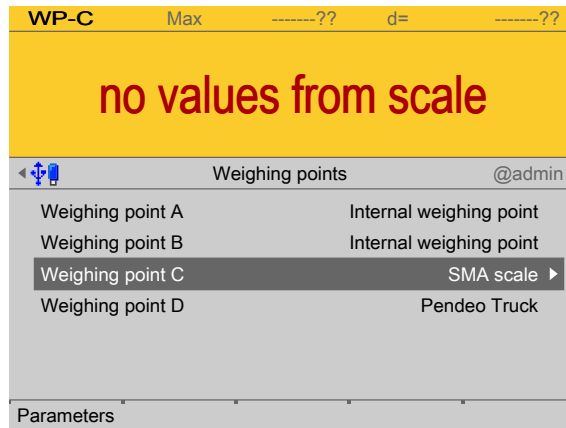

1. In this case: Select and confirm [Weighing point C] with [SMA scale].
 ▷ A selection window opens.

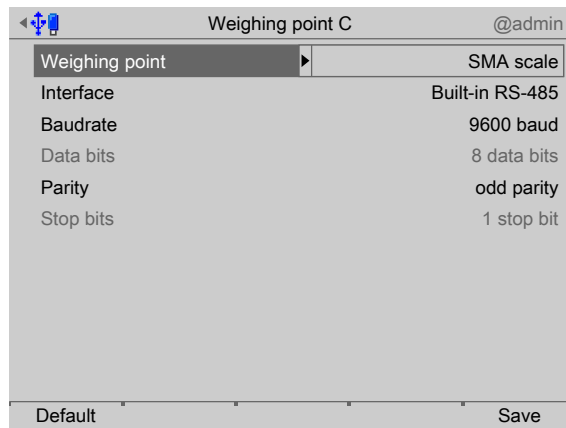

Inactive parameters are grayed out.

2. Select and confirm the individual parameters.

[Interface]

Serial interfaces.

Selection: not assigned, Built-in RS-232, Built-in RS-485, Option-x RS-485-A, Option-x RS-485-B

[Baud rate]

Baud rate of the data transfer.

Note:

The selected value must match the value of the connected device.

Selection: 300, 600, 1200, 2400, 4800, [9600], 19200 baud

[Parity]

Parity check for detecting errors during data transmission.

Selection: no parity, odd parity, even parity

[Default] soft key

Settings are reset to factory settings.

3. Press the [Save] soft key to save the settings.

4.7.11.2 Parameters

In this menu item, the parameters of the **SMA scale** weighing electronics are configured. Accessible via **MENU** - [Operating] - [System setup] - [Weighing points] - [Weighing point x] - [Parameters] .

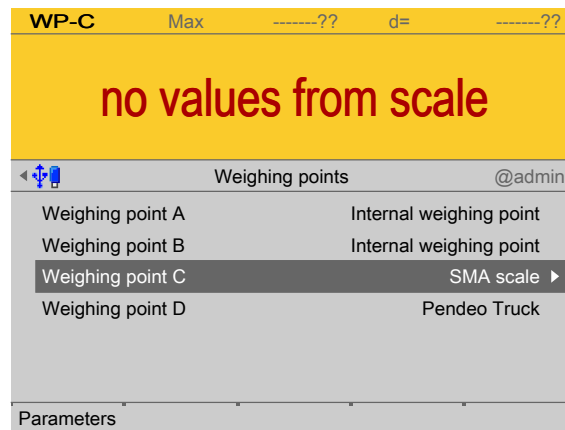

1. In this case: Select [Weighing point D] with [SMA scale] and press the [Parameters] soft key.
 - ▷ A selection window opens.

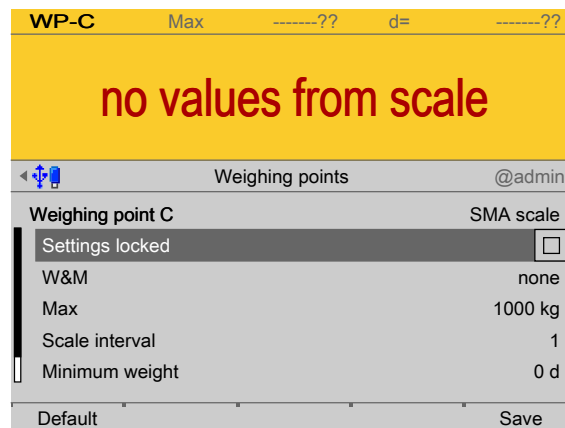

2. Select and confirm the individual parameters.

[Settings locked]

The weighing point settings and assignment can only be viewed as if the corresponding CAL switch were closed; see Chapter [2.7.1](#).

[W&M]

Setting for operation in legal metrology.

Selection: [None], OIML, NTEP (for USA) or NSC (for Australia), see Chapter [4.7.1.1.1](#).

[Max] (maximum capacity)

See Chapter [4.7.1.2.1.1](#).

[Scale interval]

See Chapter [4.7.1.2.1.2](#).

[Min. weight]

Minimum weight at which a print command can be triggered.

Setting range: 0...99999999 d.

For use in legal metrology a value of at least 20 d must be set.

[Update time]

Timeframe in which a new weight value is displayed.

Setting range: 0.1...2.0 s.

[Default] soft key

Settings are reset to factory settings.

3. Press the [Save] soft key to save the settings.

4.8 Display settings

In this menu item (under **System setup**), the display parameters are configured for the luminance of the lighting conditions.

Accessible via **MENU** - [Operating]- [System setup]- [Display settings] .

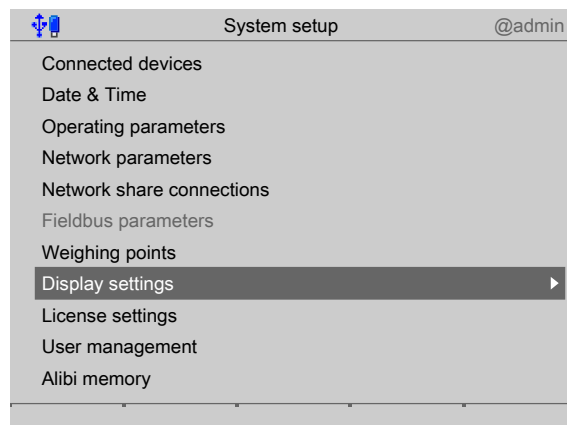

1. Select and confirm [Display settings].

▷ A selection window opens.

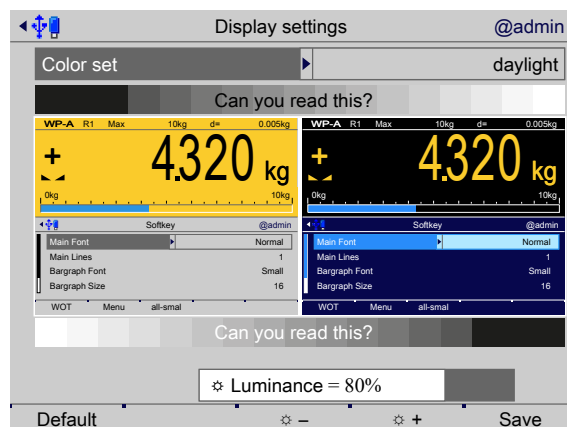

2. Select and confirm the individual parameters.

[Color set]

Selection: [daylight], night shade

[Luminance]

Select: using [5 -] and [5 +] in 5 % steps

[Default] soft key

Settings are reset to factory settings.

3. Press the [Save] soft key to save the settings.

4.9 License settings

In this menu item (under **System setup**), licenses for functions and application programs are activated.

- Function and application licenses can be added, activated, and deleted.
(e.g. [Alibi memory license], [OPC server license], [Dosing license], etc.).
- [Application license], see Chapter [4.9.1](#).
- [Demo mode], see Chapter [4.9.2](#).
- [Default], reset to factory settings, see Chapter [4.9.3](#)

Note:

Licenses cannot be changed if CAL switch 2 is closed or [W&M mode] is selected and the parameter [Settings locked] is activated for at least one weighing point.

Accessible via **MENU** – [Operating] - [System setup] - [License settings].

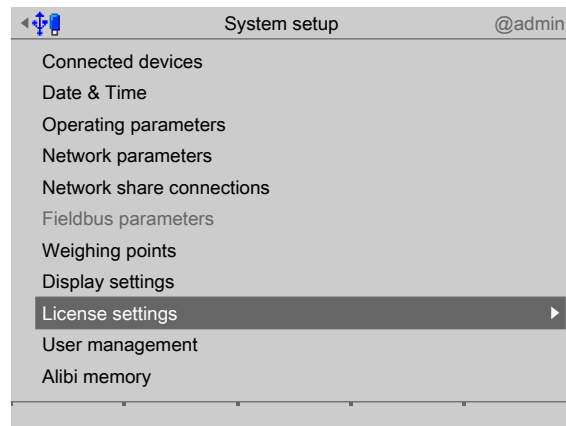

- ▶ Select and confirm [License settings].
 - ▷ The license settings menu opens.

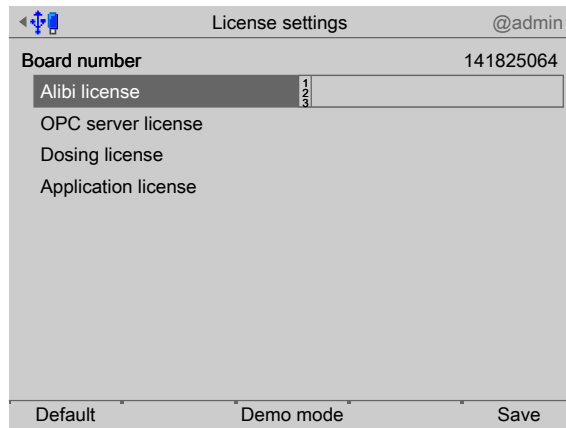

4.9.1 Application license

In this menu item (under **License settings**), the application license is activated.

Accessible via **MENU** - [Operating] - [System setup] - [License settings] - [Application license] .

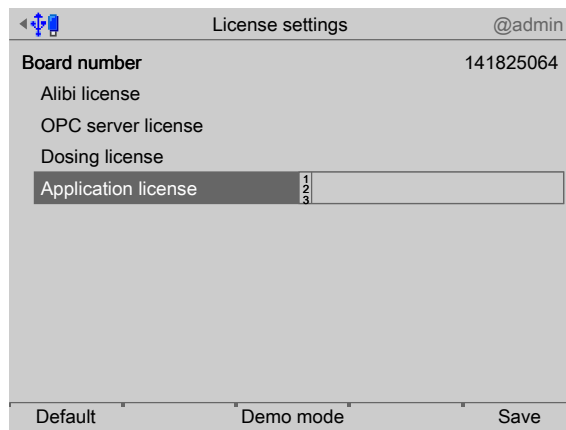

The nine-digit board number is displayed.

1. Select [Application license] and enter the license number as a seven-digit figure using the keyboard.

Note:

License numbers are delivered with the device as a certificate and are valid only for this device/board number.

2. Press the [Save] soft key to save the settings.

4.9.2 Demo mode

In this menu item (under **License settings**), licenses for functions and application programs are activated for demo mode.

Accessible via **MENU** - [Operating] - [System setup] - [License settings] - [Demo mode] .

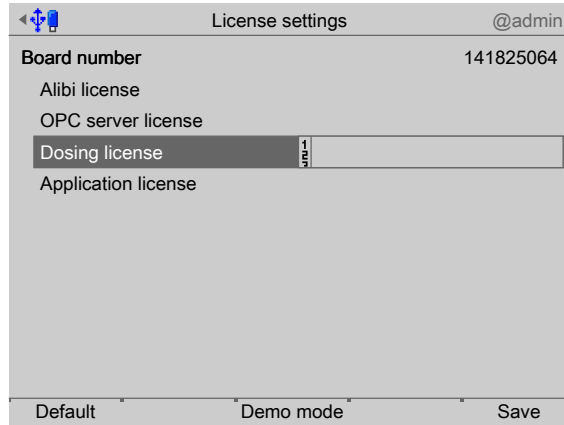

1. Press the [Demo mode] soft key to operate the selected application in demo mode.
 - ▷ A prompt window appears.

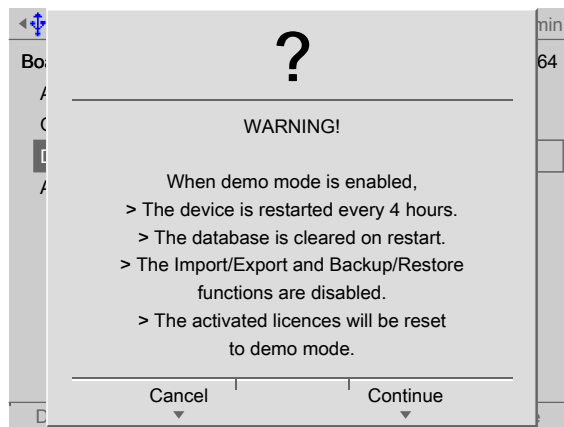

2. Press the [Continue] soft key to start demo mode.
 - ▷ A notification window appears indicating that a cold start will occur; see Chapter [2.2.3](#).

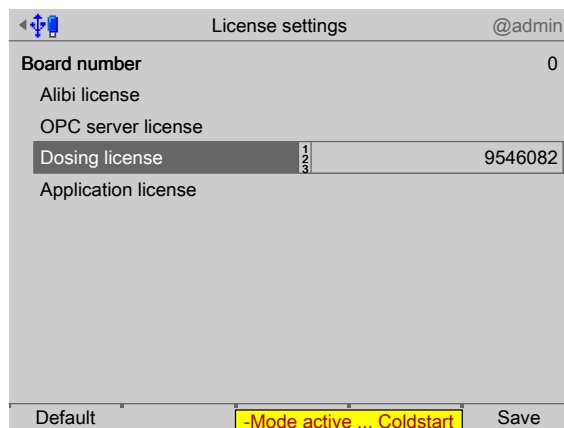

- If demo mode is activated, the corresponding license number (here: example for batching) must be input and confirmed with the [Save] soft key.

Product	License number	Description
PR 5900/91	1550459	Alibi memory license
PR 5900/92	3550167	OPC server license
PR 5900/93	9546082	Dosing license
PR 5900/xx	1786623	Universal license
PR 5900/81	0928277	Phase license
PR 5900/82	6955306	Count license
PR 5900/83	7961243	Batching license
PR 5900/84	0661176	Truck license
PR 5900/86	8965110	IBC license
PR 5900/87	8395383	Basic tilt error license

- The desired batching is carried out.
- To end demo mode, press the [Finish demo] soft key.
 - ▷ The previously entered license number for demo mode is deleted.

The previous board number and license number are rewritten again.

4.9.3 Default (restoring factory settings)

In this menu item (under **License settings**), the license numbers are reset to factory settings.

Accessible via **MENU** - [Operating] - [System setup]- [License settings]- [Default] .

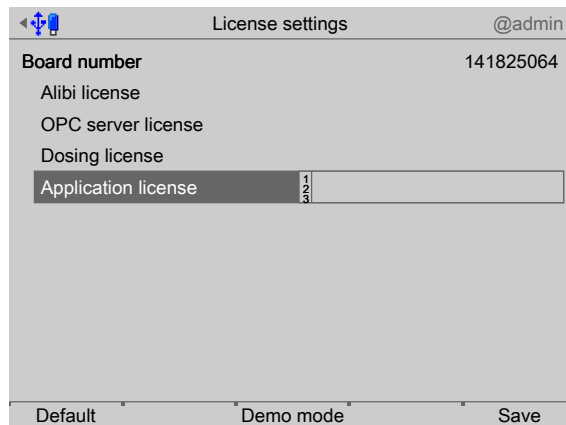

- Press the [Default] soft key.
 - ▷ A prompt window appears.

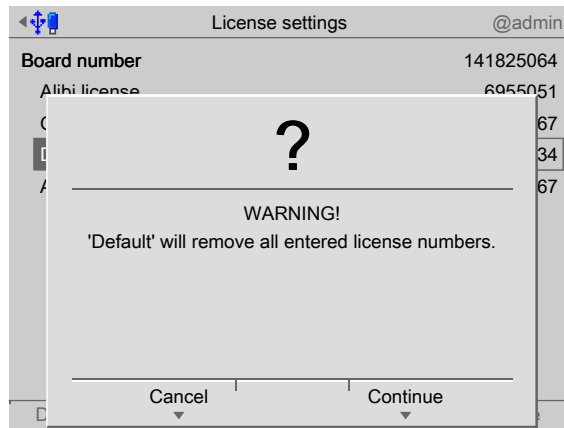

2. Press the corresponding soft key.

4.10 User management

In this menu item (under **System setup**), users are managed or user management is activated (only if the device is being switched on for the first time) or deactivated.

Note:

User management is **deactivated** by default.

If user management is activated and the "admin" user (administrator) is logged in, this user can

- [Create user], see Chapter [4.10.1](#).
- [Copy user], see Chapter [4.10.2](#).
- [Change user settings], see Chapter [4.10.3](#).
- [Remove user], see Chapter [4.10.4](#).
- [Deactivate user management], see Chapter [4.10.5](#).

Accessible via **MENU** – [Operating] - [System setup] - [User management].

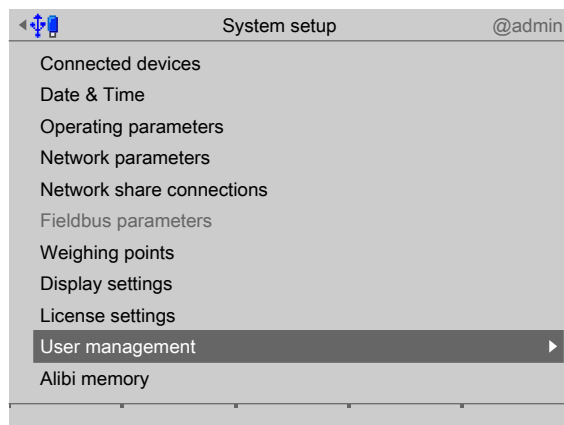

- ▶ Select and confirm [User management].

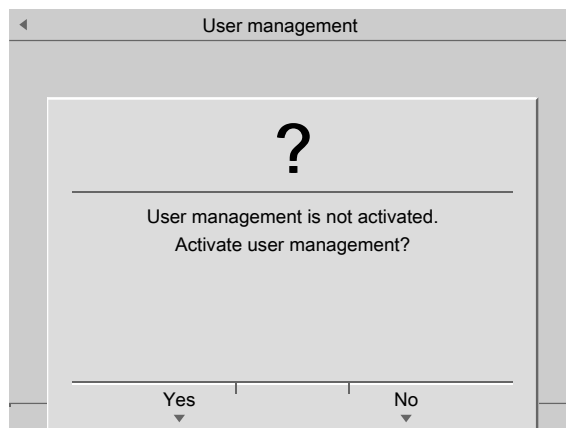
Activate user management:

This prompt window only appears if user management is not activated.

Press the [Yes] soft key to activate user management.

▷ The user management menu opens.

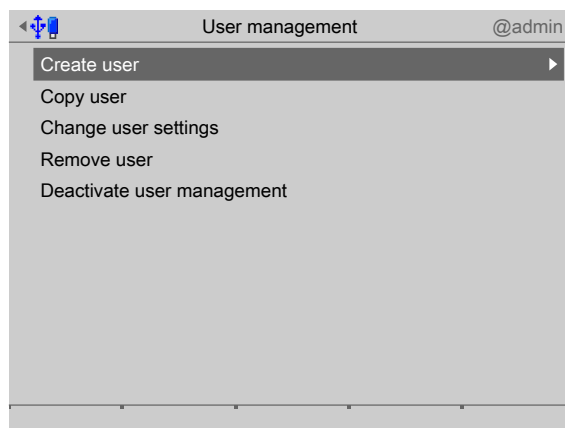

4.10.1 Create user

In this menu item (under **User management**), new users are created and the corresponding parameters are configured.

The users "admin" and "default" are created automatically and cannot be deleted:

- The "admin" user (Administrator) is always created with all rights authorized. These cannot be restricted.
- The "default" user has restricted rights.

Accessible via **MENU** – [Operating] - [System setup] - [User management] - [Create user]

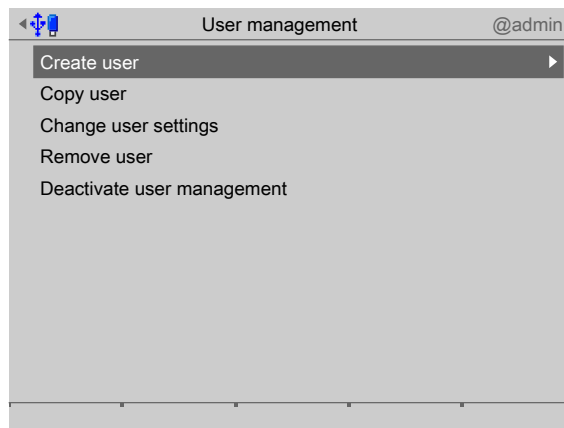

1. Select and confirm [Create user].

▷ An input window opens.

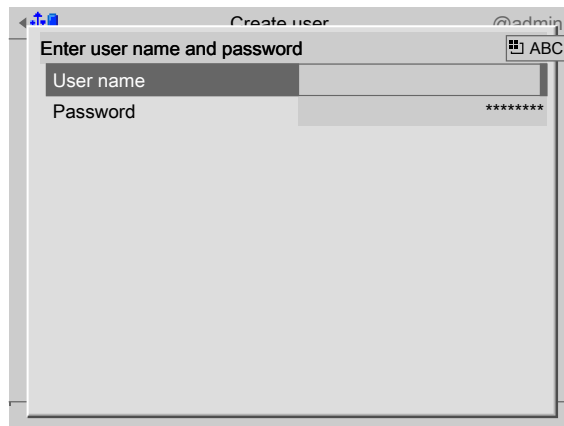

2. Enter the user name using the keyboard and confirm.

Note:

Special characters are not allowed.

Always follow the IT security guidelines.

Default settings: User name: admin, password: admin

3. Enter a password (access code) using the keyboard and confirm.

▷ A selection window opens.

Create user		@admin
User ID		11
User name		operator
User activated	<input checked="" type="checkbox"/>	
Password		*****
Language		System default
Screensaver		Standard system settings
Logout after		no auto logout
Force login after screensaver	<input type="checkbox"/>	
Change user at relogin	<input type="checkbox"/>	
Need password to logout	<input type="checkbox"/>	
		Save

The user name is displayed with an automatically generated user ID.

4. Select and confirm the individual parameters.

[User activated.]

The user (default setting) can log in.

If a deactivated user () logs in, the following error message is shown:

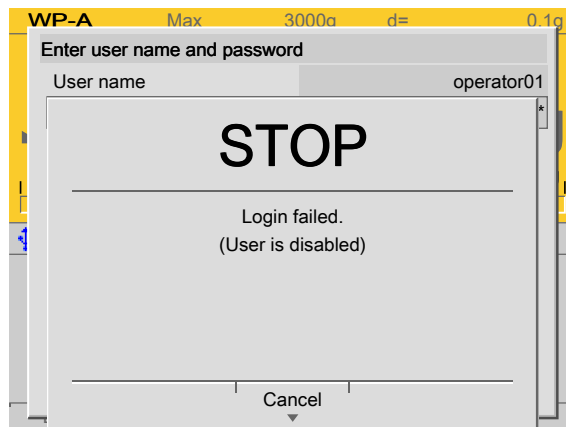

[Password]

The password can be changed here if desired.

[Language]

Select the desired operating language.

[Screensaver]

Selection: [no screensaver], after 1 minute, after 5 minutes, after 10 minutes, after 30 minutes, system default

[Logout after]

Selection: [no auto logout], after 1 minute, after 5 minutes, after 10 minutes, after 30 minutes.

[Force login after screensaver]

Check the box when the screensaver is activated.

Once the screensaver is switched on, operation is only possible once a password has been entered.

[Change user at relogin]

Once the screensaver is switched on, operation is also possible when a different password has been entered.

[Need password to logout]

A password is required in order to log out.

Note:

The administrator can always log in or out even when another user has locked the device with a password.

The screenshot shows a configuration window titled 'Create user' with the user ID '11' and name 'operator'. Under 'System rights', several options are checked:

System right	Checked
Setup	<input checked="" type="checkbox"/>
Import	<input checked="" type="checkbox"/>
Export	<input checked="" type="checkbox"/>
Calibrate	<input checked="" type="checkbox"/>
Operating	<input checked="" type="checkbox"/>
User management	<input checked="" type="checkbox"/>
I/O test	<input type="checkbox"/>
Maintenance	<input checked="" type="checkbox"/>

A tooltip for 'User management' reads: 'User is allowed to use system maintenance functions including software update.' A 'Save' button is at the bottom right.

System rights:**[Setup]**

User is allowed to change settings in the system setup.

[Import]

User is allowed to import data from the USB/SD memory to the device.

[Export]

User is allowed to export data from the device to the USB/SD memory.

[Calibration]

User is allowed to calibrate weighing points.

[Operating]

User is allowed to use indicator keys.

[User management]

User is allowed to create, change, and remove other users.

[I/O test]

User is allowed to start, stop, and test the inputs and outputs.

[Maintenance]

User is allowed to use the system maintenance functions, including software updates.

[Use functions on the website]

User is allowed to use functions on the website.

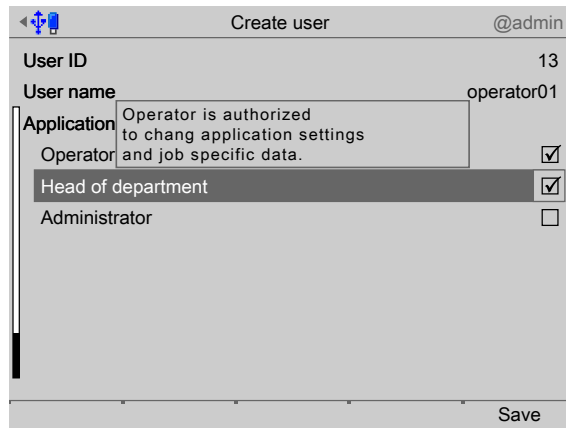

Sample application rights:

Note:

See corresponding application manual.

[Operator]

User is permitted to start weighing and change order-specific data.

[Supervisor]

User is permitted to change application settings and order-specific data.

[Administrator]

User is permitted to change firmware/application settings and order-specific data.

[Simulation]

User is permitted to simulate tipping error correction.

5. Press the [Save] soft key to save the settings.

4.10.2 Copy user

In this menu item (under **User management**), one or more users are created with the same rights.

Accessible via **MENU** - [Operating]- [System setup]- [User management]- [Copy user] .

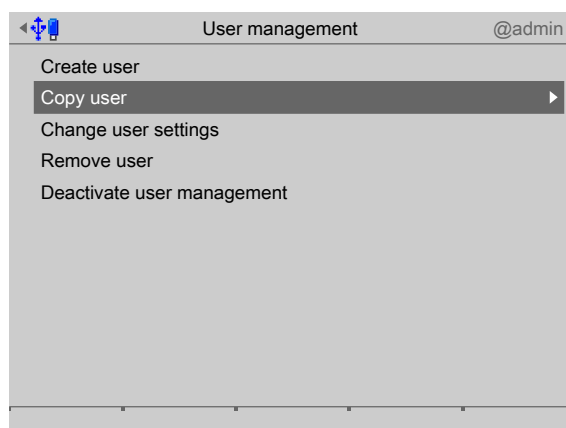

1. Select and confirm [Copy user].
 - ▷ A selection window opens.

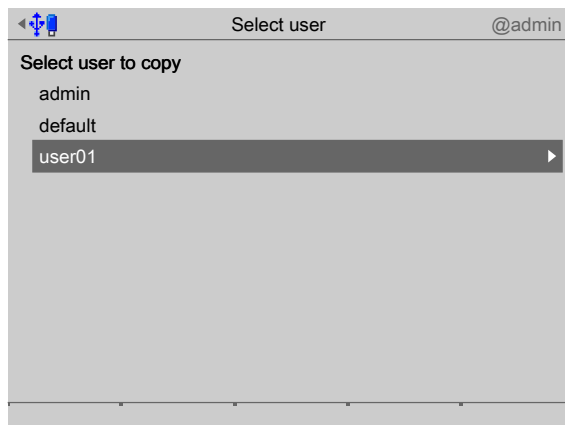

2. Select and confirm the appropriate user.
 - ▷ An input window opens.
3. Enter user name and password and confirm, see also Chapter [4.10.1](#).
4. Change the user settings if necessary, see Chapter [4.10.3](#).
5. Press the [Save] soft key to save the settings.

4.10.3 Change user settings

In this menu item (under **User management**), the parameters for existing users are changed.

Accessible via **MENU** - [Operating]- [System setup]- [User management]- [Change user settings] .

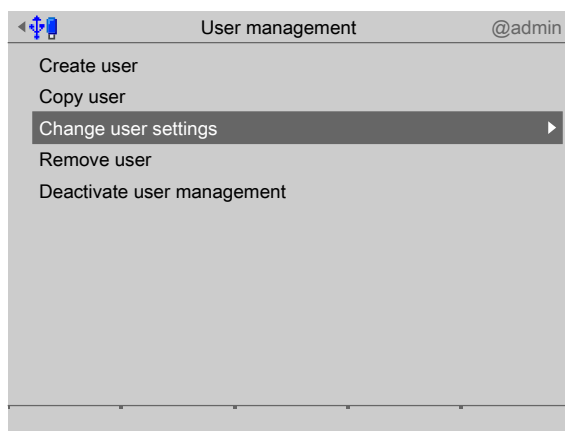

1. Select and confirm [Change user settings].
 - ▷ A selection window opens.

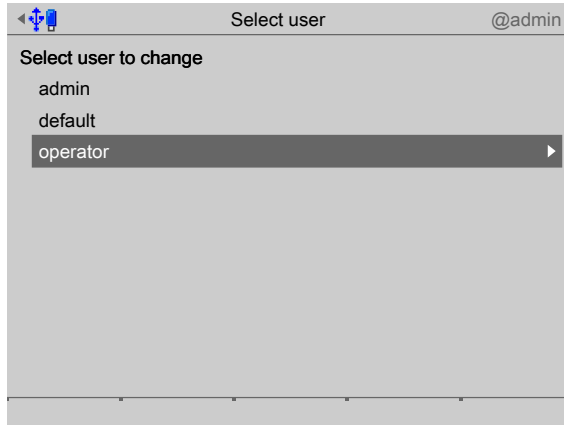

2. Select and confirm the appropriate user.

If the changes are made by the user "admin", only one entry is required for changing passwords.

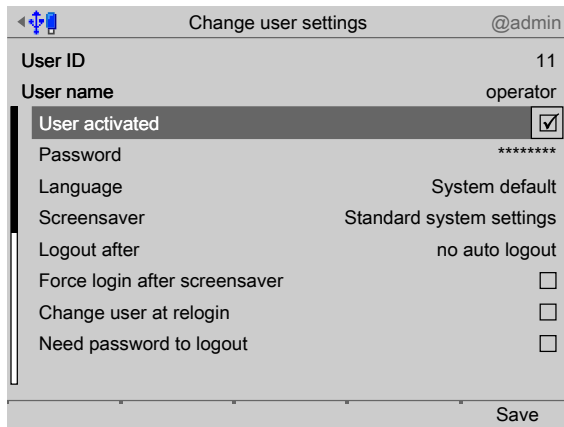

If the changes are made by another user, two entries are required for changing passwords.

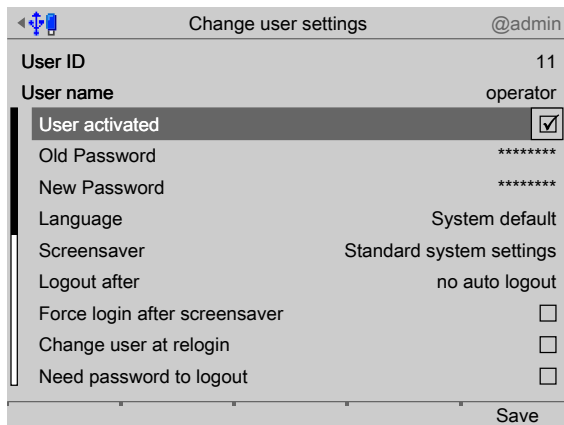

3. Change the corresponding parameters; see also Chapter [4.10.1](#).
4. Press the [Save] soft key to save the changes.

4.10.4 Remove user

In this menu item (under **User management**), one or more users are removed/deleted from user management.

Note:

Users "admin" and "default" **cannot be deleted!**

Accessible via **MENU** - [Operating] - [System setup] - [User management] .

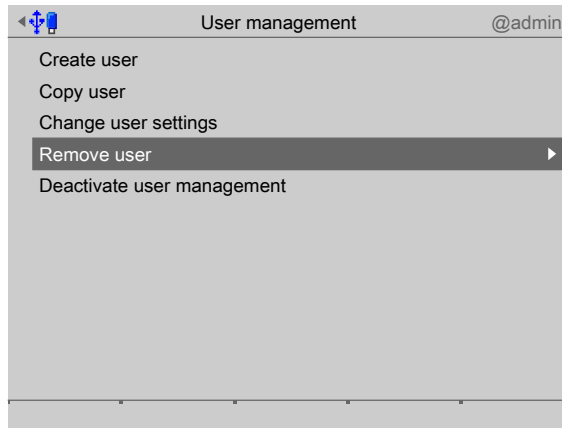

1. Select and confirm [Remove user].

▷ A selection window opens.

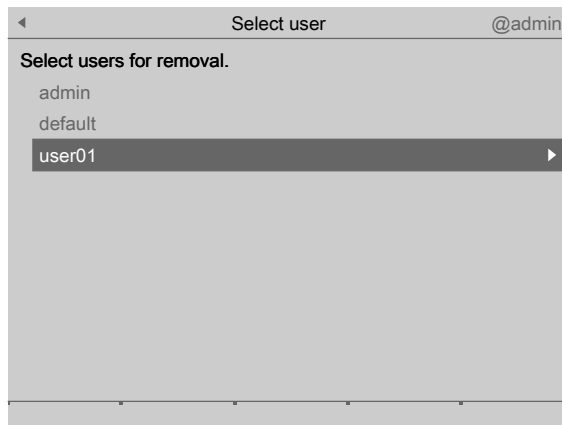

2. Select and confirm the appropriate user.

▷ A prompt window appears.

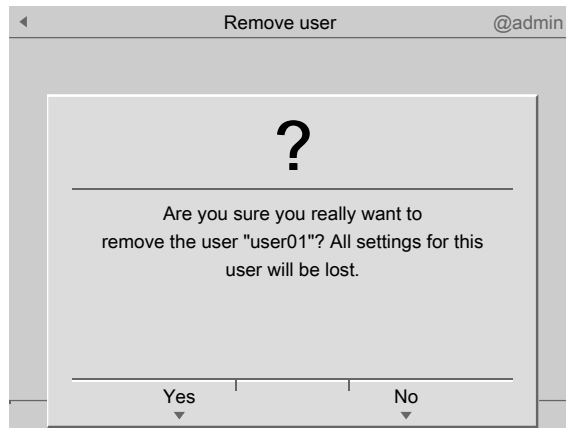

3. Press the corresponding soft key.
4. Press the [Save] soft key to save the settings.

4.10.5 Deactivate user management

In this menu item, **User management** is deactivated.

Note:

User management may only be deactivated by the "admin" user.

Accessible via **MENU** - [Operating]- [System setup]- [User management]- [Deactivate user management] .

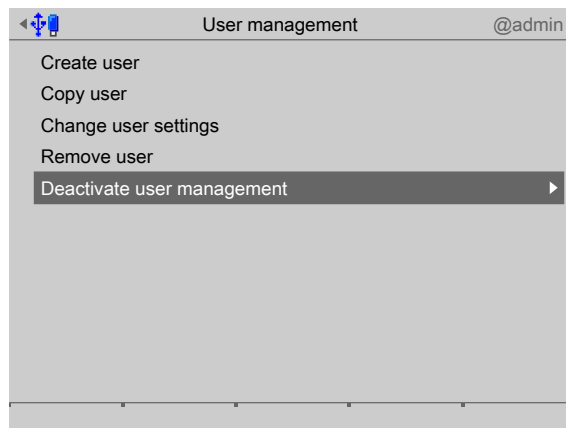

1. Select and confirm [Deactivate user management].
 - ▷ A prompt window appears.

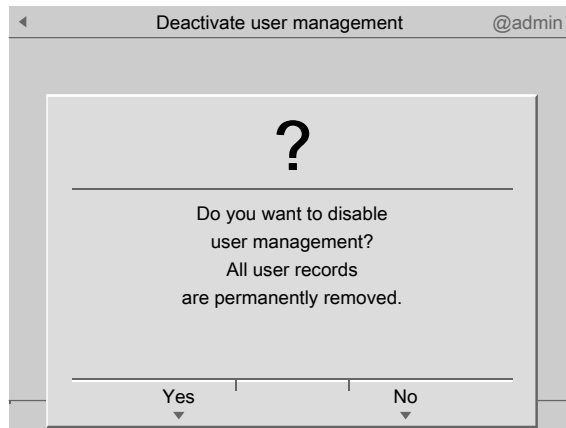

2. Press the corresponding soft key.

4.10.6 Error logging in

If the admin user password has been lost, the master password "202122" can be used to open a password unlock window.

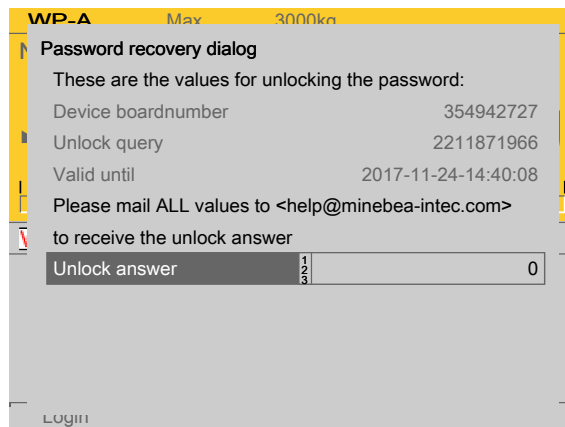

The following steps must be taken in order to unlock the password.

1. Take a screenshot of the password unlock window via the website, copy and paste into an e-mail message, and send to "help@minebea-intec.com".
 - ▷ A generated response will be sent.

Response from help@minebea-intec.com

Body of the e-mail		Description
Generated unlock data		
Time stamp	"yyyymmdd-hhmmss"	Manufacturer information: Date and time of generated response
Remote user	"xxxxx.xxxxx"	Manufacturer information: Edited by

Body of the e-mail		Description
customer	"Mr. X. Ample"	Customer name
company	"Example Company"	Company name
contact	"xxxxx.xxxxx@xxxxx.com"	E-mail address
board number	"xxxxxxxxx"	Board number
unlock query	"xxxxxxxxxx"	Unlock query
valid until	"yyyy-mm-dd-hh:mm:ss"	valid until: date and time
response	"xxxxxxxxxxx"	Unlock answer

- The unlock answer can be found in the "response" line of the e-mail.

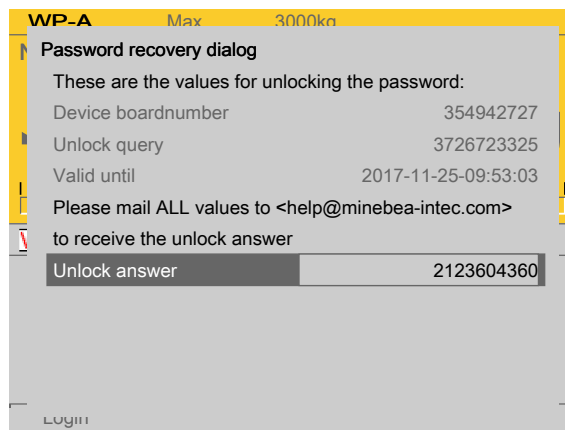

- Enter the 10-digit number sequence in the "Unlock answer" field in the password unlock window and confirm.

▷ The following window opens:



- Change the administrator password, see Chapter [4.10.3](#).

4.11 Alibi memory

In this menu item (under **System setup**), the parameters for the conditions for a full Alibi memory are configured.

- [Tidy up records] (conditions for automatic overwrite), see Chapter [4.11.1](#).
- [Delete] (complete Alibi memory), see Chapter [4.11.2](#).

Note:

A license is required for this function; see Chapter 4.9.

If CAL switch 1 is closed or if the parameters [W&M] and [Settings locked] are set for a weighing point, the Alibi memory cannot be deleted and the settings are not changed.

The Alibi memory must be set before verifying the weighing points!

Accessible via **MENU** - [Operating]- [System setup]- [Alibi memory] .

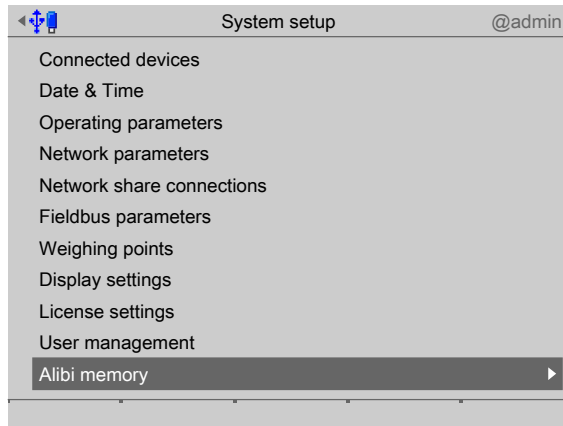

▶ Select and confirm [Alibi memory].

▷ The Alibi memory menu is displayed.

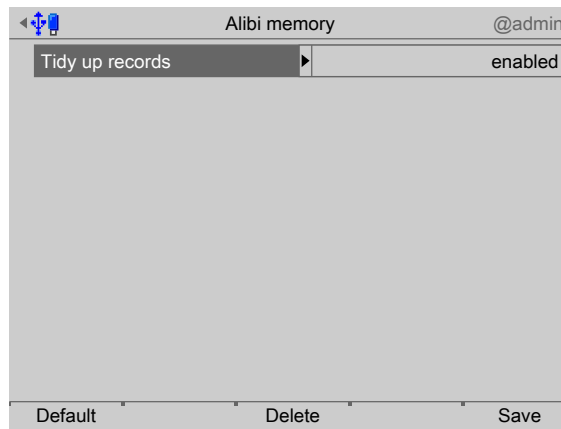

4.11.1 Tidy up records

In this menu item (under **Alibi memory**) it is determined how individual records are to be automatically overwritten if the Alibi memory is full.

Accessible via **MENU** - [Operating] - [System setup] - [Alibi memory] - [Tidy up records] .



1. Confirm [Tidy up records].

If the Alibi memory is full:

- [enabled], the oldest record is automatically overwritten.
- [disabled], records must be deleted manually.
- [by age], the minimum age a record must be before it is automatically overwritten.

▷ A selection window opens.



2. In this case: select and confirm [by age].

▷ An input window opens.

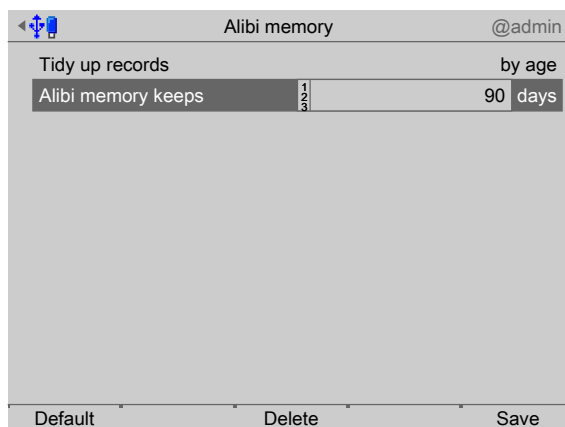

3. Enter the number of days to indicate how old a record must be in order to be automatically overwritten.
4. Confirm the entry.
5. Press the [Save] soft key to save the settings.

Note:

If the [Default] soft key is pressed, the minimum age of a record is reset to the default value (90 days).

4.11.2 Delete

In this menu item (under **Alibi memory**), the entire Alibi memory is manually deleted. Accessible via **MENU** - [Operating] - [System setup] - [Alibi memory] - [Delete] .

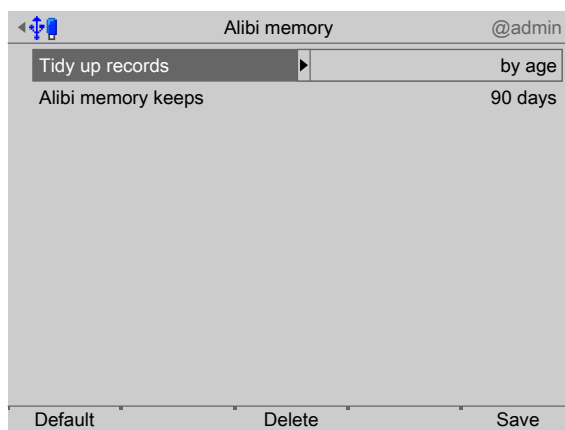

1. Press the [Delete] soft key to delete the entire Alibi memory manually.
 - ▷ A prompt window appears.



2. Press the [Continue] soft key to confirm the manual deletion of the Alibi memory.

5 System information

In the system information menu (under **System menu**), information on the system is displayed.

- [Show version], see Chapter 5.1.
- [Show status], see Chapter 5.2.
- [Show alarm information], see Chapter 5.3.
- [Show HW options] (hardware options), see Chapter 5.4.
- [Show ModBus-TCP I/O module], see Chapter 5.5.
- [Browse the Alibi memory], see Chapter 5.6.
- [Show calibration check number], see Chapter 5.7.
- [Show Pendeo data], see Chapter 5.8.
- [Show event log], see Chapter 5.9.
- [Print configuration settings], see Chapter 5.10.

Accessible via **MENU** - [Operation]- [System information] .

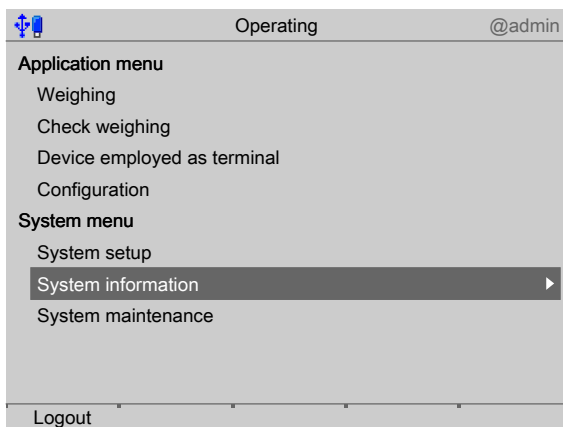

► Select and confirm [System information].

▷ The System information menu opens.

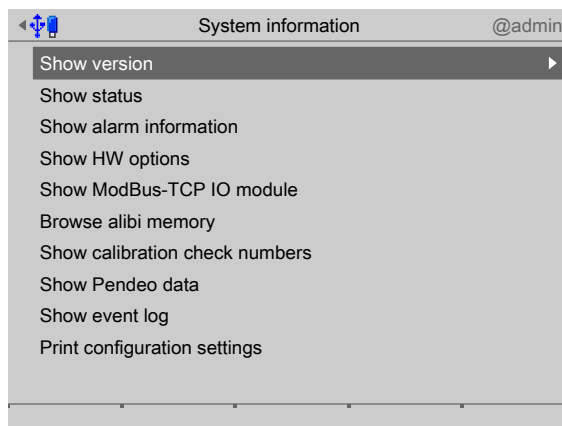

5.1 Show version

In this menu item (under **System information**), information on the version numbers and creation date is displayed.

Accessible via **MENU** - [Operating] - [System information]- [Show version] .

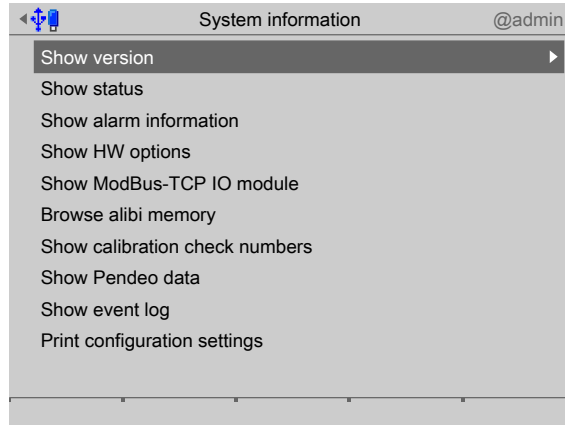

1. Confirm [Show version].

▷ The following information is displayed.

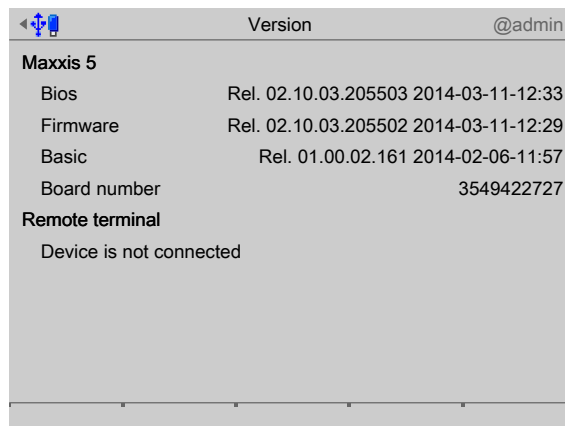

Maxxis 5

[Bios]

Version number and BIOS creation date

[Firmware]

Version number and firmware creation date

[Basic]

The corresponding application name, version number and creation date of the application is displayed here

[Board number]

Nine-digit board number

Remote terminal

In this case: Device is offline

2. Press **EXIT** to return to the previous window.

5.2 Show status

In this menu item (under **System information**), information on the device statuses is displayed.

Accessible via **MENU** – [Operating] - [System information] - [Show status] .

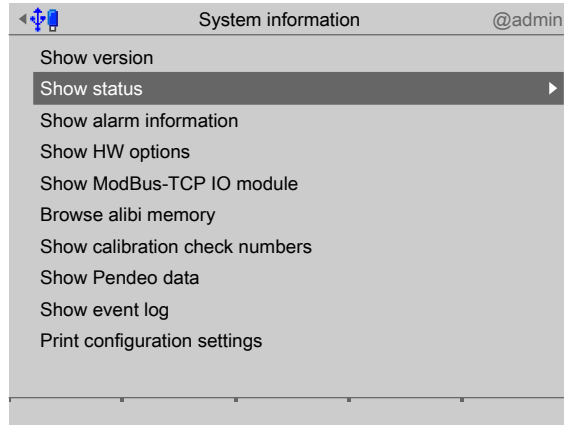

1. Select and confirm [Show status].

▷ The following device statuses are displayed.

	Version	@admin
Available system RAM		11728/27188 kB
Available backup memory		3759/3775 MB
Available settings memory		1484/2048 kB
Available database memory		1791/1792 kB
Clock battery status		battery is ok
Board temperature		39.00 °C
Accu status		ok
Accu charge		inactive
CAL switch A/B		opened/opened
CAL switch 1/2		opened/opened

[Available system RAM]

Free working system memory space

[Available backup memory]

Free memory for backups

[Available settings memory]

Free memory for settings

[Available database memory]

Free database memory

[Clock battery status]

Battery status

[Board temperature]

Main board temperature

[Battery status]**[Battery charging]**

Alarm at

- Temperatures > 60°C: The standby battery is too hot and charging will not take place. If this does not go away, the ambient temperature must be checked, see PR 5900 installation manual under [Technical data] - [Environmental influences] - [Ambient conditions] .
- Overloading
- < min. voltage

[Status battery capacity]

Display of charge strength (mA)

[CAL switch A/B]

Only appears if the corresponding option is installed. Otherwise, "n/a" (not applicable) is displayed.

Status display

[CAL switch 1/2]

Status display

2. Press **EXIT** to return to the previous window.

5.3 Show alarm information

In this menu item (under **System information**), information on the existing system messages is displayed.

Accessible via **MENU** - [Operating] - [System information]- [Show alarm information] .

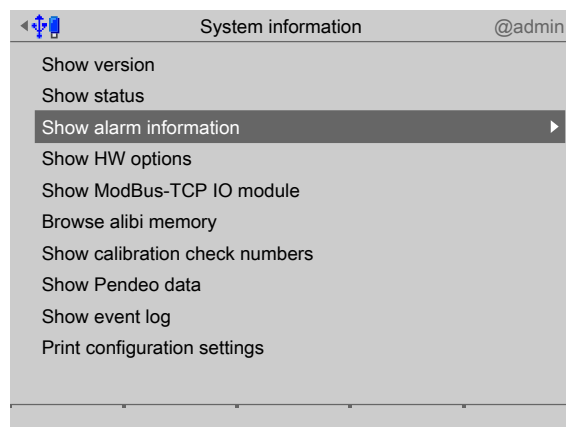

1. Select and confirm [Show alarm information].
 - ▷ The existing system messages are displayed.

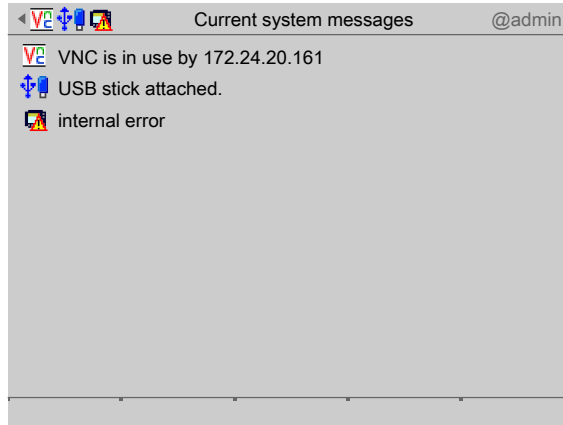

2. Press **EXIT** to return to the previous window.

5.4 Show HW options

In this menu item (under **System information**), information on the installed hardware options is displayed.

Accessible via **MENU** - [Operating] - [System information]- [Show HW options] .

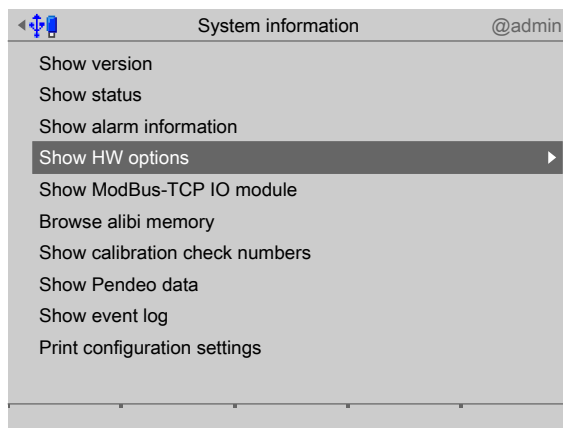

1. Select and confirm [Show HW options]
 - ▷ The installed hardware options are displayed.

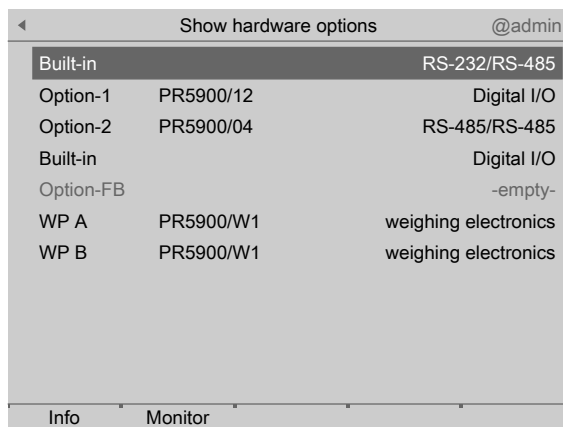

Inactive options are grayed out.

Note:

Option cards not recognized by the system are displayed as follows:

PR xxxx/xx, unsupported option

Option cards detected by the system but not recognized by it are displayed as follows:

Information could not be read -assigned-

2. Select option and press the [Info] soft key.

▷ Information on the option card is displayed.

Built-in		@admin
Option type	PR5900/00 Rev 99	
Serial number	1011-104711-000123	
Production date	01.01.0000	
Production location	SAG-HH	

3. Press **EXIT** to return to the previous window.

4. Press the [Monitor] soft key.

▷ The current values are display, e.g., internal RS-232 interface.

Built-in		@admin
RS-232		
Status	is in use	
Tx character in bytes	14295375	
Rx character in bytes	275	
Breaks	273	
Overrun errors	0	
Parity errors	2	
Framing errors	0	
RS-232	RS-485	

5. Press the [RS-485] soft key to display the current values for the internal RS-485 interface.

6. Press **EXIT** to return to the previous window.

5.5 Show ModBus-TCP I/O module

In this menu item (under **System information**), the I/O modules of a ModBus-TCP master of an active application are monitored.

Accessible via **MENU** - [Operating] - [System information] - [Show ModBus-TCP IO module] .

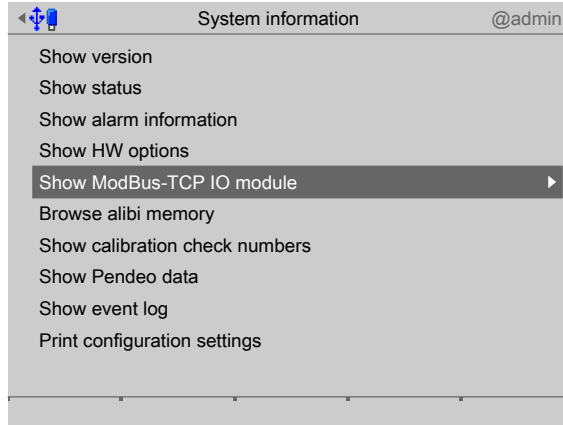

1. Select and confirm [Show ModBus-TCP IO module].

▷ The modules and their status are displayed.

The screenshot shows the same terminal window, but now displaying a table of Phoenix Modules. The table has three columns: an index number, the module name, and its status. Row 7 is highlighted.

Index	Module Name	Status
1	Phoenix Module 1	Not linked
2	Phoenix Module 2	Not linked
3	Phoenix Module 3	Not linked
4	Phoenix Module 4	Not linked
5	Phoenix Module 5	Not linked
6	Phoenix Module 6	Not linked
7	Phoenix Module 7	I/O data active
8	Phoenix Module 8	Not linked

2. Select and confirm the corresponding module.

▷ The following information is displayed.

ModBus-TCP Master		@admin
Phoenix Module 7		172.24.22.7
I/O data active		13.09.2013-14:26:15
connection counter		42
I/O cycles		368
cycle time		0.055 s
Rd	HREGS 8000:	0000
Wr	HREGS 8001:	0000 0000 0000 0000

[Phoenix Module 7]

IP address

[I/O data active since]

Date and time connection last made

[Connection counter]

Counts every connection.

[I/O cycles]

Counts every data exchange.

[Cycle time]

Indicates how often a data exchange takes place (here: every 0.055 s). The exchanged data is shown on the following lines with the registration number.

3. Press **EXIT** to return to the previous window.

5.6 Browsing the Alibi memory

In this menu item (under **System information**), the Alibi memory is searched.

The following options are available:

- [Search for specific date in Alibi memory], see Chapter [5.6.1](#).
- [Search for a given sequence number], see Chapter [5.6.2](#).
- [Status Alibi memory], see Chapter [5.6.3](#).

Accessible via **MENU** - [Operating] - [System information] - [Browse Alibi memory] .

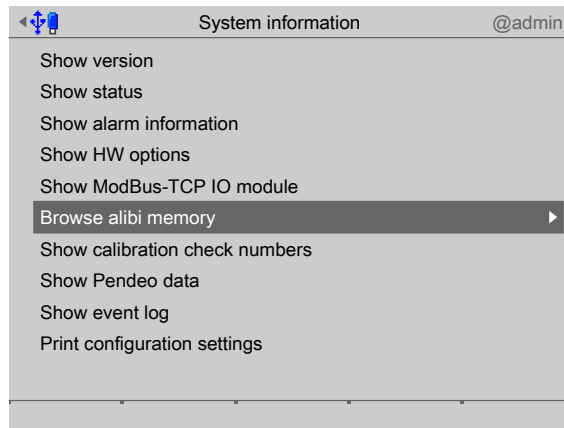

- ▶ Select and confirm [Browse Alibi memory].
- ▷ The Alibi memory menu is displayed.

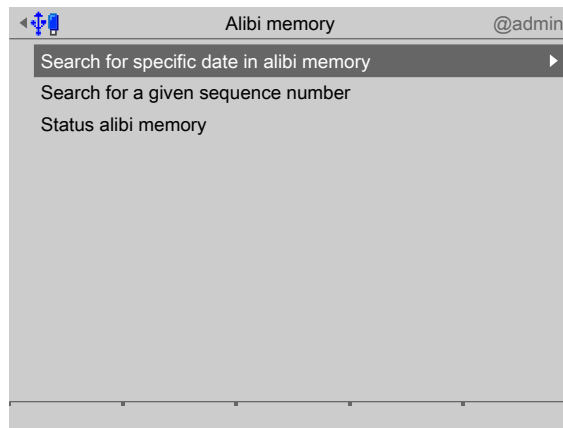

5.6.1 Search for specific date in Alibi memory

In this menu item (under **Alibi memory**), the Alibi memory is searched by a specific date. Accessible via **MENU** - [Operating] - [System information] - [Browse Alibi memory] - [Search for specific date in Alibi memory] .

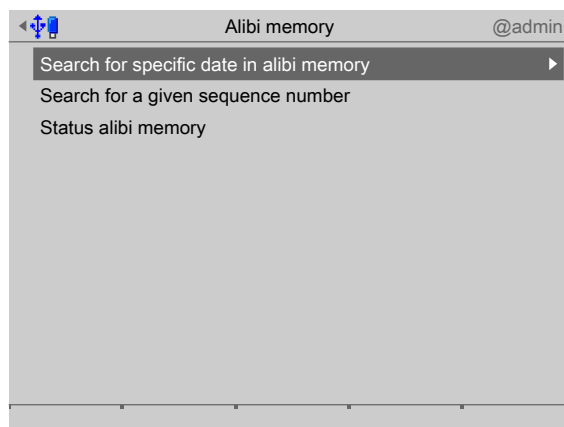

1. Select and confirm [Search for specific date in Alibi memory].

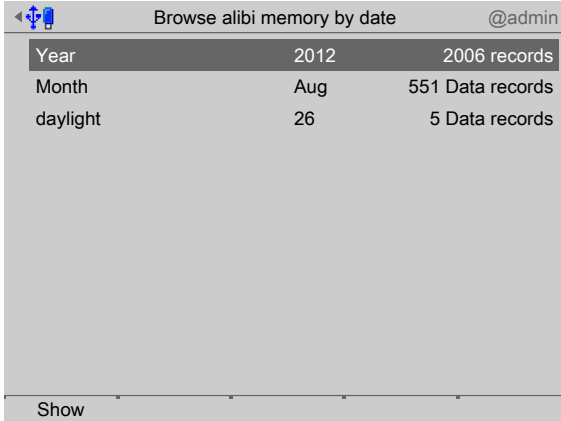

Year	2012	2006 records
Month	Aug	551 Data records
daylight	26	5 Data records

Show

2. Select and confirm [Year].

▷ A selection window opens.



Year	2012	2006 records
Year 2012		2006 records
Year 2013		6 Data records

Show

3. Select and confirm the desired year.

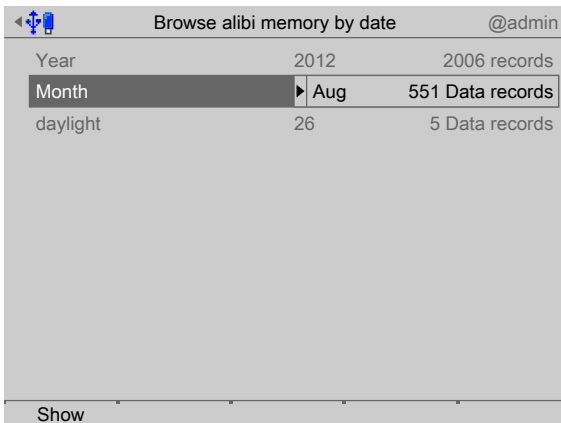

Year	2012	2006 records
Month	▶ Aug	551 Data records
daylight	26	5 Data records

Show

4. Select and confirm [Month].

▷ A selection window opens.

Month	Records
08.2012	551 records
09.2012	811 Data records
10.2012	222 Data records
11.2012	206 Data records
12.2012	216 Data records

5. Select and confirm the desired month.

Filter	Year	Records
Year	2012	2006 records
Month	Aug	551 Data records
daylight	26	5 Data records

6. Select and confirm [Day].

▷ A selection window opens.

Date	Records
10.08.2012	291 records
11.08.2012	724 Data records
12.08.2012	725 Data records
13.08.2012	714 Data records
14.08.2012	761 Data records
15.08.2012	706 Data records
16.08.2012	738 Data records
17.08.2012	714 Data records
18.08.2012	728 Data records
19.08.2012	719 Data records
20.08.2012	725 Data records
21.08.2012	734 Data records

7. Select and confirm the desired day.

8. Press the [Show] soft key.

▷ The corresponding record is displayed.

Browse alibi memory by date		@admin
10.08.2012		[291/291]
Date/Time	10.08.2012-18:19:41	
Sequence number	20002	
WP serial number	47110815	
ID	TEST-3/2000	
G	1014.8 g	
NET	-2089.7 g	
T	-1074.9 g	

Previous Next -10 +10

9. Use the appropriate soft keys to scroll through the individual records.
10. Press **EXIT** to return to the previous window.

5.6.2 Search for a given sequence number

In this menu item (under **Alibi memory**), the Alibi memory is searched for a specific sequence.

Accessible via **MENU** - [Operating]- [System information]- [Browse Alibi memory]- [Search for a given sequence number] .

Alibi memory		@admin
Search for specific date in alibi memory		
Search for a given sequence number ▶		
Status alibi memory		

1. Select and confirm [Search for a given sequence number].
- ▷ A selection window opens.

Alibi memory		@admin
?		
Enter sequence number		
<input type="text" value="2"/>		
Ok		

2. Enter the sequence number.
3. Press the [OK] soft key.

▷ The corresponding record is displayed.

Alibi memory		@admin
Date/Time	27.08.2012-11:22:10	
Sequence number	2	
WP serial number	390050332	
ID		
G	A	<2834.9 g>
NET	A	<2516.5 g>
T	A	318.4 g

Previous Next -10 +10

4. Use the appropriate soft keys to scroll through the individual records.
5. Press **EXIT** to return to the previous window.

5.6.3 Status Alibi memory

In this menu item (under **Alibi memory**), the status of the Alibi memory is displayed. Accessible via **MENU** - [Operating]- [System information]- [Browse Alibi memory]- [Status Alibi memory] .

Alibi memory		@admin
Search for specific date in alibi memory		
Search for a given sequence number		
Status alibi memory ▶		

1. Select and confirm [Status Alibi memory].
- ▷ The status information of the Alibi memory is displayed.

Status alibi memory		@admin
Records stored	2	
First record	27.08.2012-11:17:04	
Last record	27.08.2012-11:22:10	
Used memory	0.00 %	
Estimated free records	183499	
Keep records for	13 days	
Memory full at	09.09.2012	
Remaining days before full	13	
Est. allowed records/day	14115.3	

2. Press **EXIT** to return to the previous window.

5.7 Show calibration check number

In this menu item (under **System information**), the calibration check numbers of the individual weighing points are displayed.

Accessible via **MENU** – [Operating] - [System information] - [Show calibration check number].

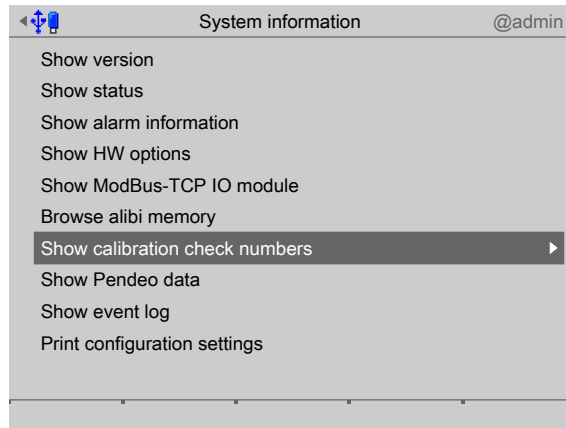

1. Select and confirm [Show calibration check numbers].

▷ The current check numbers of the weighing points are displayed.

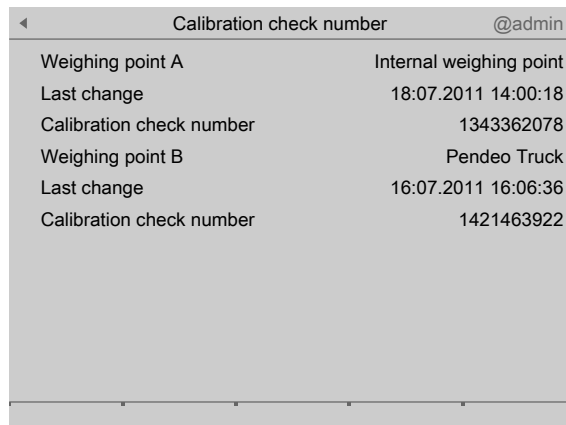

The screenshot shows a screen titled 'Calibration check number' with the user '@admin' in the top right corner. The screen displays the following information:

Weighing point	Type	Last change	Calibration check number
Weighing point A	Internal weighing point	18.07.2011 14:00:18	1343362078
Weighing point B	Pendeo Truck	16.07.2011 16:06:36	1421463922

2. Press **EXIT** to return to the previous window.

5.8 Show Pendeo data

In this menu item (under **System information**), information on the Pendeo load cells is displayed.

Accessible via **MENU** - [Operating] - [System information] - [Show Pendeo data] .

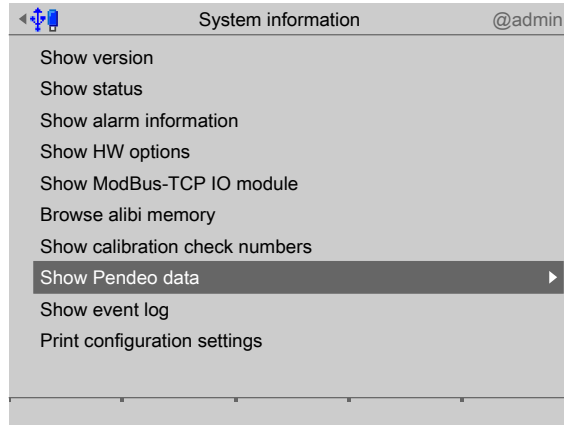

1. Select and confirm [Show Pendeo data]

▷ A selection window opens.

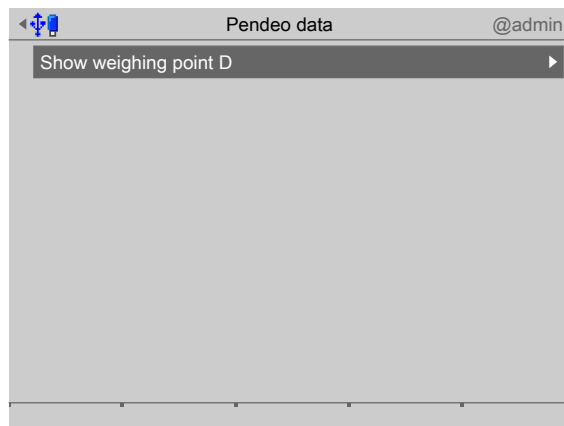

2. Select and confirm the desired weighing point.

▷ An information window is displayed.

The screenshot shows a window titled 'Show load cell weight' with a user icon and '@admin' on the right. It displays the following information:

- Zero correction: 0.00000 t
- Communication error count: 8

LC 1	101	1.430 t	Red		
LC 2	102	2.364 t	Green		
LC 3	103	1.600 t	Red		
LC 4	104	2.109 t	Green		

At the bottom, there is a footer with 'Info' and 'by name'.

[Zero correction]

The zero point correction in use is displayed.

[Communication error counter]

The communication errors (timeouts) for the load cells are counted here in ascending order and displayed.

[LC1...n]

Bar graph display

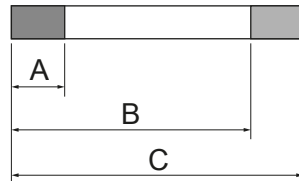

The bar graph shows three areas:

- **A**
Dead load (can be changed by calibration)
- **B**
Maximum capacity E_{max} (max. capacity of load cell) including dead load (load cell, cannot be changed)
- **C**
Max. usable load including dead load (load cell, cannot be changed)

The colors have the following meanings:

- **Red**
Weight value is above maximum capacity (overload) or below $-1/4d$
- **Green**
Weight value is within tolerances
- **Orange**
Weight value is above maximum capacity E_{max} (max. capacity of load cell)

3. Select the desired load cell and press the [Info] soft key.

▷ The load cell data is displayed:

[Info] soft key

Load cell info		@admin
Model name	PR6204/50tC3	
Software version	1.00.04	
LC serial number	101	
E_{max}	50.0 t	
n	3000 e	
Y	14000	
Z	3000	
Overload	75.0 t	
Overload counter	0	
Temperature	26.6 °C	
Max. temperature	36.6 °C	
Min. temperature	26.4 °C	

Display	Description
E _{max}	Maximum capacity
n	Max. resolution
Y	Minimum LC verification
Z	Minimum preload signal recurrence
Overload	Weight value above max. usable load
Overload counter	Number of weight values above max. usable load. The higher the number, the higher the probability of a faulty load cell.
Temperature	Current measured temperature
Max. temperature	Max. measured temperature
Min. temperature	Min. measured temperature
Max. weight value at	Date and time display Time of largest load on load cells
Max. weight value	Display

Show load cell weight		@admin
Zero correction		0.00000 t
Communication error count		40
PR 6204-RU	1.411 t	■
PR 6204-RO	2.383 t	■
PR 6204-LO	1.580 t	■
PR 6204-LU	2.129 t	■

Info by ID

[by name] soft key

If names are assigned in the menu [System setup]- [Weighing point]- [Calibration]- [Assign load cell names] , they are displayed.

[by ID] soft key.

Display the item number of the load cells.

4. Press **EXIT** to return to the previous window.

5.9 Show event log

In this menu item (under **System information**), the event logs for the following areas are displayed:

- [System setup] (e.g.: user login and logout, calibration, etc.)
- [Device] (e.g.: search for Pendeo load cells)
- [Switch on/off] (e.g.: switch device on/off)

Accessible via **MENU** - [Operating] - [System information]- [Show event log] .

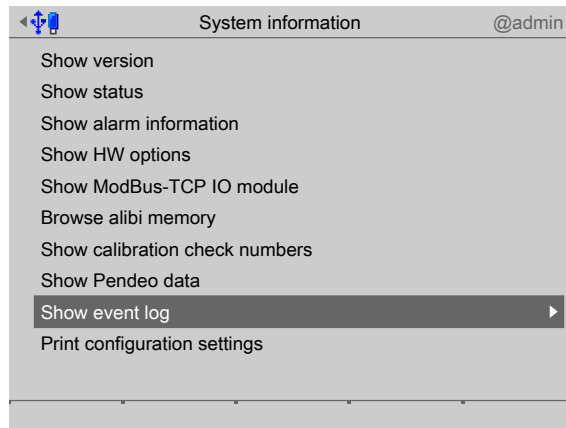

1. Select and confirm [Show event log]

▷ A selection window opens.

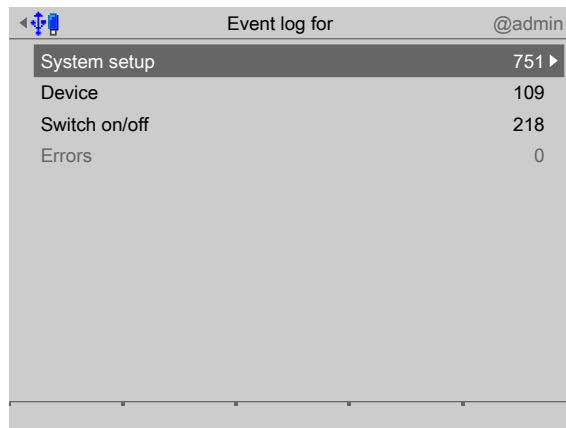

2. Select and confirm the desired menu item, e.g. System setup.

▷ The log is displayed.

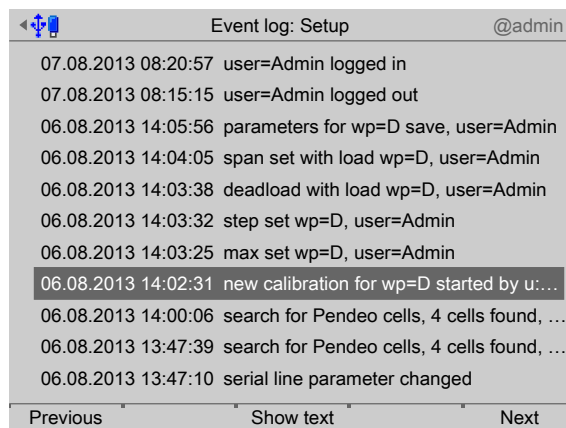

3. If desired, press the [Previous]/[Next] soft key to scroll through the individual lines of the log.

4. If desired, press the [Show text] soft key to display the entire text.

▷ An information window is displayed.

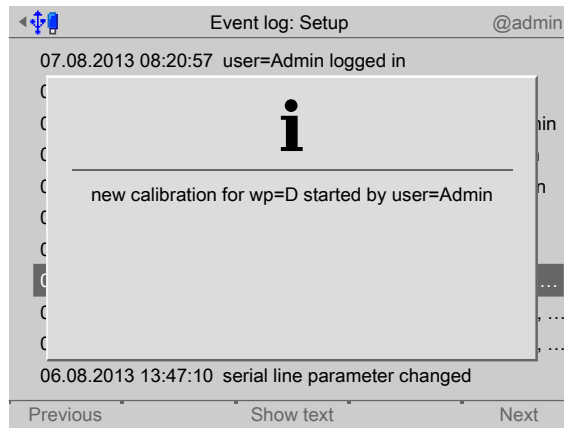

5. Press **EXIT** to return to the previous window.

5.10 Print configuration settings

In this menu item (under **System information**), the configuration settings can be printed.

Requirements:

- Print parameters have been entered; see Chapter [4.1.4](#)
- Printer is connected; see Chapter [4.1.4](#).

Note:

If no printer has been connected, the message "No printer configured" appears.

Accessible via **MENU** - [Operating] - [System information] - [Print configuration settings]

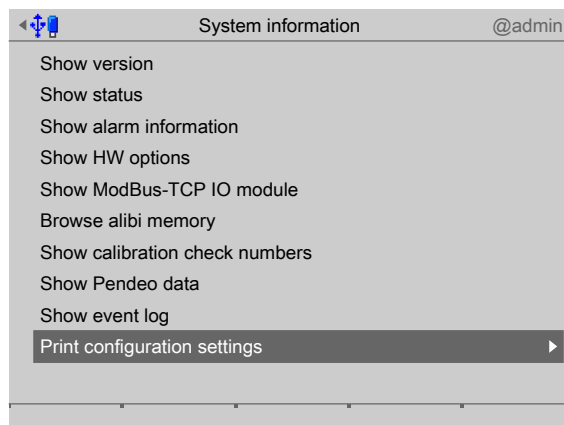

1. Select and confirm [Print configuration settings].
 - ▷ A prompt window appears.

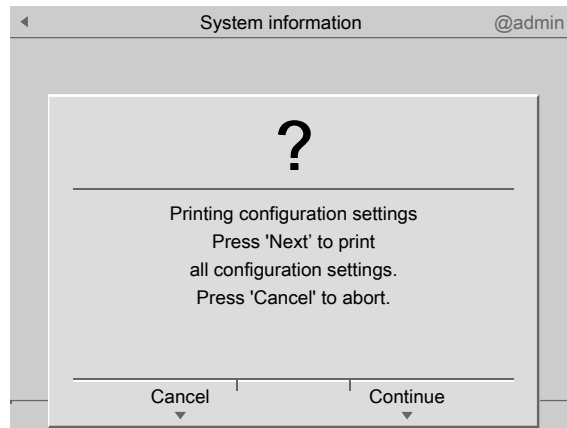

2. Press the [Continue] soft key.
 - ▷ The configuration is printed out; for an example, see Chapter [10.1](#).

6 System maintenance

NOTICE

Incorrect operation can cause data loss.

- ▶ Data transfer may only be carried out by authorized specialist personnel.

In the system maintenance menu (under **System menu**), the system maintenance parameters are configured.

- [Backup], see Chapter 6.1.
- [Restore], see Chapter 6.2.
- [Export], see Chapter 6.3.
- [Import], see Chapter 6.4.
- [Alibi memory maintenance], see Chapter 6.5.
- [SD card maintenance], see Chapter 6.6.
- [Create service report], see Chapter 6.7.
- [Shutdown & Power off] (switch off device), see Chapter 6.8.
- [Update software], see Chapter 6.9.
- [Factory reset], see Chapter 6.10.
- [Test hardware], see Chapter 6.11.

Accessible via **MENU** - [Operation]- [System maintenance] .

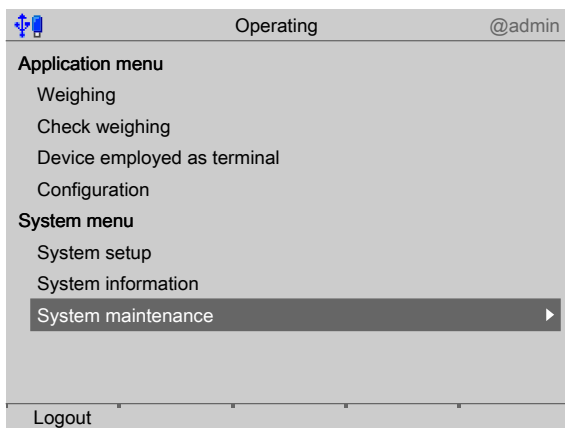

- ▶ Select and confirm [System maintenance].
 - ▷ The system maintenance menu is displayed.

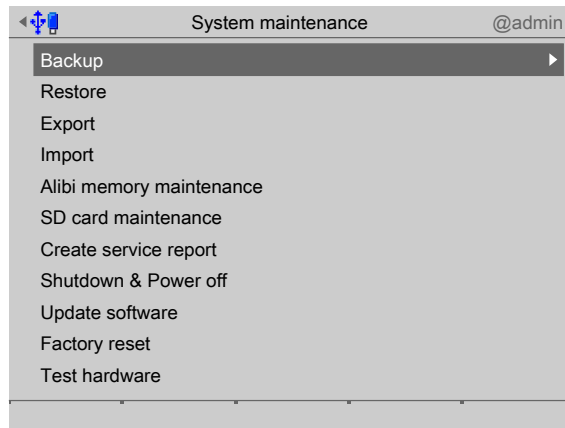

Note:

When user management is activated, the logged in user must have rights for the following:

- Complete system maintenance,
 - Importing (importing and restoring), and
 - Exporting (exporting and saving).
-

6.1 Backup

In this menu item (under **System maintenance**), the current configuration and/or database of the device is saved as a backup to connected storage media or in enabled directories.

- [SD card], see Chapter [6.1.1](#).
- [USB stick], see Chapter [6.1.2](#).
- Shared directory (under Network share connections), see Chapter [6.1.3](#).

A backup can be performed for the following reasons:

- The current data is needed on another device.
- The configuration data is to be archived centrally.
- The configuration and/or database might be deleted accidentally.
- The configuration might be changed inadvertently.

The saved data can be restored later.

The backup stores the records in a format that can only be restored via the [Restore] function.

Note:

If the **EXIT** button is pressed while the backup is being created, all created files are deleted.

Accessible via **MENU** - [Operating] - [System maintenance] - [Backup] .

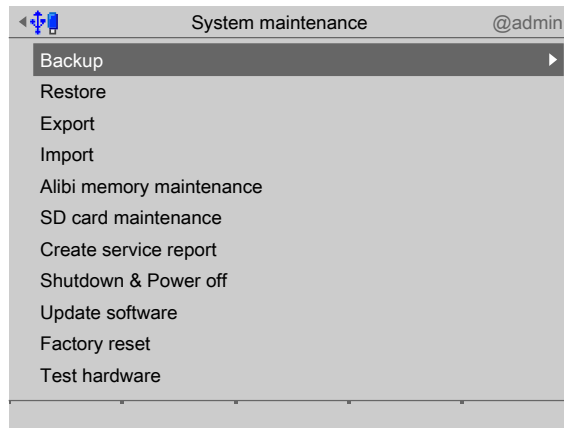

- ▶ Select and confirm [Backup].
- ▷ The window listing the available storage media is shown.

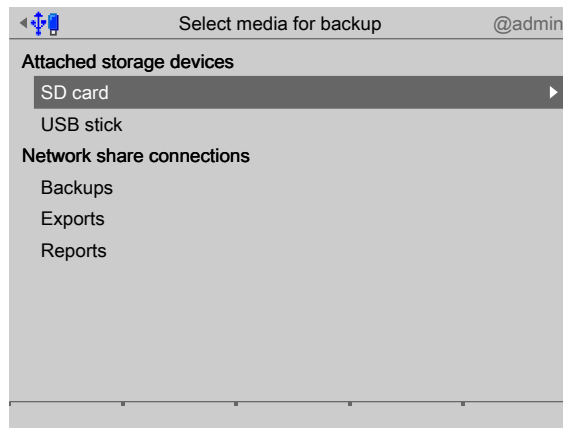

Note:

The connections with the shared directories are only shown if this has been configured in the menu [Operating]- [System setup]- [Network share connections] .

6.1.1 SD card

In this menu item (under **Backup**), a backup is saved on an internal SD card if it is required

- on this device or
- on a replacement device.

Accessible via **MENU** - [Operating] - [System maintenance] - [Backup] - [SD card] .

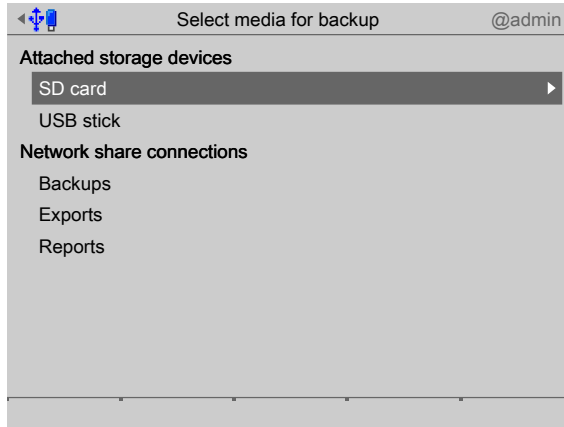

1. Select and confirm [SD card].

▷ A selection window opens.

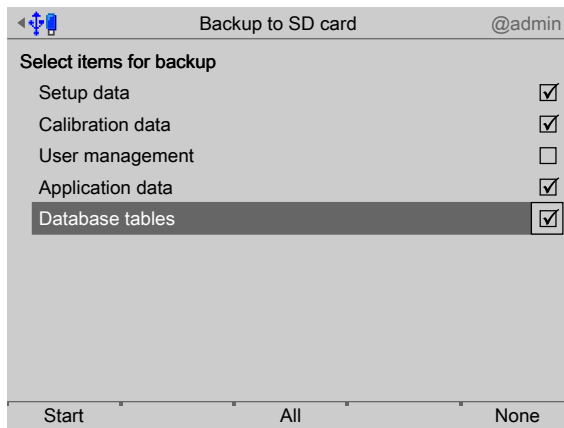

2. Check the appropriate box or press the [All] soft key to select all possible items.

Press the [None] soft key to deselect all selected items.

3. Press the [Start] soft key to start the process.

▷ An input window opens.

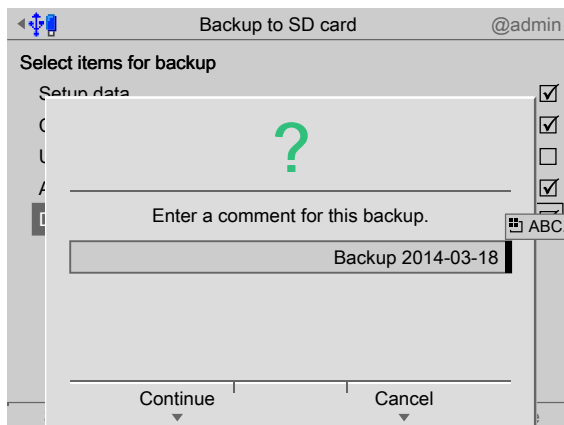

4. Enter a comment using the keyboard.

Note:

The saved data is stored on the SD card in the directory "backup":

/YYYYMMDDHHMMSS/

Where:

YYYYMMDDHHMMSS = time of save

5. Press the [Continue] soft key.
 - ▷ The progress windows for the individual items appear and then disappear in order. An information window is displayed when the process is complete.

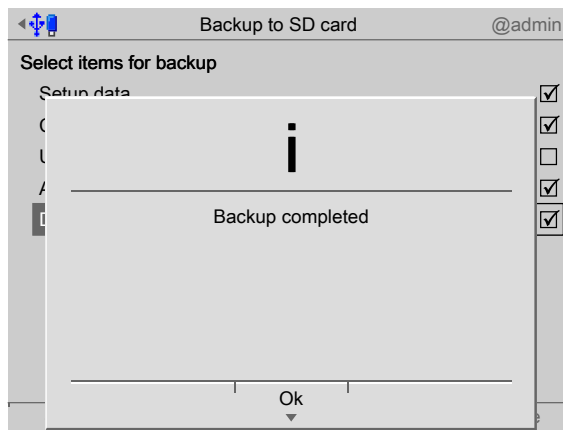

6. Press the [OK] soft key to return to the [System maintenance] menu.

6.1.2 USB stick

In this menu item (under **Backup**), a backup is saved on a connected USB stick if archiving on a central data carrier is required.

Accessible via **MENU** - [Operating] - [System maintenance]- [Backup]- [USB stick] .

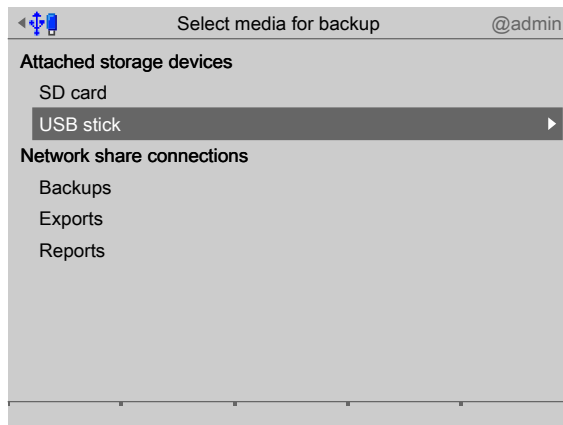

1. Select and confirm [USB stick].

Note:

If no USB stick is plugged in, a warning appears.

- Plug in a USB stick and wait until the symbol  appears in the info line.
- Press the [Retry] soft key.

▷ A selection window opens.

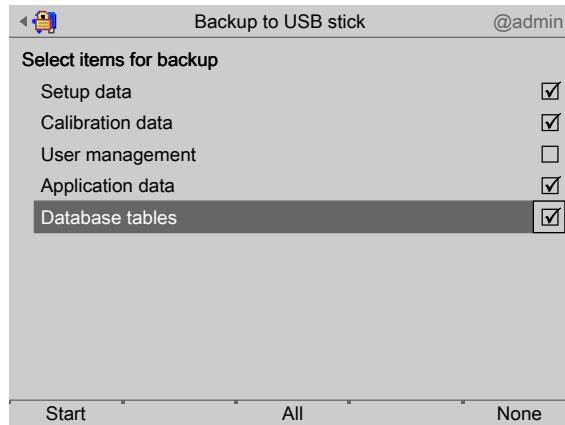

2. Check the appropriate box or press the [All] soft key to select all possible items. Press the [None] soft key to deselect all selected items.
3. Press the [Start] soft key to start the process.

▷ An input window opens.

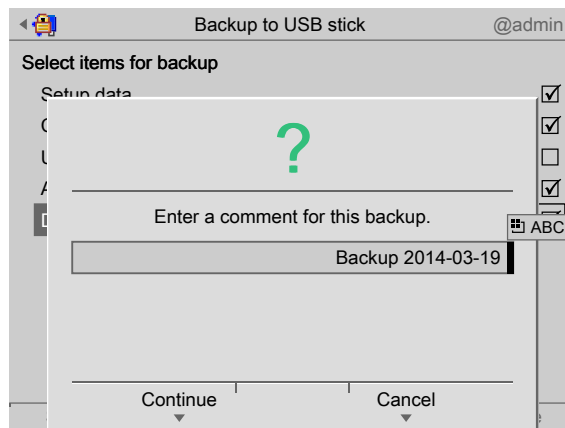

4. Enter a comment using the keyboard.

Note:

The saved data is stored on the USB stick in the directory "backup":

/pr5900/hostname/YYYYMMDDHHMMSS/

Where:

Hostname = device name from the network settings

YYYYMMDDHHMMSS = time of save

5. Press the [Continue] soft key.
 - ▷ The progress windows for the individual items appear and then disappear in order. An information window is displayed when the process is complete.

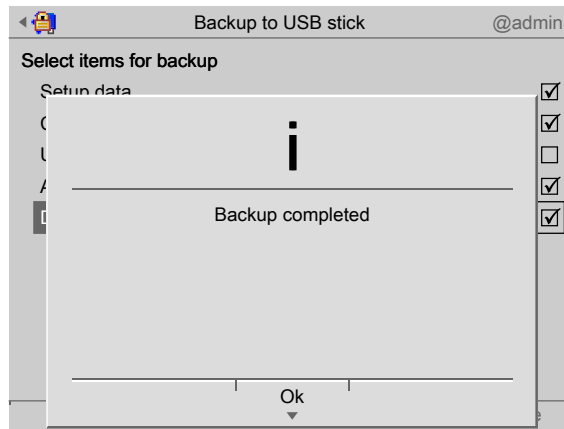

6. Press the [OK] soft key to return to the [System maintenance] menu.

6.1.3 Shared directory

In this menu item (under **Backup**), a backup is saved in a shared directory (under Network share connections) if archiving on a central data carrier is required.

Note:

The connections with the shared directories are only shown if this has been configured in the menu [Operating]- [System setup]- [Network share connections].

Accessible via **MENU** - [Operating] - [System maintenance]- [Backup] in this case, directory: [Backups].

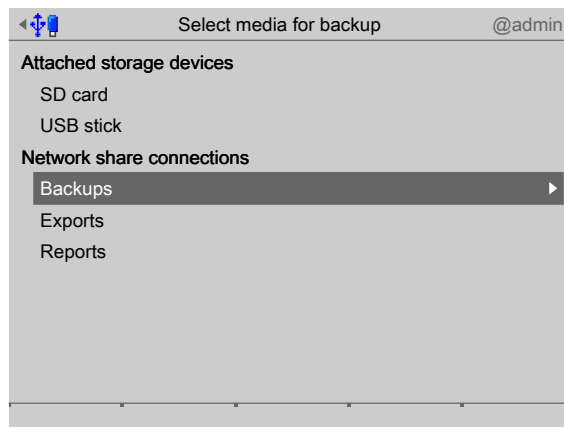

1. In this case: Select and confirm [Backups].
 - ▷ A selection window opens.

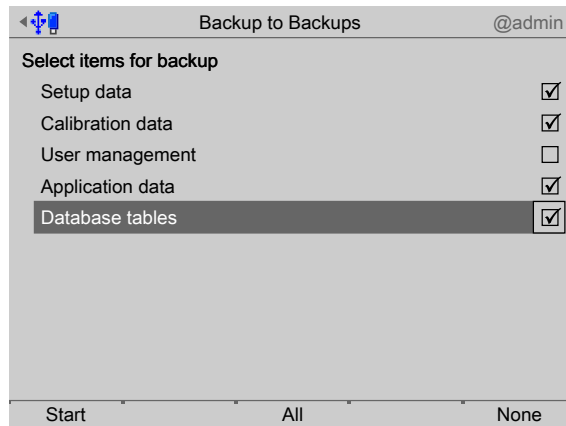

2. Check the appropriate box or press the [All] soft key to select all possible items. Press the [None] soft key to deselect all selected items.
3. Press the [Start] soft key to start the process.
 - ▷ An input window opens.

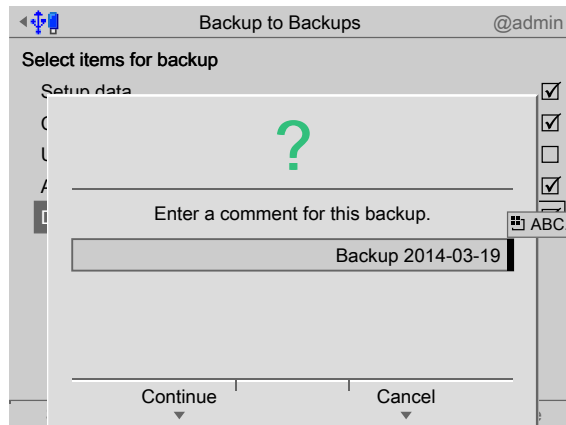

4. Enter a comment using the keyboard.

Note:

The saved data is stored on the shared directory in the directory "backup":

/pr5900/hostname/YYYYMMDDHHMMSS/

Where:

Hostname = device name from the network settings

YYYYMMDDHHMMSS = time of save

5. Press the [Continue] soft key.
 - ▷ The progress windows for the individual items appear and then disappear in order. An information window is displayed when the process is complete.

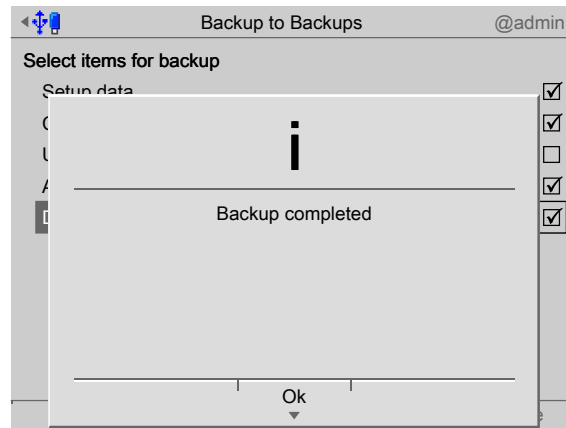

6. Press the [OK] soft key to return to the [System maintenance] menu.

6.2 Restore

In this menu item (under **System maintenance**), the data saved in a **backup** (see Chapter 6.1) is restored to the device.

A backup can be restored from:

- [SD card], see Chapter 6.2.1.
- [USB stick], see Chapter 6.2.2.
- Shared directory (Network share connection), see Chapter 6.2.3.

Note:

During the restoring process, all data selected on the device is overwritten with the data from the backup.

The network settings are **not** overwritten.

The following applies:

- Restoring the setup data will replace all settings and therefore delete all settings made after the backup.
- Restoring the calibration data will replace the current calibration and therefore delete all calibrations made after the backup.
- Restoring the user management data will overwrite all users and therefore delete all users created after the backup.
- Restoring the application data will overwrite all settings and therefore delete all settings made after the backup.
- Restoring the database will overwrite all tables and entries in the database.
- Licenses will not be overwritten if:
 - CAL switch 2 is closed or
 - [W&M mode] is selected and the parameter [Settings locked] is activated for at least one weighing point and
 - the board number in the restore file corresponds to the board number of the device.
- Licenses will not be overwritten if CAL switch 1 is closed or [W&M mode] is selected and the parameter [Settings locked] is activated for at least one weighing point.

Accessible via **MENU** – [Operating] - [System maintenance] - [Restore].

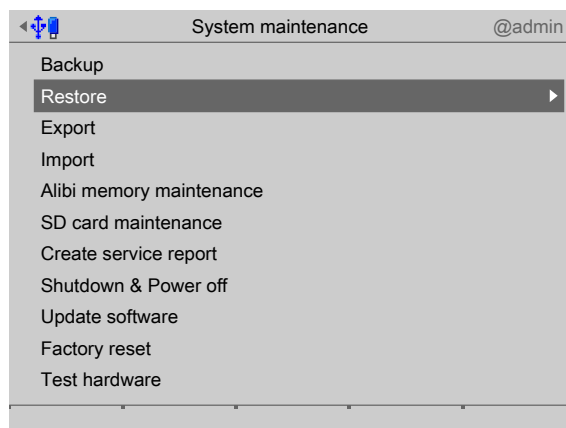

- ▶ Select and confirm [Restore].
 - ▷ The window listing the available storage media is shown.

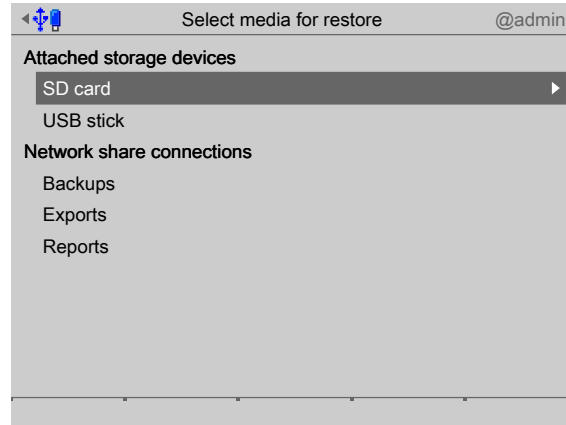
**Note:**

The connections with the shared directories are only shown if this has been configured in the menu [Operating]- [System setup]- [Network share connections] .

6.2.1 SD card

In this menu item (under **Restore**), a **backup** is restored from the internal SD card.
Accessible via **MENU** - [Operating] - [System maintenance]- [Restore]- [SD card] .

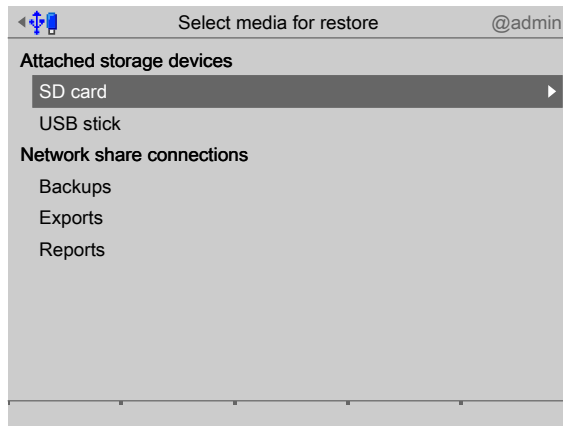

1. Select and confirm [SD card].
 ▷ A selection window opens.

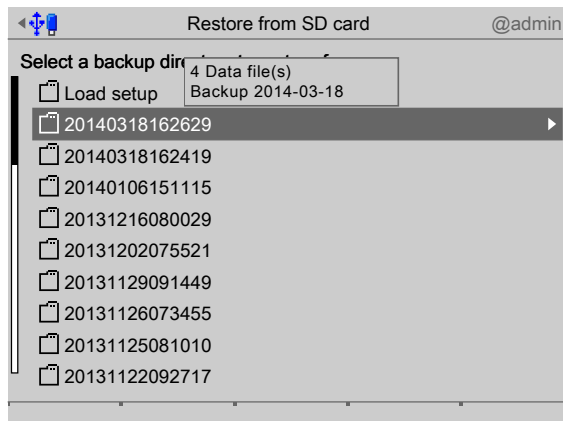

2. Select and confirm the desired folder.

▷ A selection window opens.

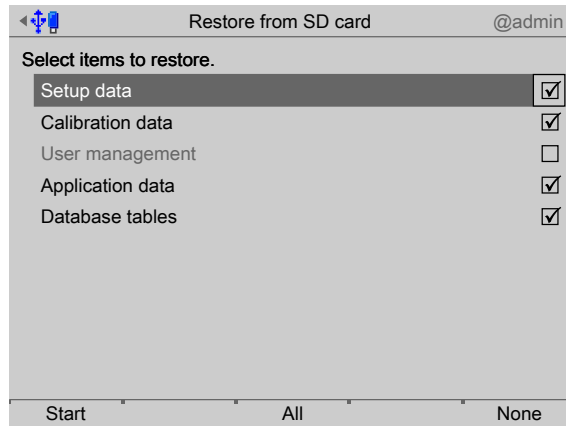

3. Check the appropriate box or press the [All] soft key to select all possible items.

Press the [None] soft key to deselect all selected items.

4. Press the [Start] soft key to start the process.

▷ If the database tables on the storage medium are not designed for the application currently on the device, a warning message is displayed.

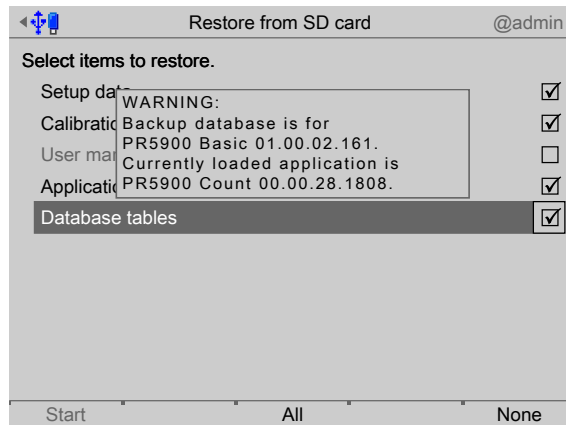

5. If necessary, choose a different backup directory.

▷ A prompt window appears.

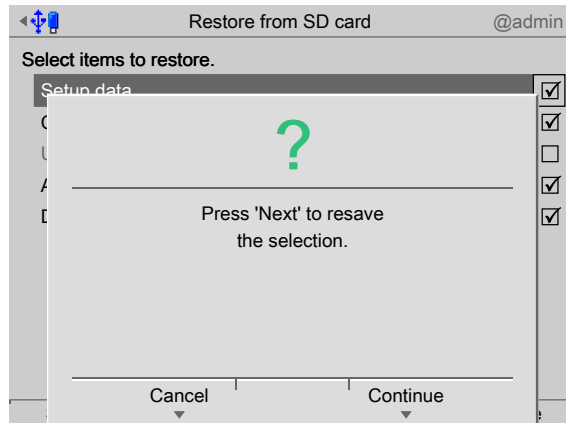

6. Press the [Continue] soft key.

- ▷ The progress windows for the individual items appear and then disappear in order. An information window is displayed when the process is complete.

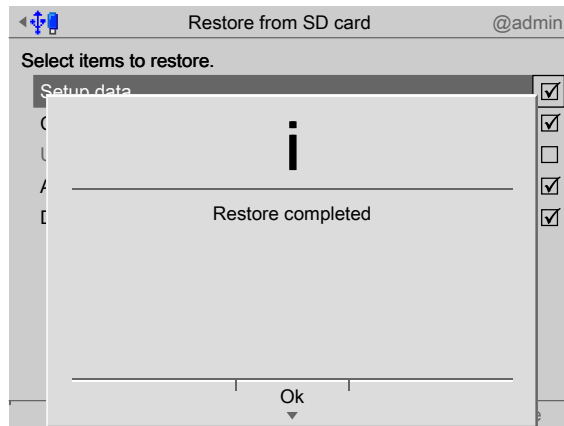

7. Press the [OK] soft key to return to the [System maintenance] menu.

6.2.2 USB stick

In this menu item (under **Restore**), a **backup** is restored from a connected USB stick. Accessible via **MENU** - [Operating] - [System maintenance]- [Restore]- [USB stick] .

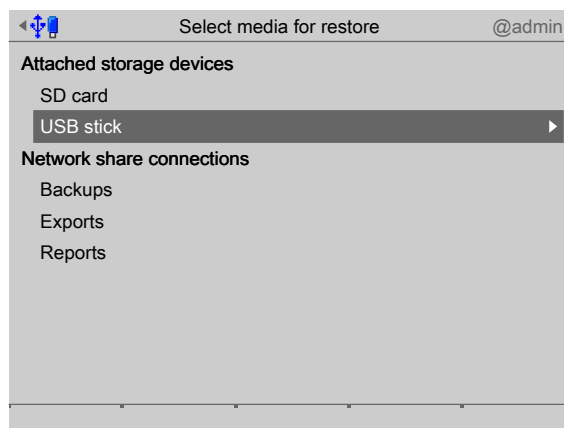

1. Select and confirm [USB stick].

Note:

If no USB stick is plugged in, a warning appears.

- Plug in a USB stick and wait until the symbol  appears in the info line.
 - Press the [Retry] soft key.
-

- ▷ The content of the USB stick is displayed.

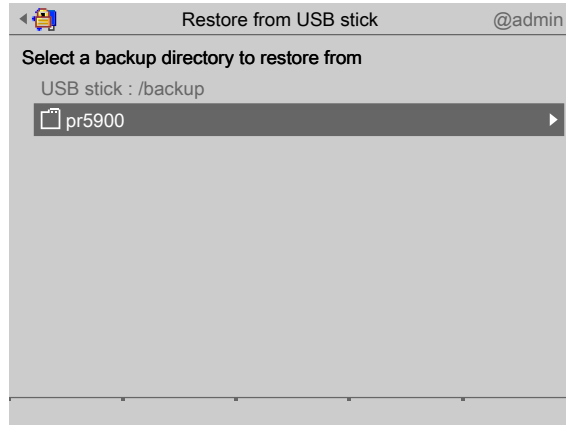

2. Select and confirm the desired folder.

▷ A selection window opens.

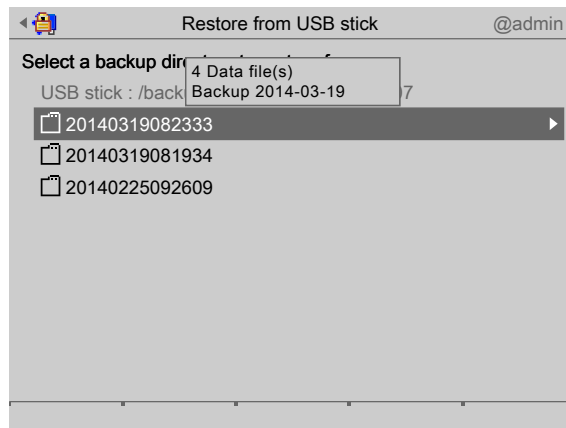

3. Select and confirm the desired folder.

▷ A selection window opens.

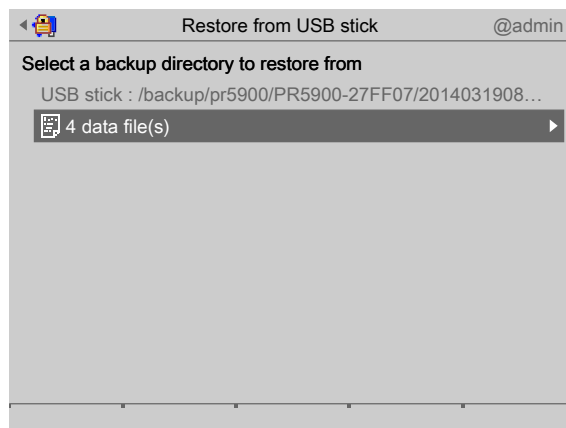

4. Select and confirm the desired folder.

▷ A selection window opens.

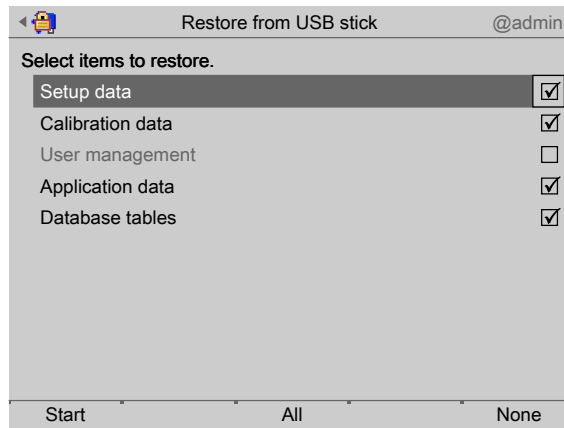

5. Check the appropriate box or press the [All] soft key to select all possible items. Press the [None] soft key to deselect all selected items.
6. Press the [Start] soft key to start the process.

Note:

If the database tables on the storage medium are not designed for the application currently on the device, a warning message is displayed, see Chapter [6.2.1](#).

If necessary, choose a different backup directory.

- ▷ A prompt window appears.

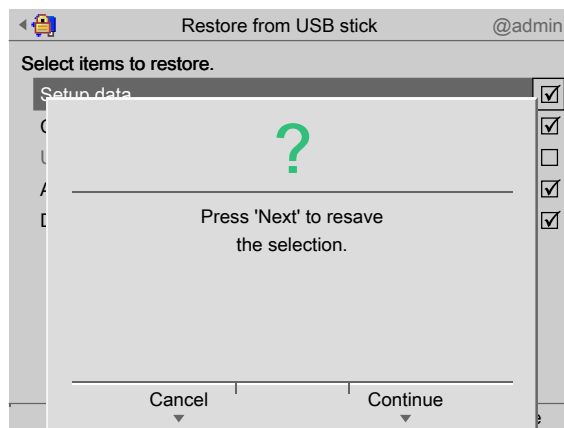

7. Press the [Continue] soft key.
 - ▷ The progress windows for the individual items appear and then disappear in order. An information window is displayed when the process is complete.

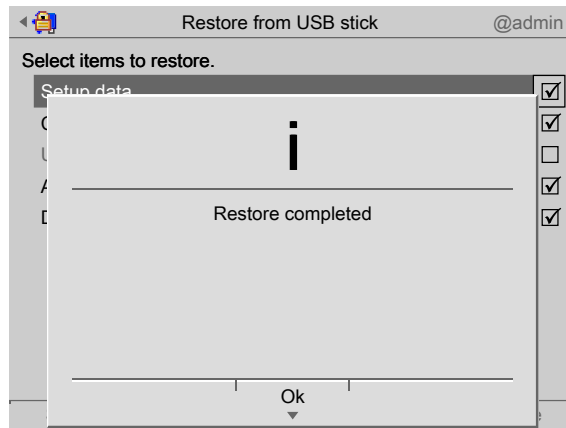

8. Press the [OK] soft key to return to the [System maintenance] menu.

6.2.3 Shared directory

In this menu item (under **Restore**), a **backup** is restored from a shared directory (under Network share connections).

Note:

The connections with the shared directories are only shown if this has been configured in the menu [Operating]- [System setup]- [Network share connections].

Accessible via **MENU** - [Operating] - [System maintenance]- [Restore] in this case, directory: [Backups].

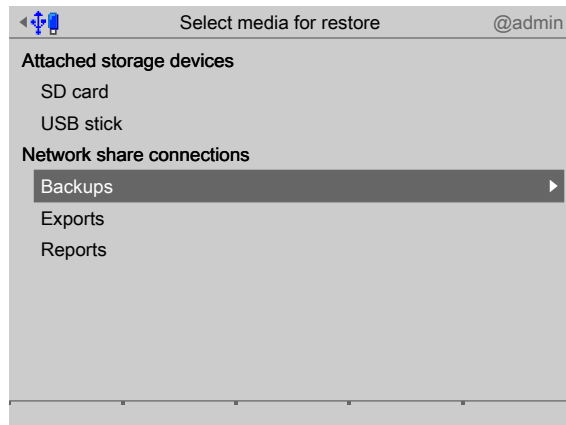

1. In this case: Select and confirm [Backups].
 - ▷ A selection window opens.

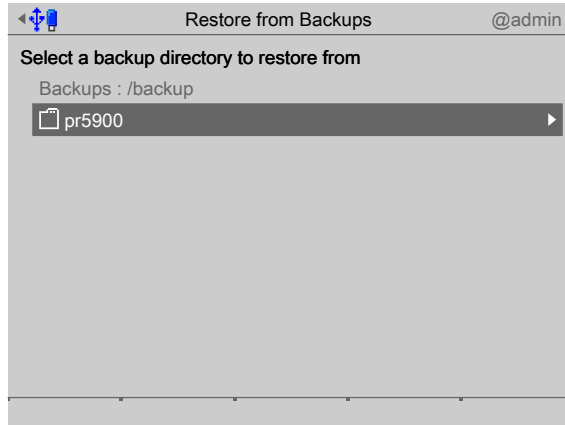

2. Select and confirm the desired folder.

▷ A selection window opens.

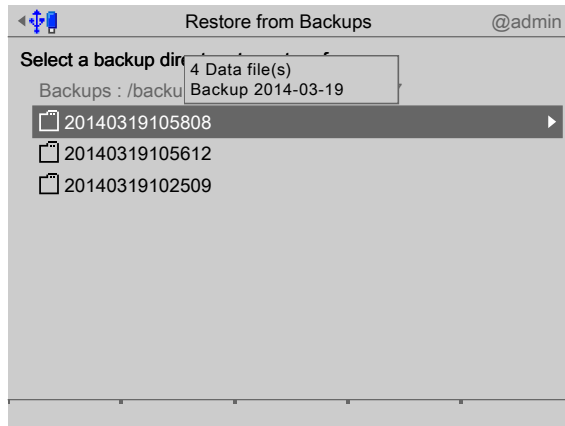

3. Select and confirm the desired folder.

▷ A selection window opens.

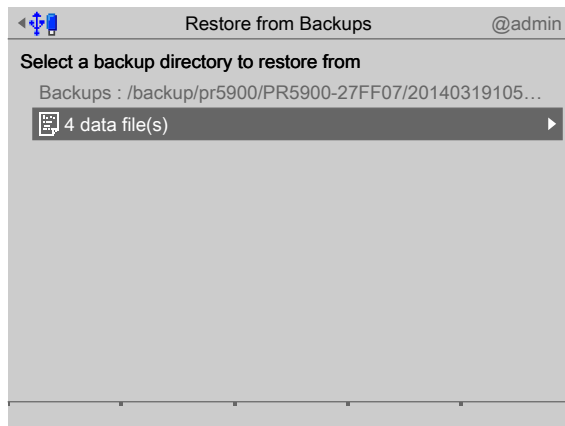

4. Select and confirm the desired folder.

▷ A selection window opens.

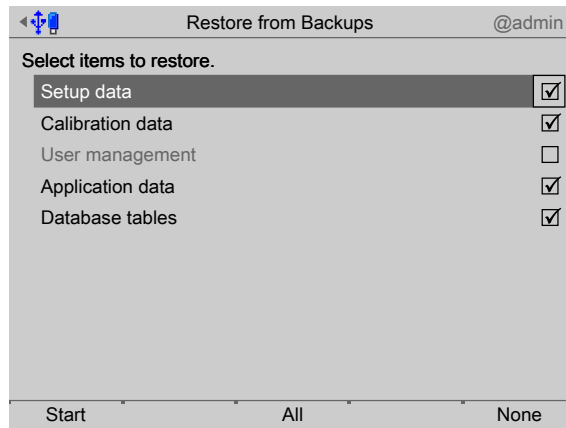

5. Check the appropriate box or press the [All] soft key to select all possible items. Press the [None] soft key to deselect all selected items.
6. Press the [Start] soft key to start the process.

Note:

If the database tables on the storage medium are not designed for the application currently on the device, a warning message is displayed, see Chapter [6.2.1](#).

If necessary, choose a different backup directory.

- ▷ A prompt window appears.

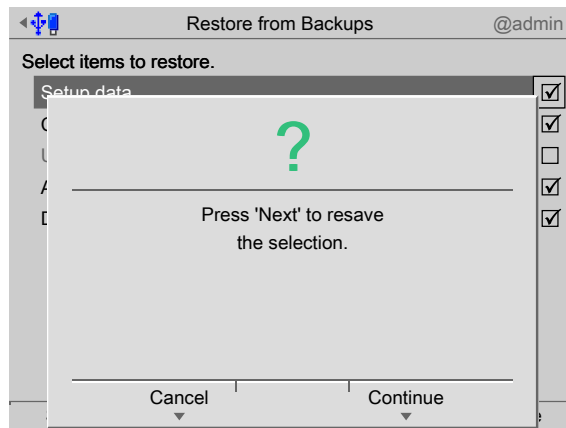

7. Press the [Continue] soft key.
 - ▷ The progress windows for the individual items appear and then disappear in order. An information window is displayed when the process is complete.

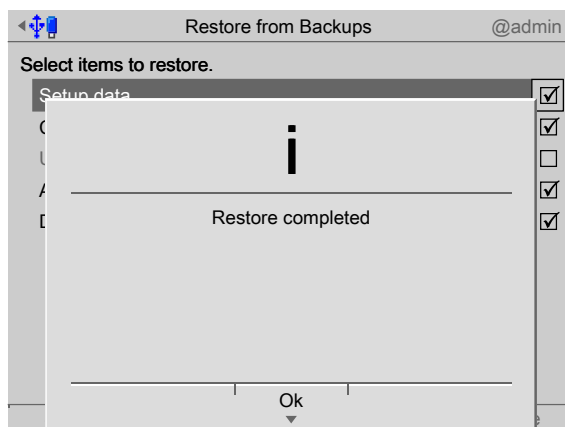

8. Press the [OK] soft key to return to the [System maintenance] menu.

6.3 Export

In this menu item (under **System maintenance**), the data saved on the device is exported to a storage medium (e.g. for processing database tables).

- [USB stick], see Chapter [6.3.1](#).
- Shared directory (Network share connection), see Chapter [6.3.2](#).

Note:

Only data saved on the device using the [Save] soft key is exported.

Exported data is saved in XML format. These files can then be opened in an editor (e.g. Windows Notepad) for closer inspection, or to apply an import filter for XML processing software.

Examples:

- Exporting all settings and compiling the host names assigned for the network settings to generate a list of device names.
- Exporting all calibration data to generate a report for all weighing points in the system.
- Exporting the database to generate statistics from the REPORT table for the batching software.

Note:

The exported data is stored on the storage medium in the following directory:

/pr5900/hostname/YYYYMMDDHHMMSS/

Where:

Hostname = device name from the network settings

YYYYMMDDHHMMSS = time of the export

Accessible via **MENU** - [Operating] - [System maintenance] - [Export] .

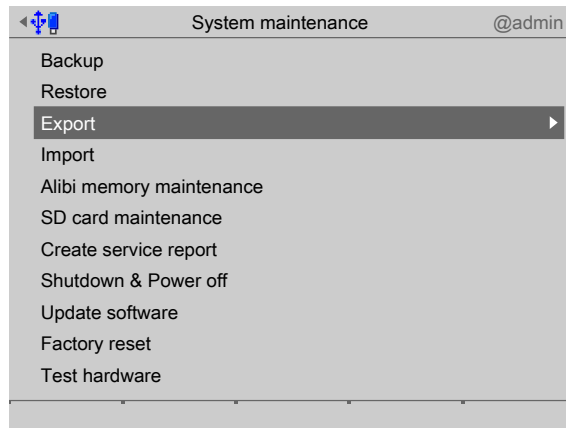

▶ Select and confirm [Export].

▷ The window listing the available storage media is shown.

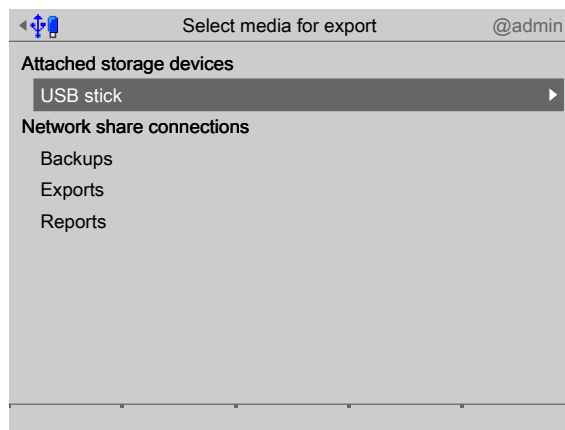

Note:

The connections with the shared directories are only shown if this has been configured in the menu [Operating]- [System setup]- [Network share connections] .

6.3.1 USB stick

In this menu item (under **Export**), the data saved on the device is exported to a connected USB stick.

Accessible via **MENU** - [Operating] - [System maintenance] - [Export] - [USB stick] .

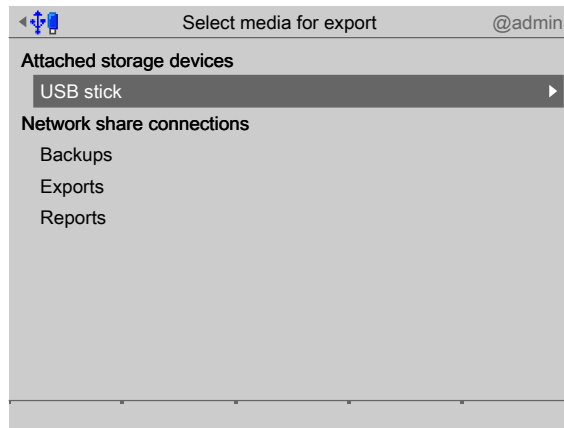

1. Select and confirm [USB stick].

Note:

If no USB stick is plugged in, a warning appears.

- Plug in a USB stick and wait until the symbol  appears in the info line.
 - Press the [Retry] soft key.
-

- ▷ A selection window opens.

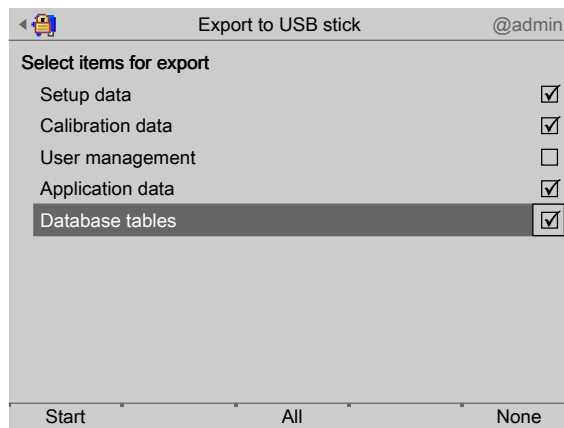

2. Check the appropriate box or press the [All] soft key to select all possible items.
Press the [None] soft key to deselect all selected items.
3. Press the [Start] soft key to start the process.
 - ▷ An input window opens.



4. Enter a comment using the keyboard.
5. Press the [Continue] soft key.
 - ▷ The progress windows for the individual items appear and then disappear in order. An information window is displayed when the process is complete.

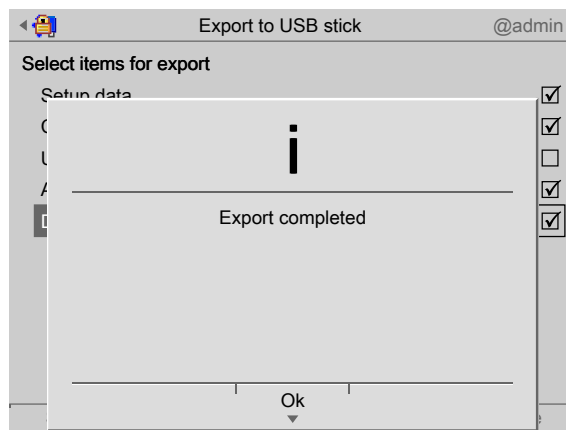

6. Press the [OK] soft key to return to the [System maintenance] menu.

6.3.2 Shared directory

In this menu item (under **Export**), the data saved on the device is exported to a shared directory (under Network share connections).

Note:

The connections with the shared directories are only shown if this has been configured in the menu [Operating]- [System setup]- [Network share connections].

Accessible via **MENU** - [Operating] - [System maintenance] - [Export] in this case, directory: [Exports].

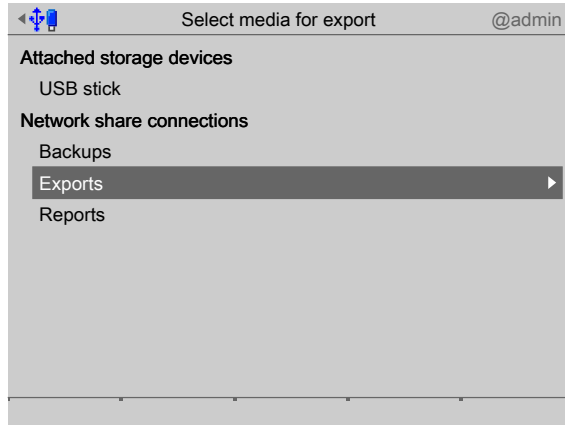

1. In this case: Select and confirm [Exports].

▷ A selection window opens.

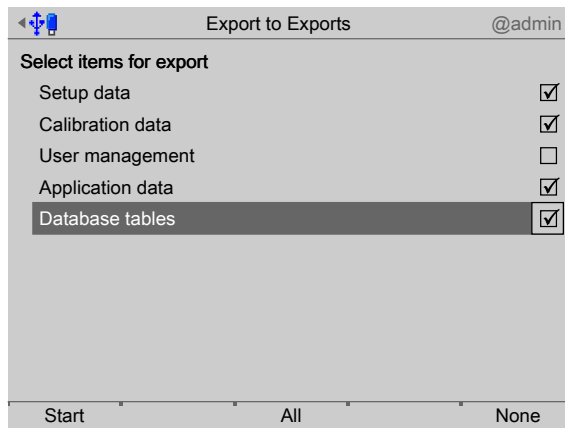

2. Check the appropriate box or press the [All] soft key to select all possible items. Press the [None] soft key to deselect all selected items.

3. Press the [Start] soft key to start the process.

▷ An input window opens.



4. Enter a comment using the keyboard.

5. Press the [Continue] soft key.

▷ The progress windows for the individual items appear and then disappear in order. An information window is displayed when the process is complete.



6. Press the [OK] soft key to return to the [System maintenance] menu.

6.4 Import

In this menu item (under **System maintenance**), exported data (or e.g. database tables generated by a PC) is imported from a storage medium to a device.

- USB stick, see Chapter [6.4.1](#).
- Shared directory (Network share connection), see Chapter [6.4.2](#).

Data for the import must be in XML format. The format must be the same as the one used for the export. The data can also be created with a known format manually (e.g. with Windows Notepad) or via a software export.

Examples

- Creating operating parameters to make the parameters for all devices available in the system.
- Providing data for user management to ensure the same access rights for all devices.
- Providing a new tare table every day for the BASIC application.

Note:

During the importing process, only data present in the record being imported will be overwritten.

The following applies:

- Importing the setup data will only replace the settings present in the record. For example, if the record only contains operating parameters, the other settings will remain unchanged.
- Importing the calibration data will only replace the calibration values present in the record.
- Importing the user management data will only replace the settings present in the record. For example, if the record only contains new users, the existing users will remain unchanged.
- Importing the application data will only replace the settings present in the record. For example, if the record only contains print parameters, the other settings will remain unchanged.
- Importing the database tables will only replace the tables present in the record. If the record contains the tare table only, the text table will remain unchanged in the device; the tare table will be overwritten completely however.

Accessible via **MENU** - [Operating] - [System maintenance]- [Import] .

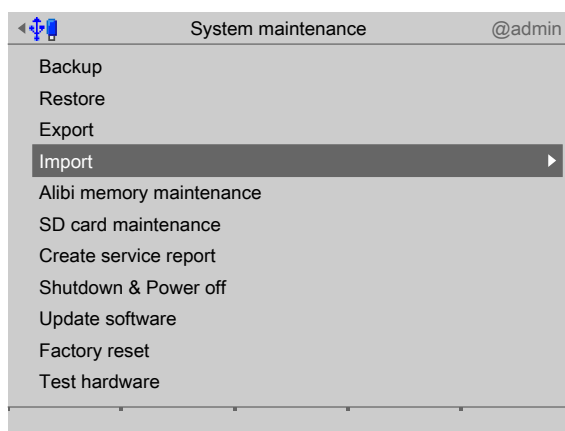

- ▶ Select and confirm [Import].
 - ▷ The window listing the available storage media is shown.

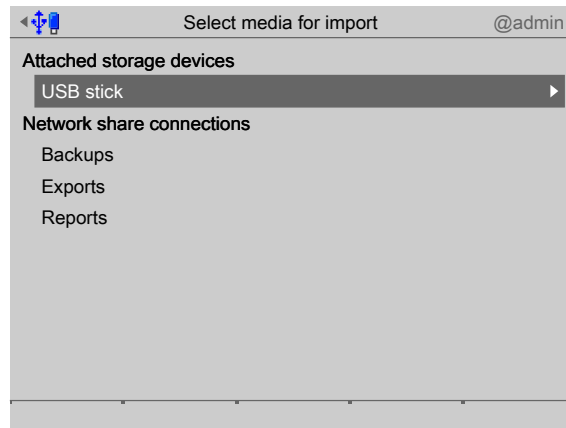

Note:

The connections with the shared directories are only shown if this has been configured in the menu [Operating]- [System setup]- [Network share connections] .

6.4.1 USB stick

In this menu item (under **Import**), data is imported from a connected USB stick.

Accessible via **MENU** - [Operating] - [System maintenance]- [Import]- [USB stick] .

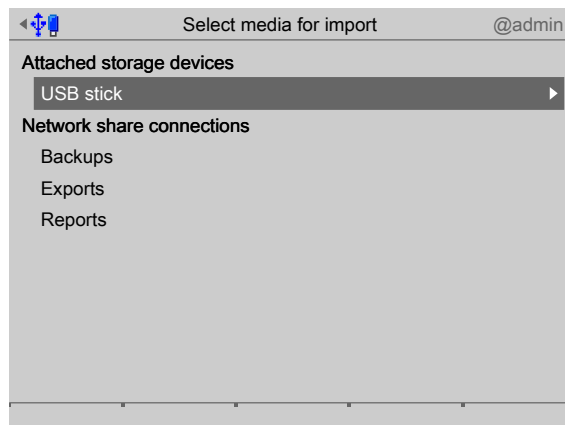

1. Select and confirm [USB stick].

Note:

If no USB stick is plugged in, a warning appears.

- Plug in a USB stick and wait until the symbol  appears in the info line.
 - Press the [Retry] soft key.
-

- ▷ A selection window opens.

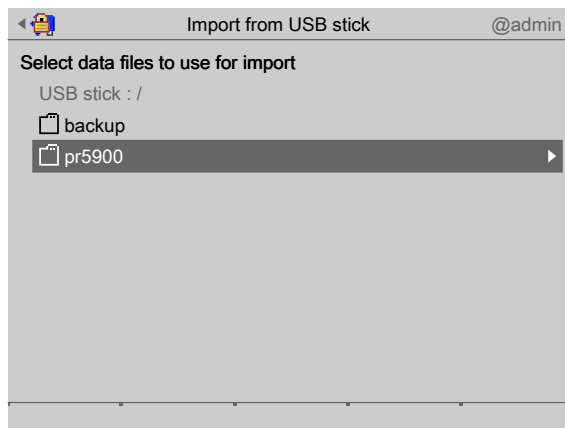

2. Select and confirm the desired folder.

▷ A selection window opens.

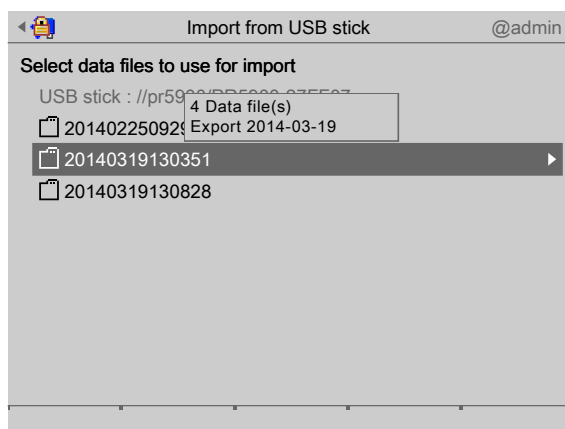

3. Select and confirm the desired folder.

▷ A selection window opens.



4. Select and confirm the desired folder.

▷ A selection window opens.

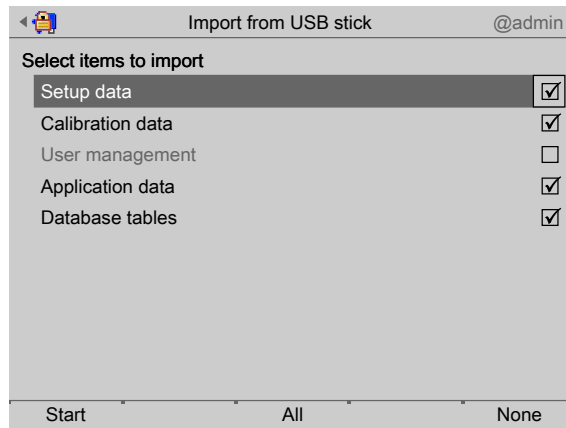

5. Check the appropriate box or press the [All] soft key to select all possible items. Press the [None] soft key to deselect all selected items.
6. Press the [Start] soft key to start the process.

Note:

If the database tables on the storage medium are not designed for the application currently on the device, a warning message is displayed, see Chapter [6.2.1](#).

If necessary, choose a different backup directory.

- ▷ A prompt window appears.



7. Press the [Continue] soft key.
 - ▷ The progress windows for the individual items appear and then disappear in order. An information window is displayed when the process is complete.

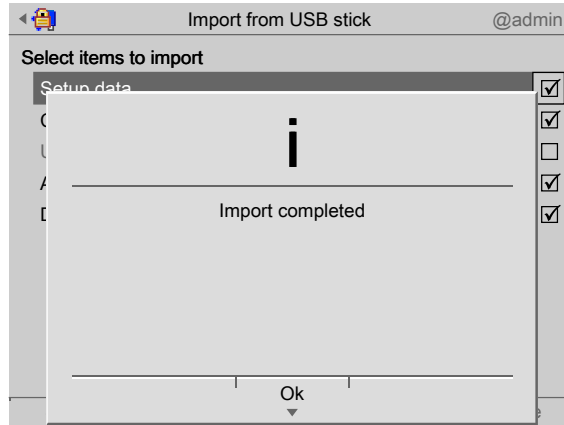

8. Press the [OK] soft key to return to the [System maintenance] menu.

6.4.2 Shared directory

In this menu item (under **Import**), data is imported from a shared directory (under Network share connections).

Note:

The connections with the shared directories are only shown if this has been configured in the menu [Operating]- [System setup]- [Network share connections].

Accessible via **MENU** - [Operating]- [System maintenance]- [Import] in this case, directory: [Exports].

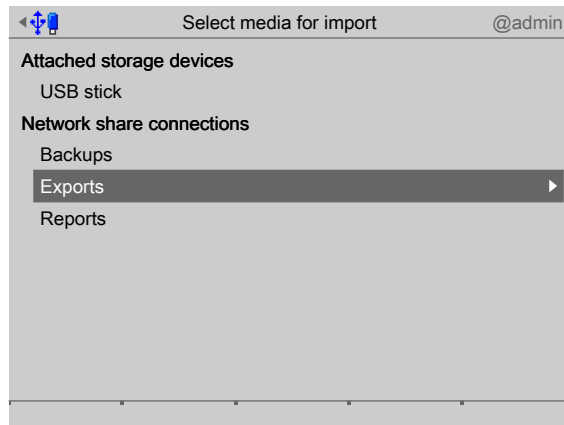

1. In this case: Select and confirm [Exports].
 - ▷ A selection window opens.

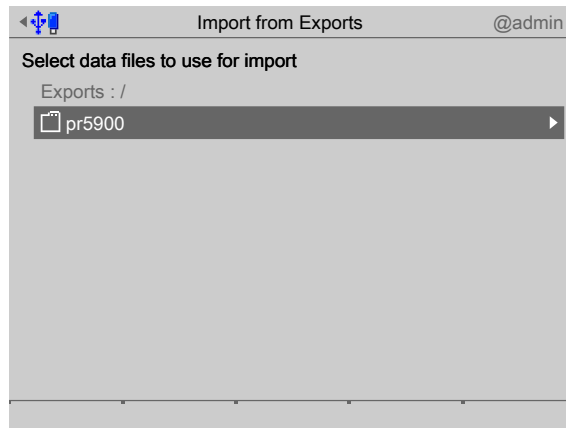

2. Select and confirm the desired folder.

▷ A selection window opens.

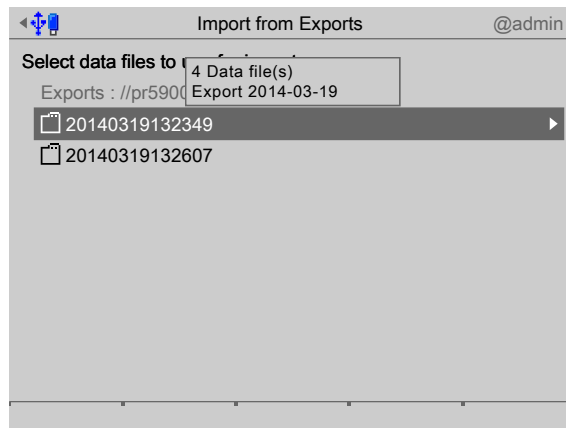

3. Select and confirm the desired folder.

▷ A selection window opens.

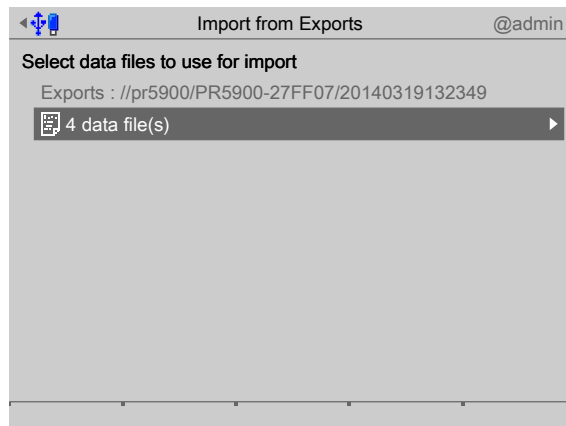

4. Select and confirm the desired folder.

▷ A selection window opens.

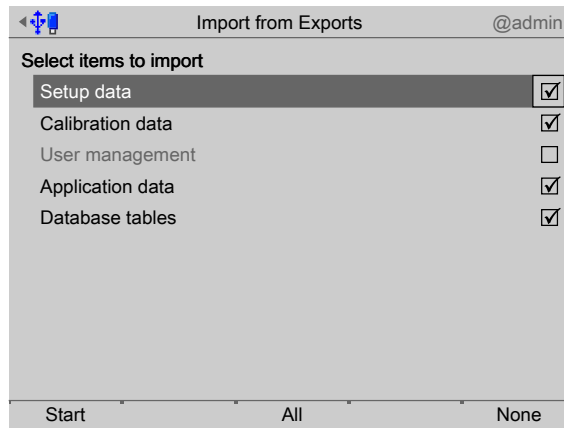

5. Check the appropriate box or press the [All] soft key to select all possible items. Press the [None] soft key to deselect all selected items.
6. Press the [Start] soft key to start the process.

Note:

If the database tables on the storage medium are not designed for the application currently on the device, a warning message is displayed, see Chapter [6.2.1](#).

If necessary, choose a different backup directory.

- ▷ A prompt window appears.



7. Press the [Continue] soft key.
 - ▷ The progress windows for the individual items appear and then disappear in order. An information window is displayed when the process is complete.

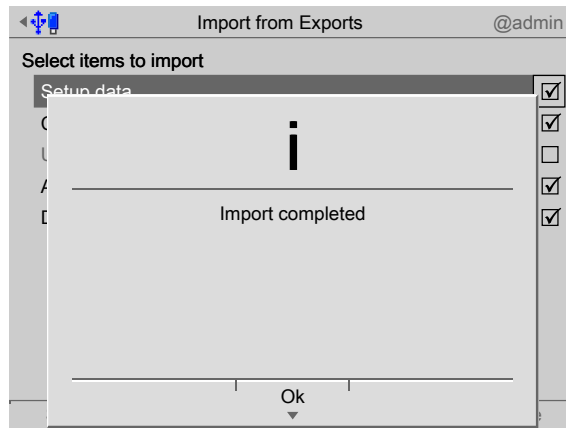

8. Press the [OK] soft key to return to the [System maintenance] menu.

6.5 Alibi memory maintenance

In this menu item (under **System maintenance**), records are exported to a storage medium in XML format and deleted or printed and deleted.

- [Export selection of records], see Chapter [6.5.1](#).
- [Export + tidy up selection of records] (delete), see Chapter [6.5.2](#).
- [Print selection of records], see Chapter [6.5.3](#).
- [Print + tidy up selection of records] (delete), see Chapter [6.5.4](#).

Accessible via **MENU** - [Operating]- [System maintenance]- [Alibi memory maintenance] .

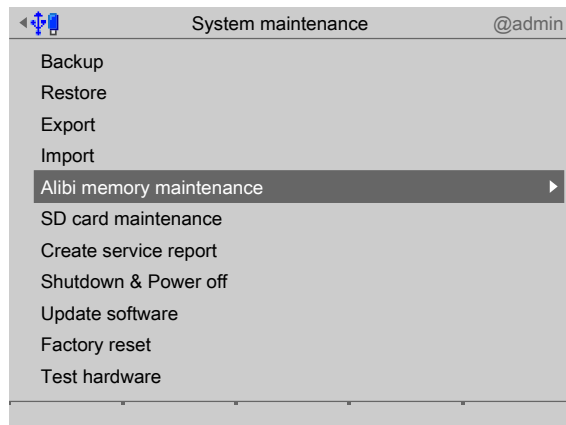

- ▶ Select and confirm [Alibi memory maintenance].
 - ▷ The Alibi memory maintenance window opens.

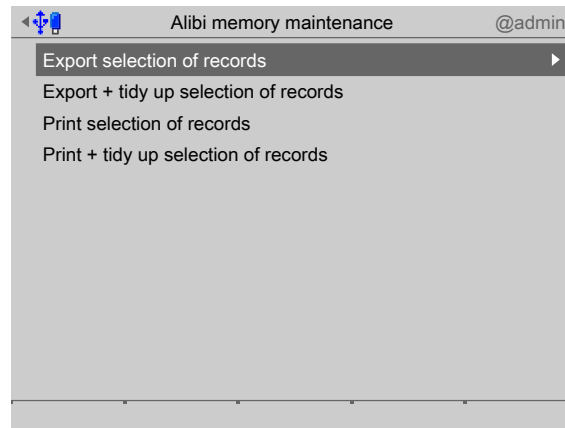

6.5.1 Export selection of records

In this menu item (under **Alibi memory maintenance**), a selection of records is exported from the Alibi memory to a storage medium.

Accessible via **MENU** - [Operating] - [System maintenance] - [Alibi memory maintenance] - [Export selection of records] .

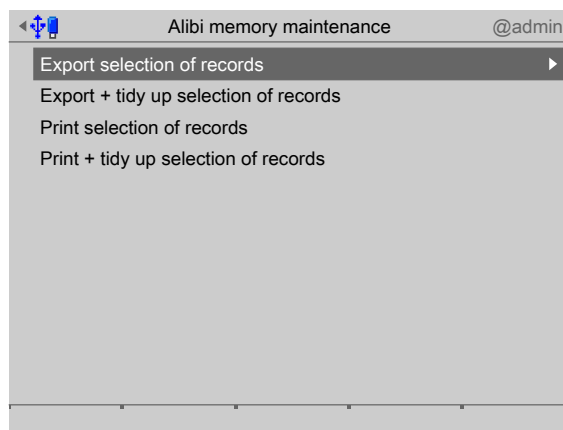

1. Select and confirm [Export selection of records].
 ▷ A window with the possible export range opens.

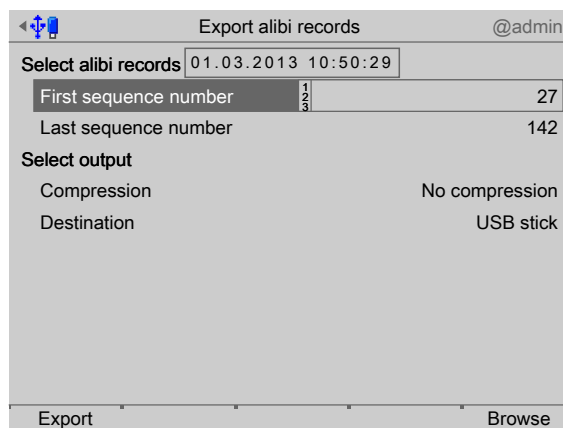

2. Press the [Browse] soft key to search for the first record of the range.
 ▷ A selection window opens.

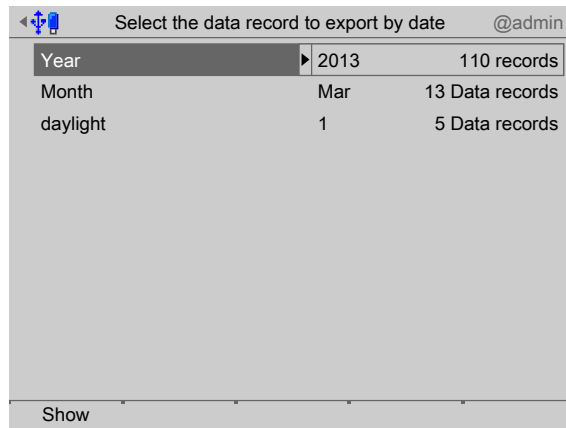

3. Select and confirm the desired record.

▷ A selection window opens.

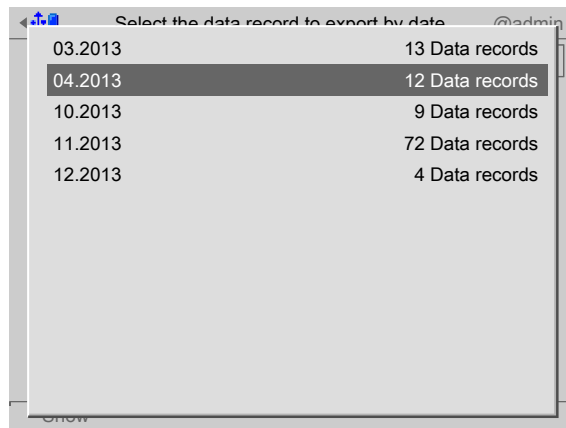

4. Select and confirm the desired record.

5. Press the [Show] soft key.

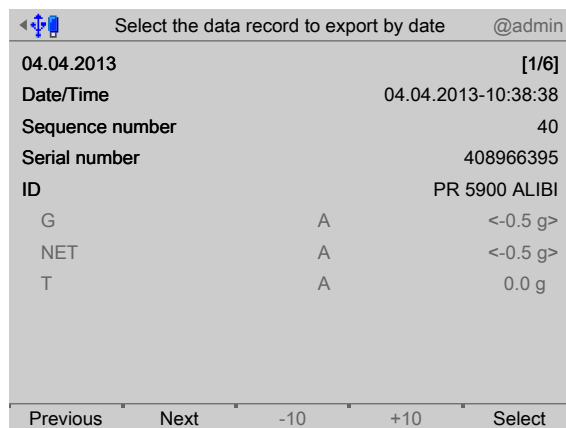

6. Press the [Previous]/[Next] soft key to display the desired record.

7. Press the [Select] soft key to confirm the first record of the range.

▷ Another window opens that displays the sequence number (here: 40) of the selected record under [First sequence number].

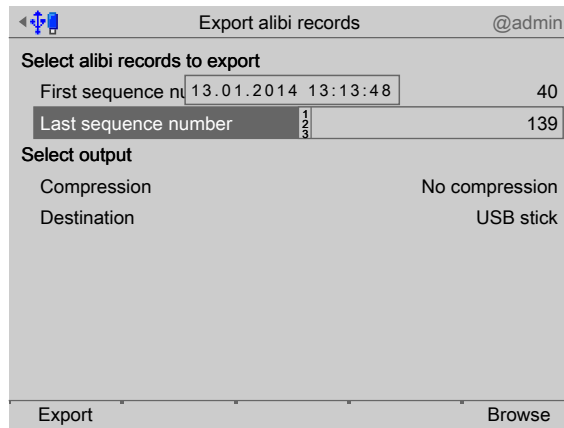

8. Define the last sequence number in accordance with the first sequence number.
9. Select and confirm the desired output parameters.

[Compression]

Selection: [No compression], best speed (reduced size with factor ~10, takes ~10% longer), best compression (reduced size with factor ~20, takes ~70% longer)

[Destination]

Selection: USB stick, shared directory (configuration in menu [Operating]- [System setup]- [Network share connections])

10. Press the [Export] soft key to start the export.

Note:

If no USB stick is plugged in, a warning appears.

- Plug in a USB stick and wait until the symbol  appears in the info line.
 - Press the [Retry] soft key.
-

- ▷ A prompt window appears.



11. Press the [Continue] soft key.

An XML file is saved on the USB stick.

- ▷ A progress window is shown during the save process. An information window is displayed when the process is complete.



12. Press the [OK] soft key to return to the [Alibi memory maintenance] menu.

Note:

Save to USB stick

The exported data is stored in an XML file on the USB stick in the following directory:

/export/hostname/alibi

where hostname = device name from the network settings

The file name is made up of the date, time, and sequence number range in square brackets and the file extension, e.g.: 2014032014332317 [27-139].xml.

Save to a shared directory

The exported data is stored in an XML file in a shared directory.

The file name is made up of the date, time, and sequence number range in square brackets and the file extension, e.g.: 2014032014332317 [27-139].xml.

6.5.2 Export + tidy up selection of records

In this menu item (under **Alibi memory maintenance**), a selection of records is exported from the Alibi memory to a storage medium and then deleted from the device.

Accessible via **MENU** - [Operating] - [System maintenance]- [Alibi memory maintenance]- [Export + tidy up selection of records] .

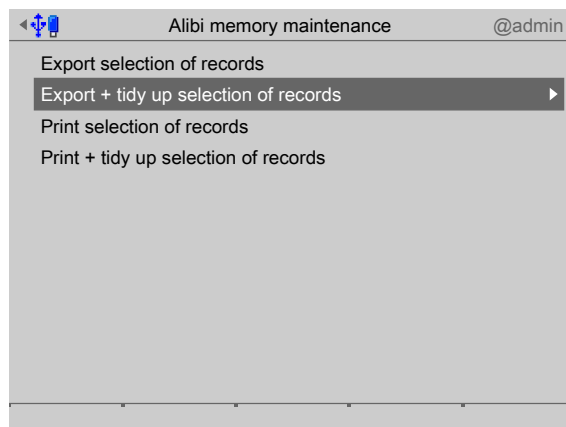

1. Select and confirm [Export + tidy up selection of records].

- ▷ A window with the possible export range opens.

The first record of the range is selected automatically and cannot be changed.

2. Select [Last sequence number] and press the [Browse] soft key to search for the last record of the range.

- ▷ A selection window opens.

3. Select and confirm the desired record.

- ▷ A selection window opens.

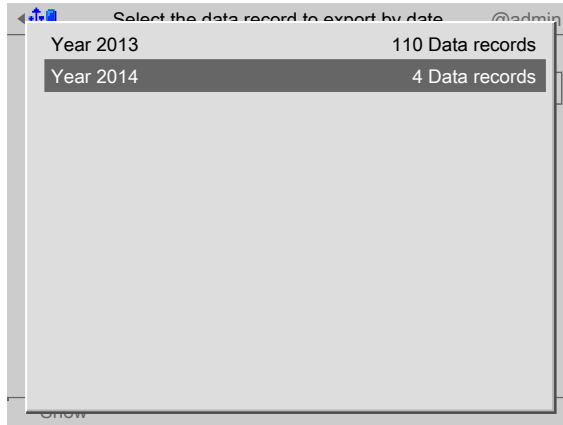

4. Select and confirm the desired record.
5. Press the [Show] soft key.

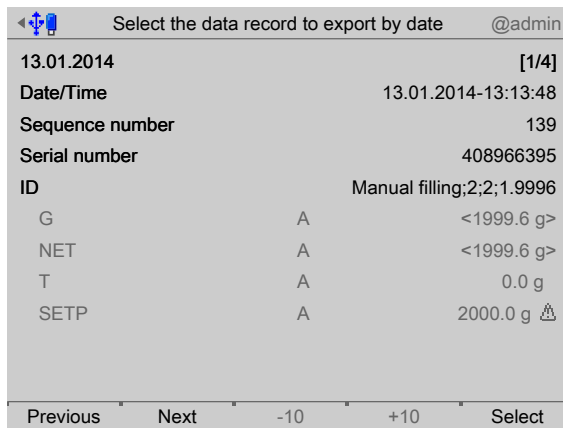

6. Press the [Previous]/[Next] soft key to display the desired record.
7. Press the [Select] soft key to confirm the last record of the range.
 - ▷ Another window opens that displays the sequence number (here: 139) of the selected record under [Last sequence number].

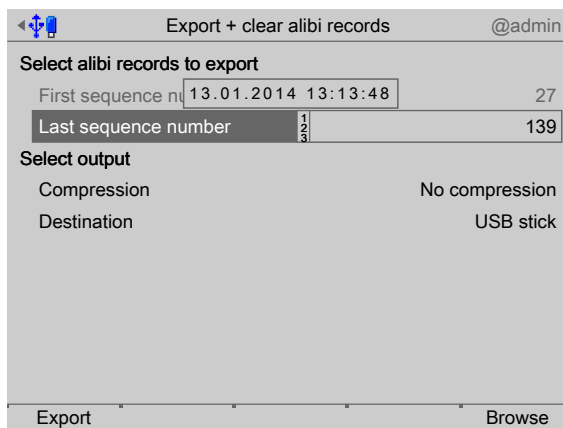

8. Select and confirm the desired output parameters.

[Compression]

Selection: [No compression], best speed (reduced size with factor ~10, takes ~10% longer), best compression (reduced size with factor ~20, takes ~70% longer)

[Destination]

Selection: USB stick, shared directory (configuration in menu [Operating]- [System setup]- [Network share connections])

9. Press the [Export] soft key to start the export.

Note:

If no USB stick is plugged in, a warning appears.

- Plug in a USB stick and wait until the symbol  appears in the info line.
- Press the [Retry] soft key.

- ▷ A prompt window appears.



10. Press the [Continue] soft key.

An XML file is saved on the USB stick.

- ▷ A progress window is shown during the save process. A prompt window appears when the process is complete.

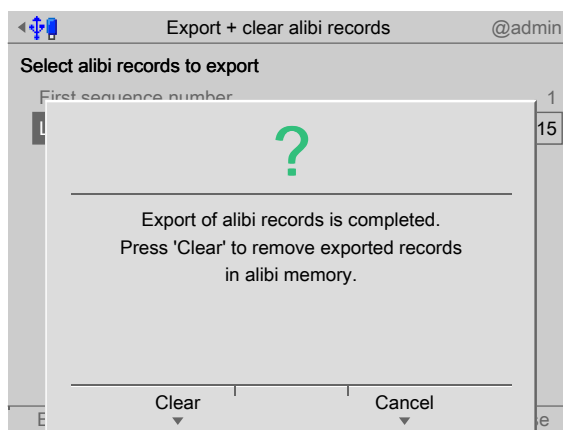

11. Press the [Clear] soft key to remove exported records in alibi memory.

- ▷ An information window is displayed when the process is complete.



12. Press the [OK] soft key to return to the [Alibi memory maintenance] menu.

Note:**Save to USB stick**

The exported data is stored in an XML file on the USB stick in the following directory:

/export/hostname/alibi

where hostname = device name from the network settings

The file name is made up of the date, time, and sequence number range in square brackets and the file extension, e.g.: 2014032014332317 [27-139].xml.

Save to a shared directory

The exported data is stored in an XML file in a shared directory.

The file name is made up of the date, time, and sequence number range in square brackets and the file extension, e.g.: 2014032014332317 [27-139].xml.

6.5.3 Print selection of records

In this menu item (under **Alibi memory maintenance**), a selection of records of the Alibi memory is printed.

Requirements

A printer must be connected, see Chapter [4.1.4](#).

Note:

If no printer has been connected, the message "No printer configured" appears.

Accessible via **MENU** - [Operating] - [System maintenance] - [Alibi memory maintenance] - [Print selection of records] .

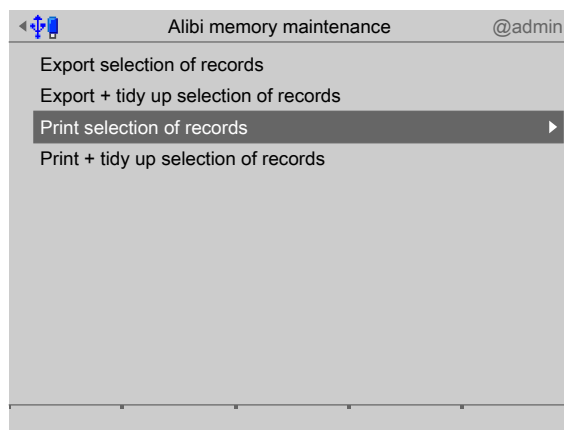

1. Select and confirm [Print selection of records].

▷ A window appears that displays the possible print range.

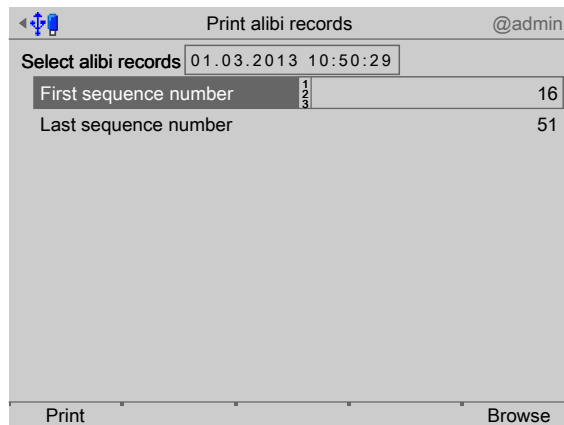

2. Press the [Browse] soft key to search for the first record of the range.

▷ A selection window opens.

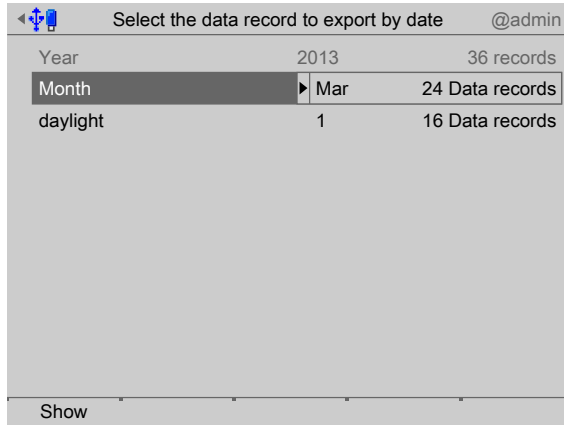

3. Select and confirm the desired record.

▷ A selection window opens.

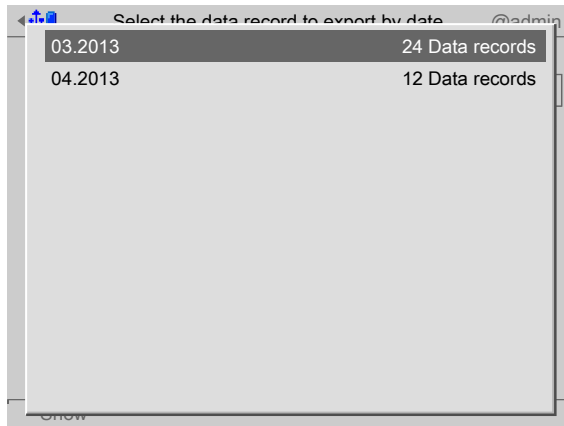

4. Select and confirm the desired record.

5. Press the [Show] soft key.

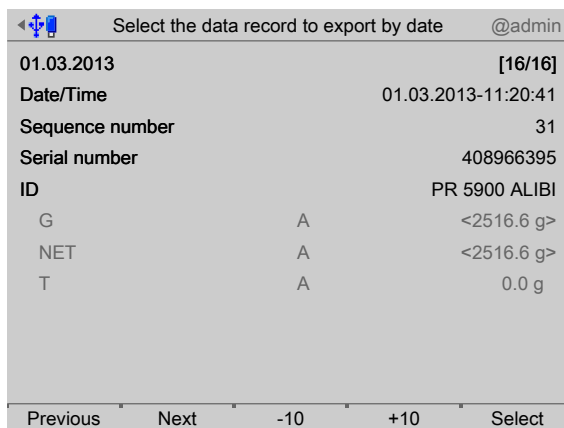

6. Press the [Previous]/[Next] soft key to display the desired record.

7. Press the [Select] soft key to confirm the first record of the range.

▷ Another window opens that displays the sequence number (here: 31) of the selected record under [First sequence number].

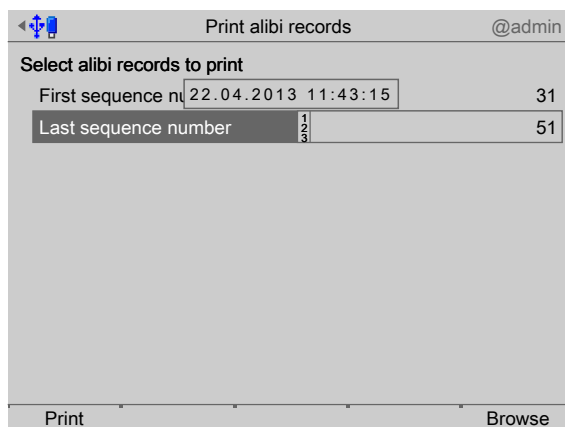

8. Define the last sequence number in accordance with the first sequence number.
9. Press the [Print] soft key to start printing.

For an example of an Alibi printout, see Chapter [10.3](#).

- ▷ A progress window is shown during the printing process. An information window is displayed when the process is complete.

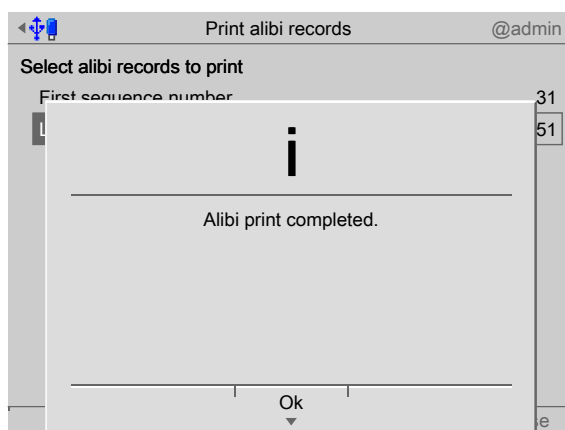

10. Press the [OK] soft key to return to the [Alibi memory maintenance] menu.

6.5.4 Print + tidy up selection of records

In this menu item (under **Alibi memory maintenance**), a selection of records of the Alibi memory is printed and then deleted from the device.

Requirements

A printer must be connected, see Chapter [4.1.4](#).

Note:

If no printer has been connected, the message "No printer configured" appears.

Accessible via **MENU** - [Operating] - [System maintenance] - [Alibi memory maintenance] - [Print + tidy up selection of records] .



1. Select and confirm [Print + tidy up selection of records].
 ▷ A window appears that displays the possible print range.

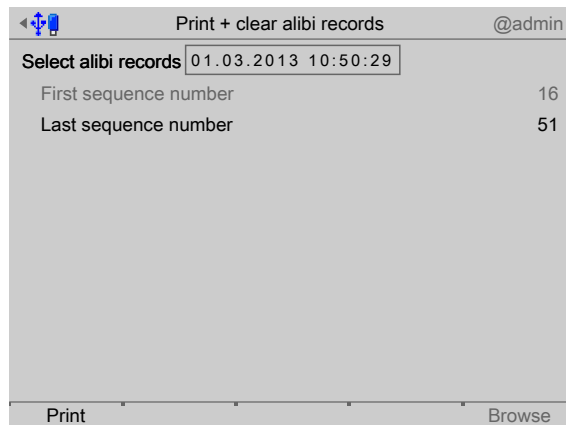

The first record of the range is selected automatically and cannot be changed.

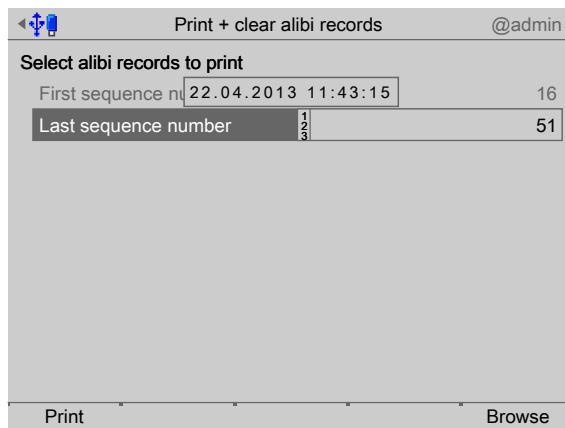

2. Select [Last sequence number] and press the [Browse] soft key to search for the last record of the range.

▷ A selection window opens.

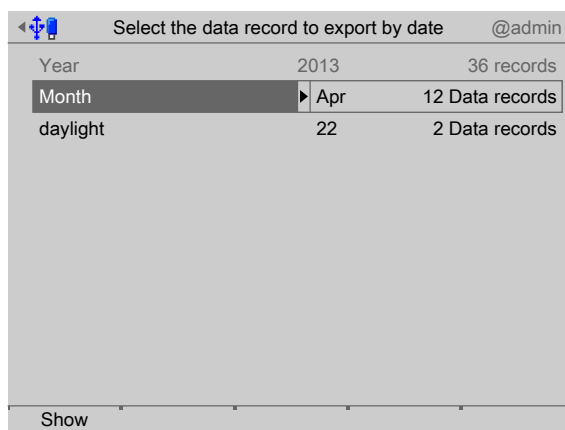

3. Select and confirm the desired record.

▷ A selection window opens.

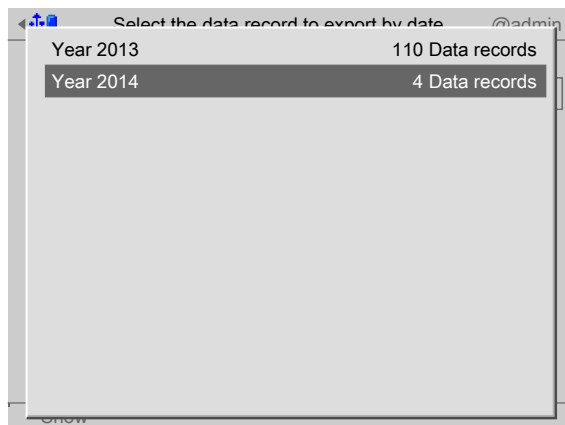

4. Select and confirm the desired record.
5. Press the [Show] soft key.

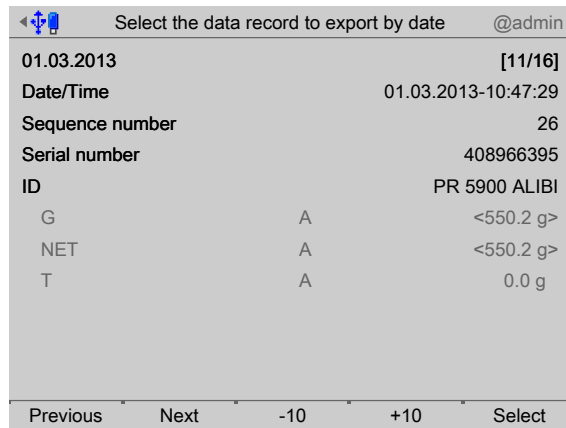

6. Press the [Previous]/[Next] soft key to display the desired record.
7. Press the [Select] soft key to confirm the last record of the range.
8. Press the [Print] soft key to start printing.

For an example of an Alibi printout, see Chapter [10.3](#).

- ▷ A progress window is shown during the printing process. A prompt window appears when printing is complete.

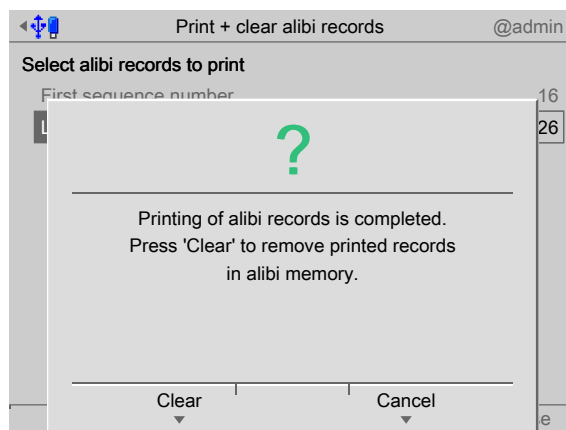

9. Press the [Clear] soft key to remove printed records in alibi memory.
- ▷ An information window is displayed when the process is complete.

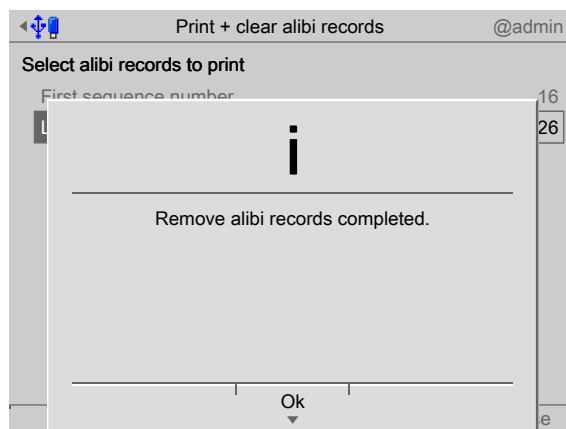

10. Press the [OK] soft key to return to the [Alibi memory maintenance] menu.

6.6 SD card maintenance

In this menu item (under **System maintenance**), an SD card can be formatted or individual backups can be deleted from the SD card.

- [Format SD card], see Chapter 6.6.1.
- [Cleanup backups] (delete), see Chapter 6.6.2.

Accessible via **MENU** - [Operating] - [System maintenance]- [SD card maintenance] .

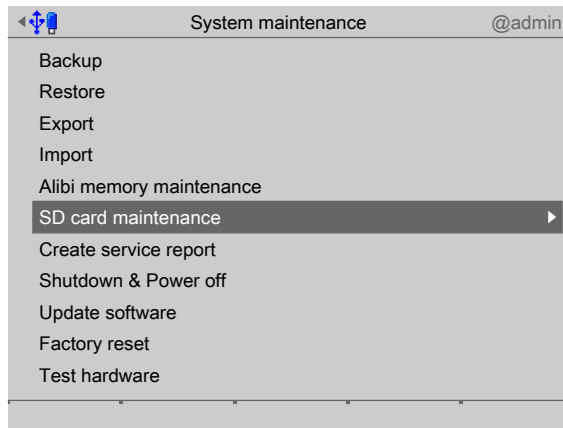

- ▶ Select and confirm [SD card maintenance].
 - ▷ The SD card maintenance window opens.

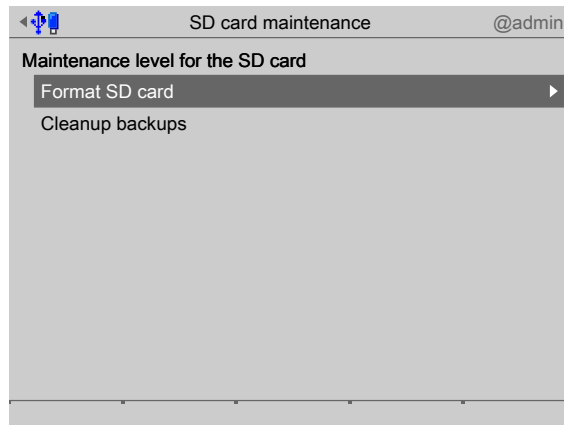

6.6.1 Format SD card

In this menu item (under **SD card maintenance**), the SD card can be formatted and a new backup created.

Accessible via **MENU** - [Operating] - [System maintenance]- [SD card maintenance]- [Format SD card] .

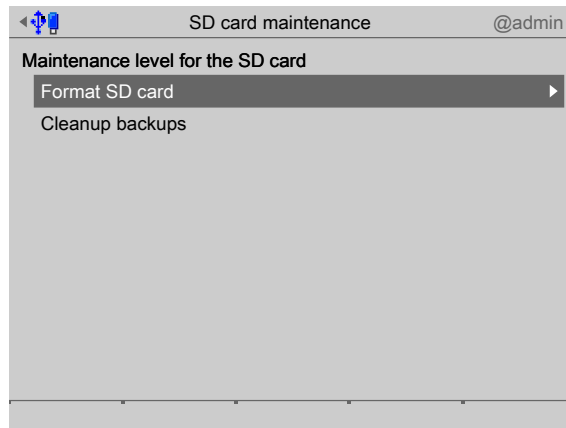

1. Select and confirm [Format SD card].

▷ A prompt window appears.

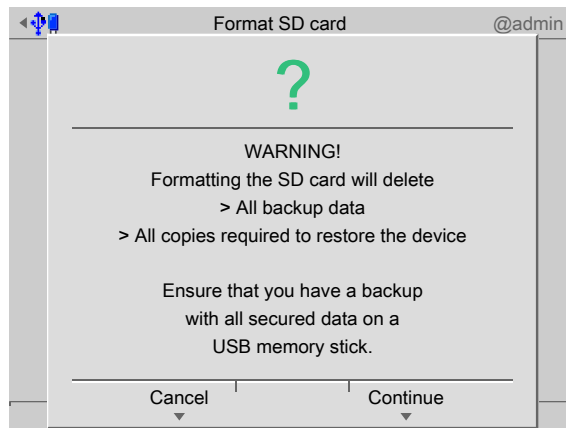

2. Press the [Continue] soft key.

▷ An information window is displayed when the process is complete.

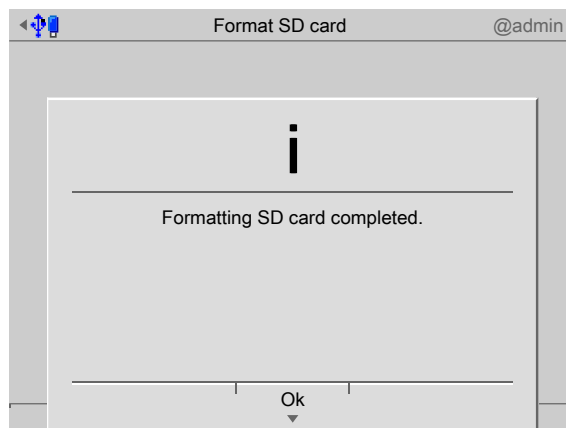

3. Press the [OK] soft key.

▷ A prompt window appears.

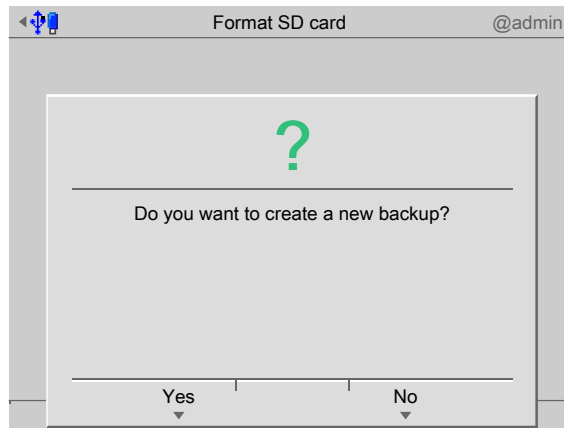

4. Press the [Yes] soft key to create a new backup and return to the [SD card maintenance] menu.

6.6.2 Cleanup backups

In this menu item (under **SD card maintenance**), the backups on the SD card can be viewed and deleted.

Note:

Access to the SD card slows down considerably if too many backups are saved to the card.

If more than 100 backups are saved to the card, not all backups will be accessible.

Accessible via **MENU** - [Operating] - [System maintenance] - [SD card maintenance] - [Cleanup backups] .

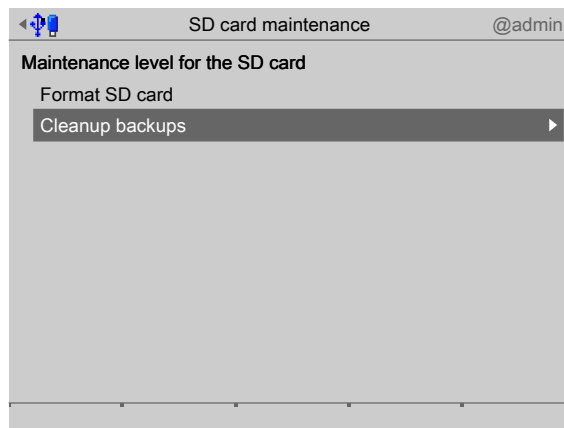

1. Select and confirm [Cleanup backups].
 - ▷ A selection window opens.

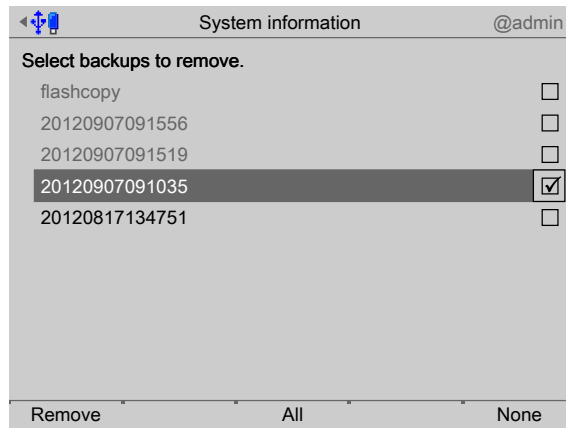

2. Check the appropriate box or press the [All] soft key to select all possible items. Press the [None] soft key to deselect all selected items.

Note:

The last three backups cannot be deleted.

3. Press the [Remove] soft key to delete the selection.
4. Press the **EXIT** key to return to the [System maintenance] menu.

6.7 Create service report

In this menu item (under **System maintenance**), a service report file with the following data is generated:

- All system setup data
- All user management data
- All I/O card data
- Statistics on database and Alibi memory usage
- Error logs
- Logs (audit trails)
- Log files

This file can be sent to customer service for analysis in the event of technical queries.

Note:

For contact info, see Chapter [1.6](#)

Accessible via **MENU** - [Operating] - [System maintenance] - [Create service report] .

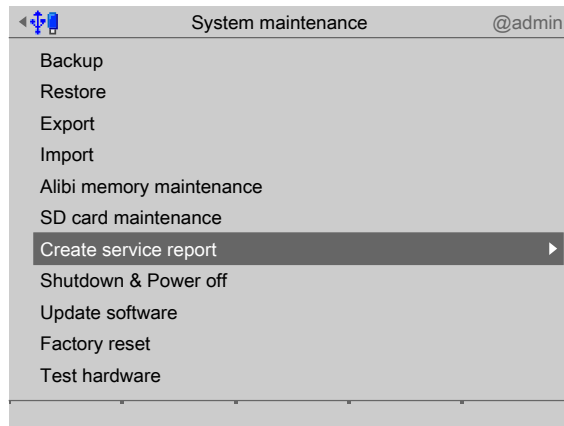

1. Select and confirm [Create service report].

▷ A selection window with the available storage media opens.

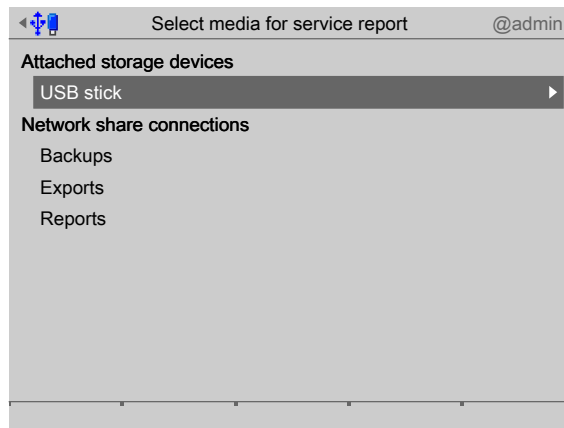

Note:

The connections with the shared directories are only shown if this has been configured in the menu [Operating]- [System setup]- [Network share connections].

2. In this case: Select and confirm USB stick.

Note:

If no USB stick is plugged in, a warning appears.

- Plug in a USB stick and wait until the symbol  appears in the info line.
 - Press the [Retry] soft key.
-

The service report file (pr5900-servicereport-devicename-date + generated number.xml) is saved to the "Service reports" folder on the storage medium (here: USB stick).

▷ An information window is displayed when the process is complete.

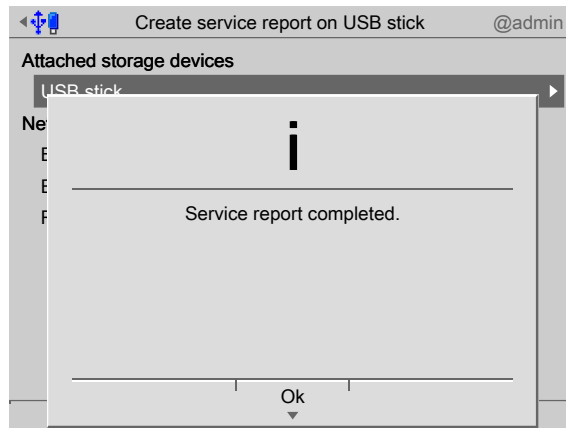

3. Press the [OK] soft key to return to the [System maintenance] menu.
4. Remove the USB stick from the device and insert in a PC to send the file to customer service via e-mail.

6.8 Shutdown & power off

In this menu item (under [System maintenance]), the device is prepared for shutdown, e.g. for option card installation.

- Shutdown & Power off (without SD card), see Chapter [6.8.1](#).

Before switching off, all data is stored on the SD card and automatically restored again after switching on.

- The application will be closed.
- The database and all settings will be saved.
- The device will be shut down.
- The device prompts the user to switch it off.

Accessible via **MENU** - [Operating] - [System maintenance] - [Shutdown & Power off] .

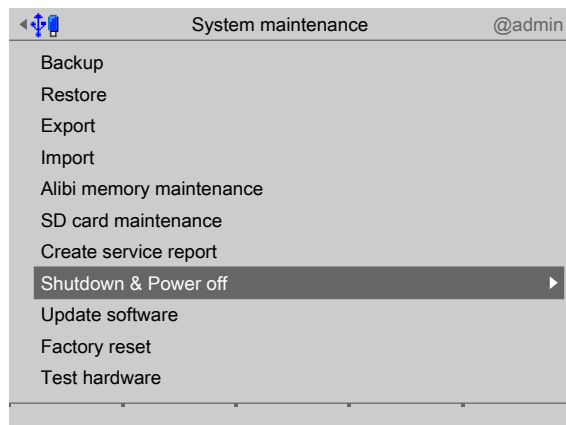

1. Select and confirm [Shutdown & Power off].
 - ▷ A prompt window appears.

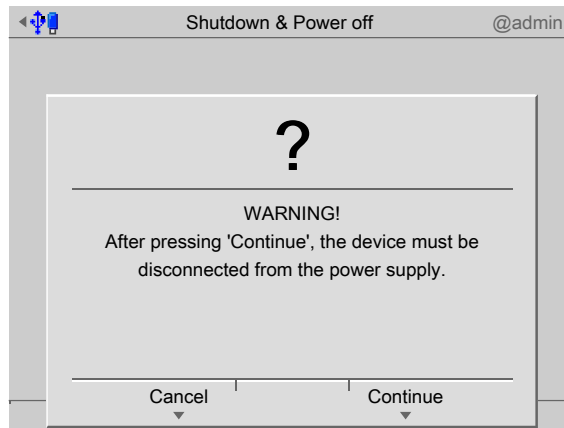

2. Press the [Continue] soft key.
 - ▶ Messages appear when the data is saved and the application is ended.
The following message appears:
You must now switch power off!
3. Disconnect the power plug.

6.8.1 Shutdown & Power off (without SD card)

CAUTION

Possible data loss!

If no SD card is inserted or the card cannot be read, **no** data is saved after the [Continue] soft key is pressed.

- ▶ An SD card must be inserted and detected by the device.

A prompt window opens if no SD card is inserted or the card cannot be read.

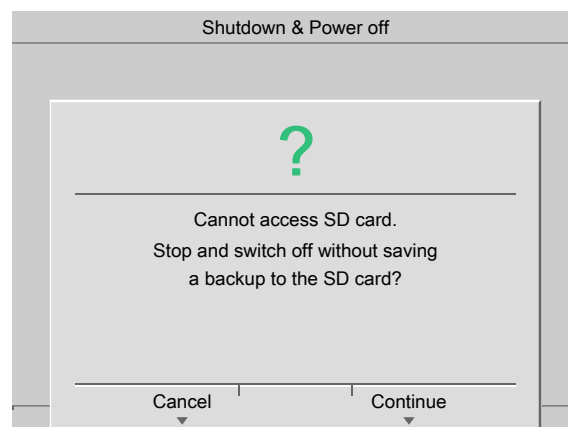

1. Press the [Cancel] soft key.
2. Check the SD card or insert one.
3. Press [Shutdown & Power off] again.

6.9 Update software

In this menu item (under **System maintenance**), the software on the device is replaced with the latest software.

There are two ways to update the software:

- via soft key (one-click software update), see Chapter [6.9.1](#).
- via menu
 - [Update software], see Chapter [6.9.2](#).
 - [Update software with FlashIt], see Chapter [6.9.3](#).
 - [Update software for the remote terminal], see Chapter [6.9.4](#).
 - [Remove application], see Chapter [6.9.5](#).
 - [Restore software from SD card], see Chapter [6.9.6](#).

Accessible via **MENU** - [Operating] - [System maintenance] - [Update software] .

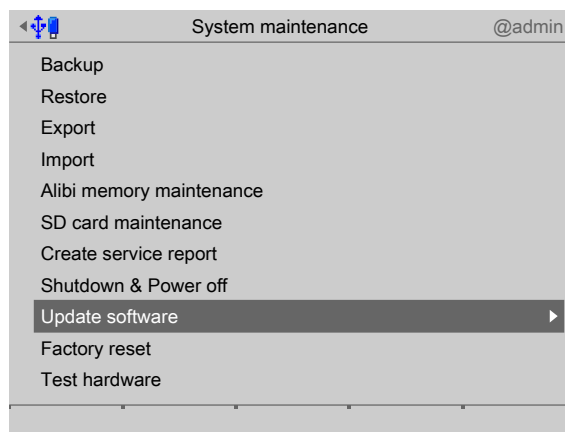

► Select and confirm [Update software].

▷ The Update software menu opens.

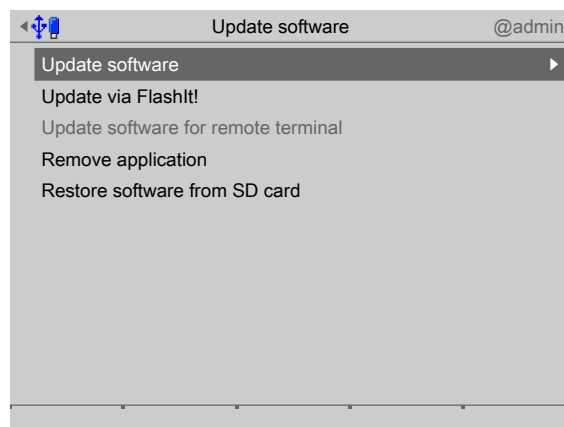

6.9.1 Update (soft key)

In this menu item (under **Update software**), the software on the device is replaced with the latest software via the company network (one-click software update).

This is a simple method for when new software versions from a department are provided on the company's central network and these are to be installed by authorized operators.

To update the software via soft key, the following requirements must be met:

- Network share connection "ONECLICKUPDATE" has been created in the menu [Operating] - [System setup] - [Network share connections].
- If these files exist, they must have the following names:
 - pr5900-r01-bios.bin
 - pr5900-r01-firm.bin
 - pr5900-appl.bin
 - pr5900-labl.bin (optional)
- For BIOS and Firmware:
 - CAL switch 2 must be open and the
 - [Settings locked] parameter must be deactivated for all weighing points whilst W&M mode is selected.
- There are no restrictions for the application and labels.

Accessible via **MENU** – [Operating] - [Update].

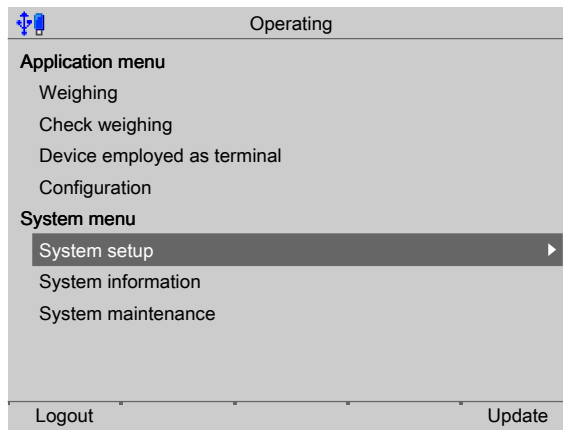

1. Press the [Update] soft key.

▷ A prompt window opens.

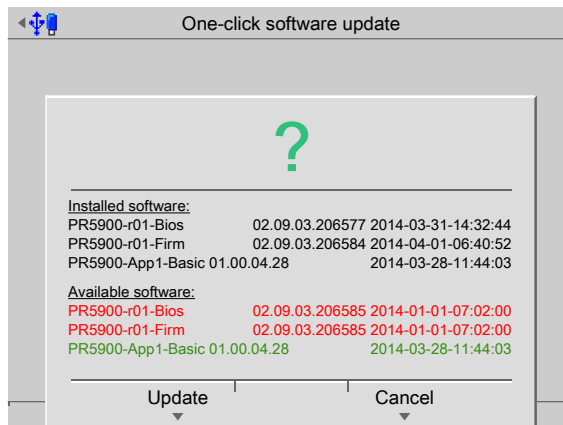

The installed and available software is listed.

Green: Installed and available versions are the same.

Red: Installed and available versions are different.

2. Press the [Update] soft key.

▷ A database backup is created in a temporary folder on the SD card.

The software is loaded onto the device. The device runs a cold start. The database is restored from the temporary backup.

6.9.2 Update software

In this menu item (under **Update software**), the software on the device is replaced with the latest software.

The software can be updated from an attached storage medium or a shared directory:

- [SD card], see Chapter [6.9.2.1](#).
- [SD card (factory data)], see Chapter [6.9.2.2](#).
- [USB stick], see Chapter [6.9.2.3](#).
- Shared directory (Network share connections), see Chapter [6.9.2.4](#).

Note:

The connections with the shared directories are only shown if this has been configured in the menu [Operating]- [System setup]- [Network share connections] .

Accessible via **MENU** - [Operating]- [System maintenance]- [Update software]- [Update software] .

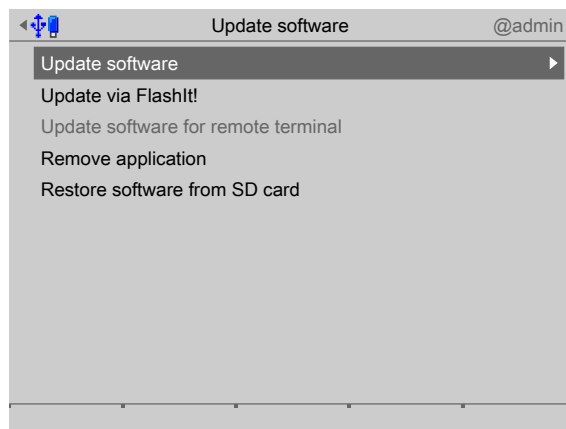

▶ Select and confirm [Update software].

▷ The window listing the available storage media is shown.

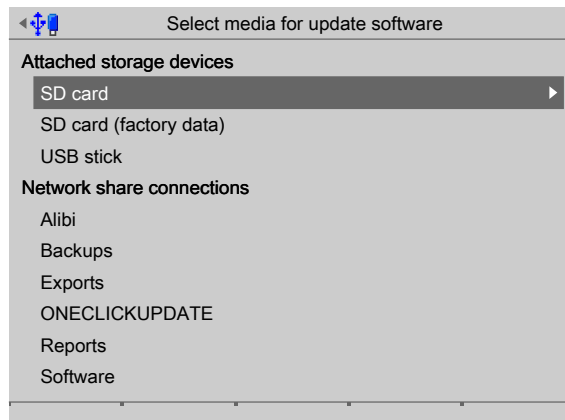

6.9.2.1 SD card

In this menu item (under **Update software**), a software version saved on an SD card is restored.

Accessible via **MENU** - [Operating] - [System maintenance]- [Update software]- [Update software]- [SD card] .

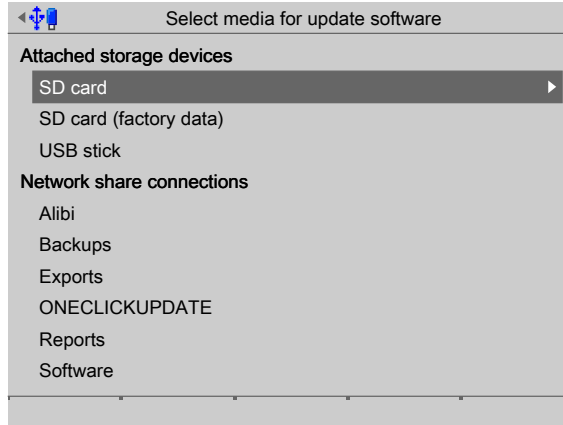

1. Select and confirm [SD card].

▷ A selection window opens.

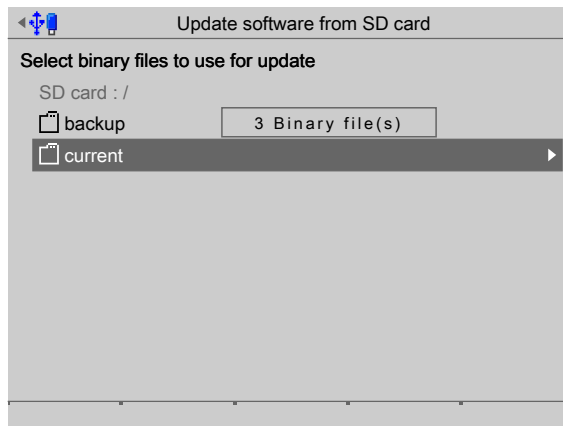

2. in this case: select and confirm [current].

▷ A selection window opens.

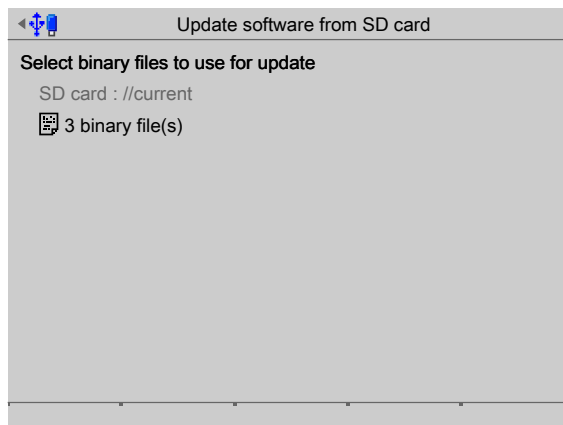

3. In this case: select and confirm [3 binary files].

▷ A selection window opens.

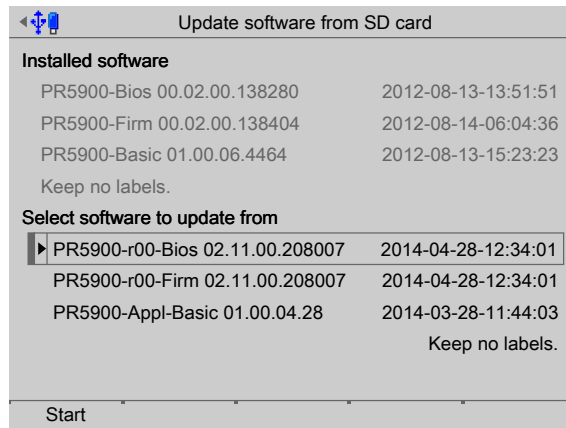

The software installed on the device and available on the SD card is listed.

Select software, see also Chapter [6.9.2.3](#).

4. Press the [Start] soft key to start the update.
 - ▷ A prompt window appears.

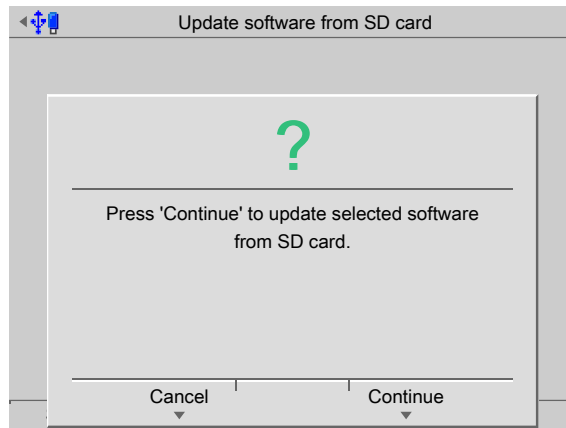

5. Press the [Continue] soft key.
 - ▷ The software is updated on the device. The device runs a cold start.

6.9.2.2 SD card (factory data)

In this menu item (under **Update software**), the software on the device is restored to the factory settings.

Accessible via **MENU** - [Operating] - [System maintenance]- [Update software]- [Update software] .

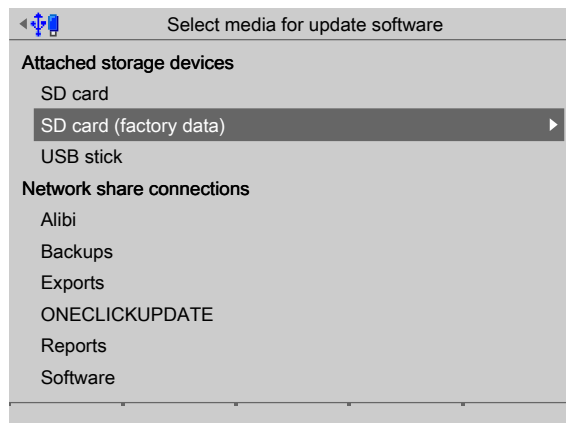

1. Select and confirm [SD card (factory data)].

▷ A selection window opens.

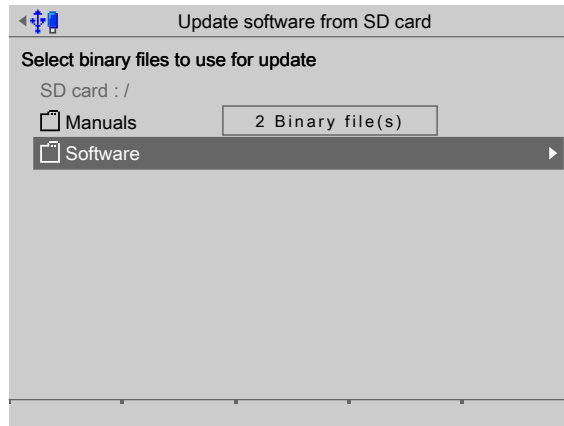

2. In this case: select and confirm [Software].

▷ A selection window opens.

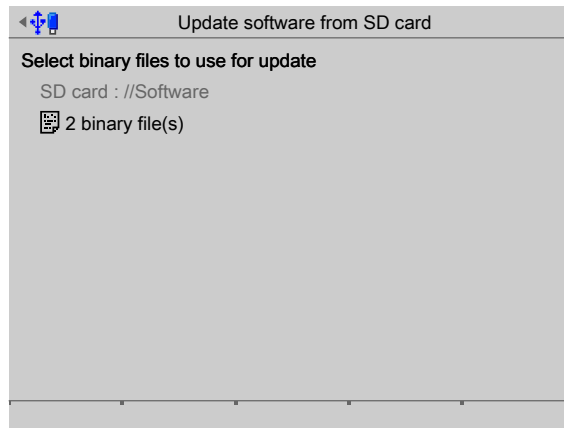

3. In this case: select and confirm [2 binary files].

▷ A selection window opens.

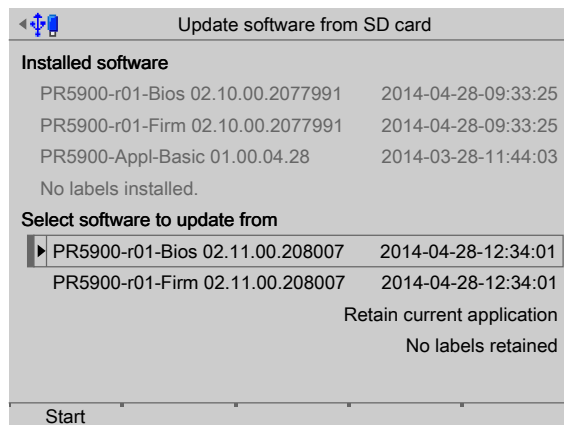

The software installed on the device and the factory settings on the SD card are listed.

Select software, see also Chapter [6.9.2.3](#).

4. Press the [Start] soft key to start the update.

▷ A prompt window appears.

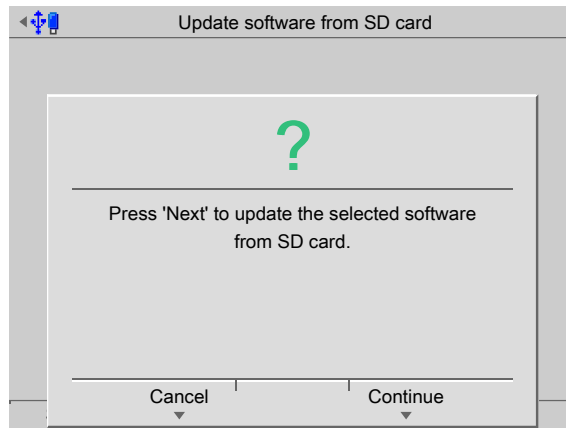

5. Press the [Continue] soft key.
 - ▷ The software is updated on the device. The device runs a cold start.

6.9.2.3 USB stick

In this menu item (under **Update software**), a software version saved on a USB stick is restored.

Note:

The software file names must not be changed!

Accessible via **MENU** - [Operating] - [System maintenance]- [Update software]- [Update software]- [USB stick] .

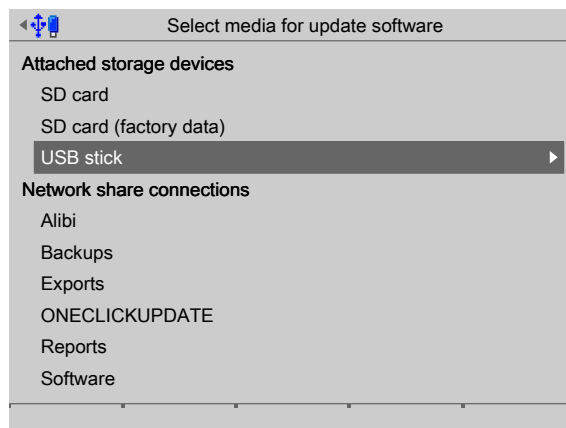

1. Select and confirm [USB stick].

Note:

If no USB stick is plugged in, a warning appears.

- Plug in a USB stick and wait until the symbol  appears in the info line.
 - Press the [Retry] soft key.
-

- ▷ A selection window opens.

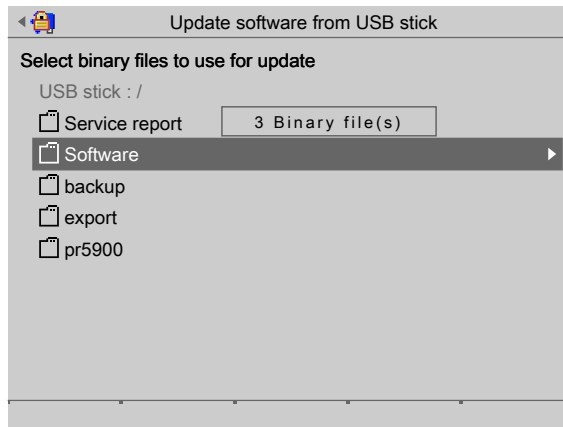

The content shown is an example.

2. In this case: select and confirm [Software].

- ▷ A selection window opens.

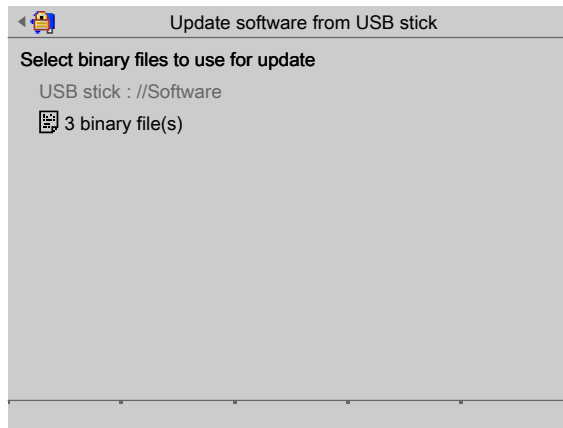

3. In this case: select and confirm [3 binary files].

If the storage medium contains BIZ files:

- ▷ A prompt window appears.

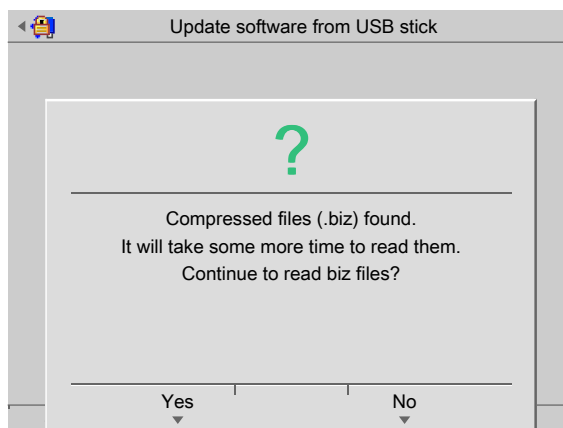

4. Press the [Yes] soft key.

▷ A selection window opens.

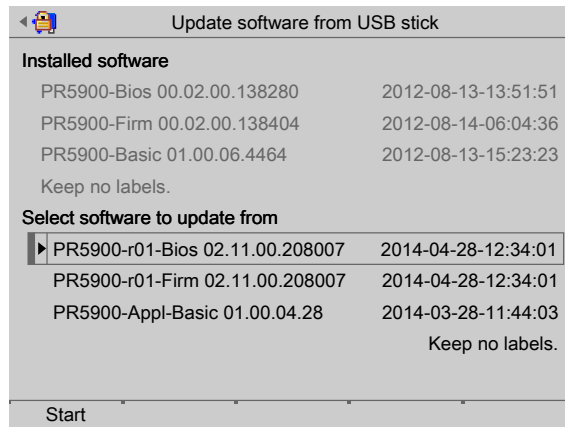

The software installed on the device and available on the USB stick is listed. If different versions are available, the version to be installed can be selected.

Note:

Checking the versions: If e.g. 02.10 firmware is to be combined with a 02.00 BIOS, the update cannot be started.

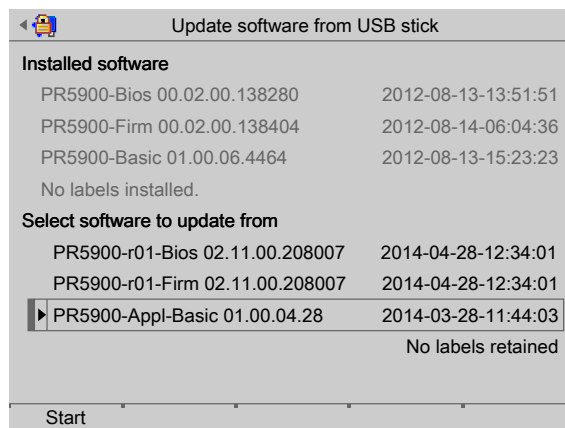

In this case: the BIOS and firmware must be updated and the application must be retained.

5. Select and confirm the third line.

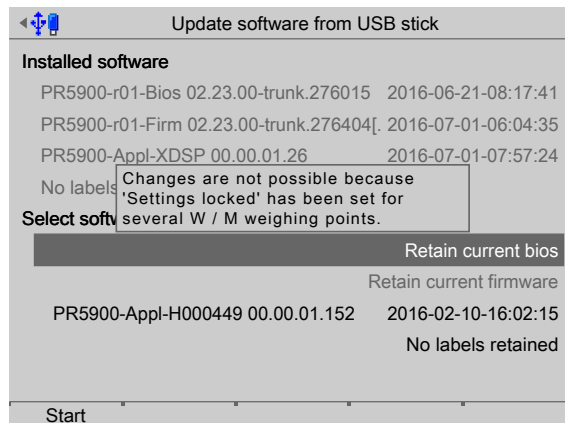

Note:

BIOS and firmware cannot be updated if CAL switch 2 is closed or if the [Settings locked] parameter is activated whilst [W&M mode] is selected for at least one weighing point.

▷ A selection window opens.

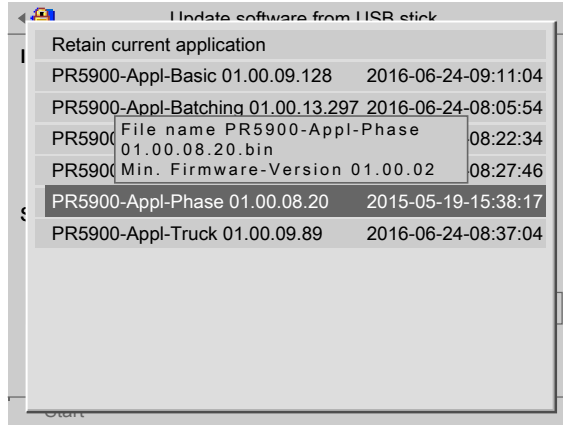

6. Select and confirm the desired file.

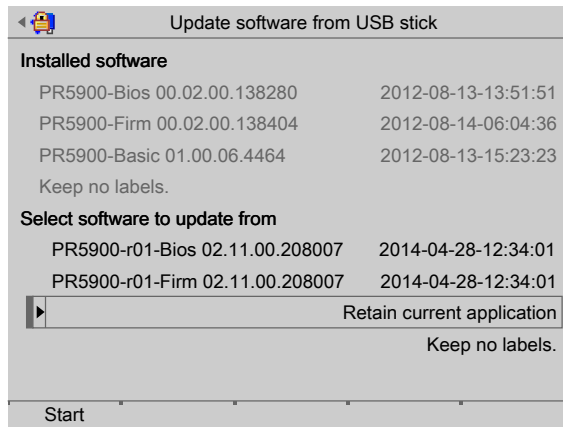

7. Press the [Start] soft key to start the update.

▷ A prompt window appears.

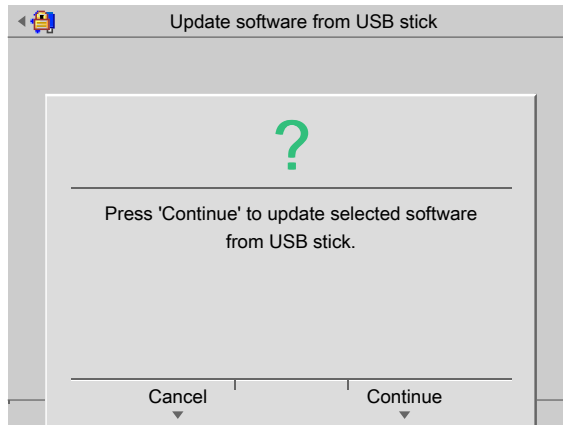

8. Press the [Continue] soft key.

- ▷ The BIOS and firmware are updated on the device. The application is retained. The device runs a cold start.

6.9.2.4 Shared directory

In this menu item (under **Update software**), a software version saved in a shared directory (under Network share connections) is restored.

Note:

The connections with the shared directories are only shown if this has been configured in the menu [Operating]- [System setup]- [Network share connections] .

Requirements

- The software files must be available in the folder (in this case: [Software]).

Accessible via **MENU** - [Operating]- [System maintenance]- [Update software]- [Update software] in this case: [Software] folder.

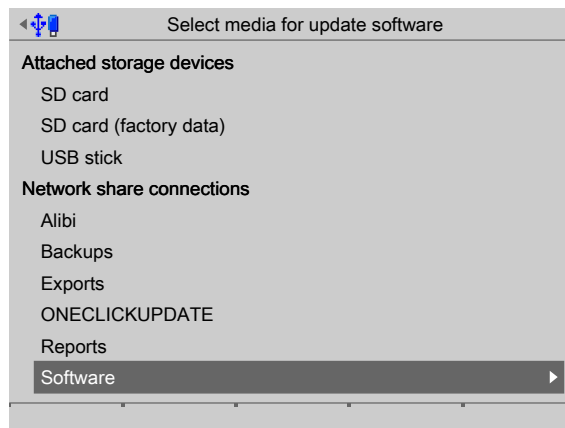

1. In this case: select and confirm [Software].

- ▷ A selection window opens.

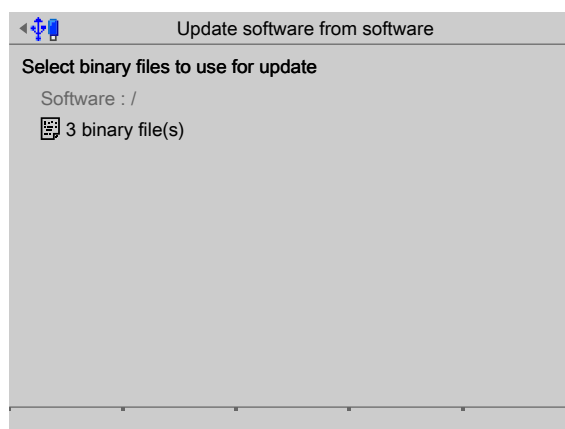

2. In this case: select and confirm [3 binary files].

- ▷ A selection window opens.

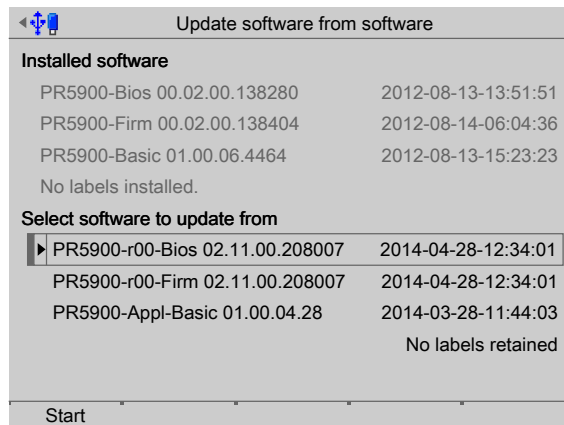

The software installed on the device and available in the network share connection (in this case: "Software" folder) is listed.

Select software, see also Chapter [6.9.2.3](#).

3. Press the [Start] soft key to start the update.

- ▷ A prompt window appears.

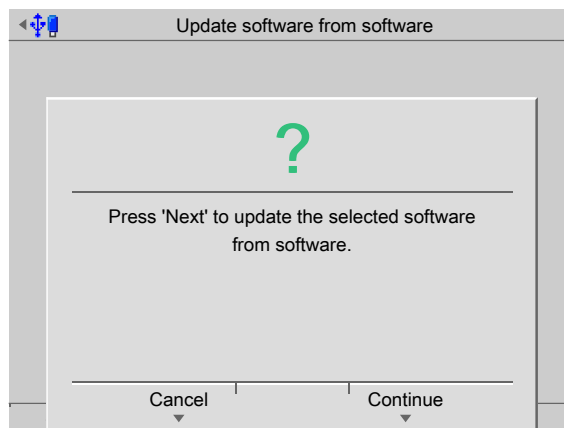

4. Press the [Continue] soft key.

- ▷ The software is updated on the device. The device runs a cold start.

6.9.3 Update software with FlashIt

In this menu item (under **Update software**), the software is updated with FlashIt from a notebook/PC.

Note:

This menu item is not available for the blackbox device.

Requirements:

- The FlashIt! program (on the CD supplied) must be installed on the notebook/PC.
- The device must be connected to the notebook/PC directly or via a network.
- The software files must be saved on the notebook/PC.

Accessible via **MENU** - [Operating] - [System maintenance] - [Update software] - [Update software with FlashIt] .

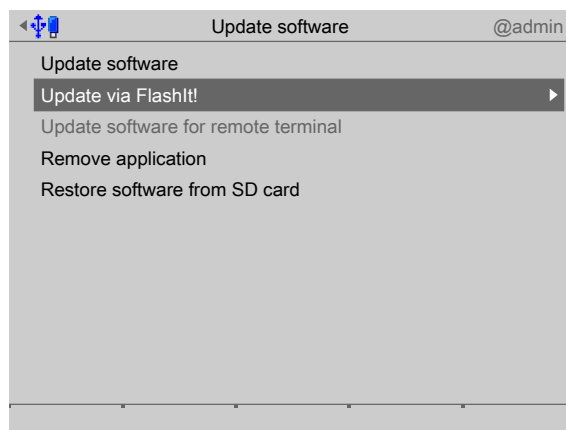

1. Select and confirm [Update software with FlashIt].

▷ A prompt window appears.

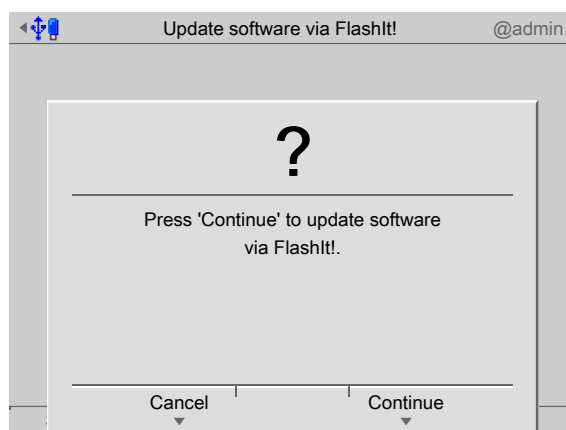

2. Press the [Continue] soft key.

▷ A window appears on the display.

```
Wait for FlashIt!
IpAddr=172.24.20.111
```

The device waits for the update to start on the notebook/PC.

3. Double-click the corresponding file in the "Explorer."
 - ▷ "FlashIt!" opens and the file is displayed next to [Select].

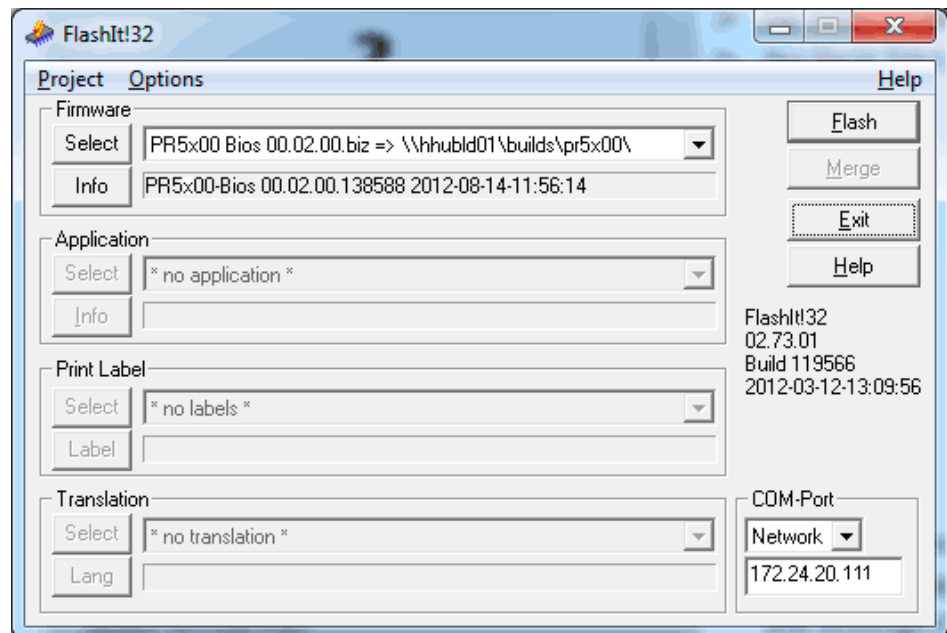

The files are installed in the following order:

- PR5x00-Firm xx
- PR5x00-Bios xx (only when required for the firmware)
- Application (in this case: PR5x00-Basic xx)

Note:

If only the application is to be flashed, there is no need to flash the firmware.

If the CAL switch 2 is closed or if the [Settings locked] parameter is activated whilst [W&M mode] is selected for at least one weighing point, flashing of the BIOS or firmware is aborted with an error message.

4. Select [Network].
5. Enter the device IP address (shown in the window on the device display).
6. Click [Flash] to start the procedure.
 - ▷ A confirmation prompt appears when the BIOS is updated.

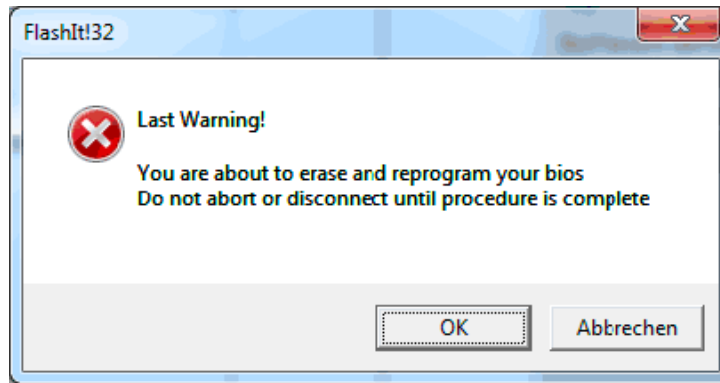

7. Click [OK].
 - ▷ The process starts now.

The window appears on the device display after the file has been loaded onto the device.
8. The next files can then be loaded.
 - ▷ After the last file has been loaded, the window appears again on the device display.
9. Press the **EXIT** key to stop the flash process.
 - ▷ The device runs a cold start.

6.9.4 Update software for remote terminal

In this menu item (under **Update software**), the existing software for the remote terminal is updated.

Prerequisite

- The remote terminal is connected to the device.

Accessible via **MENU** - [Operating]- [System maintenance]- [Update software]- [Update software for remote terminal] .

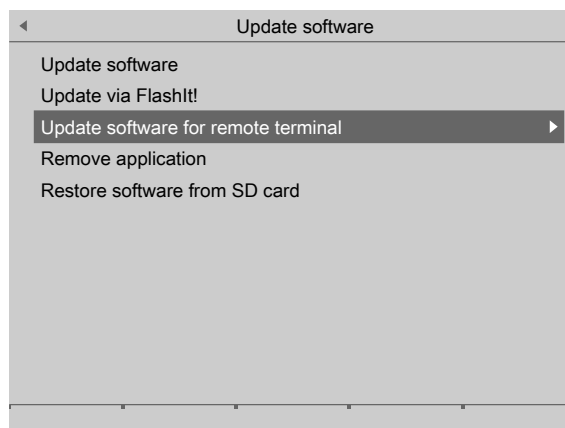

- ▶ Select and confirm [Update software for remote terminal].

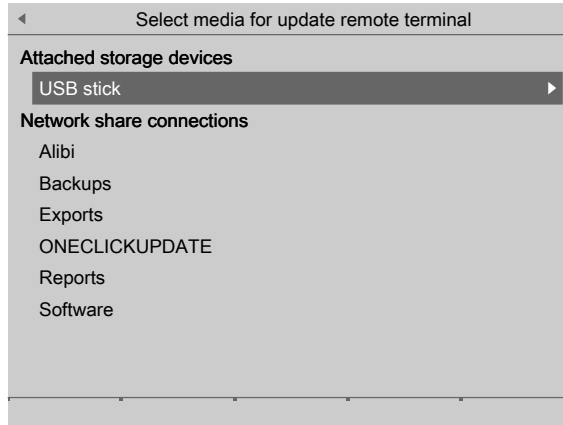

Example: Attached storage devices [USB stick], see Chapter [6.9.2.3](#).

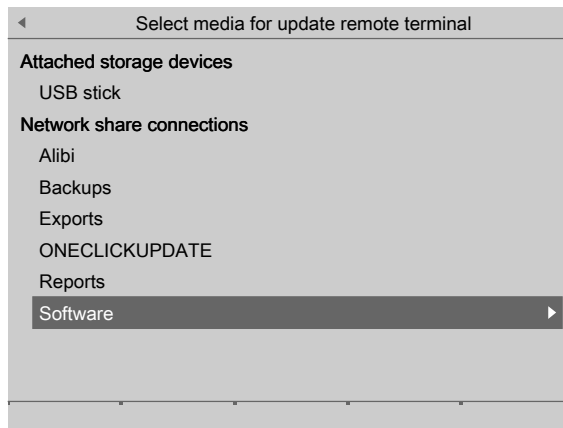

Example: Network share connections [Software], see Chapter [6.9.2.4](#).

6.9.5 Remove application

In this menu item (under **Update software**), the existing application is deleted along with all application-specific settings and database tables.

This is required when developing applications that are to be loaded onto the device with PR 1750.

Accessible via **MENU** - [Operating] - [System maintenance]- [Update software]- [Remove application] .

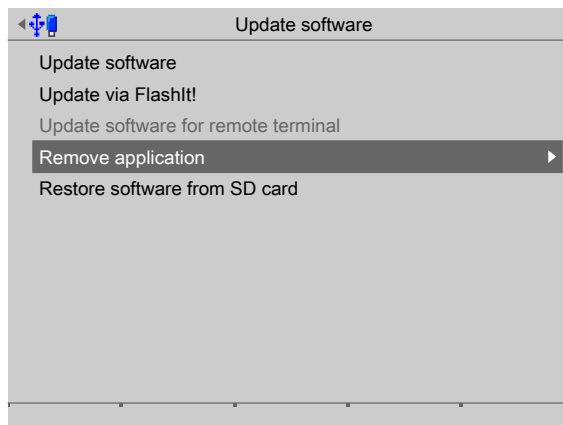

1. Select and confirm [Remove application].

- ▷ A prompt window appears.

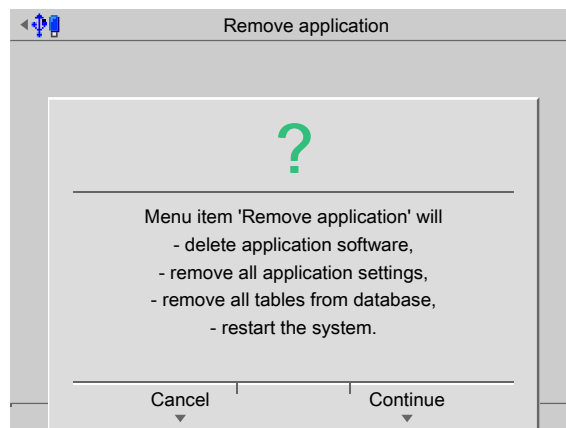

2. Press the [Continue] soft key.
- ▷ The application, settings and database tables are removed. The device runs a cold start.

6.9.6 Restore software from SD card

In this menu item (under **Update software**), the software is restored from the SD card if it is used in a replacement device.

The application software and the associated settings and database tables are loaded onto the device without a prompt, see the PR 5900 installation manual under [Repair and maintenance]- [Repair]- [Replace device].

Accessible via **MENU** - [Operating] - [System maintenance]- [Update software]- [Restore software from SD card].

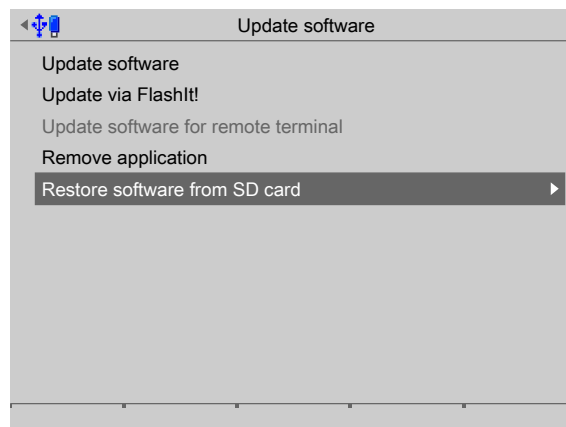

1. Select and confirm [Restore software from SD card].

- ▷ A prompt window appears.

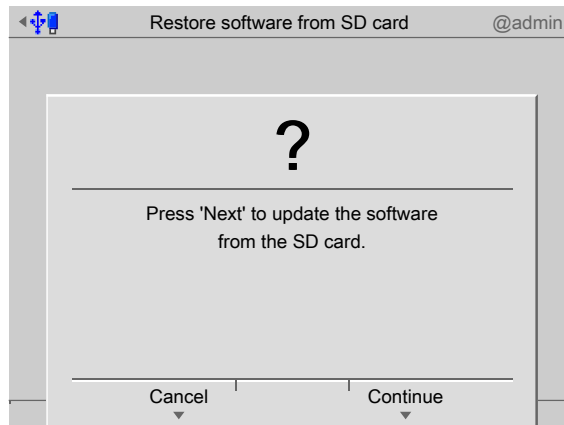

2. Press the [Continue] soft key.
 - ▷ The application software with the associated settings and database tables is loaded onto the device. The device runs a cold start.

6.10 Factory reset

In this menu item (under **System maintenance**), the following data is reset to factory settings:

- All calibration data
- All system settings (including licenses and user management)
- All Alibi memory records
- All database tables

Note:

The device can only be reset to the factory settings when overwrite protection is deactivated; see Chapter [2.7](#).

Accessible via **MENU** - [Operating] - [System maintenance]- [Factory reset].

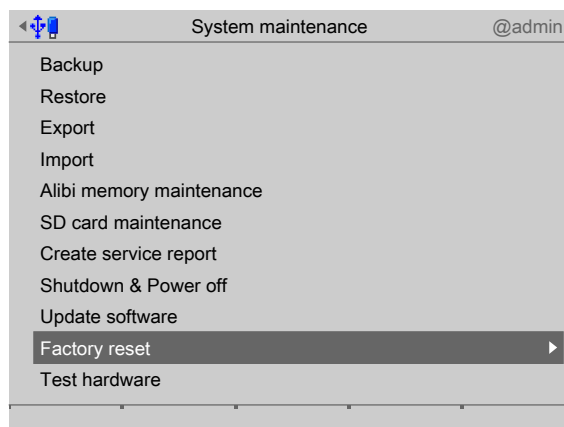

1. Select and confirm [Factory reset].

- ▷ A prompt window appears.

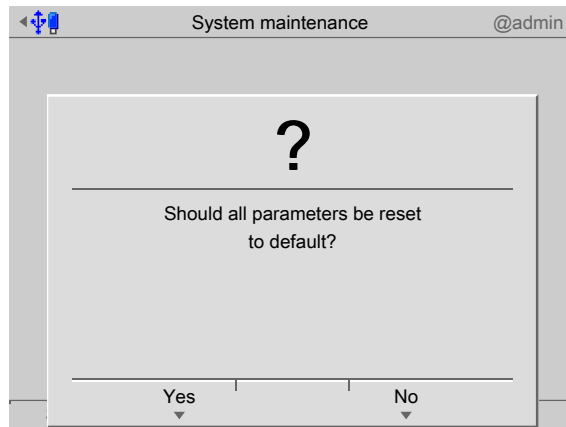

2. Press the [Yes] soft key.
▷ The device restarts with the factory settings.

6.11 Test hardware

In this menu item (under **System maintenance**), the display, keyboard and input/output cards are tested.

- [Display test], see Chapter [6.11.1](#).
- [Keyboard test], see Chapter [6.11.2](#).
- [I/O cards test], see Chapter [6.11.3](#).

Accessible via **MENU** - [Operating] - [System maintenance]- [Test hardware] .

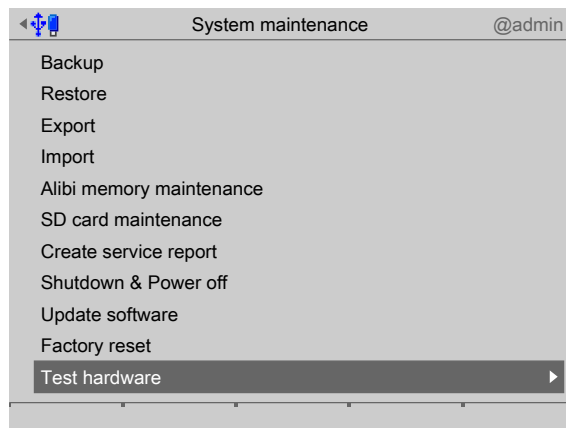

- ▶ Select and confirm [Test hardware].

- ▷ The Test hardware window is shown.

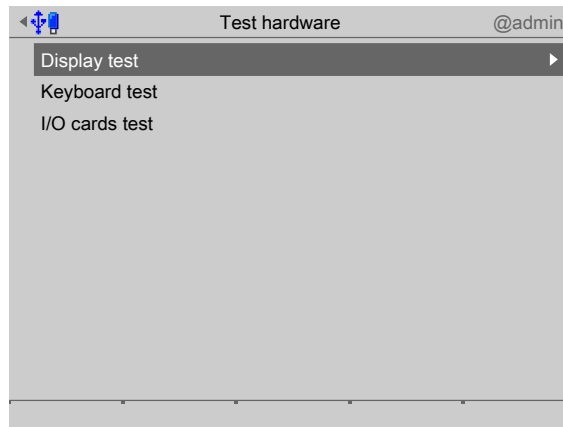

6.11.1 Display test

In this menu item (under **Test hardware**), the display is tested.

Accessible via **MENU** - [Operating] - [System maintenance]- [Test hardware]- [Display test] .

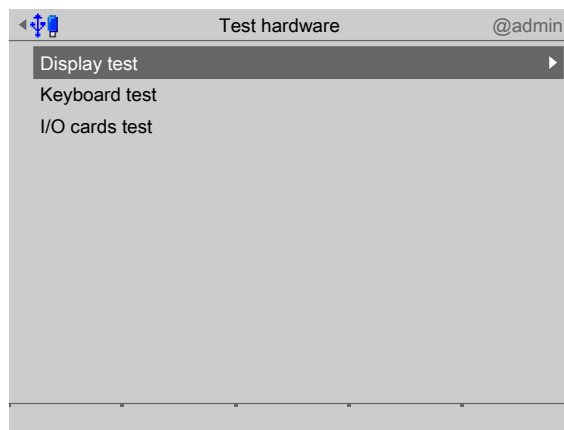

1. Select and confirm [Display test].
 - ▷ An information window is displayed.

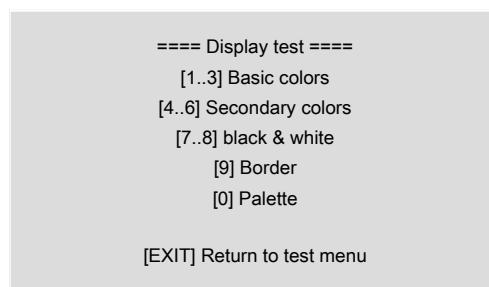

2. Press the corresponding keys to test the display.
3. Press the **EXIT** key to return to the test menu.

6.11.2 Keyboard test

In this menu item (under **Test hardware**), the keyboard is tested.

Accessible via **MENU** - [Operating] - [System maintenance] - [Test hardware] - [Keyboard test] .

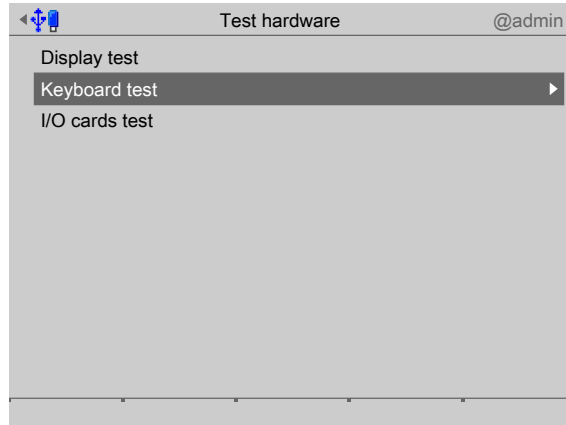

1. Select and confirm [Keyboard test].
 ▷ The device front is displayed.

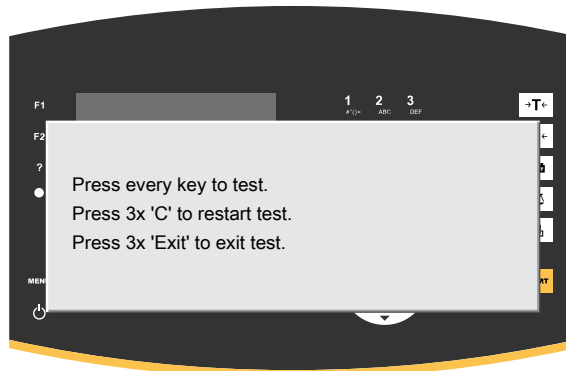

2. Press each key to test the keyboard.
 ▷ The key that is pressed is checked off in green (light/dark green) on the display.



When all keys have been checked off, an info window appears



Errors are shown in red/yellow crosses and question marks.



Display	Cause
red/yellow cross	Keys are bypassed (e.g. short circuit in the foil-covered keyboard)
red/yellow question mark	Question mark for unknown key position (e.g. keyboard connected incorrectly)

3. Press the **EXIT** key three times to return to the test menu.

6.11.3 I/O cards test

In this menu item (under **Test hardware**), the input/output cards are tested. Accessible via **MENU** - [Operating] - [System maintenance]- [Test hardware] .

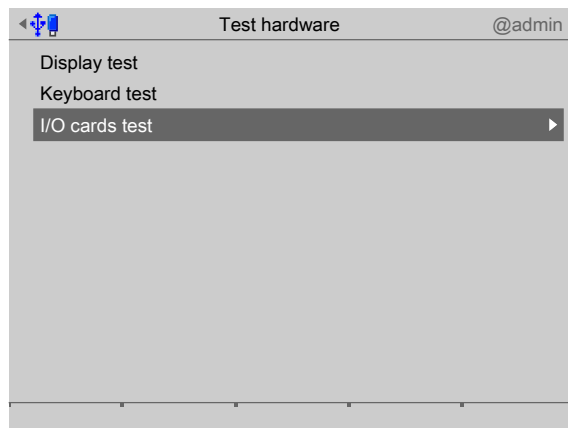

- ▶ Select and confirm [I/O cards test].

▷ A selection window opens.

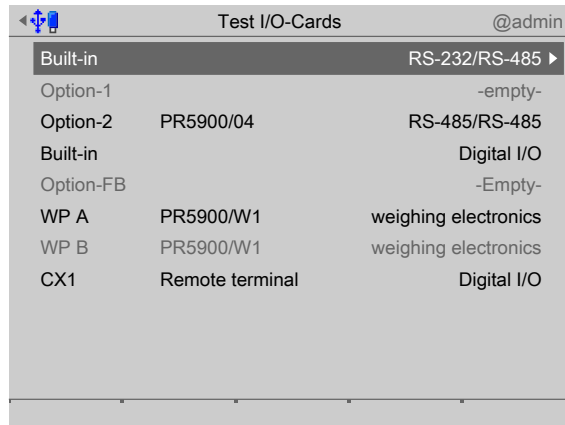

The test process differs depending on the function of the card

- For the various [test modes], see Chapter [6.11.3.1](#).
- Example: PR 5900/W1, see Chapter [6.11.3.2](#).
- Adapting the analog output: PR 5900/07, see Chapter [6.11.3.3](#).
- Example: PR 5900/12, see Chapter [6.11.3.4](#).

6.11.3.1 Test modes

There are different test modes for the **I/O cards test** of the analog and digital inputs and outputs:

- Test mode 1 [Monitoring]
- Test mode 2 [Internal test]
- Test mode 3 [External test]

Note:

If a card is not used by the application currently loaded, test mode 3 [External test] is selected automatically. The [Monitoring] and [Internal test] test modes are not available in this case.

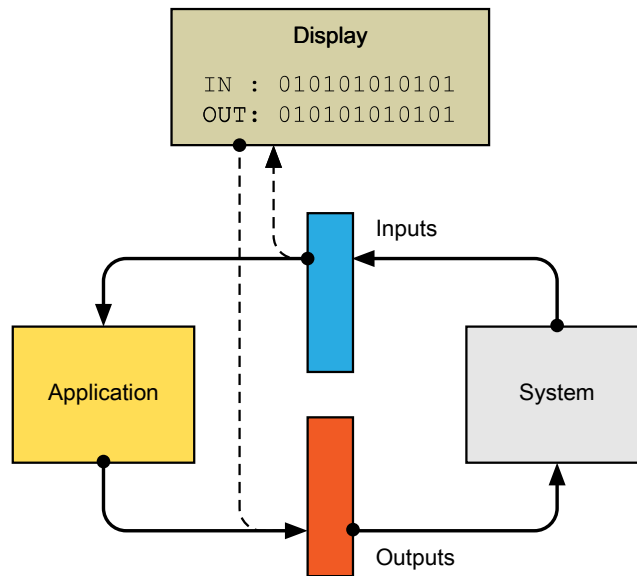
Test mode 1**Active PLC:**

- The physical inputs of the system are directed to the PLC (application).
- The physical outputs of the system are set by the PLC (application).
- The physical inputs and outputs are displayed (display).

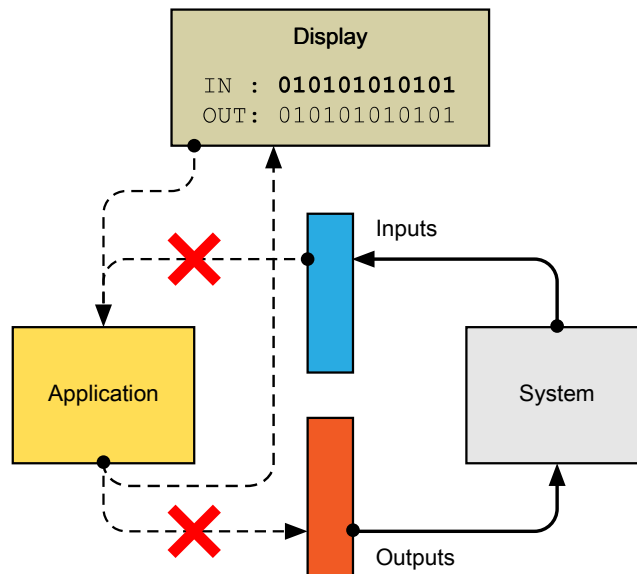
Test mode 2**Active PLC:**

- The entered input values are sent to the PLC (application).
- The PLC output is displayed (display).
- The physical inputs and outputs of the system are deactivated and passive (in secured condition).

Test mode 3

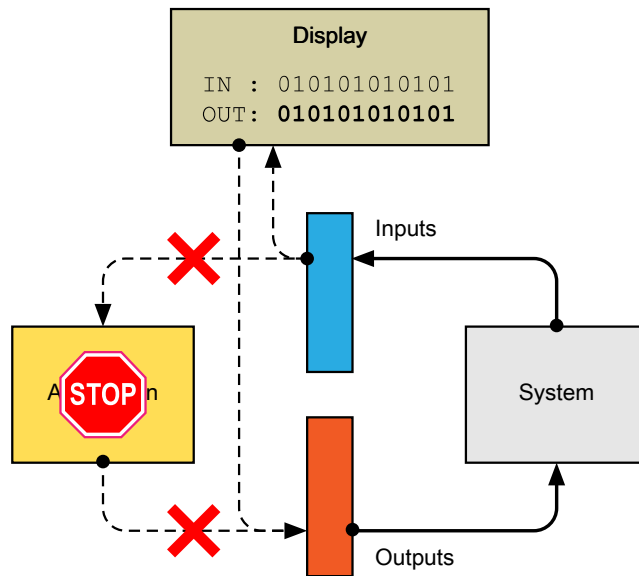

Deactivated PLC:

- The physical inputs are displayed (display).
- Output values can be entered.
- The given output values are set on the physical outputs.

6.11.3.2 Example: PR 5900/W1

Example test (under **I/O cards test**) of an analog input card.

Accessible via **MENU** - [Operating] - [System maintenance]- [Test hardware]- [I/O cards test] in this case, card: PR 5900/W1.

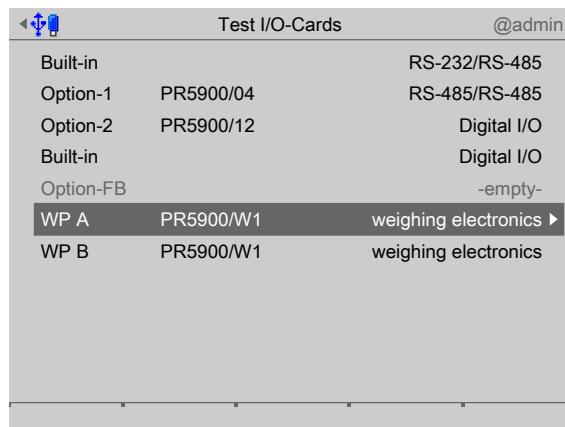

1. Select and confirm the desired card (here: PR 5900/W1).

Note:

If a remote terminal is connected to Maxxis, an additional line appears here:
 "CX1 Remote terminal Digital I/O".

- ▷ An information window is displayed.

WP A		PR5900/W1weighing electronics
Gross		0.0 g
Net		0.0 g
Tare		0.0 g
Zero correction		-0.177 g
InputVoltage		0.040310 mV/V
Dead load voltage		0.040382 mV/V

[Gross], [Net], [Tare]

Display the current values.

[Zero correction]

Displays the zeroset range already used.

[InputVoltage]

The displayed value x input voltage (e.g. 12 V) gives the value to be measured; see the PR 5900 installation manual under [Device installation] - [Accessories] - [PR 5900/07 analog input and output] .

[Dead load voltage]

Displays the value calibrated for the dead load.

2. Press the [Analog test] soft key.
 - ▷ An information window is displayed.

WP A		PR5900/W1weighing electronics
Gross		3000.0 g

3. Press the [10x Res.] soft key if necessary to display the weight value in an increased resolution (10-fold).

Press the soft key again to switch off the increased resolution (10-fold).
4. Press **EXIT** to return to the previous window.

6.11.3.3 Adapting the analog output: PR 5900/07

Example test (under **I/O cards test**) of an analog input/output card.

The output current can be adjusted in small ranges. This is required if small deviations from the nominal value occur in a connected PLC.

Accessible via **MENU** - [Operating] - [System maintenance]- [Test hardware]- [I/O cards test] in this case, card: PR 5900/07.

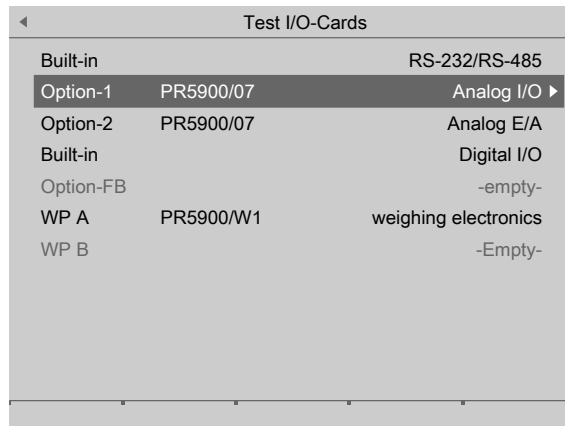

1. Select and confirm the desired card (here: PR 5900/07).

▷ An information window is displayed.

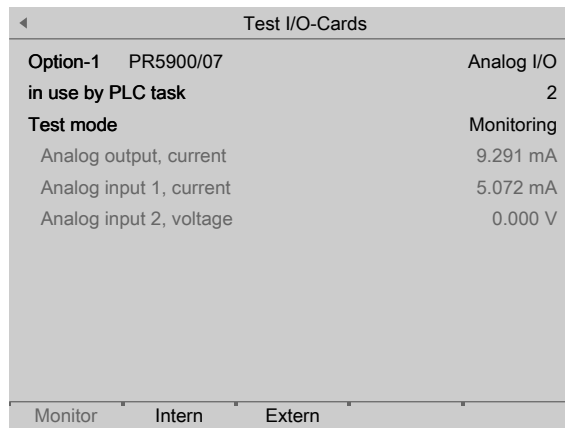

Test mode 1 [Monitoring] is active.

2. Press the [Extern] soft key.

▷ An information window is displayed.

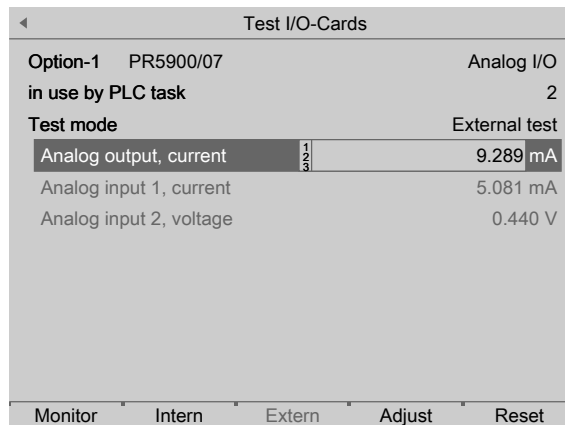

Test mode 3 [External test] is active.

3. Press the [Adjust] soft key.

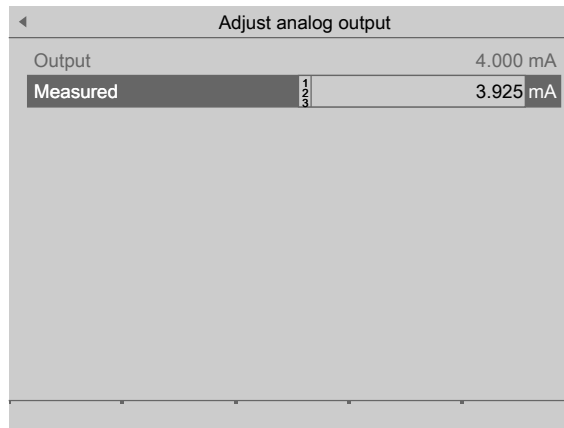

4. Enter and confirm e.g. the value for 4 mA measured by the connected PLC under [Measured].

▷ An information window is displayed for the second value (20 mA).

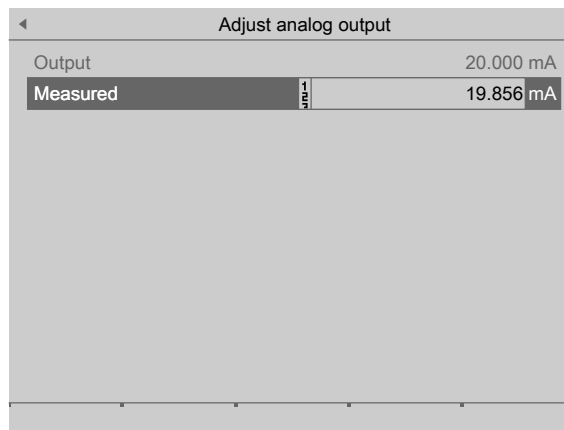

5. Enter and confirm e.g. the value for 20 mA measured by the connected PLC under [Measured].

▷ A prompt window appears.

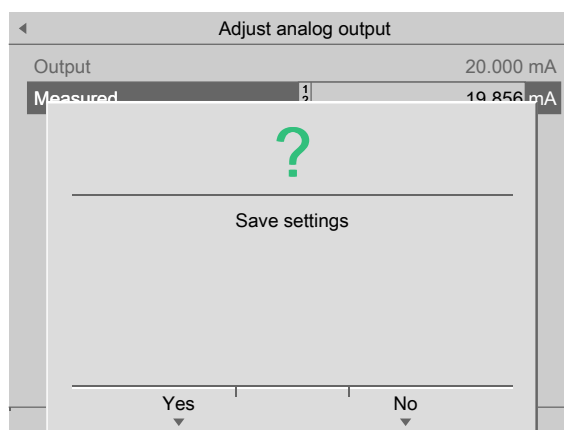

6. Press the [Yes] soft key to save the settings.

Or

7. Press the [Reset] soft key to reset to the factory settings (4 mA and 20 mA).

▷ A prompt window appears.

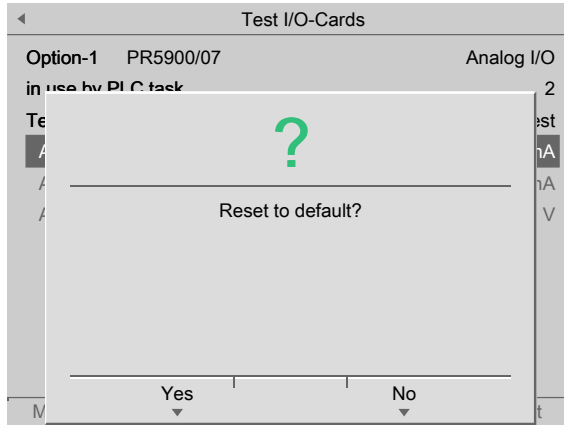

8. Press the [Yes] soft key to reset to the factory settings.
9. Press the **EXIT** key to return to the card test menu.

6.11.3.4 Example: PR 5900/12

Example test (under **I/O cards test**) of a digital input/output card.

Accessible via **MENU** - [Operating] - [System maintenance] - [Test hardware] - [I/O cards test] in this case, card: PR 5900/12.

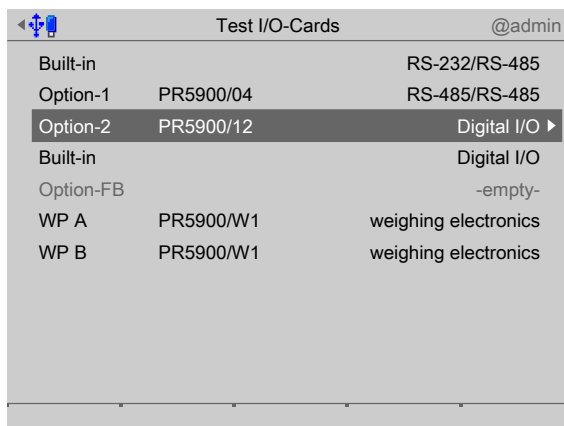

1. Select and confirm the desired card (here: PR 5900/12).
 ▷ An information window is displayed.

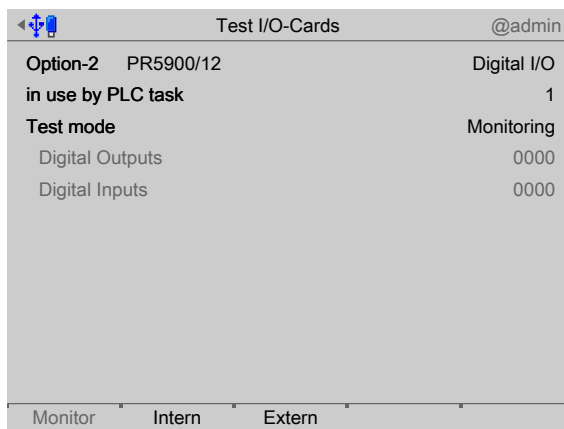

Test mode 1 [Monitoring] is active.

The current input and output values from the PLC (application) are displayed; see Chapter [6.11.3.1](#).

Note:

If the option is not used by the application, test mode 3 is active and the values cannot be changed.

2. Press the [Intern] soft key.
3. Enter the input values using the keyboard and confirm.

Input: 0 and 1 (e.g.: 1111; 0010)

▷ An information window is displayed.

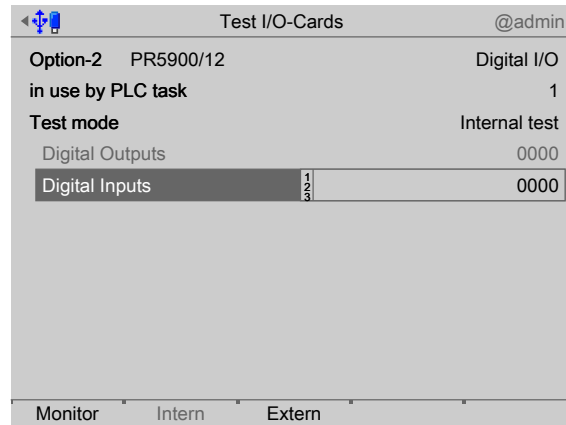

Test mode 2 [Internal test] is active.

The inputs are simulated to test the functionality of the PLC (application); see Chapter [6.11.3.1](#).

4. Press the [Extern] soft key.
5. Enter the output values using the keyboard and confirm.

Input: 0 and 1 (e.g.: 1111; 0010)

▷ An information window is displayed.

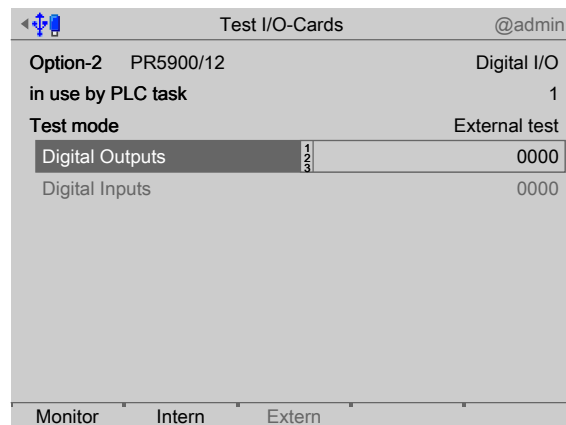

Test mode 3 [External test] is active.

The physical inputs and outputs (hardware) are tested without the involvement of the PLC (application), see Chapter [6.11.3.1](#).

6. Press the **EXIT** key to return to the card test menu.

7 ModBus protocol

7.1 General description

The ModBus protocol implemented in the device enables rapid, simple, and reliable communication between a PC or SPS and up to a maximum of 127 devices.

The ModBus protocol allows access to all data published in the SPM table of the relevant application.

Implementation:

The functions 1, 2, 3, 4, 5, 6, 8, 15, and 16 are supported.

Bits can only be read or set individually or in groups of eight.

8 Fieldbus interface

8.1 General notes

The PR 5900 can be turned into a field bus slave by inserting a field bus interface card in Option-FB.

This enables one or more devices to be included under a communication master (e.g., Siemens S7 ProfiBus).

Up to four weighing points per device may be addressed via the field bus interface.

The update rate is 50 ms.

Configuration of the interface is carried out in the device under [System setup] - [Fieldbus parameters], see Chapter 4.6.

The field bus exchanges its data cyclically with each slave. That means: In each cycle, the entire data range is written and read, even if there are no changes to the data content.

There are two different access protocols.

Scale protocol

8 bytes for simple scale functions: Read weights and states.

SPM protocol

This wider interface can be used to access all data described in the SPM table of the respective application.

Concept definition

Term/Abbreviation	Description
Master	Field bus master, usually an SPS
Slave	Field bus device
MOSI	Master Out Slave In = data is written from the SPS via the field bus to the device.
MISO	Master In Slave Out = data is returned from the device via the field bus to the SPS.

8.2 Scale protocol

If scales A and B are configured, the interface works with a 16-byte (2 x 8) write window and a 16-byte (2 x 8) read window. The windows are assigned to the weighing points.

Note:

All fieldbus data is only valid, if 'Read_Value_Selected' has been reflected.

8.2.1 Data exchange range

Overview

Byte	0, 1, 2, 3	4	5	6, 7
MOSI	Write data	Read_Value_Select	Write_Value_Select	Control bits (control bits)
MISO	Read data	Read_Value_Selected	Status bits (status bits)	Status bits (status bits)

Write window (MOSI)

Byte	Field	Description
0	Write data (MSB)	Contains the data to be written, e.g., analog output.
1	Write data	
2	Write data	
3	Write data (LSB)	
4	Read_Value_Select	Selects the function for reading data.
5	Write_Value_Select	Selects the function for writing data.
6	free free free free free free free free free	In direct access, control bits are independent of the write or read request. "Free" bits are application specific.
7	free free Res Power Res Test Set Test Res Tare Set Tare Set Zero	
	Bit 7 Bit 6 Bit 5 Bit 4 Bit 3 Bit 2 Bit 1 Bit 0	

Field	Size	Function
Write data	4 bytes	Data to be written as a binary 32-bit value with plus or minus sign. Data type: DINT
Read_Value_Select	1 byte	Function for selecting the read request
Write_Value_Select	1 byte	Function for selecting the write request
ResPower	1 bit	PowerFail is reset.
ResTest	1 bit	The test operating mode is finished.
SetTest	1 bit	The test operating mode is started. Now the test value can be read out by reading the gross weight.
ResTare	1 bit	Tare is reset.
SetTare	1 bit	The weighing point is tared.
SetZero	1 bit	The weighing point is set to zero.

Field	Size	Function
Test_Active	1 bit	The device executes the ADC test. The read weight value is not the gross value, but the test value.
OutOfRange	1 bit	Below zero or above max. (FSD).
Standstill	1 bit	The scale is stable.
InsideZSR	1 bit	The gross weight value is within the zero setting range.
CenterZero	1 bit	The weight value is within center zero (0 ± 0.25 d).
BelowZero	1 bit	The weight value is negative (gross < 0 d).
Overload	1 bit	The weight value has exceeded the measuring range. No valid weight data is specified (gross > FSD+overload).
AboveMax	1 bit	The weight value has exceeded the max. (FSD), but is still within max. + permissible overload (gross \leq FSD+overload).
ADUError	1 bit	AD conversion error, see Chapter 8.2.5.1 .

8.2.2 Reading and writing data with function numbers

8.2.2.1 Reading data

Procedure:

1. Write the function number as **Read_Value_Select** in byte 4 of the write window (e.g., 9 = net weight).
2. Wait until **Read_Value_Selected** in byte 4 of the read window is equal to **Read_Value_Select** of the write window.
 - ▷ The requested value is available in bytes 0-3.

Action of the master	Slave reaction
Write function number to Read_Value_Select .	
	Write requested data in Read_Data (bytes 0-3).
	Copy Read_Value_Select to Read_Value_Selected .
Wait until Read_Value_Selected = Read_Value_Select .	
Read requested data in Read_Data (bytes 0-3).	

8.2.2.2 Writing data

Procedure:

1. Wait until **Write_Active** = 0 in the read window (slave is ready to receive new data).
2. Write value in bytes 0-3 of the write window.

3. Write the function number as **Write_Value_Select** in byte 5 of the write window (e.g., "Basic" application: 190 = analog output 1).
4. Wait until **Write_Active** = 1 in the read window.
5. Write 0 in byte 5 (**Write_Value_Select**).
 - ▷ **Write_Active** is reset.

Action of the master	Slave reaction
Write value in Write_Data (bytes 0-3).	
Write function number to Write_Value_Select .	
	Read data from Write_Data (bytes 0-3).
	Set the Write_Active bit.
Wait until Write_Active has been set.	
Write 0 in Write_Value_Select .	
	Reset the Write_Active bit.

8.2.2.3 Writing bits

In addition to the control bits in bytes 6/7, further bits can be set and, if necessary, reset directly with **Write_Value_Select**.

To set bits 80 to 127, the corresponding function number is written to **Write_Value_Select** (see Chapter [8.2.5](#)).

To reset bits 80 to 89, the corresponding function number +128 (208 to 217) is written to **Write_Value_Select**.

Action of the master	Slave reaction
Writing the bit address as a function number to Write_Value_Select .	
	The bit from Write_Value_Select is set and the corresponding function carried out.
	Set the Write_Active bit.
Wait until Write_Active has been set.	
Write 0 in Write_Value_Select .	
	Reset the Write_Active bit.

8.2.2.4 Reading bits

Reading individual bits which are not contained directly in the read window is only possible with a corresponding function number and the data in **Read_Data** (Byte 0-3) of the read window. In those bytes, the bits must be evaluated individually.

The procedure is the same as that described in Chapter [8.2.2.1](#).

8.2.3 Reading and writing bits directly

For reading status bits and for writing direct control bits, no procedure is required. The general status bits are always provided and need not be requested. The direct control bits are also available continuously.

8.2.3.1 Reading status bit

The status bits in bytes 5-7 of the read window are always available and can be read directly by the master.

8.2.3.2 Writing control bits

Some device functions can be executed by setting bits directly in bytes 6 and 7 (control bytes) of the write window.

Action of the master	Slave reaction
Set bits in the control byte .	Function is executed.
Reset bits in the control byte .	

8.2.4 Waiting for the result of the action

When an action requiring more time is started, the end of execution can also be waited for.

Action of the master	Slave reaction
For setting bits, see Chapter 8.2.2.3 or 8.2.3.2 .	Set the CmdBusy bit.
	Function is executed.
	In the event of an error: Set the CmdError bit and the LastError byte.
	If the function is executed or timeout: reset the CmdBusy bit.
Wait until CmdBusy = 0.	
Check the CmdError bit.	
If CmdError is set: Evaluate the LastError (for function number 4, see Chapter 8.2.5.4)	
Set the ResetError bit (for function number 121, see Chapter 8.2.5.10).	
	The ResetError bit is reset.
	The CmdError bit is reset.

8.2.5 Function numbers

Function numbers are written to MOSI by the master (SPS) and reflected in MISO by the PR 5900.

Depending on the installed application, additional function numbers with application data may be available (see application manuals).

- Function number 1: scale status (read), see Chapter [8.2.5.1](#)
- Function number 4: calibration information, error byte (read), see Chapter [8.2.5.4](#)
- Function number 5: device type and software version (read), see Chapter [8.2.5.5](#)
- Function number 6: serial number of the weighing point (read), see Chapter [8.2.5.6](#)
- Function numbers 8 to 15: weight data (read), see Chapter [8.2.5.8](#)
- Function numbers 80 to 89: state-controlled action bits (write), see Chapter [8.2.5.9](#)
- Function numbers 112 to 119; 121: transition-controlled action bits (write), see Chapter [8.2.5.10](#)

8.2.5.1 Function number 1: scale status (read)

Dynamic status

	Bit 7	Bit 6	Bit 5	Bit 4	Bit 3	Bit 2	Bit 1	Bit 0
Byte 0	OutOf Range	Standstill	Inside ZSR	Center Zero	Below Zero	Overload	Above Max	ADU Error
Byte 1				E9	E6	E1	E3	E7
Byte 2						PowerFail	Action Active	CmdError
Byte 3						Tare Active	Cal Changed	Test Active

Note:

Byte 0 corresponds to byte 7 in the output area. Weight error in byte 1, see table in Chapter [9](#)).

Field	Function
ADUError	AD conversion error (OR function of bits E1, E3, E7).
AboveMax	The weight value has exceeded the Max (FSD), but is still within Max + permissible overload ($\text{gross} \leq \text{FSD} + \text{overload}$).
Overload	The weight value has exceeded the measuring range. No valid weight data is specified ($\text{gross} > \text{FSD} + \text{overload}$); error 2 .
BelowZero	The weight value is negative ($\text{gross} < 0$).
CenterZero	The weight value is within center zero ($0 \pm 0.25 \text{ d}$)
InsideZSR	The gross weight value is within the zero setting range.
Standstill	The scale is stable.
OutOfRange	Below zero or above max. (FSD).
E7	The measuring signal is negative (inverse conversion); error 7
E6	Sense voltage not present or too low; error 6

Field	Function
E3	The measuring signal is >36 mV (no end of conversion); error 3
E1	Arithmetic error (overflow); error 1
E9	No communication with xBPI scale; error 9
CmdError	Error during execution (CmdError); e.g., the "taring" operation is not processed, because the scale is not at a standstill. The error is stored in LastError (function number 4). The bit is reset with the ResetError bit (function number 121, see Chapter 8.2.5.10).
ActionActive	The device is busy executing a function (e.g., waiting for downtime for taring).
PowerFail	Power failure; is always set after power on. The PowerFail bit is reset with the ResetPWF bit (function number 85, see Chapter 8.2.5.9) "Reset power failure".
Test_Active	The device executes the ADC test. The read weight value is not the gross value, but the test value.
Cal_Changed	The device has been calibrated. When this bit is 1, the weighing parameters (EXPO/UNIT/STEP) must be read again. Set after "Power on" and reset after reading the FSD (Full scale deflection).
Tare_Active	The scale has been tared.

8.2.5.2 Function number 2: For internal use only.

8.2.5.3 Function number 3: For internal use only.

8.2.5.4 Function number 4: calibration information, error byte (read)

Byte	Description
0: EXPO	One byte for the position of the decimal point; content in decimal form: 0 to 255.
	0 = 000000
	1 = 00000.0
	2 = 0000.00
	3 = 000.000
	4 = 00.0000
	5 = 0.00000
1: UNIT	One byte for the weight unit; content in decimal form: 0 to 255
	1 = mg (milligrams)
	2 = g (grams)
	3 = kg (kilograms)

Byte	Description
	4 = t (tons)
	5 = lb (pounds)
	9 = oz (ounces)
2: STEP	One byte for the scale interval; content in decimal form: 0 to 255
	1 = scale interval "1"
	2 = scale interval "2"
	5 = scale interval "5"
	10 = scale interval "10"
	20 = scale interval "20"
	50 = scale interval "50"
3: LASTERROR	Last error byte; see also CmdError bit, number of LASTERROR:
	8 = no standstill was achieved (e.g., when taring).
	13 = zero setting is not possible. The scale has been tared.
	18 = negative weight value when taring and W&M mode on.
	147 = no zero setting; weight not within zero setting range.
	255 = general command error
Note:	
Other error nos are possible.	

8.2.5.5 Function number 5: device type and software version (read)

	Bit 7	Bit 6	Bit 5	Bit 4	Bit 3	Bit 2	Bit 1	Bit 0
Byte 0	TYPE MSB							
Byte 1	TYPE LSB							
Byte 2	MAINVERSION							
Byte 3	SUBVERSION							

e.g.: PR 5900 Rel. 1.00 = 59000100_{hex}

8.2.5.6 Function number 6: serial number of the weighing point (read)

	Bit 7	Bit 6	Bit 5	Bit 4	Bit 3	Bit 2	Bit 1	Bit 0
Byte 0	Serial number MSB							
Byte 1	Serial number							
Byte 2	Serial number							
Byte 3	Serial number LSB							

e.g.: 148388723 = 08D83B73_{hex}

8.2.5.7 Function number 7: For internal use only.**8.2.5.8 Function number 8 to 15: weight data (read)**

The gross, net, and tare weight are stored as a DINT fix point. The real data value is derived from DINT and EXPO as follows:

$$\text{Value}_{\text{Real}} = \text{reading}_{\text{DINT}} \times 10^{(-\text{EXPO})}$$

Function number 8	Current gross value	
Function number 9	Current net value, if tared; otherwise gross	
Function number 10	Current tare value, if tared; otherwise 0	
Function number 11	Only if supported by the application: current gross/net weight selected. Otherwise: Reserved for internal use.	
Function number 12	Current gross value in internal resolution (1/100d)	
Function number 13	Current tare value in internal resolution (1/100d)	
Function number 14	Max (Full scale deflection)	
Function number 15	Min	

8.2.5.9 Function number 80–89: state-controlled action bits (write)**Note:**

For setting bits, see Chapter [8.2.2.3](#).

Only setting and resetting of single bits is possible.

When changing a bit from 0 to 1, the corresponding action starts. After handling the command, the bit must be reset. Application: The master writes cyclically.

The bit is set as **Write_Value_Select** with the specified number (see Chapter [8.2.2.3](#)).

The bit is reset at the specified number +128.

Function number 80	SetZero	Set the gross weight to zero.
Function number 81	SetTare	The weighing point is tared.
Function number 82	ResetTare	Reset tare.
Function number 83	SetTest	Start the ADC test.

Function number 84	ResetTest	Finish the ADC test.
Function number 85	ResetPwf	Reset the PowerFail bit (function number 1; the bit was set after "power on").
Function number 86	SetFixTare	Taring with weight in numerical address e. g. D31 (weighing point A) "Fixtare".
Function number 87	GetFixTare	The current gross weight is copied to the numerical address e. g. D31 (weighing point A).
Function number 89	ResetError	The CmdError error bit is reset.

8.2.5.10 Function number 112–119, 121: transition-controlled action bits (write)

For setting bits, see Chapter [8.2.2.3](#).

As soon as the bit has been set, it is reset internally and the process is carried out; this process is transition-controlled (for one write operation).

The bit is set as **Write_Value_Select** with the specified number (see Chapter [8.2.2.3](#)).

Function number 112	SetZero
Function number 113	SetTare
Function number 114	ResetTare
Function number 115	SetTest
Function number 116	ResetTest
Function number 117	ResetPwf
Function number 118	SetFixTare (function number 86, see Chapter 8.2.5.9).
Function number 119	GetFixTare (function number 87, see Chapter 8.2.5.9).
Function number 121	ResetError

8.2.6 Example: reading the gross weight

Input range (MOSI)

Byte	Value	Description
0		
1		
2		
3		
4	08	Read the gross weight (for function number 8, see Chapter 8.2.5.8)
5		
6		
7		

Output range (MISO)

Byte	Value								Description
0	00								Gross weight - byte 0 (MSB)
1	00								Gross weight - byte 1
2	04								Gross weight - byte 2
3	D2								Gross weight - byte 3 (LSB)
4	08								Gross weight request detected.
5	Write Active	Power Fail							In direct access, status bits are independent of the write or read request.
6	Cmd Busy	Cmd Error				Tare Active	Cal Active	Test Active	
7	OutOf range	Stand- still	Inside ZSR	Center Zero	Below Zero	Over- load	Above Max	ADU Error	
	Bit 7	Bit 6	Bit 5	Bit 4	Bit 3	Bit 2	Bit 1	Bit 0	

The gross value (hex:000004D2 <=> 1234) can be read from bytes 0...3.

Negative values are output in the second complement.

8.2.7 Special note for DeviceNet and EtherNet IP

With these fieldbus types, the sequence of the bytes (only applicable for words and individual bytes) is inverted.

With long words, this problem does not arise due to compensation by the firmware.

Sequence of data bytes 0...3:

Standard sequence		Sequence for DeviceNet and EtherNet-IP	
Byte 0	Read data 0 (MSB)	Byte 0	Read data 3 (LSB)
Byte 1	Read data 1	Byte 1	Read data 2
Byte 2	Read data 2	Byte 2	Read data 1
Byte 3	Read data 3 (LSB)	Byte3	Read data 0 (MSB)

Consequently, the sequence on the PLC side must be changed when using the "DeviceNet" and "EtherNet IP" fieldbus types.

8.3 SPM protocol**8.3.1 Data exchange range****Overview**

Byte	0	1, 2	3	4	5, 6	7	8...
MOSI	rdfun	rdadr	rdlen	wrfun	wradr	wrlen	wrdata...
MISO	rdfun	rdadr	rdlen	wrfun	wradr	wrlen	rddata...

Write window (MOSI)

Field	Size	Function
rdfun	1 byte	Selects the function for reading data. Only read function codes are permitted.
rdaddr	2 bytes (MSB:LSB)	Provides the address for reading.
rdlen	1 byte	Provides the number of elements to be read (bits/bytes/words).
wrfun	1 byte	Selects the function for writing data. Only write function codes are permitted.
wraddr	2 bytes (MSB:LSB)	Provides the address for writing.
wrlen	1 byte	Provides the number of elements to be written (bits/bytes/words).
wrdata	1...FB-Size-8	Contains the data to be written

Read window (MISO)

Field	Size	Function
rdfun	1 byte	rdfun, rdaddr, and rdlen from the write window are mirrored if the data is available in rddata.
rdaddr	2 bytes (MSB:LSB)	
rdlen	1 byte	
wrfun	1 byte	wrfun, wraddr, and wrlen from the write window are mirrored if the data has been written to wrdata.
wraddr	2 bytes (MSB:LSB)	
wrlen	1 byte	
rddata	1...FB-Size-8	rddata contains the read data.

8.3.2 Function numbers

Function numbers are written to MOSI by the master (SPS) and reflected in MISO by the PR 5900.

Number	Function	Mode
0x00	Idle	n.a. (not active)
0x01	Read bits	Once
0x02	Read bytes (8-bit values)	Once
0x04	Read words (16-bit values)	Once
0x08	Read dwords (32-bit values)	Once
0x41	Write bits	Once
0x42	Write bytes (8-bit values)	Once
0x44	Write words (16-bit values)	Once
0x48	Write dwords (32-bit values)	Once
0x81	Read bits	Cyclic

Number	Function	Mode
0x82	Read bytes	Cyclic
0x84	Read words	Cyclic
0x88	Read dwords	Cyclic

"Read bits" enables reading

- of a single bit (rdlen == 1)
 - of several bits
- rdlen and rdadr must be multiples of 8.

The result is the same as when reading the corresponding bytes via "read bytes".

"Write bits" enables writing

- of a single bit (wrlen == 1)
- The bit is set if wrdata <>0
The bit is deleted if wrdata == 0
- of several bits
- wrlen and wradr must be multiples of 8.

The result is the same as when writing the corresponding bytes via "write bytes".

8.3.3 Error code

If an error is detected, an error code will be written to MISO.rdfun or MISO.wrfun.

The error can only be reset by entering a "0" in MOSI.rdfun or MOSI.wrfun.

Code	Error
0xFF	Unknown function number
0xFE	Invalid ..addr/..len <ul style="list-style-type: none"> - SPM range exceeded - Invalid ..addr/..len combination for bit access - Access to certain areas refused.
0xFD	Invalid ..len Fieldbus size rddata/wrdata exceeded
0xFC	Function number for the block (e.g. MO-SI.rdfun := 0x41, 0x41 has been written) invalid

8.3.4 Data exchange modes

The following flow charts illustrate the actions of the master and slave during data exchange.

"Once" mode

Write once

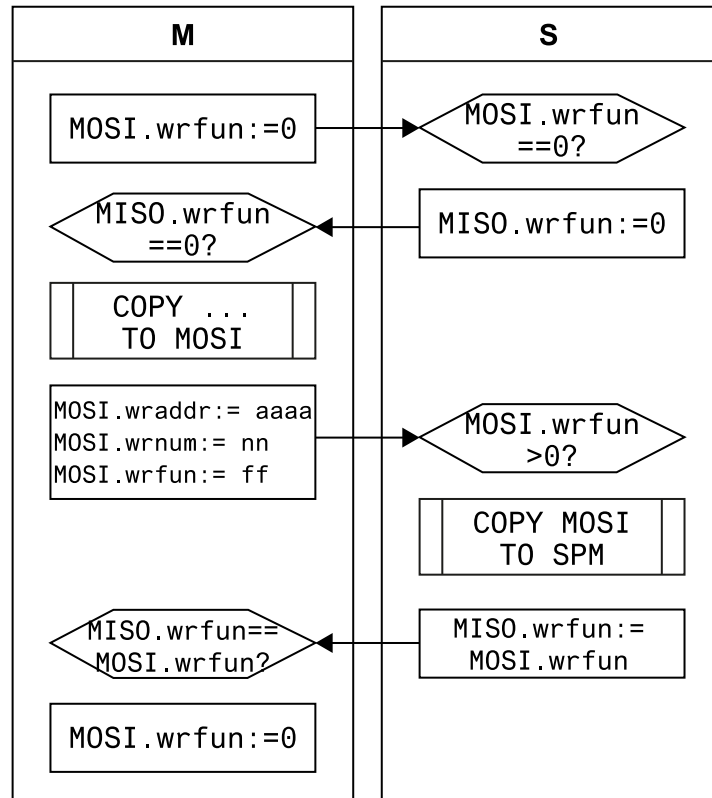

M = Master
S = Slave

Read once

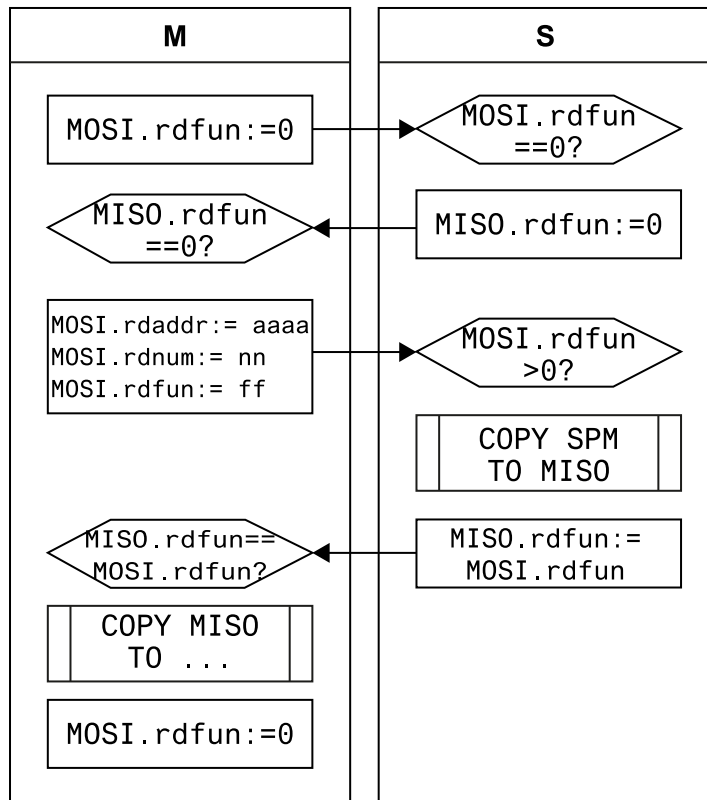

M = Master
S = Slave

A single read or write action is triggered. This ensures that the current data is synchronous once the handshake has been completed.

"Cyclical reading" mode

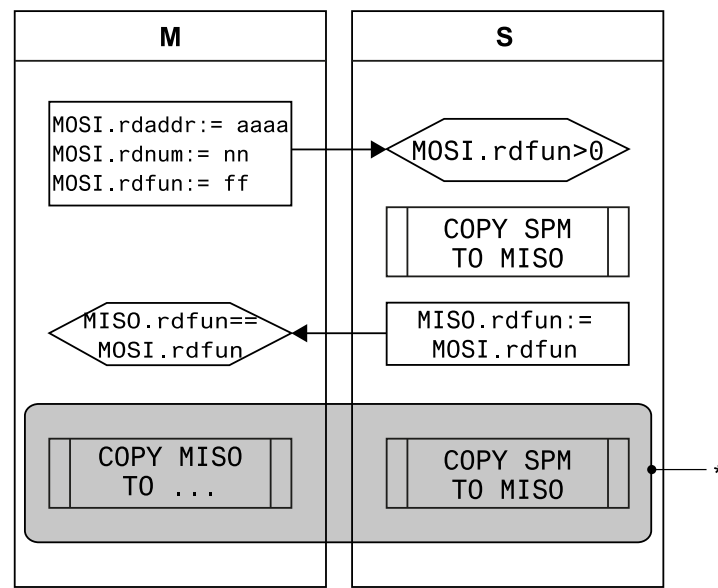

M = Master
 S = Slave
 * = constantly asynchronous

Cyclical modes are only permitted for use with read data. There is no synchronization between master and slave.

Handshake error

Master	Slave
...	...
	Recognizes an error
	Sets MISO.xxfun := error code
Recognizes MISO.xxfun == error code	Waits for MOSI.xxfun == 0
Sets MOSI.xxfun := 0	
	Recognizes MOSI.xxfun == 0
	Sets MISO.xxfun := 0

9 Error messages

9.1 Error messages measuring circuit

The internal weighing electronics can generate error messages, which are shown on the weight display.

Display	Error and possible cause
Arith. error	Internal arithmetic overflow: <ul style="list-style-type: none"> - Incorrect calibration values e.g. due to incorrect calibration.
Overload	The measuring signal is higher than Max + (x d): <ul style="list-style-type: none"> - Wrong setting. - Too much weight on the scale.
No signal	Measuring input open: <ul style="list-style-type: none"> - The measuring signal is higher than the permissible range of 36 mV. - Measuring cable is interrupted (cable break detection). - Other hardware defect.
Value exceeds display	No display of weight values: <ul style="list-style-type: none"> - Example: 30,000 kg scale and weight unit toggle to mg. - > 9999000 mg (= 9,999 kg) this error message appears.
No sense voltage	No sense voltage: <ul style="list-style-type: none"> - Load cells not connected. - Sense line or supply line is interrupted. - Wrong polarity or sense voltage is low.
Negative input	Negative measuring signal (< -0.1mV/V): <ul style="list-style-type: none"> - Wrong polarity of load cell signal. - Wrong polarity of load cell supply voltage.
Incompatible units	Incompatible weight units: <ul style="list-style-type: none"> - Incorrect calibration values e.g. due to incorrect calibration.
No values from scale	Internal weighing point: The measuring signal is higher than the permissible range of 36 mV. Cannot read weight values from ADC (analog-digital converter). <ul style="list-style-type: none"> - Error in weighing electronics board. - Defective load cell. - Cable break.
Test active	No gross weight value: <ul style="list-style-type: none"> - Test has not yet ended.
Wrong serial number Only appears when CAL switch is closed.	<ul style="list-style-type: none"> - Weighing electronics board has been changed after calibration. - Device is not calibrated.

Display	Error and possible cause
Read config failed	The saved configuration and calibration data cannot be read. <ul style="list-style-type: none"> - Restore the data saved in a backup (in menu [Operating] - [System maintenance] - [Restore] - [SD card]) to the device (see Chapter 6.2.1). - First set the weighing electronics (e.g. [internal weighing point]) to [not assigned], save, and then reassign.
Warmup 123	The device is in the warmup phase, duration approx. 30 s

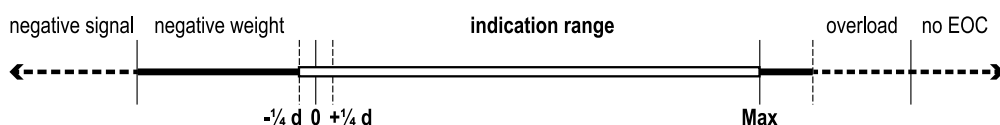

9.2 Error messages for xBPI scales

Display	Error and possible cause
Overload	The measuring signal is higher than $\text{Max} + (x \text{ d})$: <ul style="list-style-type: none"> - Wrong setting. - Too much weight on the scale.
Value exceeds display	No display of weight values: <ul style="list-style-type: none"> - Too many digits have been set.
No weight value	The xBPI scale is not providing any usable weights. <ul style="list-style-type: none"> - Taring process cannot be completed.
Incompatible units	Incompatible weight units: <ul style="list-style-type: none"> - Incorrect calibration values e.g. due to incorrect calibration.
No values from scale	No communication with xBPI scale: <ul style="list-style-type: none"> - Cable break. - Internal scale error. - Scale not connected to power.
Wrong configuration	<ul style="list-style-type: none"> - Tare disabled. - Tare 2 not permitted. - Application tare too large.
Scale not ready	No scale ready for weighing: <ul style="list-style-type: none"> - The device is in the warm-up phase. - The device is in automatic taring mode. - The device was switched on with the scale loaded.
Wrong serial number	Serial number of scale does not match the number set in the device.

Display	Error and possible cause
Read config failed	The saved configuration and calibration data cannot be read. <ul style="list-style-type: none"> - Restore the data saved in a backup (in menu [Operating] - [System maintenance] - [Restore] - [SD card]) to the device (see Chapter 6.2.1). - First set the weighing electronics (e.g. [internal weighing point]) to [not assigned], save, and then reassign.

9.3 Error messages for Pendeo load cells

Display	Error and possible cause
Overload	The measuring signal is higher than Max + (x d): <ul style="list-style-type: none"> - Wrong setting. - Too much weight on the scale.
Value exceeds display	No display of weight values: <ul style="list-style-type: none"> - Too many digits have been set.
Incompatible units	Incompatible weight units: <ul style="list-style-type: none"> - Incorrect calibration values e.g. due to incorrect calibration.
No values from scale	No communication with Pendeo load cell: <ul style="list-style-type: none"> - Cable break. - Internal scale error. - Scale not connected to power.
Wrong configuration	Number of load cells does not match the configuration.
Scale not ready	No scale ready for weighing: <ul style="list-style-type: none"> - At least 1 load cell gives an error status or is defective (no communication)
Wrong serial number	Serial number of scale does not match the number set in the device.
Warmup 123	The load cells are in the warmup phase, duration approx. 30 s.
Read config failed	The saved configuration and calibration data cannot be read. <ul style="list-style-type: none"> - Restore the data saved in a backup (in the menu [System maintenance] - [Restore] - [SD card]) to the device (see Chapter 6.2.1). - First set the weighing electronics (e.g. [internal weighing point]) to [not assigned], save, and then reassign.

9.4 Error messages at PR-Net weighing point

Display	Error and possible cause	Remote display
Wrong configuration	No IP address or no host name available.	Error 13

9.5 Error messages at "Mettler-Scale" weighing point

Display	Error and possible cause	Remote display
Arith. error	Internal arithmetic overflow: - Parameters/calibration values do not match those of the Mettler-Scale.	Error 1

9.6 Warnings when assigning a weighing point

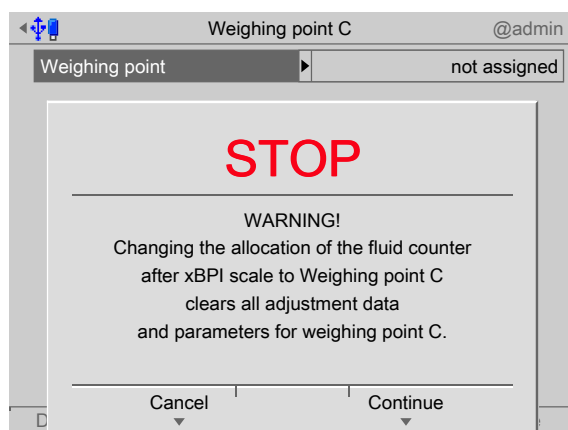

After a weighing point has been assigned, it is set to the default values and saved. This message appears if a weighing point is set to [not assigned].

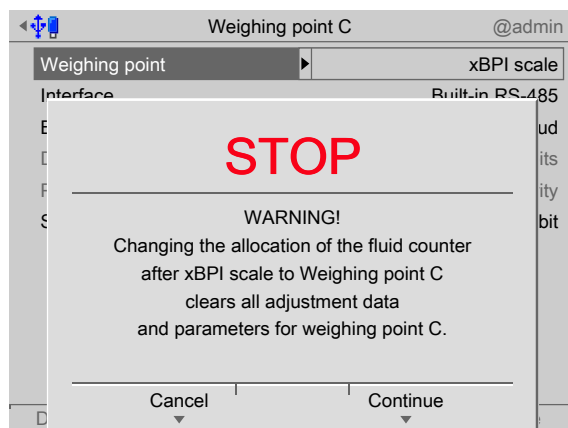

This message appears if this weighing point is assigned to a different scale.

9.7 Error messages during calibration

- Determining the maximum capacity (MAX), see Chapter 9.7.1.

- Determining the scale interval, see Chapter 9.7.2.
- Determining the dead load, see Chapter 9.7.3.
- Calibrating with weight, see Chapter 9.7.4.

9.7.1 Determine MAX (maximum capacity)



Example display for the following error messages.

Error display	Possible causes
Set Max failed. > phys. Max.	The maximum capacity of the scale can be increased retroactively. This message appears when the measurement signal for the given maximum capacity would exceed the permissible input voltage.
Set Max failed. below calibration weight	The maximum capacity of the scale can be increased retroactively. When the capacity is reduced, however, a message appears when the new maximum capacity falls below the calibration weight ("calibrated at").
Set Max failed. not enough d	This message is displayed if the selected resolution is too low, e.g., 5 kg.
Set Max failed. too many d	This message is displayed if the selected resolution is so high that less than 0.8 internal counts per scale interval (d) are available.
Set Max failed. Max does not correspond to a multiple of the scale interval.	This message appears if the maximum capacity [Max] of the scale range (weighing range) is not an integer multiple of the scale interval (1 d).
Set Max failed. The weight cannot be adapted to the scale.	No matching of the weight units, e.g. subsequent changing from kg to mg for [Max].
Set Max failed. not enough $\mu\text{V}/\text{d}$ for verifiable scale	This message appears if the selected resolution is so high that less than $0.8 \mu\text{V}/\text{e}$ are available when use in legal metrology as per OIML/NSC has been selected.

9.7.2 Determining the scale interval



This message appears if the maximum capacity [Max] of the scale range is not an integer multiple of the scale interval.

9.7.3 Determining the dead load



Example display for the following error messages.

Error display	Possible cause
Set dead load failed. > phys. Max.	This message is displayed when the dead load entered in mV/V plus scale interval in mV/V is higher than 3 mV/V (= 36 mV).
Set dead load failed. No standstill	This message appears if the scale is not stable. Remedy: - Check the mechanical function of the scale. - Adapt the filter setting; reduce the resolution. - Adapt the standstill conditions.
Set dead load failed. Dead load <-0.1 mV/V	This message appears if the measurement signal is negative when determining the dead load with [by load]. Cause: Load cells connected with the wrong polarity or faulty.

Error display	Possible cause
Set dead load failed. Arithmetic error	This message appears if the dead load entered in mV/V is higher than 5 mV/V.

9.7.4 Calibrating with weight



Example display for the following error messages.

Error display	Possible cause
Set SPAN failed. No standstill	This message appears if the scale is not stable. Remedy: - Check the mechanical function of the scale. - Adapt the filter setting; reduce the resolution. - Adapt the standstill conditions.
Set SPAN failed. Current load is below dead load.	This message appears if the load has been removed from the scale rather than added.
Set SPAN failed. Weight >Max	This message appears when an attempt is made to calibrate the scale with a weight heavier than the [Max].

9.8 Error status in "LAST_ERROR"

An error occurs in the LAST_ERROR variable with actions such as SET_ZERO and SET_TARE.

Possible error numbers are:

Error no.	Cause
0	"OK" ok
1	"no wpt" The defined weighing point is not available.
2	The weighing point is occupied.
3	"not tared" Can't get TARE or NET if not tared
4	Incorrect weight unit

Error no.	Cause
5	"range error" Weight range error
6	Test is active, no weight values.
7	Calibration is active, no weight values.
8	Scale is not at a standstill.
9	"is reactor"
10	No weighing electronics have been assigned.
11	The scale is not in batching mode.
12	The weighing point is not reserved.
13	Taring is active.
14	The weighing point is not being tested.
15	Weight not permissible in legal metrology (<0 or >Max).
16	Weight error
17	The scale is not ready.
18	Taring below zero is not possible.
101	The scale has rejected the command as incorrect.
102	Time limit for sending a command to the scale exceeded.

10 Printouts

10.1 Configuration printout

```
Configuration of PR5900
=====
Revision 01      :      2001-01-01
Production number : 1208-270035-900006
printed         :10/17/2012 11:21:43
Firmware        :Rel 00.02.00.150088
                2012-10-16 14:05
Basic           : Rel 01.00.06.5208
                2012-10-16 12:35
BIOS            :Rel 00.02.00.149997
                2012-10-16 09:52
Board number    :      354942727
```

```
HW options
=====
Option-1 PR5900/07      Analog E/A
Revision 01           : 2012-08-03
Production number    : 1208-270040-900002
Option-2 PR5900/04      RS-485/RS-485
Revision 01           :      2012-08-03
Production number    : 1208-270039-900005
Option-FBPR1721/51     ProfiBus DP
WP A PR5900/W1 Weighing electronics
Revision 01           :      2012-08-21
Production number    : 1208-470044-900006
WP B PR5900/W1 Weighing electronics
Revision 01           :      2012-08-30
Production number    : 1208-470044-900014
```

```
Fieldbus parameters
=====
Fieldbus protocol   :      ProfiBus DP V1
Card settings:not yet configured
```

```
PR1721/51 ProfiBus DP version
=====
Fieldbus SW version :      02.0E
Module SW version   :      02.0E
Module serial number :      2685866899
```

```

Operating parameters
=====
Operating
-----
Display language   : (EN)           English
USB Keyboard layout: German         QWERTZ
Screensaver       :                after 10 minutes
Keyclick sound    :                no key click
Cold start with STOP+:            immediately
Programming
-----
Software download:                    enabled
Label/Lang:                          enabled
Operational keys
-----
Keys require logged in :                off
Tare key               : set tare / reset tare
Zero key               : only when not tared
F1 key                 : Change language
F2 key                 : Change user

```

```

General devices
=====
Remote display      : not assigned
ModBus-RTU master  : not assigned
PC via EW-Com      : not assigned
Printer             : Network printer
Printer type       : Generic PCL5
IP address         : 172.24.19.6

```

```

Additional application devices
=====
Ticket printer     : not assigned
Printer 2          : not assigned

```

```

Network settings
=====
HW address         : 00:90:6C:27:FF:07
Host name          : PR5900-27FF07
use DHCP           : yes
VNC client         : 255.255.255.255

```

License settings

```
=====
Board number      :          354942727
OPC server license :          9268010
Dosing license    :          6651793
Alibi license     :          7803550
Application license:          4886130
Developer license
```

Weighing point A: Int. weigh. point

```
=====
Serial number      :          408966395
Last change       : 2012-10-09 08:45:49
Calibration check number: 0093444057
Max               :          3000.0 g
                  30000 d
Scale interval    :          0.1 g
Dead load at     :          +0.040416 mV/V
                  102.983 g
Max at           :          +1.177344 mV/V
                  3000.000 g
calibrated at    :          2516.5 g
                  +0.987596 mV/V
Sensitivity      :          98.11 cnt/d
                  0.470938 uV/d
```

Units

```
-----
Number of units:  1 weight unit
```

Parameters

```
-----
Settings locked   :          off
W&M              :          none
Measurement time  :          160 ms
Digital filter    :          no filter
Ext. LC supply    : below or equal 8 V
Standstill time   :          0.50 s
Standstill range  :          1.00 d
Tare timeout      :          2.5 s
Zerose range      :          50.00 d
Zero track        :          No
Overload          :          9 d
Minimum weight    :          20 d
Range mode        :          single range
```

```

Weigh. point B: Intern. weigh. point
=====
Serial number      :          409751827
Last change       :          --
Calibration check number:      --
Max               :          3000 kg
                  :          3000 d
Scale interval    :          1 kg
Dead load at     :          +0.000000 mV/V
Max at           :          +1.000000 mV/V
not calibrated
Sensitivity       :          833.33 cnt/d
                  :          4.000000 uV/d

Units
-----
Number of units:  1 weight unit

Parameters
-----
Settings locked   :          off
W&M              :          none
Measurement time  :          160 ms
Digital filter    :          no filter
Ext. LC supply    : below or equal 8 V
Standstill time  :          0.50 s
Standstill range  :          1.00 d
Tare timeout      :          2.5 s
Zeroseat range   :          50.00 d
Zerotrack        :          No
Overload         :          9 d
Minimum weight   :          20 d
Range mode       :          single range

```

```

Weighing point C:      not assigned
=====

```

```

Weighing point D:      xBPI scale
=====
Weighing point      D :          xBPI scale
Settings locked     :          off
W&M                 :          none
Tare timeout        :          2.0 s
Serial number       :          0
SBN address         :          0

```

10.2 Test printout

```

Printer test pattern
=====
      0   1   1   2   2   3   3   4
1234567890123456789012345678901234567890
-- ascii --
!"#$%&'()*+,-./0123456789:;<=>?
@ABCDEFGHIJKLMNPOQRSTUVWXYZ[\]^_
`abcdefghijklmnopqrstuvwxyz{|}~
-- latin1 --
¡¢£¥¦§¨ª«¬®¯°±²³´µ¶·¸¹º»¼½¾¿
ÀÁÂÃÄÅÆÇÈÉÊËÌÍÎÏÐÑÒÓÔÕÖ×ØÙÚÛÜÝÞß
àáâãäåæçèéêëìíîïðñòóôõö÷øùúûüýþÿ
-- cyrillic --
ЁЂЃЄЅІЇЈЉЊЋЌЎЃ
АБВГДЕЖЗИЙКЛМНОП
РСТУФХЦЧШЩЪЫЬЭЮЯ
абвгдежзийклмноп
рстуфхцчшщъыьэюя
ёёђѓєѕіїјљњћќџџ
-- hiragana --
ああいうえおおかがきぎく
ぐけげごさざしじすずせぜそぞた
だちちっつづてとどなにぬねのは
ばひびびびふぶぶへべへほぼほまみ
むめもややゆゆよよらりるれろわわ
ゐゑをんづかけ　　ゝゞ　ゝゞ
-- katakana --
=アアイイウウエエオオカガキギク
グケゲコゴサザシジスズセゼソゾタ
ダチチツツツテテトドナニヌネノハ
バパヒビピフブフヘベペホボポマミ
ムメモヤヤユユヨヨラリルレロワワ
キエランヴカケワヰヱヰ　ー　ゝ　ゝ
-- CJK --
一丁巧七上丁ア万丈三上下丌不与丐
丐丑刃专且丕世卅丘丙业丛东丝丞丢
北尙丟邪两严並喪丨亅个丫丩中卂丰
龐龔龔龔龔龔龔龔龔龔龔龔龔龔龔龔龔
龔龔龔龔龔龔龔龔龔龔龔龔龔龔龔龔龔
龔龔龔龔龔龔龔龔龔龔龔龔龔龔龔龔龔
止凶鐘莖マ彡彡彡彡彡彡彡彡

```

1. Test line width and change if necessary.
2. Check line coding and change in printer if necessary.

Note:

Printer may not be able to output all characters.

10.3 Alibi printout

```

-----
Sequence number      :                #000027
Date/time           : 2013-03-01-10:50:29
Serial number       :                408966395
G                   :                A <1550.3 g>
NET                 :                A <1550.3 g>
T                   :                A 0.0 g
PR 5900 ALIBI
-----
Sequence number      :                #000028
Date/time           : 2013-03-01-11:07:08
Serial number       :                408966395
G                   :                A <1550.5 g>
NET                 :                A <1550.5 g>
T                   :                A 0.0 g
PR 5900 ALIBI
-----
Sequence number      :                #000029
Date/time           : 2013-03-01-11:12:44 PM
Serial number       :                408966395
G                   :                A <0.1 g>
NET                 :                A <0.1 g>
T                   :                A 0.0 g
PR 5900 ALIBI
-----
Sequence number      :                #000030
Date/time           : 2013-03-01-11:15:03 PM
Serial number       :                408966395
G                   :                A <1000.2 g>
NET                 :                A <1000.2 g>
T                   :                A 0.0 g
PR 5900 ALIBI
-----
Sequence number      :                #000031
Date/time           : 2013-03-01-11:20:41 PM
Serial number       :                408966395
G                   :                A <2516.6 g>
NET                 :                A <2516.6 g>
T                   :                A 0.0 g
PR 5900 ALIBI
-----
Sequence number      :                #000032
Date/time           : 3/18/2013-14:44:06
Serial number       :                408966395
G                   :                A <-0.4 g>
NET                 :                A <-0.4 g>
T                   :                A 0.0 g
PR 5900 ALIBI
-----

```

Published by
Minebea Intec GmbH | Meiendorfer Strasse 205 A | 22145 Hamburg, Germany
Phone: +49.40.67960.303 | Email: info@minebea-intec.com
www.minebea-intec.com

