

**Installation manual**

**Mini FLEXLOCK mounting kits PR 6043/30N+S, PR 6043/40N+S**

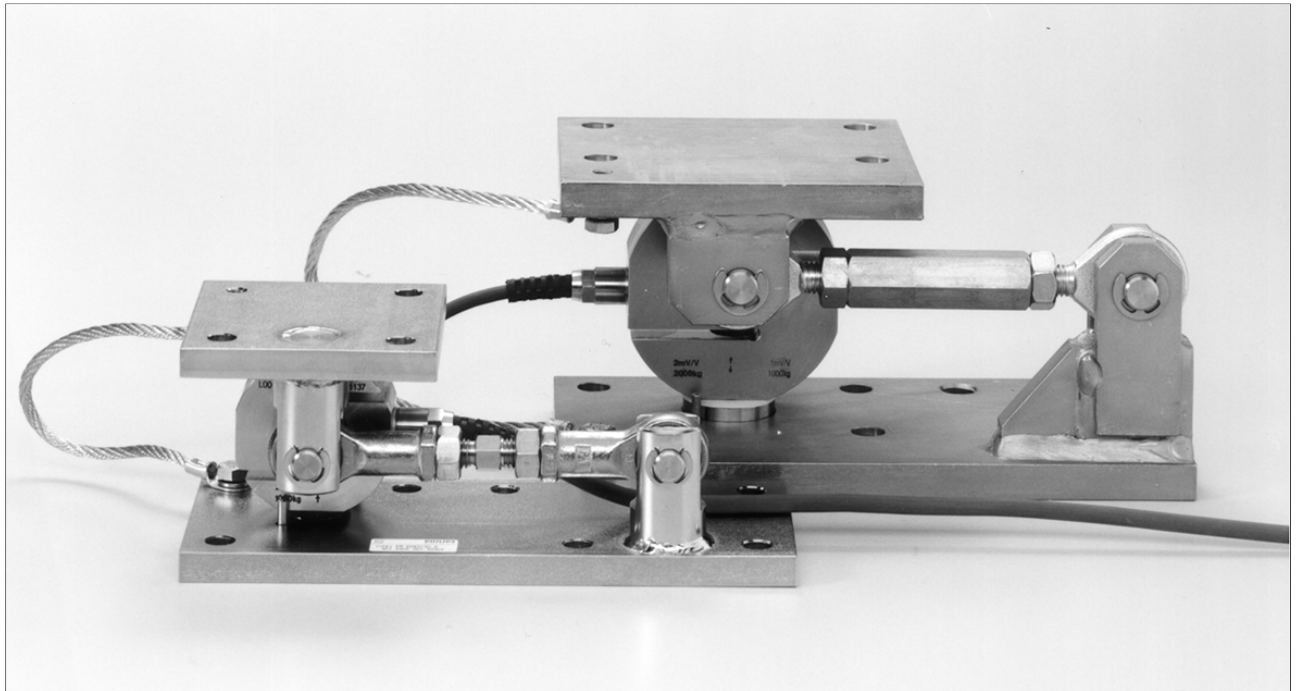

## **Foreword**

### **Must be followed!**

Any information in this document is subject to change without notice and does not represent a commitment on the part of Minebea Intec unless legally prescribed. This product should only be operated/installed by trained and qualified personnel. In correspondence concerning this product, the type, name, and release number/serial number as well as all license numbers relating to the product have to be cited.

### **Note**

This document is partially protected by copyright. It may not be changed or copied, and it may not be used without purchasing or written permission from the copyright owner (Minebea Intec). The use of this product constitutes acceptance by you of the abovementioned provisions.

## Table of contents

<b>1</b>	<b>Introduction</b> .....	<b>2</b>
1.1	Read the manual.....	2
1.2	This is what operating instructions look like.....	2
1.3	This is what lists look like.....	2
1.4	This is what menu items and softkeys look like.....	2
1.5	This is what the safety instructions look like.....	2
1.6	Hotline.....	3
<b>2</b>	<b>Safety instructions</b> .....	<b>4</b>
2.1	General notes.....	4
2.2	Intended use.....	4
2.3	Initial inspection.....	4
2.4	Before operational startup.....	4
<b>3</b>	<b>Recommendations for installation</b> .....	<b>5</b>
3.1	Load cell and constringer arrangement.....	5
3.2	Mounting aid.....	6
3.3	Additional lift-off protection.....	6
<b>4</b>	<b>Specifications</b> .....	<b>8</b>
4.1	Equipment supplied.....	8
4.2	Dimensions.....	9
4.3	Technical data.....	11
<b>5</b>	<b>Installation</b> .....	<b>12</b>
5.1	Prior to mounting.....	12
5.1.1	Preparing the foundation/substructure.....	12
5.2	Tightening torques.....	13
5.3	Assembly.....	13
5.3.1	Safety instructions.....	13
5.3.2	Installing the mounting kit and inserting the load cell.....	14
5.4	Check mounting.....	16
<b>6</b>	<b>Cleaning</b> .....	<b>17</b>
<b>7</b>	<b>Disposal</b> .....	<b>18</b>
<b>8</b>	<b>Spare parts and accessories</b> .....	<b>19</b>
8.1	Replacement parts.....	19
8.2	Accessories.....	19
8.2.1	Load discs.....	19

# 1 Introduction

## 1.1 Read the manual

- Please read this manual carefully and completely before using the product.
- This manual is part of the product. Keep it in a safe and easily accessible location.

## 1.2 This is what operating instructions look like

1. - n. are placed before steps that must be done in sequence.
  - ▶ is placed before a step.
  - ▷ describes the result of a step.

## 1.3 This is what lists look like

- indicates an item in a list.

## 1.4 This is what menu items and softkeys look like

[ ] frame menu items and softkeys.

**Example:**

[Start]- [Applications]- [Excel]

## 1.5 This is what the safety instructions look like

Signal words indicate the severity of the danger involved when measures for preventing hazards are not followed.

### **DANGER**

#### **Warning of personal injury**

DANGER indicates death or severe, irreversible personal injury which will occur if the corresponding safety measures are not observed.

- ▶ Take the corresponding safety precautions.

### **WARNING**

#### **Warning of hazardous area and/or personal injury**

WARNING indicates that death or severe, irreversible injury may occur if appropriate safety measures are not observed.

- ▶ Take the corresponding safety precautions.

### **CAUTION**

#### **Warning of personal injury.**

CAUTION indicates that minor, reversible injury may occur if appropriate safety measures are not observed.

- ▶ Take the corresponding safety precautions.

**NOTICE****Warning of damage to property and/or the environment.**

NOTICE indicates that damage to property and/or the environment may occur if appropriate safety measures are not observed.

- ▶ Take the corresponding safety precautions.
- 

**Note:**

User tips, useful information, and notes.

---

**1.6 Hotline**

Phone: +49.40.67960.444

Fax: +49.40.67960.474

eMail: [help@minebea-intec.com](mailto:help@minebea-intec.com)

## 2 Safety instructions

### 2.1 General notes

#### NOTICE

##### **Warning of damage to property and/or the environment.**

The product was in perfect condition with regard to safety features when it left the factory.

- ▶ To maintain this condition and to ensure safe operation, the user must follow the instructions and observe the warnings in this manual.

### 2.2 Intended use

The mounting kits PR 6043/30N+S, PR 6043/40N+S are intended for weighing tasks, and must only be used as such.

The mounting kits PR 6043/30N+S, PR 6043/40N+S are designed for installing the load cells PR 6241.

The dimensions of all mounting and structural components must be calculated so that sufficient overload capacity is ensured for all loads which may occur while taking the relevant standards into account. In particular, upright weighing objects must be safeguarded against the weighing installation turning over or being shifted, thus eliminating danger to people, animals, or goods even in the case of a break in a load cell or mounting element.

Installation and repair work must only be carried out by expert/qualified personnel.

The mounting kits reflect the state of the art. The manufacturer does not accept any liability for damage caused by third-party system components or due to incorrect use of the product.

### 2.3 Initial inspection

Check the contents of the consignment for completeness. Check the contents visually to determine whether any damage has occurred during transport. If there are grounds for rejection of the goods, a claim must be filed with the carrier immediately. The Minebea Intec sales or service organization must also be notified.

### 2.4 Before operational startup

#### NOTICE

##### **Perform visual inspection.**

- ▶ Before operational startup as well as after storage or transport, inspect the mounting kit visually for signs of mechanical damage.

### 3 Recommendations for installation

#### 3.1 Load cell and constrainer arrangement

Examples:

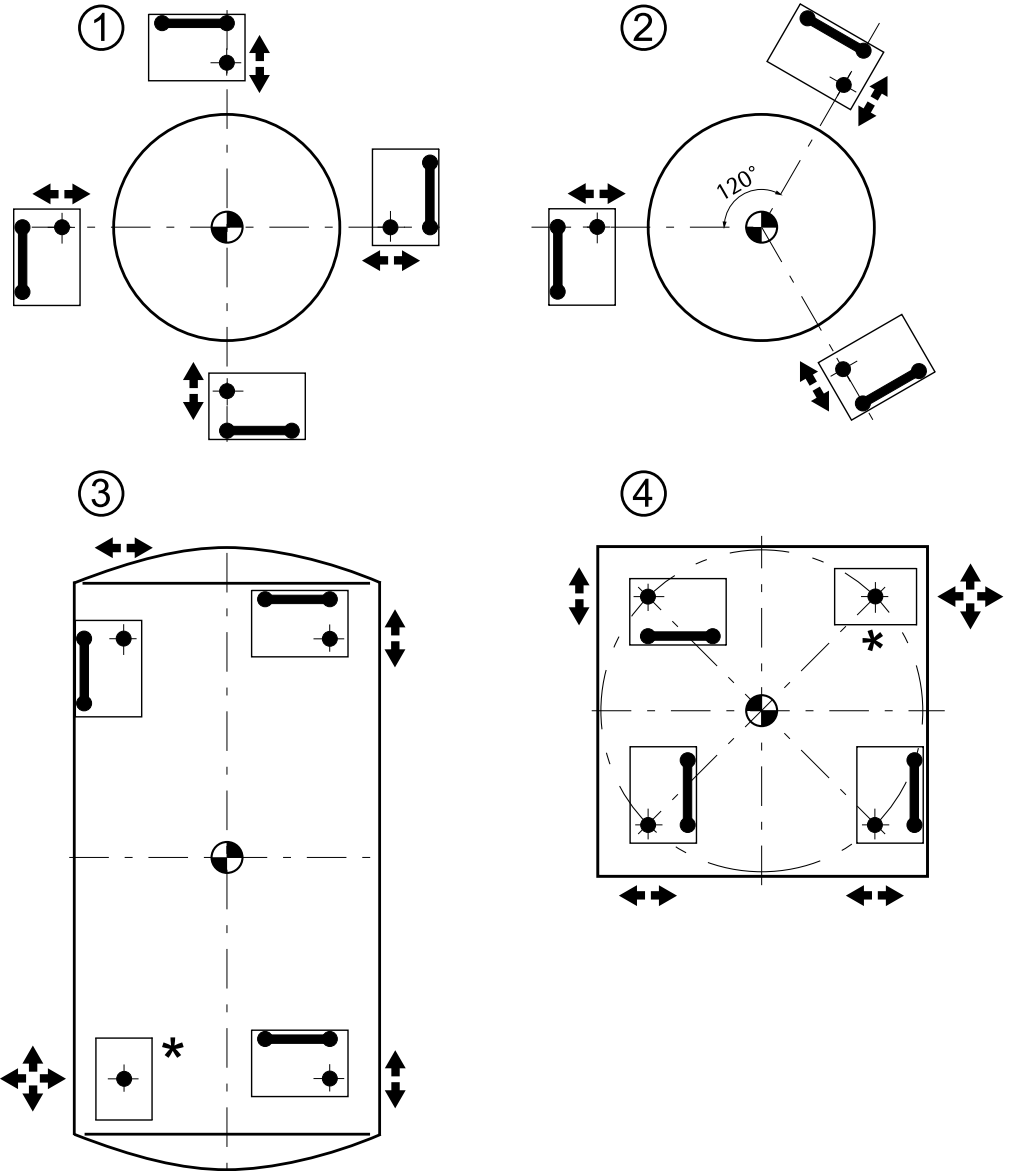

**Key**

*	Do not constrain this position.
	Constrainer
	Load application
	Possible direction of movement

- To ensure the required free moving space of the weighing facility, a maximum of 3 mounting kits with constrainer may be used to constrain a weighing object.

Round containers are the exception (image ① and ②). In this case, any number of constrainers can be installed, provided that they are tangentially aligned.

Special mounting kits are available for weighing points without constrainers. Alternatively, the constrainer can simply be removed.

With elastic constructions, it may be necessary to deviate from this recommendation in order to guarantee the weighing object has sufficient stability.

### 3.2 Mounting aid

Example: PR 6043/30

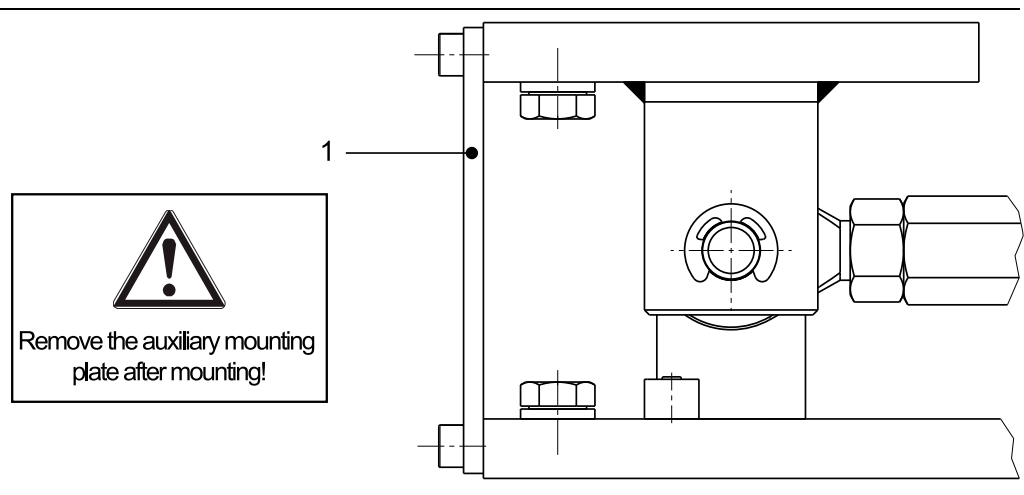

The auxiliary mounting plate (1) is intended to facilitate installation of the mounting kit and load cell.

### 3.3 Additional lift-off protection

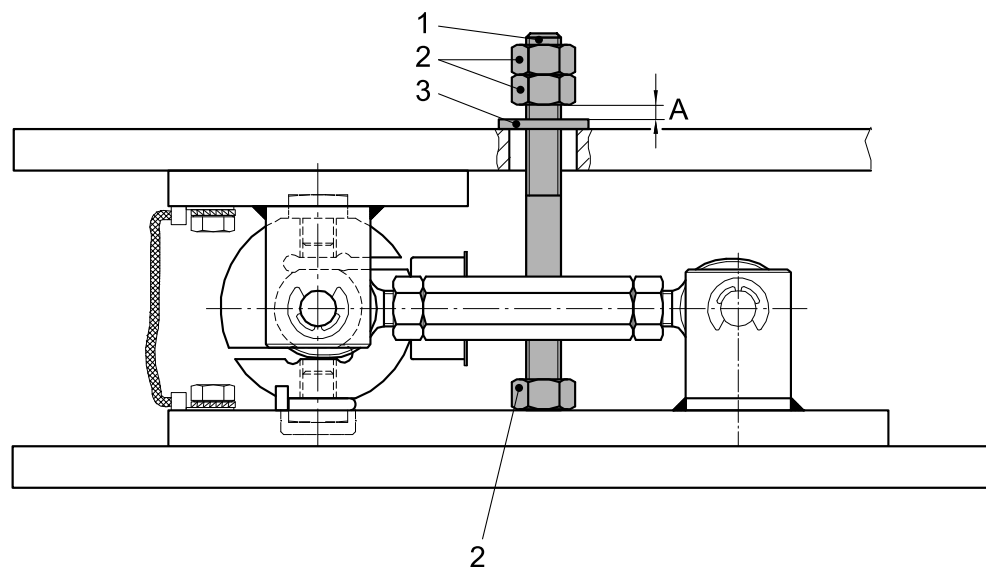

To increase the permissible lifting force for the mounting kits with constrainer, an additional lift-off protection can be installed.

For this purpose, the simplest version requires the following components:

- 1× threaded bar (1)
- 3× nut (2)
- 1× washer (3)

**Assembly:**

- Mount the threaded bar (1) so that it has sufficient free moving space in the drill hole.
- Lock the nuts (2) so that there is a remaining distance A\* from the washer (3).

\* A = 1–2 mm

This distance is essential to avoid force shunts.

The required tightening torques are given in the following table.

<b>Mounting kit</b>	<b>Threaded bar/ nuts</b>	<b>Property class</b>	<b>Tightening tor- que</b>	<b>Perm. overall lift-off force</b>
PR 6043/30	M12	4.6	30 Nm	18 kN
PR 6043/40	M16	4.6	75 Nm	32 kN

## 4 Specifications

### 4.1 Equipment supplied

#### Example: Mounting kit PR 6043/30N+S

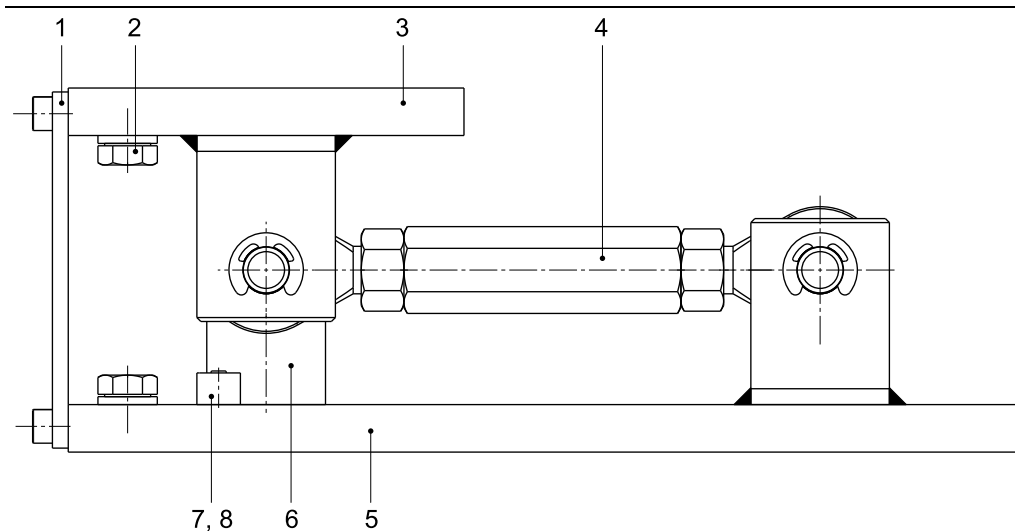

No.	Description
1	Auxiliary mounting plate
2	Screw (2x) and spring washer (2x) for the equipotential bonding cable (supplied with the load cell)
3	Upper plate
4	Constrainer with joint head (2x), screwed joint, nut (2x), bolts (2x), and locking washer (4x)
5	Lower plate
6	Spacer
7	Pin (2x)
8	Included in scope of supplies only with PR 6043/30: Bush (2x); only for load cells PR 6241/12...52
The following are not shown:	
9	Load disc kit
10	Quick guide

## 4.2 Dimensions

### PR 6043/30N+S

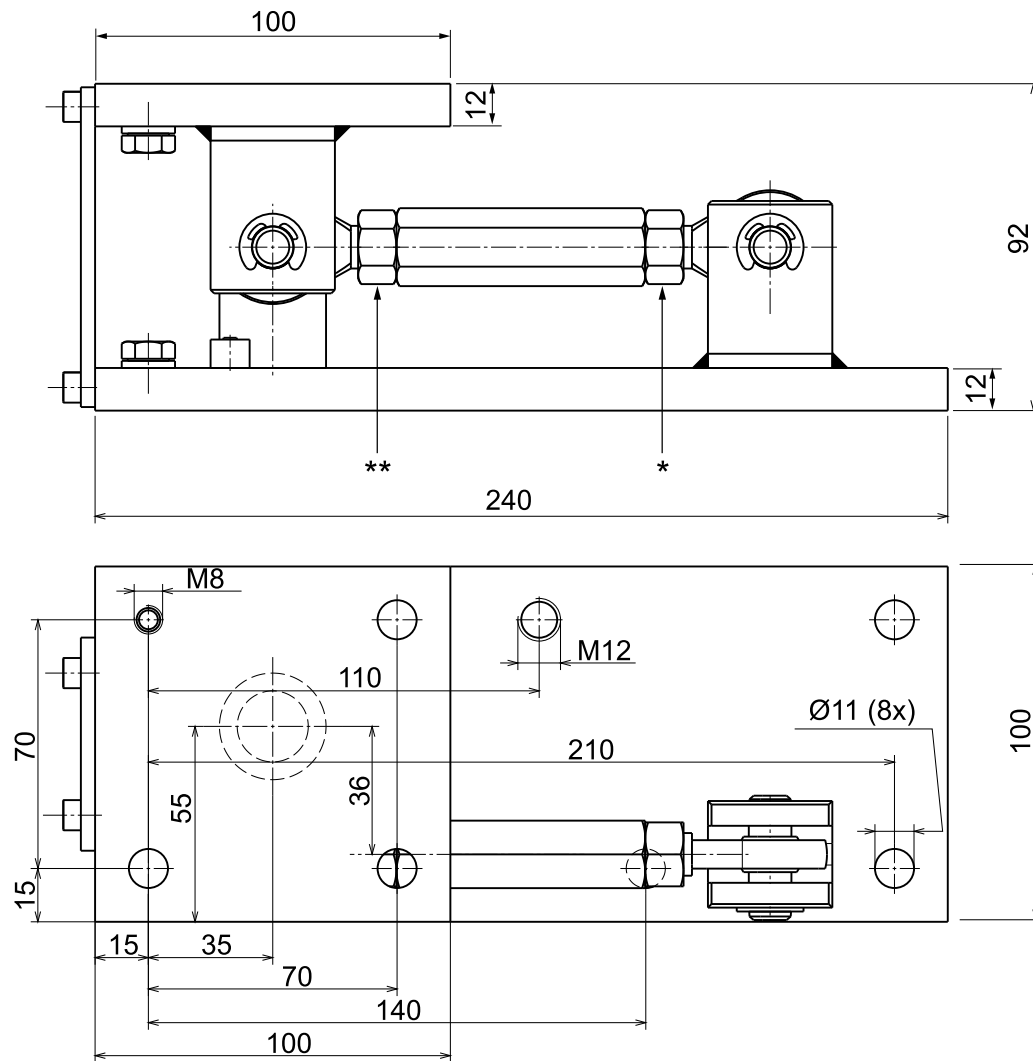

\* Right-hand thread, \*\* left-hand thread  
all dimensions in mm

**PR 6043/40N+S**

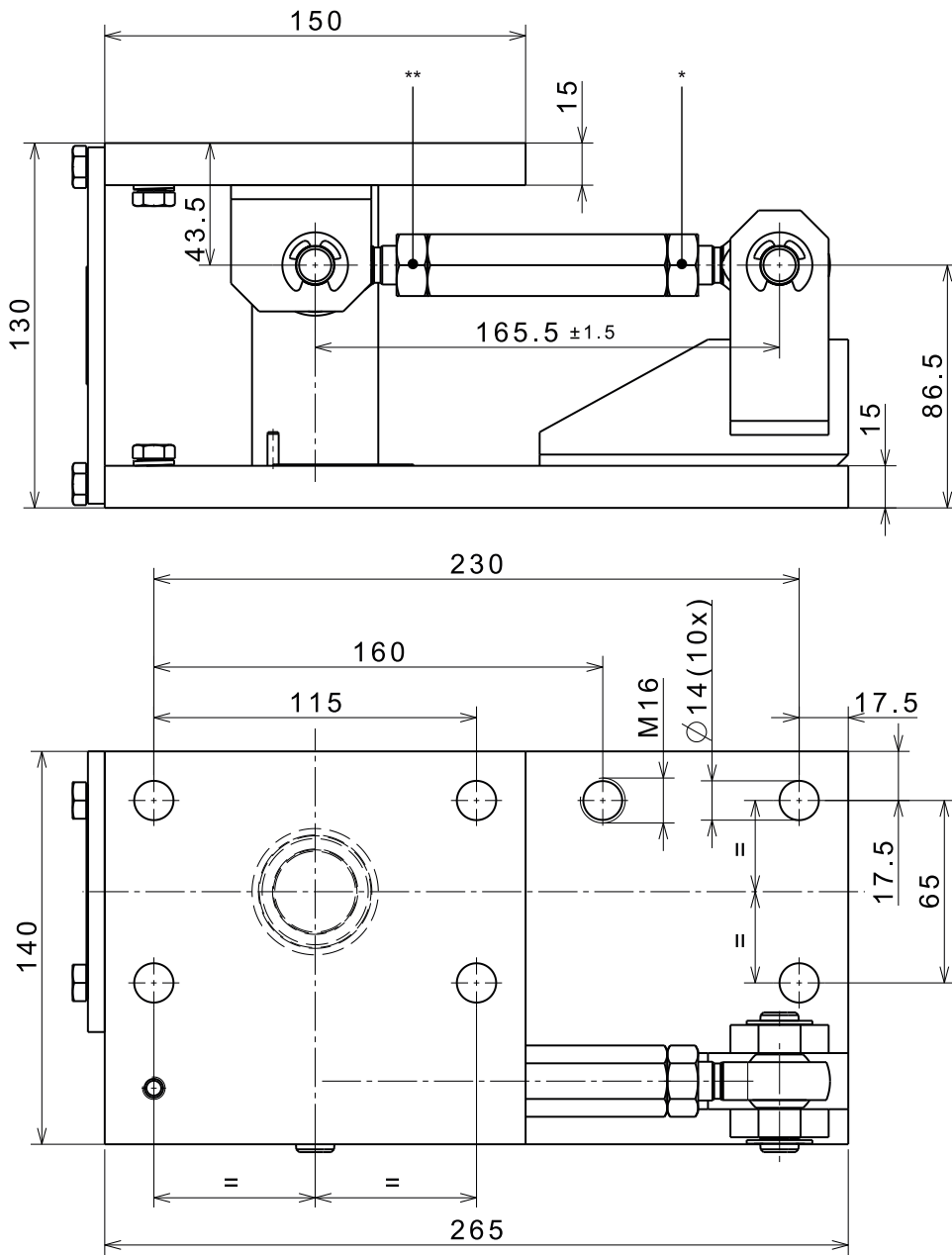

\* Right-hand thread, \*\* left-hand thread  
all dimensions in mm

### 4.3 Technical data

#### PR 6043/30N+S

	<b>PR 6043/30N</b>	<b>PR 6043/30S</b>
Max. capacity of load cell	100 kg...2 t	100 kg...2 t
Permissible horizontal force	max. 6 kN	max. 6 kN
Horizontal destructive force	>20 kN	>20 kN
Permissible vertical load without load cell (spacer)	max. 2 t	max. 2 t
Permissible temperature range	-40 °C...+100 °C	-40 °C...+100 °C
Material	Steel S235 with galv. zinc coating, passivated and sealed, RoHS-compliant	Stainless steel 1.4301 as per DIN EN 10088-3
Weight net/gross	4.3 kg/4.8 kg	4.3 kg/4.8 kg

#### PR 6043/40N+S

	<b>PR 6043/40N</b>	<b>PR 6043/40S</b>
Max. capacity of load cell	3 t, 5 t	3 t, 5 t
Permissible horizontal force	max. 18 kN	max. 18 kN
Horizontal destructive force	>50 kN	>50 kN
Permissible vertical load without load cell (spacer)	max. 5 t	max. 5 t
Permissible temperature range	-40 °C...+100 °C	-40 °C...+100 °C
Material	Steel S235 with galv. zinc coating, passivated and sealed, RoHS-compliant	Stainless steel 1.4301 as per DIN EN 10088-3
Weight net/gross	10.2 kg/10.6 kg	10.2 kg/10.6 kg

## 5 Installation

### 5.1 Prior to mounting

#### 5.1.1 Preparing the foundation/substructure

- The foundation for the mounting kit must be horizontal (use spirit level), flat, and rigid for the intended loads.
- The load distribution on the available load cells must be as even as possible to prevent overload of the individual load cells.
- The substructure foundations/supporting surfaces for the mounting kits should be at the same level, and the supporting surfaces of the weighing object (e.g. vessel feet) must be arranged in parallel.
- **For screw mounting of the upper and lower plates:**
  - Generate the drilling pattern of the upper plate of the mounting kit (see Chapter 4.2) according to the weighing system arrangement for each vessel lug or vessel foot.
- If soft filler layers (e.g. made from rubber or plastic material) are used between the mounting kit and vessel/or between the mounting kit and substructure for vibration dampening or for temperature insulation, a load compensating plate must be provided between this soft filler layer and the mounting kit to ensure even load application into the mounting kit.

The design of the insulation and compensation plates depends on the respective application.

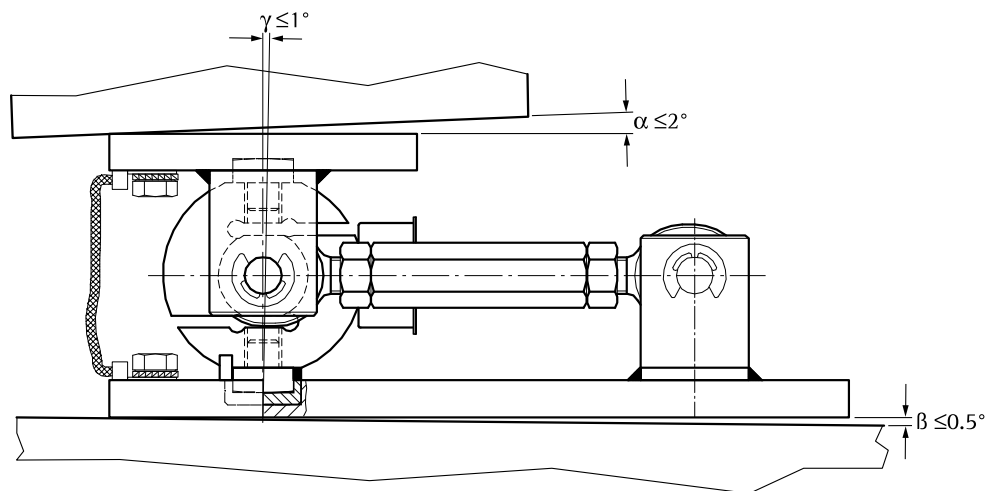

The maximum permissible inclination must be strictly observed in order to keep the impact on the measuring accuracy to a minimum (see figure).

## 5.2 Tightening torques

The corresponding tightening torques are given in the following table.

Mounting kit	Mounting parts	Thread	Washer	Tightening torque
PR 6043/30N	Upper plate	M8-8.8	*	85 Nm
	Lower plate	M8-8.8	*	85 Nm
PR 6043/30S	Upper plate	M8-A2-70	*	60 Nm
	Lower plate	M8-A2-70	*	60 Nm
PR 6043/40N	Upper plate	M12-8.8	**	85 Nm
	Lower plate	M12-8.8	**	85 Nm
PR 6043/40S	Upper plate	M12-A2-70	**	60 Nm
	Lower plate	M12-A2-70	**	60 Nm

*	Recommendation for the washers of M8 mounting screws:	DIN 7349 (d = 21, h = 4) or DIN 9021 or ISO 7093-2 (d = 24, h = 2)
**	Recommendation for the washers of M12 mounting screws:	DIN 7349 (d = 30, h = 6) or DIN 9021 or ISO 7093-2 (d = 37, h = 3)

## 5.3 Assembly

### 5.3.1 Safety instructions

#### WARNING

##### **The vessel may turn over during mounting.**

Securing the vessel against tipping is imperative.

- ▶ Use an appropriate lifting jack.

#### WARNING

##### **Warning of hazardous area and/or personal injury**

The locking washers of the constrainers may only be used once.

- ▶ Insert new washers in case they have been damaged or removed. Spare parts, see Chapter [8.1](#).

#### **NOTICE**

##### **Welding or lightning strike current flowing through the cell can damage it.**

All electrical welding on the weighing system must be finished before mounting the load cells.

- ▶ When installing the load cell, immediately bypass the load cell with a flexible copper strap (included in the load cell equipment).

During any additional electrical welding work near the load cell:

- Disconnect the load cell cables.
- Bypass the load cell using the flexible copper strap.
- Make sure that the grounding clamp of the welding set is fitted as closely as possible to the welding joint.

### 5.3.2 Installing the mounting kit and inserting the load cell

---

#### Note:

Screw mounting of the upper and lower plates is described below.

The operations must be performed at all supporting points (e.g., vessel) of the weighing object.

---

#### Requirements:

All threaded holes for the upper plate are available in the vessel lug/vessel foot (see Chapter 4.2).

#### Procedure:

Example: PR 6043/30

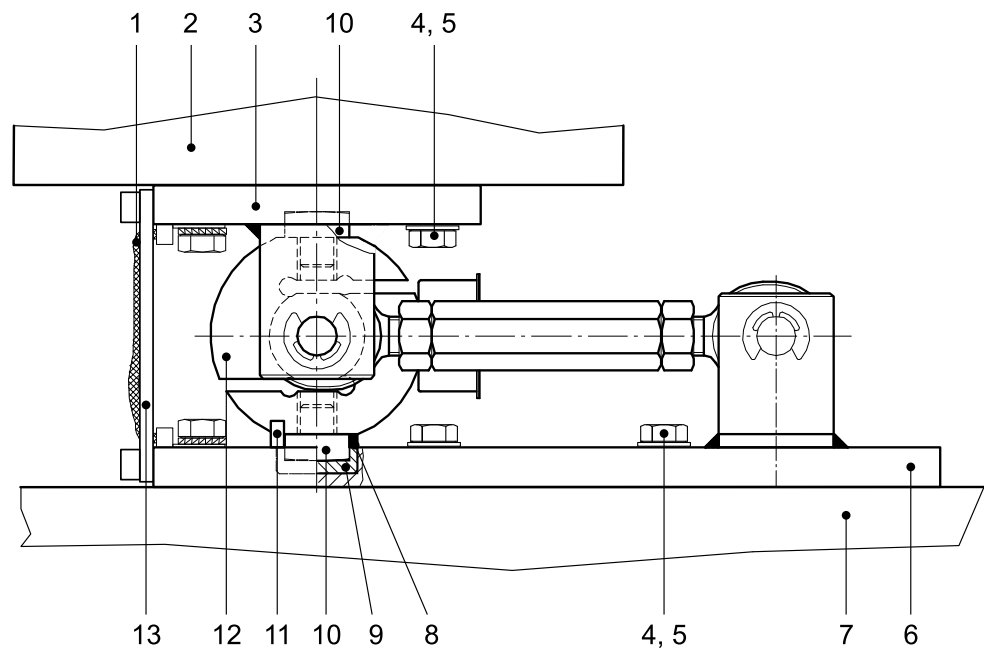

1. Fit the mounting kit to the vessel foot (2). It is essential to observe the property classes and tightening torques of the screws (4) and washers (5) (refer to Chapter 5.2).
2. Place the vessel and mounting kit in the required position on the foundation/substructure (7). Always make sure that the plates are parallel and seated vertically above each other.
3. Mark mounting holes for the lower plate (6).
4. Position the vessel with the mounting kit so that the drilling can be performed.
5. Secure the mounting kit to the foundation/substructure (7). Make sure to use the correct tightening torques (see Chapter 5.2).

6. Connect an equipotential bonding conductor (1) (not included) between the upper plate (3) and the lower plate (6).
7. Once all welding near the load cell and mounting work on the weighing object is complete, clean the recess for the load disc (10) in the upper plate (3) and the recess for the load plate (9) in the lower plate (6).

---

**Note:**

If required, the threaded bar, washers, and nuts can be mounted as additional lift-off protection (see Chapter 3.3).

---

8. Loosen the nut (17).
9. Turn the threaded bolt (16) upwards at the hex until the auxiliary mounting plate (1) is unloaded.
10. Position the lifting gear on the weighing object.
11. Remove the auxiliary mounting plate (13).
12. Remove the spacer (see Chapter 4.1).
13. **Only for PR 6043/30 with load cells PR 6241/12...52:** Take the two bushes out of the bag and fit them on the two pins (11).
14. Insert load plate (9) into the lower plate (6).

**⚠ CAUTION**

**Do not damage the membrane at the load cell side.**

- Carefully insert the load cell.
- 

15. Use appropriate lifting gear to lift the weighing object so that the load cell (12) can be positioned vertically with the two load discs in the mounting kit using the supporting ring (8)\*.  
The load cell must be seated centrally between the pins/bushes.
16. Load the load cell slowly. It is essential to ensure that the load cell is vertical and not jammed after loading.
17. If necessary, re-adjust the upper plate (3) and the lower plate (6).
18. If necessary, adjust the additional lift-off protection (see Chapter 3.3).

\* PR 6043/30: O-ring, PR 6043/40: silicone ring

## 5.4 Check mounting

When all mounting kits have been installed, check them for proper mounting. In particular, force shunts should be avoided.

**Example: PR 6043/30N+S**

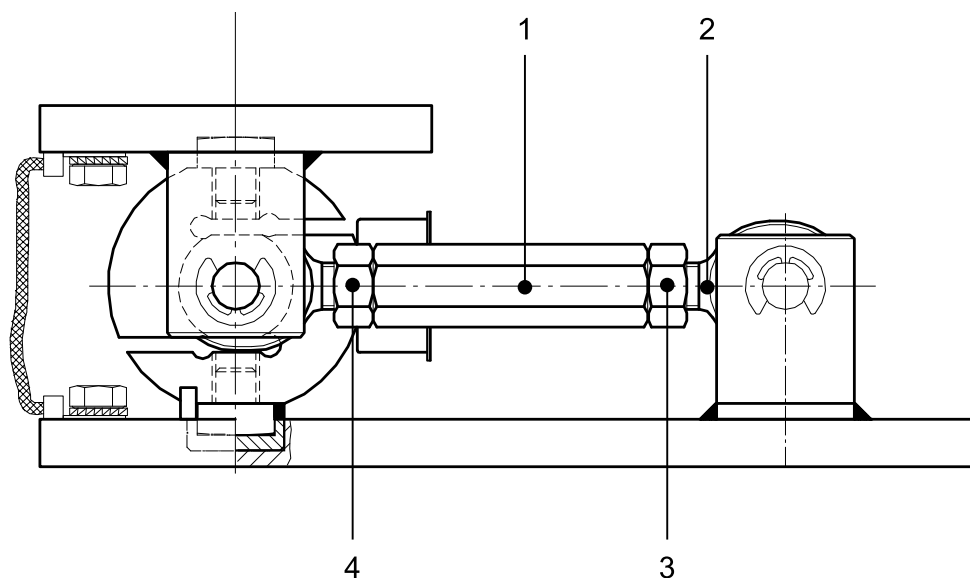

It is essential to check:

- whether the auxiliary mounting plate has been removed.
- whether the load cell has been inserted in the mounting kit vertically and without being canted.
- whether the upper and lower plates are mounted in a horizontal position.
- whether free moving space and the required play for thermal expansion are provided.
- whether the constrainters (2) have sufficient clearance; if necessary, loosen nuts (3\* and 4\*\*), adjust using the screwed joint (1) and retighten the nuts.

\* Right-handed thread, \*\* Left-handed thread

The free moving space which is required for displacement of the measured object due to thermal expansion, vibration, etc. can be utilized without reducing the measuring accuracy only if the load cell and constraining unit have been installed exactly.

To avoid force shunts, all incoming and outgoing lines (hoses, pipes, cables) must be connected to the measured object with the greatest flexibility possible.

The entire load must be supported by the load cells!

## 6 Cleaning

The mounting kit is easy to clean. It can be spray-washed with water.

For this purpose, spray the water jet from top to bottom and around the mounting kit.

### **NOTICE**

**Some cleaning agents may not be compatible with the mounting kit material.**

- ▶ When using cleaning agents, ensure that their compatibility with the mounting kit material has been tested and approved (see Chapter [4.3](#)).
-

## 7 Disposal

If the packaging is no longer required, please take it to your local waste disposal facility and/or a reputable disposal company or collection point. The packaging largely consists of environmentally friendly materials which can be used as secondary raw materials.

It is not permitted—even for small businesses—to dispose of this product with the regular household waste or at collection points run by local public waste disposal companies.

EU legislation requires its Member States to collect electrical and electronic equipment and dispose of it separately from other unsorted municipal waste so that it can then be recycled.

Before disposing of or scrapping the product, any batteries should be removed and taken to a suitable collection point.

Please see our T&Cs for further information.

Service addresses for repairs are listed in the product information supplied with the product and on our website ([www.minebea-intec.com](http://www.minebea-intec.com)).

We reserve the right not to accept products that are contaminated with hazardous substances (ABC contamination) for repair.

Should you have any further questions, please contact your local service representative or our service center.

Minebea Intec GmbH

Repair center

Meiendorfer Strasse 205 A

22145 Hamburg, Germany

Phone: +49.40.67960.666

[service.HH@minebea-intec.com](mailto:service.HH@minebea-intec.com)

## 8 Spare parts and accessories

### 8.1 Replacement parts

No.	Description	Max. capacity	Order no.
1	Flexible copper thread, 250 mm long		5312 321 28056
2	Load disc kit (incl. O-ring)	100 kg...2 t	5312 693 98132
3	Load disc kit (incl. silicon Load disc)	3 t, 5 t	5312 693 98076
4	2×locking washer, 9 mm, DIN 6799 9-A2	for PR 6043/30	5312 530 78001
5	2× locking washer, 12 mm, DIN 6799 12-A2	for PR 6043/40	5312 530 78003

### 8.2 Accessories

#### 8.2.1 Load discs

To install the load cell, the following load discs are recommended:

No.	Description	Max. capacity	Order no.
1	Load disc kit PR 6043/31S (incl. O-ring)	100 kg–2 t	9405 360 43312

S = stainless steel

Published by  
Minebea Intec GmbH | Meiendorfer Strasse 205 A | 22145 Hamburg, Germany  
Phone: +49.40.67960.303 | Email: [info@minebea-intec.com](mailto:info@minebea-intec.com)  
[www.minebea-intec.com](http://www.minebea-intec.com)

