

Instrument Manual

X3 Process Indicator PR 5410



Translation of the original instrument manual

9499 050 54103

Edition 12.8.0

10/13/2023

Release 4.60.xx-Exx

Foreword

Must be followed!

Any information in this document is subject to change without notice and does not represent a commitment on the part of Minebea Intec unless legally prescribed. This product should only be operated/installed by trained and qualified personnel. In correspondence concerning this product, the type, name, and release number/serial number as well as all license numbers relating to the product have to be cited.

Note

This document is partially protected by copyright. It may not be changed or copied, and it may not be used without purchasing or written permission from the copyright owner (Minebea Intec). The use of this product constitutes acceptance by you of the abovementioned provisions.

Table of contents

1	Introduction.....	9
1.1	Read the manual.....	9
1.2	This is what operating instructions look like.....	9
1.3	This is what lists look like.....	9
1.4	This is what menu items and softkeys look like.....	9
1.5	This is what the safety instructions look like.....	9
1.6	Hotline.....	10
2	Safety instructions.....	11
2.1	General notes.....	11
2.2	Intended use.....	11
2.3	Initial inspection.....	11
2.4	Before operational startup.....	11
2.4.1	Installation.....	12
2.4.2	Opening the device.....	12
2.4.3	Supply voltage connection.....	12
2.4.4	Protective ground connection.....	13
2.5	RF interference suppression.....	14
2.6	Failure and excessive stress.....	14
2.7	Important note.....	14
2.8	Repairs and maintenance.....	14
2.8.1	General information.....	14
2.8.2	Electrostatically sensitive parts.....	14
2.8.3	Replacing fuses.....	15
3	Device description.....	16
3.1	General notes.....	16
3.2	Overview of the device.....	16
3.2.1	Communication protocols.....	17
3.3	Housing.....	17
3.3.1	General notes.....	17
3.3.2	Dimensions.....	18
3.3.3	Control panel cut-out.....	18
3.4	Display and operating elements.....	19
3.4.1	General information.....	19
3.4.2	Overview.....	19
3.4.3	Display.....	19
3.4.4	Operating elements.....	23
3.5	Overview of connections.....	29
3.5.1	Plug-in cards.....	30

4	Device installation.....	32
4.1	General notes	32
4.2	Mechanical preparation.....	32
4.3	Installing the device	33
4.4	EMC-compliant installation	34
4.4.1	Connecting the screens.....	34
4.4.2	Connecting the equipotential bonding conductor	34
4.5	Hardware construction	34
4.5.1	Main board	34
4.5.2	Display board.....	36
4.5.3	Network port.....	36
4.5.4	RS-232 interface.....	37
4.5.5	Digital inputs	41
4.5.6	Digital outputs.....	43
4.6	Connecting analog load cells and platforms.....	46
4.6.1	General information	46
4.6.2	Connecting a load cell with a 4-wire cable.....	47
4.6.3	Connecting a load cell with a 6-wire cable.....	48
4.6.4	Connecting between 2 and 8 load cells (650 Ω) using a 6-wire connection cable	49
4.6.5	Connecting load cells of type series PR 6221	50
4.6.6	Testing the measuring circuit	50
4.6.7	External supply to load cells.....	52
4.6.8	Connection to relay PR 1626/6x	53
4.6.9	Connecting an analog weighing platform (CAP... series).....	55
4.7	Accessories	58
4.7.1	General information	58
4.7.2	2x RS-232-interface	60
4.7.3	1x RS-232 interface and 1x RS-485 interface	62
4.7.4	CANopen interface.....	71
4.7.5	Connexx module	73
4.7.6	Analog inputs and outputs	79
4.7.7	BCD output (open emitter)	82
4.7.8	BCD output (open collector).....	86
4.7.9	Switch settings	90
4.7.10	Output modes	91
4.7.11	Opto-decoupled inputs and outputs.....	92
4.7.12	Status LEDs on fieldbus card.....	97
4.7.13	Profibus DP interface	97
4.7.14	InterBus-S interface.....	102
4.7.15	DeviceNet interface	107
4.7.16	CC-Link interface	111
4.7.17	ProfiNet I/O interface.....	113

4.7.18	EtherNet/IP interface	117
5	"Standard" application	120
5.1	Functions.....	120
5.1.1	General information	120
5.1.2	Display functions.....	120
6	"EasyFill" application	121
6.1	Functions.....	121
6.1.1	General information	121
6.1.2	Display functions.....	121
6.1.3	Filling mode	121
6.2	Application menu [Start]	121
7	Getting started	123
7.1	Power failure/Data backup/Restart	123
7.1.1	Power failure.....	123
7.1.2	Data backup	123
7.1.3	Overwrite protection	123
7.1.4	Restart	124
7.2	Switching on the device.....	125
7.2.1	Setting the date and time	126
7.3	Switching off the device	127
7.4	Warm-up time	127
7.5	Configuring and calibrating using the front-panel keys.....	127
7.5.1	Parameter table (SEtuP).....	127
7.5.2	Recalibrating the internal weighing point using the front-panel keys	131
7.5.3	Changing the dead load of the internal weighing point using the front-panel keys.....	134
7.5.4	Displaying the calibration data of the internal WP using the front-panel keys.....	135
7.5.5	Reading out calibration data for WP dead load and max using the front-panel keys.....	137
7.5.6	Search for Pendeo load cells and set dead load using the front-panel keys	138
7.5.7	Creating a PIN code using the front-panel keys	139
7.5.8	Deleting the PIN code using the front-panel keys	140
7.5.9	Entering fieldbus parameters using the front-panel keys	141
7.5.10	Entering the network address using the front-panel keys.....	143
7.5.11	Displaying the network address using the front-panel keys	145
7.6	Displaying/deleting alibi entries using the front-panel keys.....	146
7.6.1	Displaying/deleting alibi entries	146
7.6.2	Deleting alibi entries.....	148
7.7	Finding and connecting a device with a notebook/PC.....	148
7.8	Finding and connecting the device automatically in the network.....	149
7.9	Searching the device in the network with "IndicatorBrowser".....	149
7.10	Resetting the network address	150
7.11	Operation using VNC	151

7.12	Operation via a web browser	152
7.13	System setup	153
7.13.1	Serial ports parameter	153
7.13.2	Date & time	154
7.13.3	Operating parameters	154
7.13.4	Printing parameter	154
7.13.5	Fieldbus parameter	155
7.13.6	Network parameter	155
7.13.7	Weighing points	155
7.13.8	Limit parameter	163
7.13.9	Digital I/O parameters	164
7.13.10	Analog output parameter	164
7.14	Calibrating internal weighing point	164
7.14.1	General information	164
7.14.2	Displaying calibration data	165
7.14.3	Selecting the calibration mode	166
7.14.4	Setting maximum load	169
7.14.5	Determining the scale interval	170
7.14.6	Determining the dead load	171
7.14.7	Calibrating with weight	172
7.14.8	Calibrating with mV/V	174
7.14.9	Calibrating with load cell data (smart calibration)	176
7.14.10	Subsequent dead load correction	177
7.14.11	Linearization	178
7.14.12	Calculating the test value	178
7.14.13	Saving the calibration	179
7.14.14	Cancelling a calibration	180
7.14.15	Parameter Input	181
7.15	Calibrating xBPI-scale	187
7.15.1	General information	187
7.15.2	Parameters for serial interface	187
7.15.3	Parameters for the xBPI-weighing function	188
7.15.4	Setting up an xBPI platform	189
7.15.5	xBPI-parameter tables	192
7.15.6	Setting the xBPI dead load	195
7.15.7	xBPI calibration with user specified weight	196
7.15.8	xBPI calibration with automatic weight detection	198
7.15.9	xBPI calibration with default weight	198
7.15.10	xBPI calibration with built-in weight	199
7.15.11	xBPI linearization	200
7.16	Calibrating digital load cells of type "Pendeo"	201
7.16.1	General information	201

7.16.2	Selecting and configuring RS-485 interface	202
7.16.3	Selecting the load cell type	203
7.16.4	Calibration procedure	203
7.16.5	Searching load cells	204
7.16.6	Assigning load cells	206
7.16.7	Calibrating load cells	207
7.16.8	Assigning load cell names	209
7.16.9	Service function.....	209
7.16.10	Corner correction	211
7.16.11	Terminating/saving calibration	212
7.16.12	Parameter Input.....	212
7.16.13	Subsequent dead load correction	214
7.16.14	Displaying weighing point serial number	215
7.17	Calibrate load cells incl. Connexx module	215
7.17.1	General notes	215
7.17.2	Selecting the load cell type	215
7.17.3	Calibration procedure	216
7.17.4	Search for load cells.....	216
7.17.5	Assign load cells	218
7.17.6	Calibrate load cells.....	219
7.17.7	Assign load cell name.....	221
7.17.8	Service function.....	221
7.17.9	Corner correction	223
7.17.10	Terminating/saving calibration	224
7.17.11	Parameter input	224
7.18	General parameter settings	228
7.18.1	Selecting and configuring serial interfaces	228
7.18.2	Date and time	237
7.18.3	Operating parameters.....	238
7.18.4	Print parameters	240
7.18.5	Fieldbus parameters.....	241
7.18.6	Network parameters.....	244
7.18.7	Configuring limit values.....	245
7.18.8	Configuring digital inputs.....	251
7.18.9	Configuring digital outputs.....	254
7.18.10	Configuring analog output.....	259
7.19	System information.....	260
7.19.1	Displaying the version.....	261
7.19.2	Displaying the status.....	262
7.19.3	Showing hardware options	263
7.19.4	Displaying the alibi memory	264
7.19.5	Displaying Pendeo data	265

7.19.6	Show Connexx data	267
8	Production	270
8.1	General notes	270
8.2	Configuration using the front-panel keys	270
8.2.1	Configuring production mode using the front-panel keys	270
8.2.2	Configuring interaction mode using the front-panel keys	271
8.2.3	Configuring digital inputs and outputs using the front-panel keys	271
8.2.4	Configuring printout using the front-panel keys	273
8.3	Starting the application	276
8.4	Configuration via a notebook/PC	276
8.4.1	Configuring production mode	276
8.4.2	Configuring digital inputs and outputs	280
8.4.3	Configuring material	282
8.4.4	Configuring printout	284
8.5	Filling	286
9	Extended functions	288
9.1	Hardware test	288
9.1.1	Display test	288
9.1.2	Front-panel key test	288
9.1.3	Serial interfaces	289
9.1.4	Inputs and outputs	289
9.2	Functions via the WEB site	295
9.2.1	General information	295
9.2.2	Displaying weighing points in a table	296
9.2.3	Configuration printout	296
9.2.4	Log files	297
9.2.5	Screenshots	298
9.2.6	Error log	298
9.2.7	Alibi memory	299
9.2.8	Configuration data	302
9.3	Resetting the device to the factory settings using the front-panel keys	303
9.4	Resetting the device to the factory settings	304
9.5	Updating new software with FlashIt	305
9.5.1	Updating in network with a DHCP service	305
9.5.2	Updating via a point-to-point connection with DHCP service	307
9.5.3	Updating with a fixed IP address	308
10	ModBus protocol	312
10.1	General description	312
10.2	SPM data in PR 1612 ModBus mode	312
11	SMA protocol	314

11.1	General information	314
12	Fieldbus interface	315
12.1	General notes	315
12.2	Scale protocol (8-byte) for the "Standard" application	315
12.2.1	Data exchange range	316
12.2.2	Reading and writing data with function numbers.....	318
12.2.3	Reading and writing bits directly	320
12.2.4	Waiting for the result of the action	320
12.2.5	Function numbers.....	321
12.2.6	Example: reading the gross weight.....	326
12.2.7	Special note for DeviceNet and EtherNet IP.....	327
12.3	Filling protocol (64-Byte) for the "EasyFill" application	327
12.3.1	Write window (input area).....	327
12.3.2	Read window (output area)	327
12.3.3	Indicator functions.....	328
12.3.4	Filling functions.....	328
12.3.5	Setup of the fieldbus interface	330
13	SPM	336
13.1	General information	336
13.2	Elementary data types.....	336
13.3	Addressing.....	337
13.4	System data	337
14	Repairs and maintenance	343
14.1	Repairs.....	343
14.1.1	Battery for date/time	343
14.1.2	Changing the battery for date/time	343
14.1.3	Replacing fuse	344
14.2	Maintenance.....	344
14.3	Soldering work.....	344
14.4	Cleaning	345
15	Disposal	346
16	Error messages	347
16.1	Error messages measuring circuit.....	347
16.2	Error messages for xBPI scales.....	348
16.3	Error messages for Pendeo load cells	348
16.4	Error messages during calibration.....	349
16.5	General error messages.....	351
16.6	Error numbers @ "LAST_ERROR"	353
16.6.1	Weighing point error	353
16.6.2	Error in the "EasyFill" application	353

17	Technical data	355
17.1	Note on using "free software"	355
17.2	Decoding the serial number.....	355
17.3	General data	355
17.3.1	Backup for date/time	355
17.3.2	Supply voltage connection 230 V AC.....	355
17.3.3	Supply voltage connection 24 V DC.....	355
17.4	Effect of ambient conditions	356
17.4.1	Ambient conditions	356
17.4.2	Electromagnetic Compatibility (EMC).....	356
17.4.3	RF interference suppression	356
17.5	Weighing electronics.....	357
17.5.1	Load cells.....	357
17.5.2	Principle.....	357
17.5.3	Accuracy and stability	357
17.5.4	Sensitivity.....	358
17.5.5	Connecting cables.....	358
17.6	Mechanics	358
17.6.1	Design	358
17.6.2	Weights.....	358
17.7	Documentation on the CD included	358
18	Appendix	359
18.1	Replacement parts	359
18.2	Test connector.....	360
18.3	Certificates.....	360

1 Introduction

1.1 Read the manual

- Please read this manual carefully and completely before using the product.
- This manual is part of the product. Keep it in a safe and easily accessible location.

1.2 This is what operating instructions look like

1. - n. are placed before steps that must be done in sequence.
 - ▶ is placed before a step.
 - ▷ describes the result of a step.

1.3 This is what lists look like

- indicates an item in a list.

1.4 This is what menu items and softkeys look like

[] frame menu items and softkeys.

Example:

[Start]- [Applications]- [Excel]

1.5 This is what the safety instructions look like

Signal words indicate the severity of the danger involved when measures for preventing hazards are not followed.

DANGER

Warning of personal injury

DANGER indicates death or severe, irreversible personal injury which will occur if the corresponding safety measures are not observed.

- ▶ Take the corresponding safety precautions.

WARNING

Warning of hazardous area and/or personal injury

WARNING indicates that death or severe, irreversible injury may occur if appropriate safety measures are not observed.

- ▶ Take the corresponding safety precautions.

CAUTION

Warning of personal injury.

CAUTION indicates that minor, reversible injury may occur if appropriate safety measures are not observed.

- ▶ Take the corresponding safety precautions.

NOTICE**Warning of damage to property and/or the environment.**

NOTICE indicates that damage to property and/or the environment may occur if appropriate safety measures are not observed.

- ▶ Take the corresponding safety precautions.
-

Note:

User tips, useful information, and notes.

1.6 Hotline

Phone: +49.40.67960.444

Fax: +49.40.67960.474

eMail: help@minebea-intec.com

2 Safety instructions

2.1 General notes

CAUTION

Warning of personal injury.

This device has been built and tested in compliance with the safety regulations for measuring and control equipment for protection class I (protective grounding conductor) according to IEC 1010/EN 61010 or VDE 0411.

The device was in perfect condition with regard to safety features when it left the factory.

- ▶ To maintain this condition and to ensure safe operation, the user must follow the instructions and observe the warnings in this manual.

2.2 Intended use

The device is intended for use of the analysis device for weighing functions.

Product operation, commissioning and maintenance must be performed by trained and qualified personnel who are aware of and able to deal with the related hazards and take suitable measures for self-protection.

The device reflects the state of the art.

The manufacturer does not accept any liability for damage caused by third-party system components or due to incorrect use of the product. The use of this product signifies recognition of the stipulations listed above.

Only for PR 5410/04

PR 5410/04 is designed for use in the USA and Canada and has UL approval.

The device is not compliant with directives that allow CE marking and also does not have OIML approval.

2.3 Initial inspection

Check the contents of the consignment for completeness. Check the contents visually to determine whether any damage has occurred during transport. If there are grounds for rejection of the goods, a claim must be filed with the carrier immediately. The Minebea Intec sales or service organization must also be notified.

2.4 Before operational startup

NOTICE

Perform visual inspection.

- ▶ Before operational startup as well as after storage or transport, inspect the device visually for signs of mechanical damage.

2.4.1 Installation

The device is suitable for installation in control panels or cabinets.

The device has to be installed in an EMC-compliant manner, see Chapter [4.4](#).

Component	Protection class	Installation
Housing front	IP65	Suitable for any operating environment.
Housing rear panel	IP30	

To ensure proper cooling of the device, make sure air circulation around the device is not blocked. Avoid exposing the instrument to excessive heat, e.g. from direct sunlight, and vibrations. The ambient conditions in Chapter [17.4.1](#) must be taken into account at all times.

With outdoor mounting, make sure that adequate weather protection is provided (for temperatures, see Chapter [17.4.1](#)).

2.4.2 Opening the device

WARNING

Working on the device while it is switched on may have life-threatening consequences.

When removing covers or parts using tools, live parts or terminals may be exposed. Please note that capacitors in the device may still be charged even after disconnecting the device from all voltage sources.

- ▶ Disconnecting the device from the power supply.

This device contains electrostatically sensitive components. For this reason, an equipotential bonding conductor must be connected when working on the open device (antistatic protection).

2.4.3 Supply voltage connection

The device does not have a power switch. It is in operation as soon as the power is connected.

2.4.3.1 Version 230 V AC



Safe interruption of both supply voltage conductors must be provided for, either by disconnecting the power connector or using a separate switch.

The device is equipped with a wide range power supply and covers AC systems with a frequency of 50/60 Hz and a voltage range of $U_{AC} = 100$ to 240 V -15/+10 % automatically (without manual selection).

The power supply is protected against short circuits and overloads, and disconnects automatically in case of a fault.

If the electrical protection has triggered:

- Disconnect the device from all power sources and wait at least 1 minute.
- Determine and eliminate the cause of the error.
- Reconnect the device to the supply voltage.

2.4.3.2 Version 24 V DC

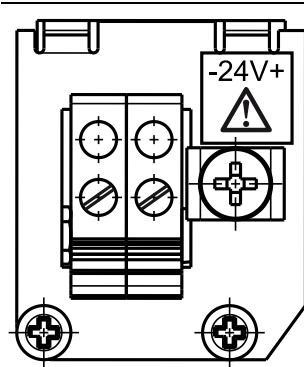

The PR 5410/01 version is designed for 24 V direct current.

The supply is established via two screw terminals (- 24 V +). The device is protected against incorrect polarity.

The device is protected (primary side) via an internal fuse in the – line (see Chapter [17.3.3](#)).

2.4.4 Protective ground connection

2.4.4.1 Version 230 V AC

The device must be connected to a protective ground via a protective grounding conductor (PA) in the network plug.

The power cable contains a protective grounding conductor which must not be interrupted inside or outside the device.

The protective grounding conductor is connected to the back of the housing inside the device.

2.4.4.2 Version 24 V DC

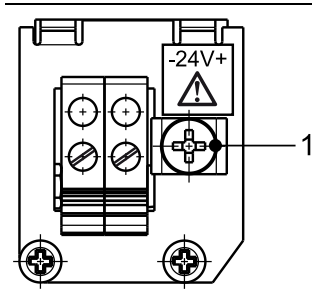

The housing rear panel must be connected to the protective grounding conductor and fixed using screw (1).

2.5 RF interference suppression

The device is intended for use in an industrial environment. Operation of this device in a residential environment is likely to cause radio frequency interference, see Chapter [17.4.3](#). In this case, the operator may be required to take appropriate measures.

2.6 Failure and excessive stress

If there is any reason to assume that safe operation of the device is no longer ensured, shut it down and make sure it cannot be used.

Safe operation is no longer ensured if any of the following is true:

- The device is physically damaged.
- The device does not function.
- The device has been subjected to stresses beyond the tolerance limits (e.g., during storage or transport).

2.7 Important note

Make sure that the construction of the device is not altered to the detriment of safety. In particular, leakage paths, air gaps (of live parts) and insulating layers must not be reduced.

Minebea Intec cannot be held responsible for personal injury or property damage caused by a device repaired incorrectly by an operator or installer.

2.8 Repairs and maintenance

2.8.1 General information

Repairs are subject to inspection and must be carried out at Minebea Intec.

In case of defect or malfunction, please contact your local Minebea Intec dealer or service center for repair.

When returning the device for repair, please include a precise and complete description of the problem.

Maintenance work may only be carried out by a trained technician with expert knowledge of the hazards involved and the required precautions.

2.8.2 Electrostatically sensitive parts

This device contains electro-statically sensitive components. Therefore, potential equalization must be provided when working on the device (antistatic protection).

2.8.3 Replacing fuses

2.8.3.1 Changing fuses in an ex area

⚠ WARNING

Explosion possible if replacement is not done correctly!

- ▶ It is only permitted to replace fuses in the PR 5410 when used in the ex area, if the atmosphere is not potentially explosive.
- ▶ Only the fuses listed in Chapter [17.3.3](#) are permissible.

2.8.3.2 Replacing fuses in a secure area

⚠ WARNING

Damage from overheating.

The use of repaired fuses and bypassing the fuse holder is prohibited.

- ▶ Only the fuses listed in chapters [17.3.2](#) and [17.3.3](#) are permissible.

3 Device description

3.1 General notes

The instrument is equipped with a six-digit 7-segment display and additional status displays. Local operation is possible using the 6 double function keys.

The instrument contains two applications:

- Default
- EasyFill

Most functions are supported by both applications.

A few functions are application-dependent.

3.2 Overview of the device

- Accuracy 10,000 e (class III) for the weighing electronics
- High-speed conversion with measurement times from 10 msec
- Weight display with status via transfective, 6-digit, 7-segment display
- Alibi memory
- 6 function keys for operation on the front panel
- Enclosed front: IP65, back: IP30
- LAN adapter with 10/100 Mbit/s for data transfer, calibration, parameterization
- Integrated RS-232 interface for, e.g., printer or remote display
- Can be expanded using the following plug-in cards (2 slots):
 - Serial input and output card 2× PR 5510/02 or 2× PR 5510/04
1× PR 5510/02 and/or 1× PR 5510/04
 - CANopen interface PR 5510/05
 - Analog input and output card PR 5510/07
 - BCD output card PR 5510/08 (Slot 2 only) or PR 5510/09 (Slot 2 only)
 - Opto-decoupled input and output card PR 5510/12
 - Fieldbus cards PR 1721/3x
- Electrically isolated interfaces (except RS-232)
- Wide range power supply for $U_{AC} = 100$ to 240 V, protection class I (protective grounding conductor)
- Version PR 5410/01 for $U_{DC} = 24$ V
- Plug-in connections inside the device for load cells, inputs/outputs, LAN adapter
- Installation as control panel or control cabinet device
- Calibrate using the front keypad or PC tool (browser/VNC); calibrate the Pendeo® load cells and Connexx modules using the PC tool only
- Calibration using weights according to the mV/V method or directly using load cell data (smart calibration)

- Software configuration of the interface cards, e.g., for remote display or printer
- The "EasyFill" application allows for quick and reliable filling and emptying of vessels (for functional description, see Chapter [6.1](#)).
- Analog test for the weighing electronics
- Overwrite protection using CAL switch on the main board

3.2.1 Communication protocols

For the internal RS-232 or external RS-232 + RS-485 (accessories):

- Remote display protocol
- Printer
- ModBus-RTU (slave)
- SMA protocol
- xBPI protocol
- EW-Com protocol

Field bus slave (accessories):

- PR 1721/31 ProfiBus DP
- PR 1721/32 InterBus-S
- PR 1721/34 DeviceNet
- PR 1721/35 CC-Link
- PR 1721/36 ProfiNet I/O
- PR 1721/37 EtherNet-IP

For the internal LAN:

- ModBus-TCP
- Ethernet TCP/IP
- OPC-UA, refer to the corresponding documentation

3.3 Housing

3.3.1 General notes

The instrument has a housing of aluminum with IP65 front. It can be used as a control panel version.

The keypad and the display form one unit with the front. A rectangular cut-out is required for the installation. Cable connections are made at the back of the housing.

The ambient conditions specified for the instrument must be observed (see Chapter [17.4.1](#)).

The gaps for attaching 2 plug-in cards are closed by blind plates.

3.3.2 Dimensions

Front view

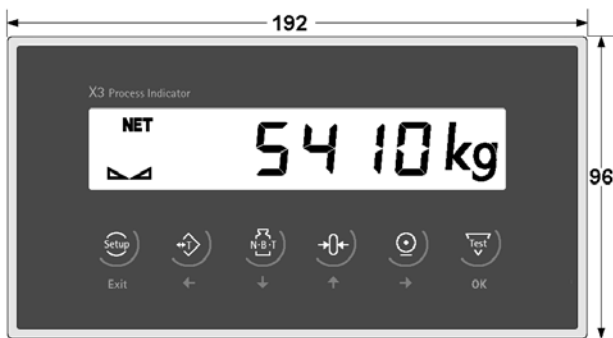

all dimensions in mm

Side view

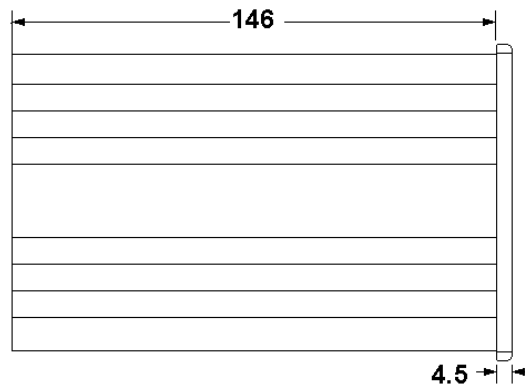

all dimensions in mm

Back view

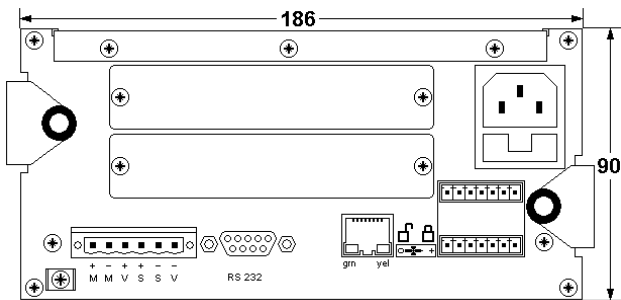

all dimensions in mm

3.3.3 Control panel cut-out

The control panel cut-out must be made before installing the device.

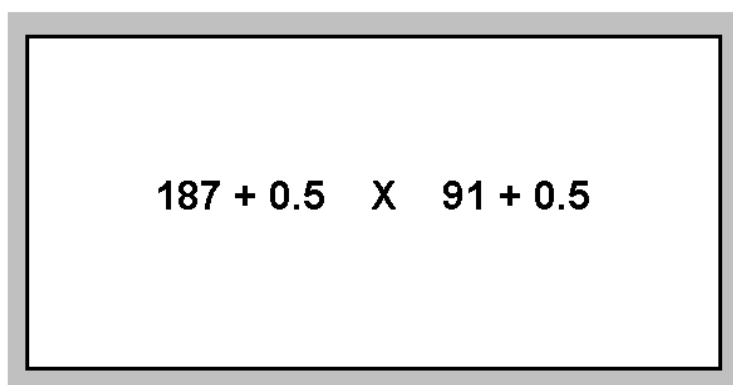

all dimensions in mm

3.4 Display and operating elements

3.4.1 General information

The PR 5410 process indicator can only be operated using the front-panel keys or by Notebook/PC.

- Operation using the front-panel keys (see Chapter 7.5.2)
- VNC viewer (see Chapters 3.4.4.4 and 7.11) or
- WEB browser (see Chapter 7.12)

3.4.2 Overview



3.4.3 Display

3.4.3.1 User interface

The user interface display can show weight values of up to 7 digits with decimal point and plus or minus sign.



The available mass units are t, kg, g, or lb.

The lb unit is not permitted for use in legal metrology in the EU and EEC.

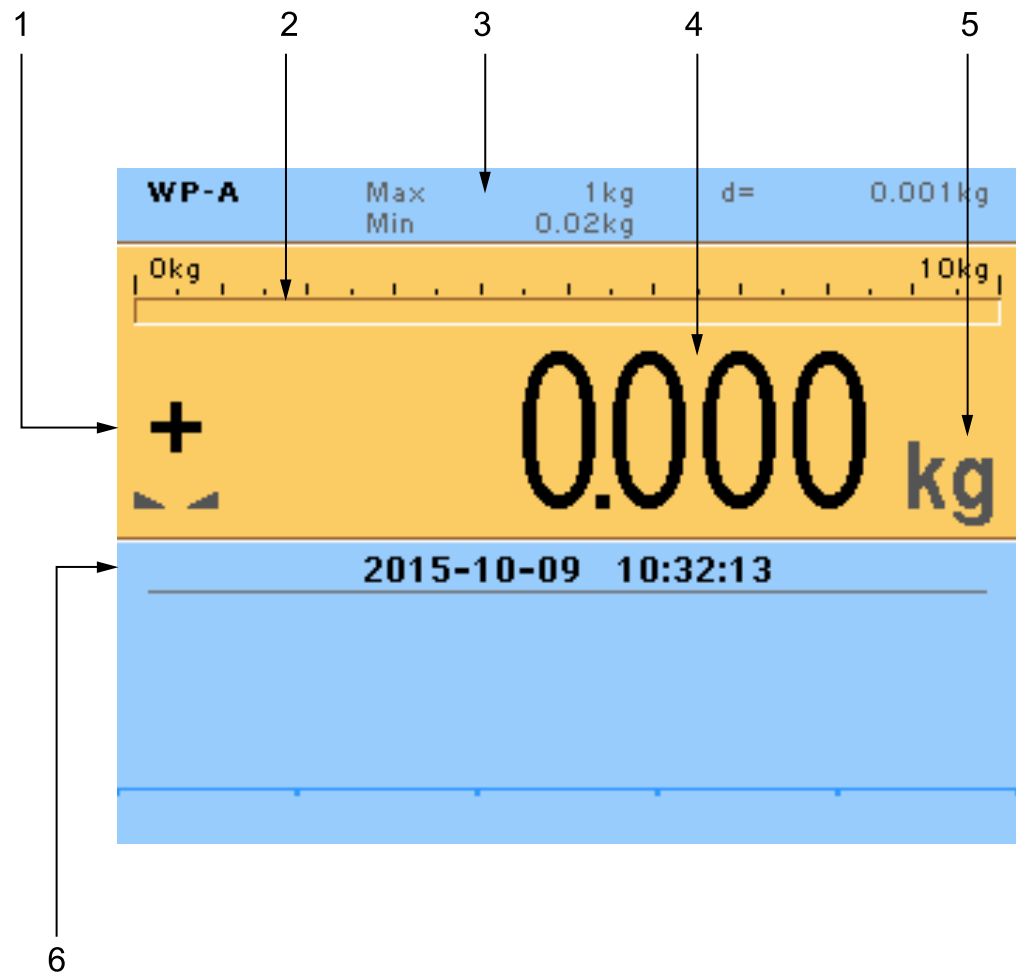
Above the weight display on the user interface, the currently displayed weight is shown in a bar graph that indicates the percentage of the maximum capacity (Max). 0 is on the left, and 100% on the right.



No.	Description
1	Weight type/plus or minus sign/standstill
2	Bar graph
3	Status display
4	Weight value
5	Symbols/mass unit
6	Info line

Weight type/plus or minus sign	Description
B	Gross weight
G	Gross weight in NTEP or NSC mode
NET	Net weight (Net = gross - tare)
T	Tare weight
PT	Preset tare
TST	The weight display shows the test value without mass unit.
No display	- Test value - Gross, not tared
+	Positive value
-	Negative value
<hr/>	
Standstill/zero	Description
	Weight value standstill
→0←	The gross weight value is within $\pm\frac{1}{4}$ d of zero
	Batching mode: flashes when batching is "stopped"; rapid flashing indicates "error status"
<hr/>	
Symbols/mass unit	Description
	Value not permissible in legal metrology (e.g., 10x resolution, deactivated load cell)
R1	Range 1
R2	Range 2
R3	Range 3
WPA	Weighing point A
Max	Maximum capacity (weighing range)
Min	Minimum weight
t, kg, g, lb	These mass units are available.

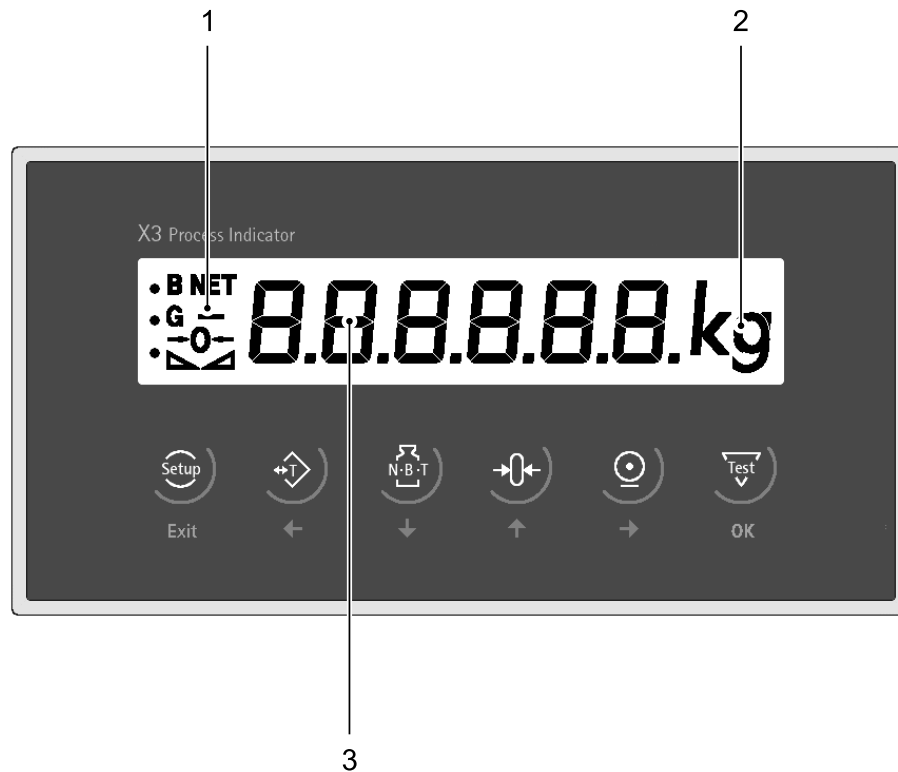

3.4.3.2 Instrument display

6-digit weight values (digit height 18 mm) with the decimal points can be shown on the display.



No.	Description
1	Weight type/plus or minus sign/standstill
2	Symbols/mass unit
3	Weight value

Weight type/plus or minus sign	Description
B	Gross weight
G	Gross weight in NTEP or NSC mode
NET	Net weight (Net = gross - tare)
T	Tare weight
PT	Preset tare
No display	- Test value - Gross, not tared
TST	The weight display shows the test value without mass unit.
+	Positive value
-	Negative value





Standstill/zero/dosing	Description
	Weight value standstill
	The gross weight value is within $\pm 1/4$ d of zero
	Batching mode: flashes when batching is "stopped"; rapid flashing indicates "error status"
Symbols/mass unit	Description
•	Range 1
•	Range 2
•	
•	Range 3
•	
•	
t, kg, g, lb	These mass units are available.

3.4.4 Operating elements





3.4.4.1 User interface

The following tables show the basic meanings of symbols on the operator interface.

Indicator keys

	Display gross weight		Sets gross weight to zero, provided that <ul style="list-style-type: none"> - weight value is stable; - weight is within zero setting range. This function depends on the configuration.
	Display tare weight.		Starts a printout.
	Taring The current gross weight is stored in the tare memory, provided that <ul style="list-style-type: none"> - weight value is stable; - the instrument is not in error status. This function depends on the configuration.		

Navigation/menu keys

	Scroll up in the menu.		Confirm input/selection.
	Scroll down in the menu.		<ul style="list-style-type: none"> - Backspace - Pressing the delete key deletes individual characters (within an entry).

Navigation/menu keys



- Cursor to the left
- Selection



- Cancel entry/selection (after a confirmation prompt) without saving the change.
 - Exit parameters/menu window.
-



- Cursor to the right
 - Selection
-

Function keys/softkeys



Access the Setup menu.



Depending on the settings under  -[Weighingpoint]- [Calib]- [Param]- [Test mode] the following is displayed by calling the test with the key later on:

- with "Absolute" the maximum load
- with "Relative" the deviation from test value.



Information on version number, fitted hardware, 10-fold resolution

Softkeys 1...5

Select appropriate menu function, see also Chapter [3.4.4.2](#).



No function

Alphanumeric keypad

Toggle key

Toggle by pressing:



- between alpha and numerical mode
- during configuration between weight units



Alphanumeric keypad



Pressing once displays the corresponding first character, e.g., "A", at the cursor position. After pressing twice, "B" is displayed at the cursor position and after pressing three times, "C" is displayed.

Press the / cursor key to finish entering a character or wait approx. 2 seconds.

If only numeric values are required for input, letters are not enabled.

Press the  cursor key within an entry to return to the previous character.

Press the  cursor key within an entry to select the next character.

Within an input, pressing the  delete key deletes the character to the left of the cursor.

Input field

In principle

If alphanumeric characters are already present in the input field of the selected line, they will be completely overwritten after immediate entry.

If alphanumeric characters are already present in the input field of the selected line, you can press the  cursor key to select the characters to be overwritten and overwrite them.

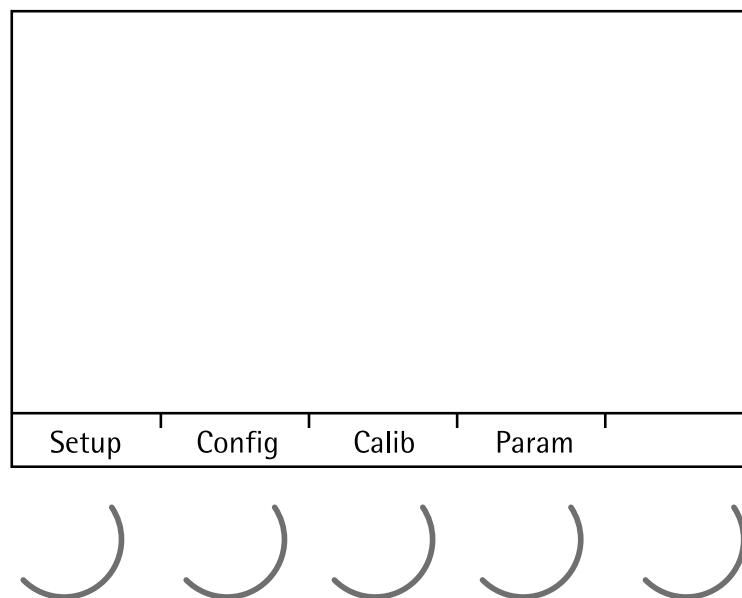

3.4.4.2 Operation using softkeys

The functions of the five softkeys  below the graphic display are indicated in the bottommost text line of the display. Softkey functions shown in gray cannot be selected at the active menu level or with the current access privileges.



In the descriptions of operating sequences which entail the use of softkeys, the softkey function to be selected is shown in square brackets; the softkey symbol is not displayed; example: [Calib].

3.4.4.3 Navigation key operation

Menu

The cursor keys, the  and  keys are used to navigate through the menus.

Parameters

Use the / cursor keys to select the individual parameters.

Use the  key to confirm the selection.

The required values | texts are entered via the alphanumeric keys.

The  key is used to check the box.

If the list of parameters is long, a vertical bar graph on the left (black and gray) shows which part of the list is displayed.

An arrow in front of a menu item indicates that there are menu sublevels.

Possible settings and an available selection list is indicated by double arrows.

The parameter is selected using the  key.

3.4.4.4 Operation using VNC

User interface, see Chapters [3.4.2](#), [3.4.3.1](#) and [3.4.4.1](#).

3.4.4.5 Operation using the front-panel keys

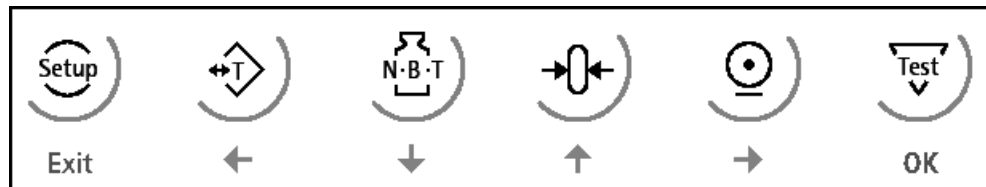

The following table shows the basic meanings of the symbols on the front-panel keys.

Indicator keys

	<p>Set tare The current gross weight is stored in the tare memory, provided that</p> <ul style="list-style-type: none"> - the weight value is stable. - the device is not in error status. <p>The key is locked during the dosing process.</p>		Starts a printout.
	<p>Switching the display Net - gross - tare The key is locked during the dosing process.</p>		<p>Depending on the settings under  - [Weighing point]- [Calib]- [Param]- [Test mode] the following is displayed by calling the Test with the key later on:</p> <ul style="list-style-type: none"> - with "Absolute" the maximum load - with "Relative" showing the deviation from the test value.
	<p>Sets gross weight to zero, provided that</p> <ul style="list-style-type: none"> - the weight value is stable. - weight is within zero setting range. <p>The key is locked during the dosing process.</p>		
Navigation/Menu Keys			
	Scroll up in the menu.		Accessing the set-up menu.
	Scroll down in the menu.	OK	<ul style="list-style-type: none"> - Confirm input/selection. - Start/restart the running dosing process.
	<ul style="list-style-type: none"> - Cursor to the left - Selection 	Exit	<ul style="list-style-type: none"> - Cancel entry/selection (after a confirmation prompt) without saving the change. - Exit parameters/menu window. - Stop/discontinue the running dosing process.
	<ul style="list-style-type: none"> - Cursor to the right - Selection 		

3.4.4.5.1 Selecting parameters

The selection and modification of parameters are described in the following.

1. Press .

▷ **SEtUP** appears on the display.

2. Press /OK.

▷ **Cd 000** appears on the display.

The "Cd" calibration menu flashes.

3. Press  to access the next parameter group.

▷ **CP** flashes on the display.

4. Press  to access the parameter number.

▷ **CP 010** appears on the display. The right digit flashes.

5. Press  to select the digits.

6. Press  to increase/decrease the number.

7. Press /OK to select the menu item.

▷ The menu item appears on the display.

8. Press /OK to switch to the parameter selection.

9. Press  to select the parameter values.

10. Press /OK to select the parameter values.

11. Press "Exit" to exit a menu.

▷ If a parameter was changed, **SAVE**

appears on the display.

12. Press /OK.

▷ **YES** appears on the display.

13. Press  if necessary, to select "no."

14. Press /OK to save the change.

3.5 Overview of connections

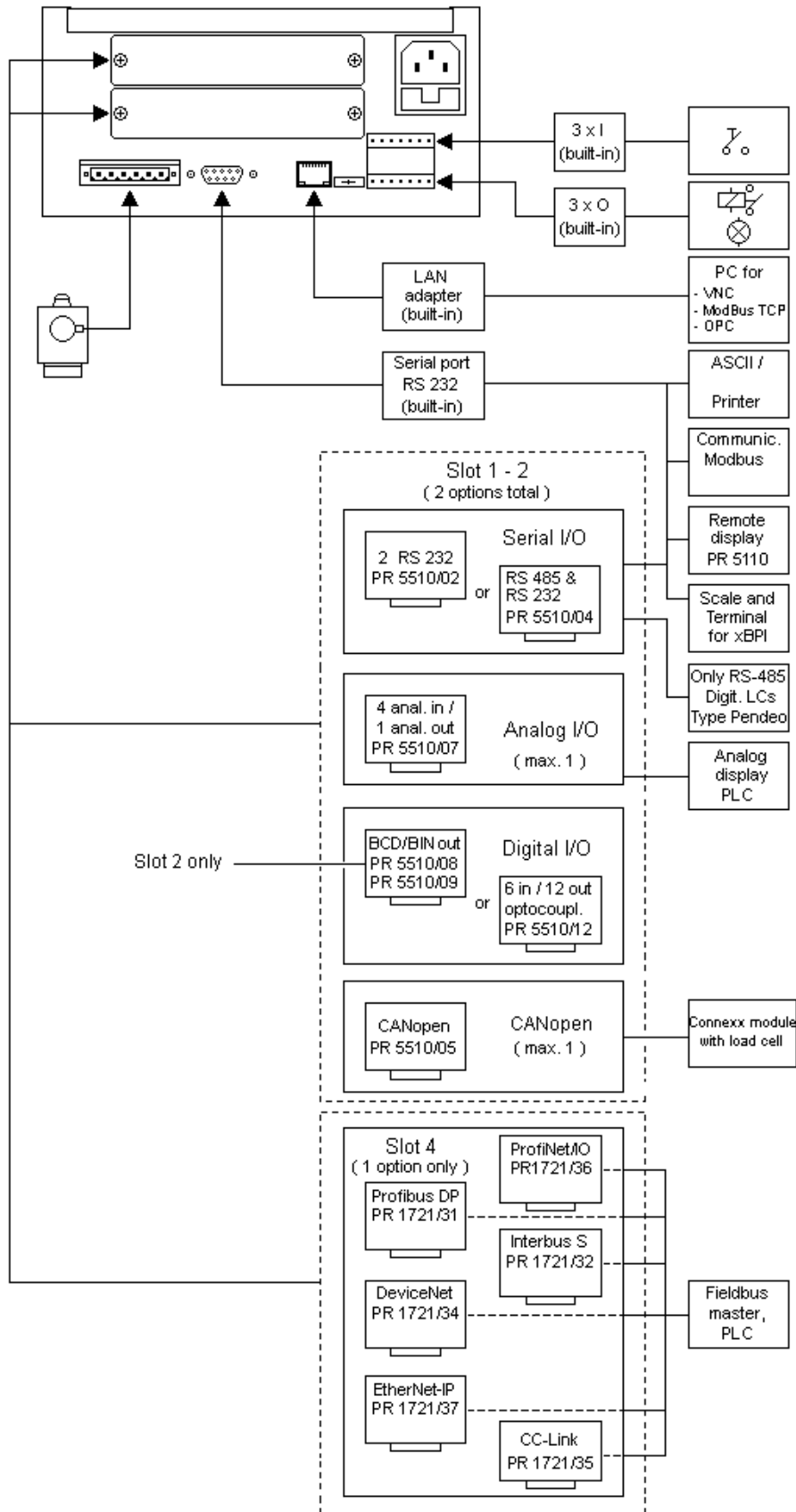

3.5.1 Plug-in cards

The main board can be fitted with max. 2 plug-in cards.

Two cards of the same type must not be plugged into slot 1 and 2 at the same time (except for PR 5510/04).

If slot 4 has a card, only one other card can be plugged into slot 1 or 2.

Product	Function	Position
PR 5510/02 2 x RS-232 serial interfaces	The interfaces can be configured by software. For more information, see Chapter 4.7.2 .	Slot 1 and/or 2
PR 5510/04 - 1 x RS-232 serial interface - 1 x RS-485/RS-422 serial interface	The interfaces can be configured by software. For more information, see Chapter 4.7.3 .	Slot 1 and/or 2
PR 5510/05 CANopen interface	For more information, see Chapter 4.7.4 .	Slot 1 or 2
PR 5510/07 Analog input and output board	Analog input: internal 14 bits binary = 20,000 counts, @ e.g. 0...20 mA/0...10 V Analog output: internal 16 bits = 65,536 counts, resolution of 20,000 @ 20 mA For more information, see Chapter 4.7.6 .	Slot 1 or 2
PR 5510/08 BCD output (open emitter)	Outputs: 5 digits BCD + preceding sign or 3 bytes binary Input: 1 bit (DATA IN) For more information, see Chapter 4.7.7 .	Slot 2
PR 5510/09 BCD output (open collector)	Outputs: 5 digits BCD + preceding sign or 3 bytes binary Input: 1 bit (DATA IN) For more information, see Chapter 4.7.8 .	Slot 2
PR 5510/12 - 6 digital inputs - 12 digital outputs	6 passive opto-decoupled inputs 12 passive opto-decoupled outputs The interfaces can be configured by software. For more information, see Chapter 4.7.11 .	Slot 1 or 2

Product	Function	Position
PR 1721/31 ProfiBus DP	ProfiBus DP slave acc. to IEC 61158 with max. 12 Mbit/s For more information, see Chapter 4.7.13 .	Slot 4
PR 1721/32 InterBus-S	InterBus-S slave with max. 500 kbit/s For more information, see Chapter 4.7.14 .	Slot 4
PR 1721/34 DeviceNet	DeviceNet slave with max. 500 kbit/s For more information, see Chapter 4.7.15 .	Slot 4
PR 1721/35 CC-Link	CC-Link with max. 10 Mbit/s For more information, see Chapter 4.7.16 .	Slot 4
PR 1721/36 ProfiNet I/O	ProfiNet I/O with 10/100 Mbit/s For more information, see Chapter 4.7.17 .	Slot 4
PR 1721/37 EtherNet IP	EtherNet IP with 10/100 Mbit/s For more information, see Chapter 4.7.18 .	Slot 4

4 Device installation

4.1 General notes

Before starting work, please read Chapter 2 and follow all instructions.

⚠ WARNING

Warning of hazardous area and/or personal injury

- ▶ All cable connections must be protected from damage.

Note:

- Measurement cables should be kept away from power equipment.
- Signal cables and measurement cables should be installed separately from electric power lines.
- It is recommended that measurement cables are laid in separate cable conduits.
- Power cables should be crossed at right angles.

Further procedures:

- Check the consignment: make sure that all components are present.
- Safety check: inspect all components for damage.
- Make sure that the on-site installation is correct and complete including cables, e.g. power cable fuse protection, load cells, junction box, data cables, console/cabinet, etc.
- If necessary, install the plug-in cards (device must be disconnected from all voltage sources).
- Follow all device installation instructions related to application, safety, ventilation, sealing and environmental influences.
- Connect the cable from the junction box or platform/load cell.
- If applicable: connect other data cables, network cables, etc.
- Connect to supply voltage.
- Check the installation.

4.2 Mechanical preparation

Have all required parts, technical documents, and tools at hand for control cabinet installation.

Other procedure:

- Make the control panel cut-out for the device in the control cabinet door, for example; see Chapter [3.3.3](#).
- Install the device, see Chapter [4.3](#).
- Secure the cable at the place of installation, e.g. using cable ties.
- Remove the insulation from the cable ends and keep the strands short.

- Connect the screens.
- Establish grounding/equipotential bonding between devices/system components.

4.3 Installing the device

Note:

The composition of the switch cabinet door must be suitable for the intended installation.

The rigidity and surface texture must allow even pressing of the gasket during installation.

Alternatively, suitable mechanical reinforcement should be provided in order to optimize the distribution of force.

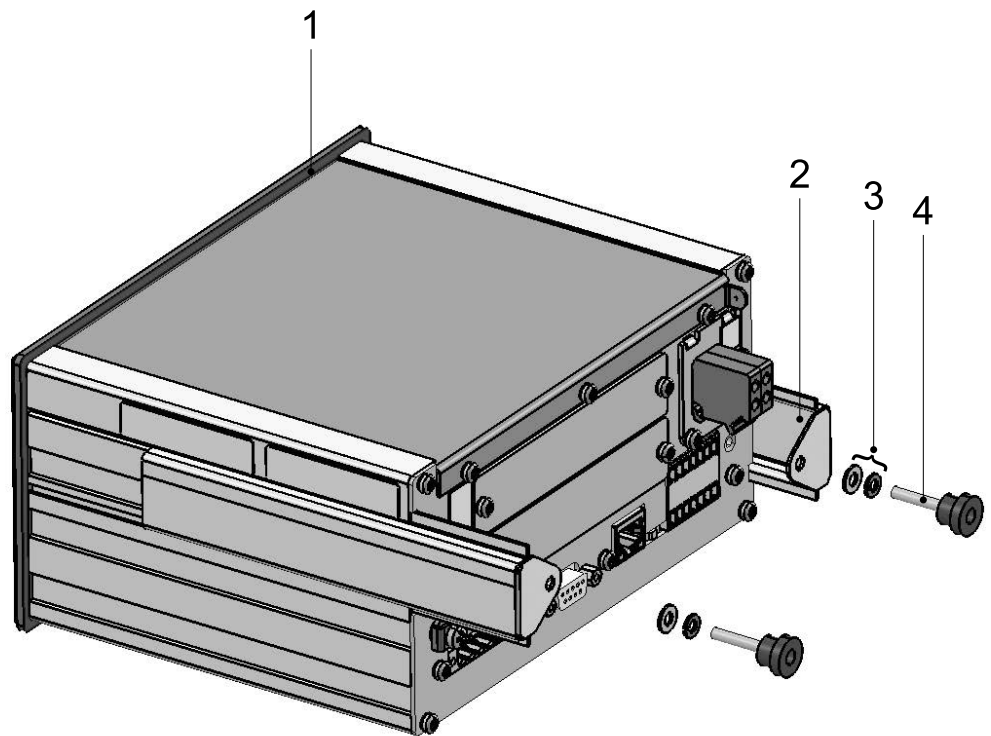

1. Loosen the screws (4) and remove them together with the washers (3).
2. Remove the retaining brackets (2).
3. Slide the supplied gasket (1) over the indicator from the rear and fit it tightly against the front.
4. Slide the indicator with the gasket fitted through the panel cut-out from the front.
5. Reinsert the two retaining brackets (2) into the device side walls and push against the inside of the panel.
6. Screw each the screws (4) with washers (3) a few revolutions into the threaded holes on the device back wall, until the device sits loosely in the panel cut-out.
7. Position the device centrally in the panel cut-out.
8. Alternately tighten each of the screws (4) securely. While doing so, keep checking the position of the device in the panel cut-out and adjust if necessary.

4.4 EMC-compliant installation

4.4.1 Connecting the screens

The screen for the D-Sub connector must be connected as described in Chapter [4.7.1.2](#).

The screens for the connecting cable/load cell cable must be connected to the grounding terminal on the back of the device.

4.4.2 Connecting the equipotential bonding conductor

The equipotential bonding conductor must be connected to the grounding terminal on the back of the device.

4.5 Hardware construction

The overall electronics is installed on the following units:

- Mainboard
- Display board

4.5.1 Main board

The main board provides the slots for the

- Interface cards (accessories; see Chapter [4.7](#))
- Fieldbus card (accessories; see Chapter [4.7](#))

The lithium battery (5, under the cover for the power supply) is always activated and powers the calendar/clock module.

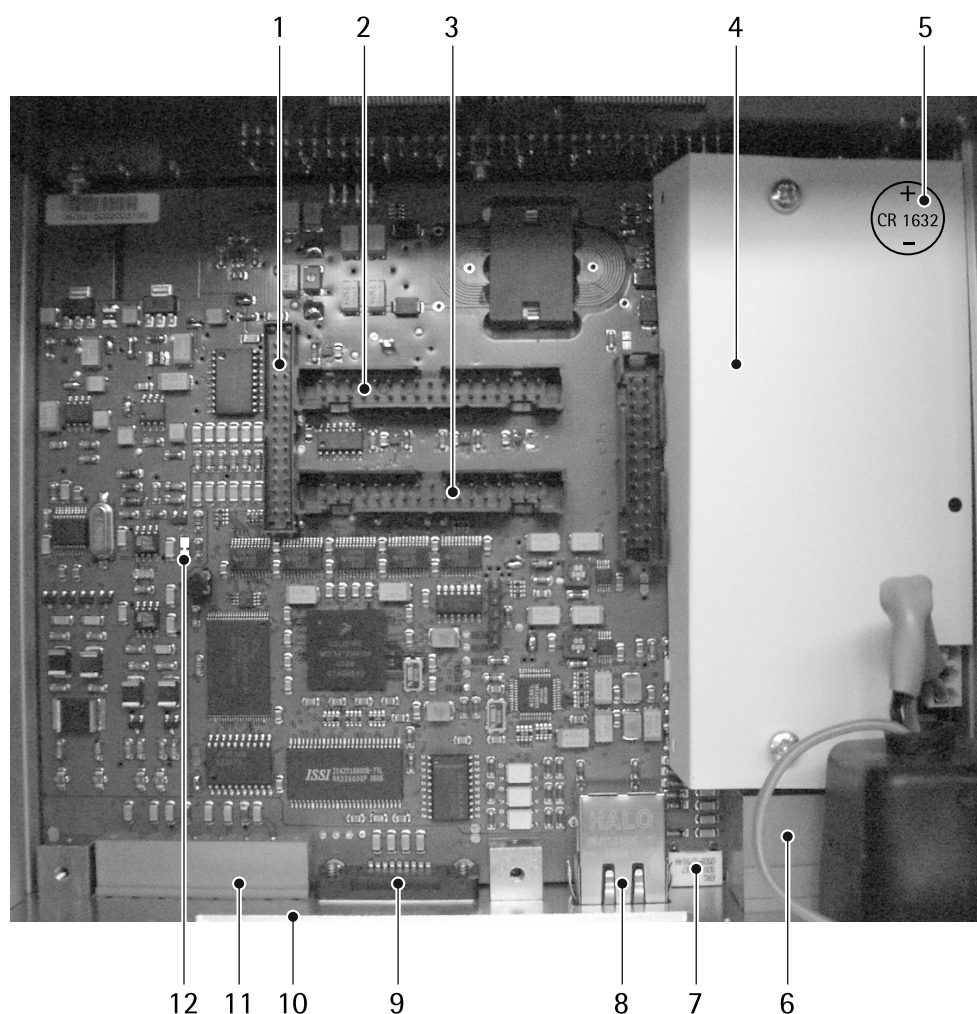

No.	Description
1	Slot 4: Slot for fieldbus card
2	Slot 1: Slot for interface card
3	Slot 2: Slot for interface card
4	Power supply (under the cover)
5	Lithium battery (under the cover for the power supply)
6	Digital inputs and outputs
7	CAL switch
8	Ethernet port
9	RS-232 serial interface
10	Display board
11	Load cell connection
12	Solder bridge

4.5.2 Display board

The display board is connected to the main board by a plug.

4.5.3 Network port

The device has an internal Ethernet port.

NOTICE

Damaged data will bring a stop to IT operations.

Protect the IT network to prevent unauthorized access.

- ▶ The current IT security guidelines must be followed so as to minimize the risks.

4.5.3.1 Ethernet port

The Ethernet port contains a powerful TCP/IP interface connection with transfer rates of 10 or 100 Mbit/s.

Function tests can be performed via the LEDs (green and yellow) in the RJ-45 socket.

Technical data

Description	Data
Connection 	RJ-45 socket on the device back Green (grn): flashing on data traffic (activity) Yellow (yel): lights up when there is an existing connection (link)
Transfer rate	10 Mbit/s, 100 Mbit/s, full/half duplex, auto-detection
Connection mode	Point to point
Potential isolation	Yes
Cable type	CAT 5 patch cable, twisted pair, screened
Cable impedance	150 Ω
Cable length	Max. 115 m

4.5.3.2 Notebook/PC connection

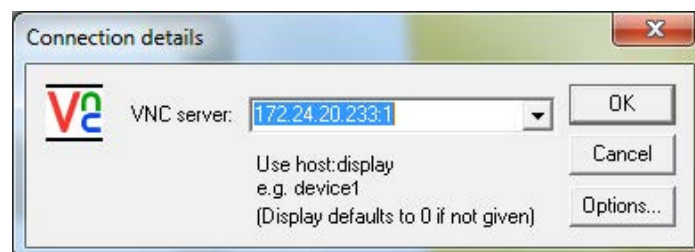

Remote operation of the device from a notebook/PC is possible (install VNC software version 3.3.7* on the notebook/PC).

For the network address, see Chapter [7.9](#).

* Minebea Intec guarantees the functionality only if this version is used.

4.5.4 RS-232 interface

The device is equipped with an integrated RS-232 interface.

This interface is configurable, and can be used, for example, for data transmission to a remote display or printer.

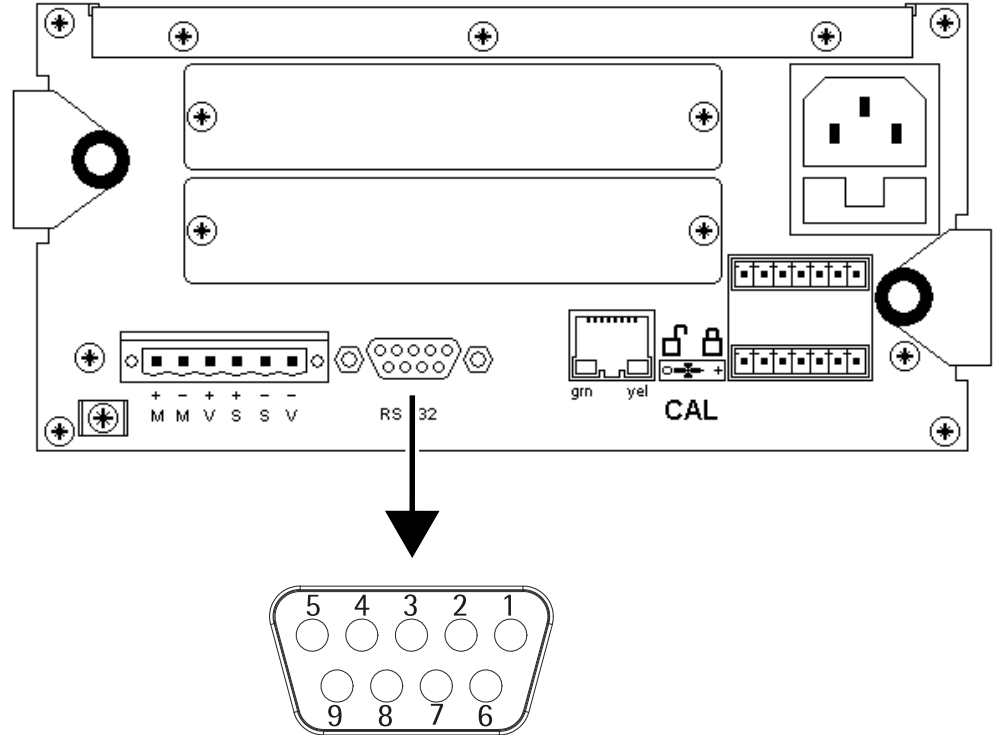

Technical data

Description	Data
Connection	D-Sub female connector, 9-pin
Number of channels	1
Type	RS-232, full duplex
Transmission rate [bit/s]	300 to 115K2 bit/s
Parity	even
Data bits	7/8 7
Input signal level	Logic 1 (high) -3 to -15 V Logic 0 (low) +3 to +15 V
Output signal level	Logic 1 (high) -5 to -15 V Logic 0 (low) +5 to +15 V
Number of signals	Input: RxD, CTS Output: TxD, RTS
Potential isolation	None
Cable type	Twisted pair, screened (e.g., LiFYCY 3x2x0.20), 1 pair of wires for ground (GND)

Description	Data
Cable gauge	1.5 mm ²
Cable length	Max.15 m

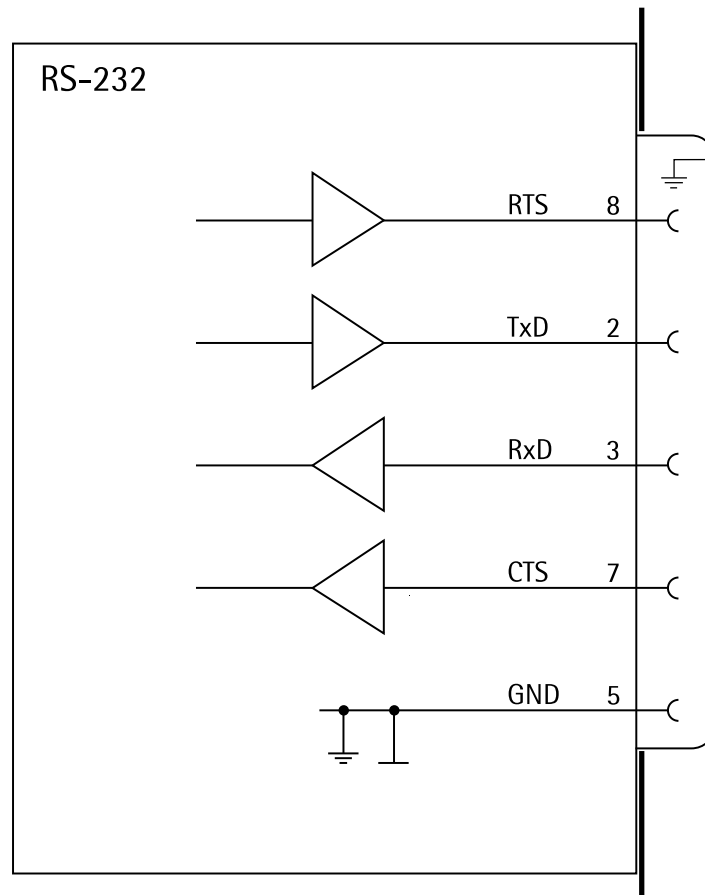
Block diagram RS-232**Note:**

After 30 seconds without data exchange, RTS and TxD are switched off.

4.5.4.1 Connecting a YDP14IS ticket printer

The YDP14IS-OCEUV ticket printer can be connected via the internal RS-232 interface or the PR 5510/02 card or the PR 5510/04 card.

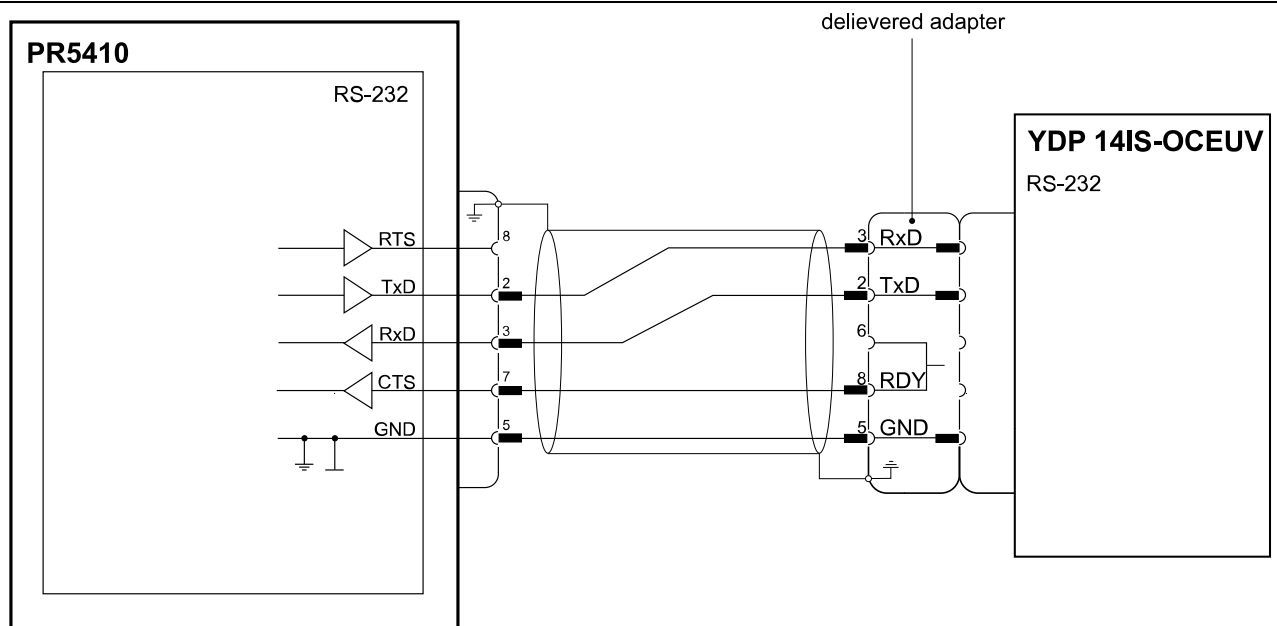

Configuration PR 5410

 - [Serial ports parameters] - [Printer] - [Built-in RS-232] - [Param] :

- [Protocol] to "RTS/CTS"
- [Baudrate] to "9600"
- [Bits] to "8"
- [Parity] to "none"
- [Stop bits] to "1"
- [Output mode] to "Raw"

Printer configuration

The printer must be set to "Line Mode" (the factory setting is Page Mode). Press the "FEED" key to switch from one to the other.

The procedure can be found in the printer operating instructions.

4.5.4.2 Connecting an IS platform

One IS platform scale with xBPI or SBI protocol can be connected via the internal RS-232 interface or the PR 5510/02 card or the PR 5510/04 card.

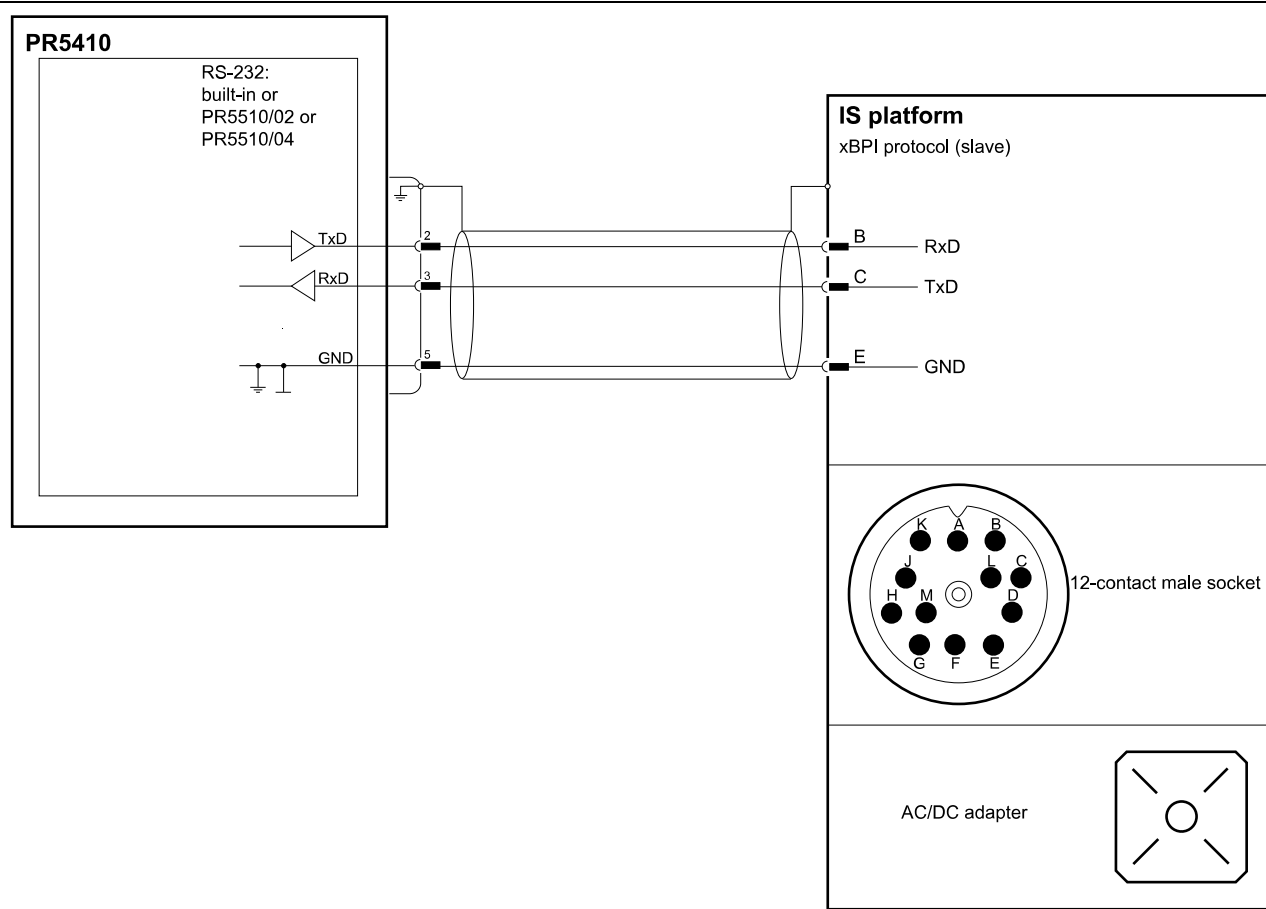

Configuration PR 5410

 - [Serial ports parameters] - [xBPI port] - [Built-in RS-232]

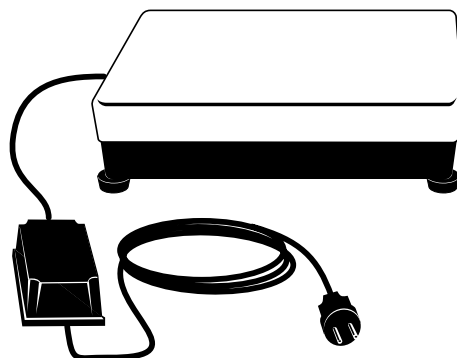

Note:

For further information, see the platform scale operating instructions.

4.5.5 Digital inputs

The main board is equipped with 3 digital inputs for the process control. They are electrically isolated by optocouplers and each 2-pin potential-free.

The interface can be configured by software.

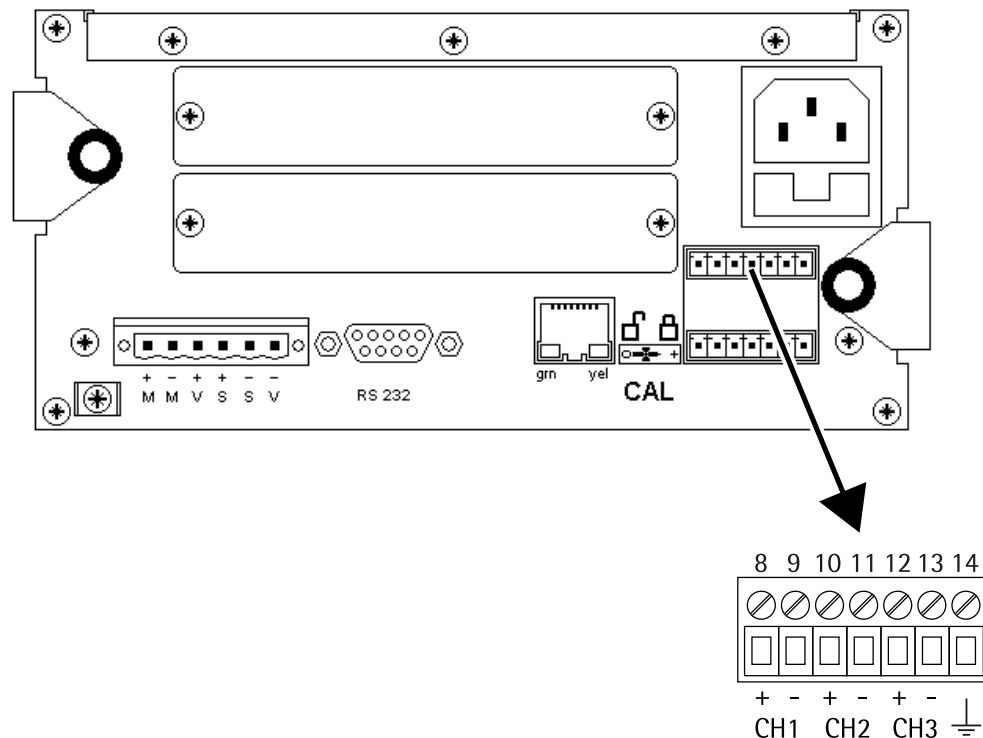

Technical data

Description	Data
Connection	Terminal, 7-pin
Number of inputs	3 (CH1, CH2, CH3)
Input voltage	Logic 0: $U_{DC} = 0$ to 5 V or open Logic 1: $U_{DC} = 10$ to 28 V Passive, external power supply required.
Input current	≤ 11 mA @ $U_{DC} = 24$ V ≤ 5 mA @ $U_{DC} = 12$ V Protection against incorrect polarity.
Potential isolation	Via optocoupler.
Cables	Screened Connect cable screen (wire gauge max. 1.5 mm ²) to the terminal (terminal contact 14; see example).
Cable length	Max. 50 m

Example:

Contact input "passive"

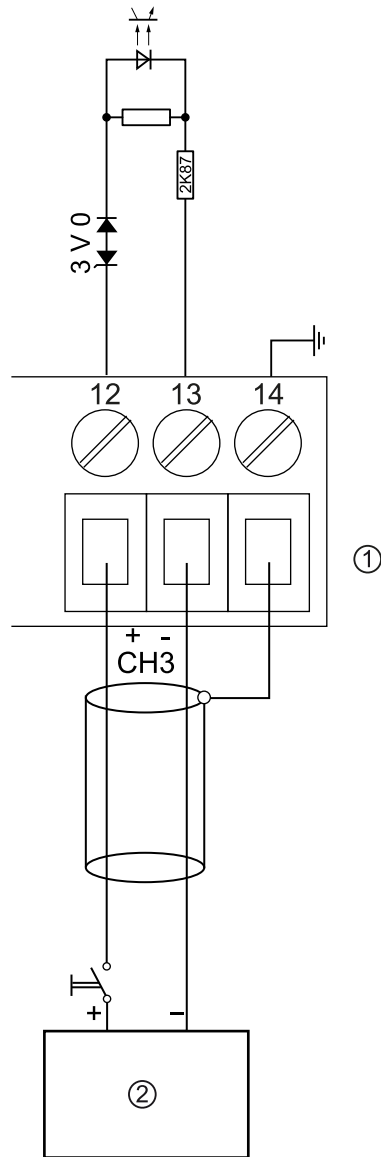

① Digital inputs

② Supply unit $U_{DC} = 24\text{ V } 0.5\text{ A}$

4.5.6 Digital outputs

The main board is equipped with 3 digital outputs for the process control. They are electrically isolated by optocouplers and each 2-pin potential-free.

The interface can be configured by software.

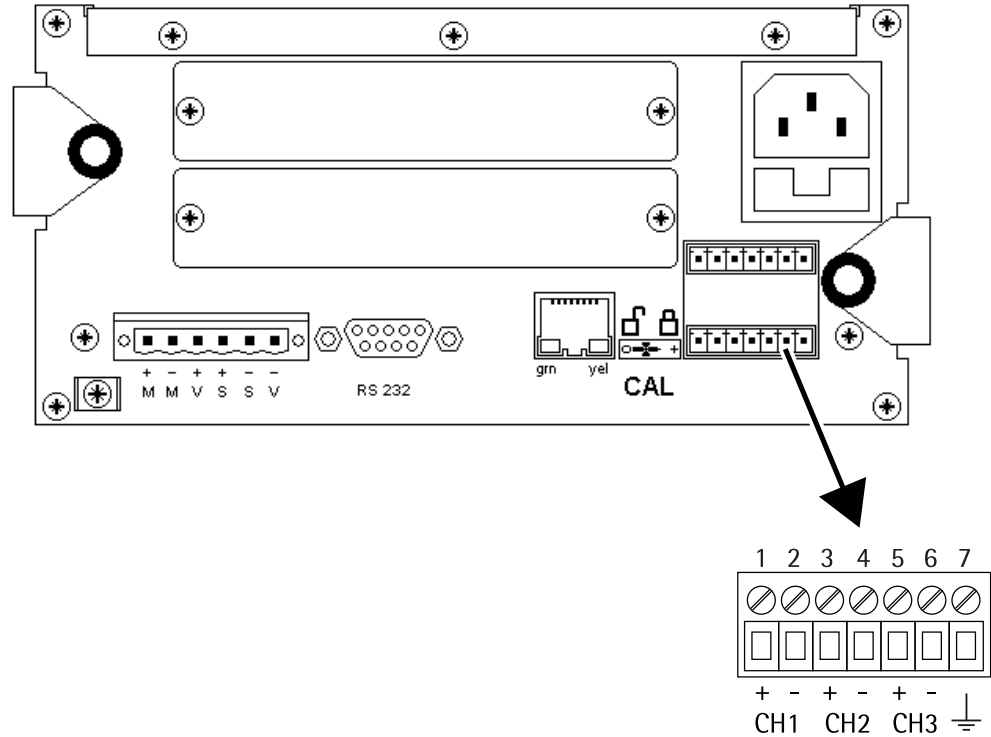

Technical data

Description	Data
Connection	Terminal, 7-pin
Number of outputs	3 (CH1, CH2, CH3)
Max. switching voltage	$U_{DC} = 31\text{ V}$ Protection against incorrect polarity.
Max. switching current	25 mA Voltage drop @ 25 mA: 3 V Passive, external power supply required.
Potential isolation	Via optocoupler.
Cables	Screened Connect cable screen (wire gauge max. 1.5 mm ²) to the terminal (terminal contact 7; see example).
Cable length	Max. 50 m

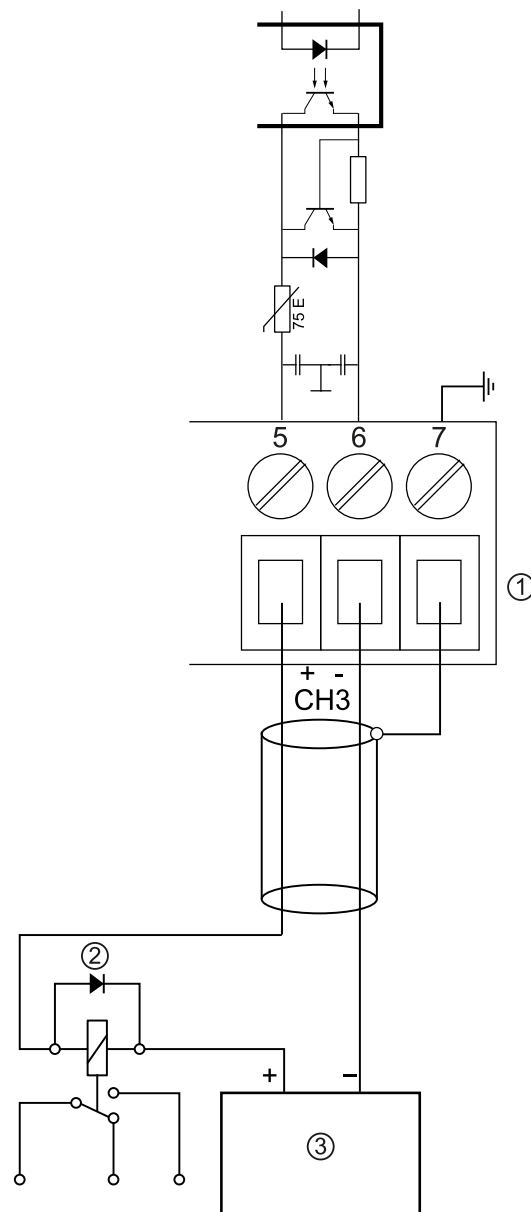
Example:**Relay control (power output)**

- ① Digital outputs
- ② Inductive load for free-wheel diode
- ③ Supply unit $U_{DC} = 24\text{ V } 0.5\text{ A}$

The relay switches when the output is active (true).

To protect the output circuit, relays must be equipped with free-wheel diodes.

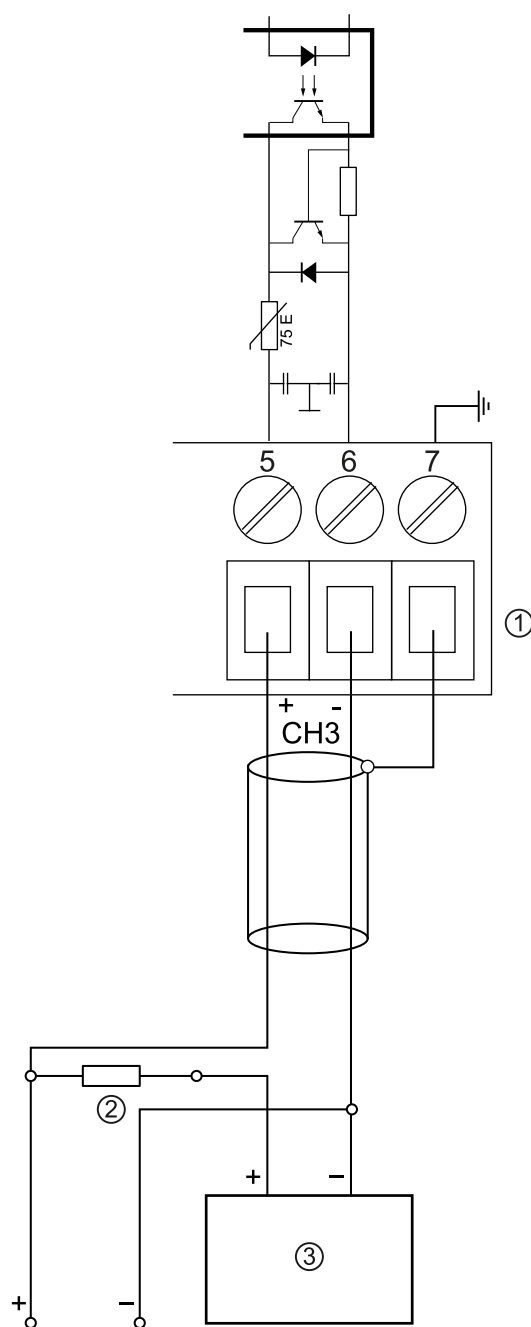
Example:**Voltage output**

① Digital outputs

② The load resistance must be 2.2/1 kΩ.

③ Supply unit $U_{DC} = 24\text{ V } 0.5\text{ A}$

When the output is active (true), the output voltage drops from $U_{DC} = 24/U_{DC} = 12\text{ V}$ to $U_{DC} < 3\text{ V}$.

4.6 Connecting analog load cells and platforms

4.6.1 General information

Load cells or analog platforms (e.g. from the CAPP series) can be connected.
The supply voltage is protected against short circuit and overload.

Note:

The colors listed here apply for the Minebea Intec load cell and connection cables of type "PR ..."

Color code

bk	=	Black
bu	=	Blue
gn	=	Green
gy	=	Gray
rd	=	Red
wh	=	White

For additional information on the connection of load cells and cable junction boxes, refer to the corresponding installation manuals.

4.6.2 Connecting a load cell with a 4-wire cable

The following links between the terminal contacts are provided:

- ① from Sense S+ to Supply V+
- ② from Sense S- to Supply V-

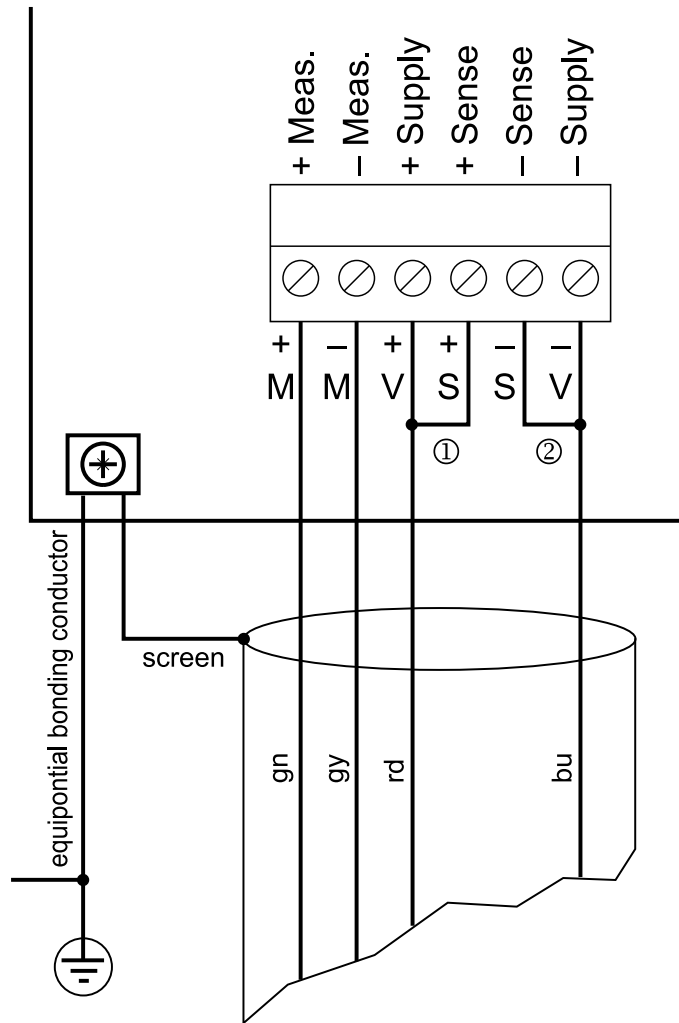

Terminal	Connection/color code	Description
M+	+ Meas./gn	+ Measuring voltage (load cell output)
M-	- Meas./gy	- Measuring voltage (load cell output)
S+	+ Sense	+ Sense voltage
S-	- Sense	- Sense voltage
V+	+ Supply/rd	+ Supply voltage
V-	- Supply/bu	- Supply voltage
Housing	Ground (GND)	Screen (ground)

4.6.3 Connecting a load cell with a 6-wire cable

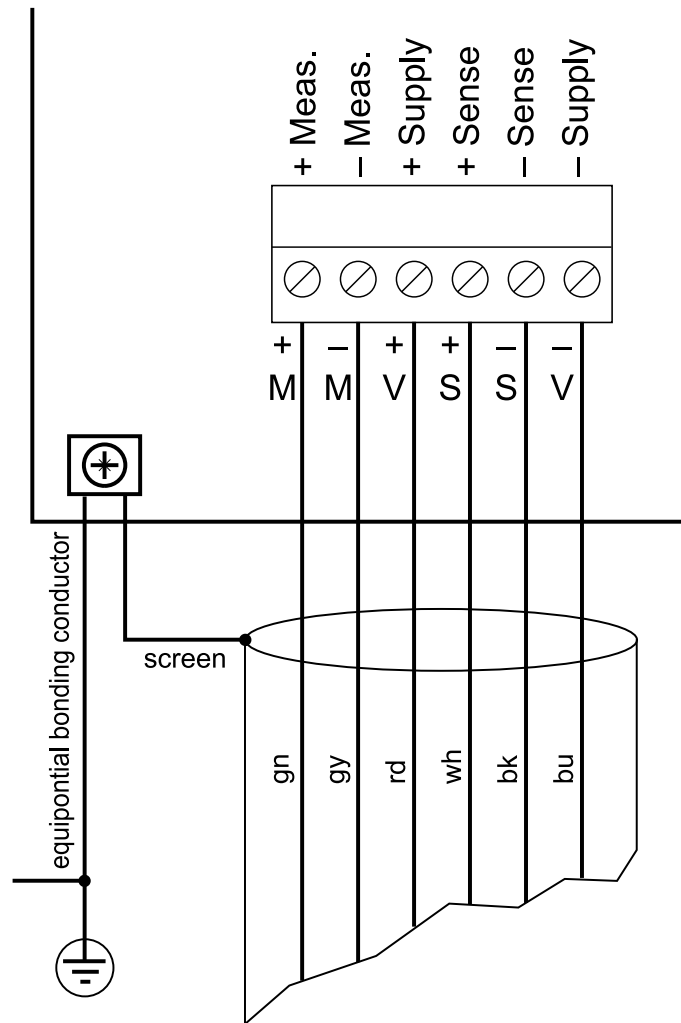

Terminal	Connection/color code	Description
M+	+ Meas./gn	+ Measuring voltage (load cell output)
M-	- Meas./gy	- Measuring voltage (load cell output)
S+	+ Sense/wh	+ Sense voltage
S-	- Sense/bk	- Sense voltage
V+	+ Supply/rd	+ Supply voltage
V-	- Supply/bu	- Supply voltage
Housing	Ground (GND)	Screen (ground)

4.6.4 Connecting between 2 and 8 load cells (650 Ω) using a 6-wire connection cable

Connections are made via cable junction box PR 6130/.. using connection cable PR 6135/.. or PR 6136/... .

Load cell supply circuit

- Load resistance of load cell circuit $\geq 75 \Omega$, e.g., 8 load cells of 650 Ω each
- The supply voltage is fixed at $U_{DC} = 12 \text{ V}$ and protected against short circuits.

For further technical data, see Chapter [17.5.1](#).

Note:

If hum interference occurs, the cable screens should only be connected on one side.

Depending on the design of the cable junction box used, either the jumper J3 must be removed or the cable screens must be disconnected from the terminal contacts highlighted in yellow.

Connection example

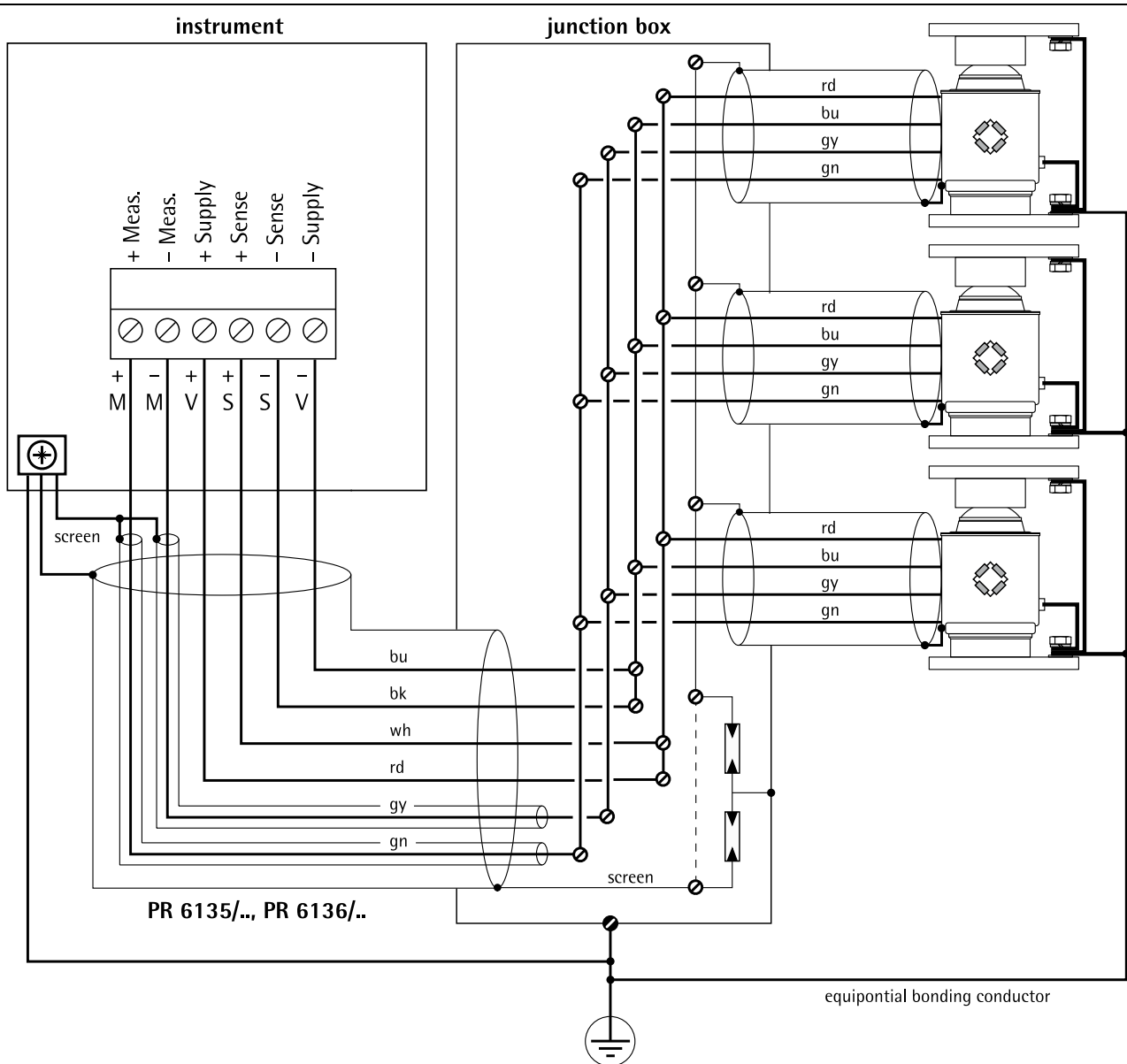

4.6.5 Connecting load cells of type series PR 6221

See installation manuals of PR 6221 and PR 6021/08, ../18, ../68S.

4.6.6 Testing the measuring circuit

A simple test with the load cells connected can be carried out with a multimeter.

Note:

In the case of an external load cell supply voltage or use of an isolating unit, the internal load cell supply is not relevant.

Measuring voltage

0–12 mV = @ LC with 1.0 mV/V
 0–24 mV = @ LC with 2.0 mV/V

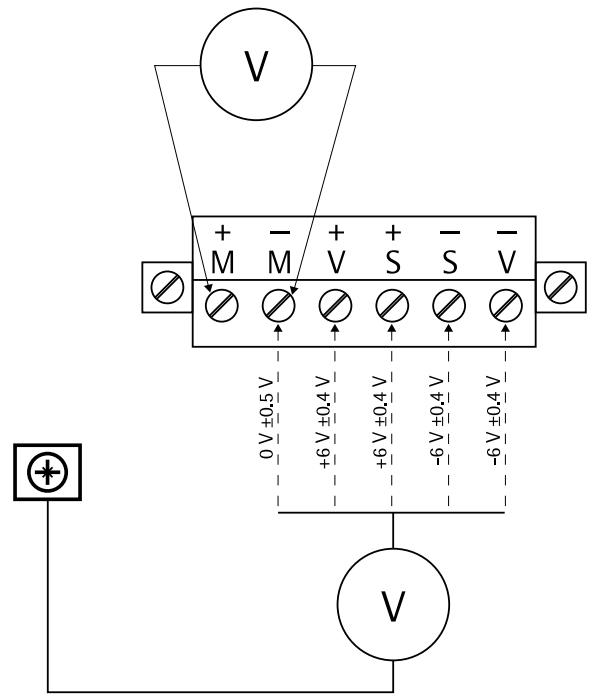

4.6.7 External supply to load cells

If the total resistance of the load cells is $\leq 75 \Omega$ (e.g., more than 4 load cells with 350Ω), an external load cell supply is required. In this case, the internal supply is replaced by a potential-free external supply.

The center of the external supply voltage (0 ext. supply) should be connected to the device housing to ensure that the voltage reacts symmetrically to 0.

The internal supply is not connected.

If the external supply $U_{DC} < 8 V (\pm 4 V)$, a solder bridge (closed when delivered) must be opened on the main board (see Chapter 4.6.8) to reduce the sense voltage U_{DC} to below approx. $\pm 4 V$.

Connection example

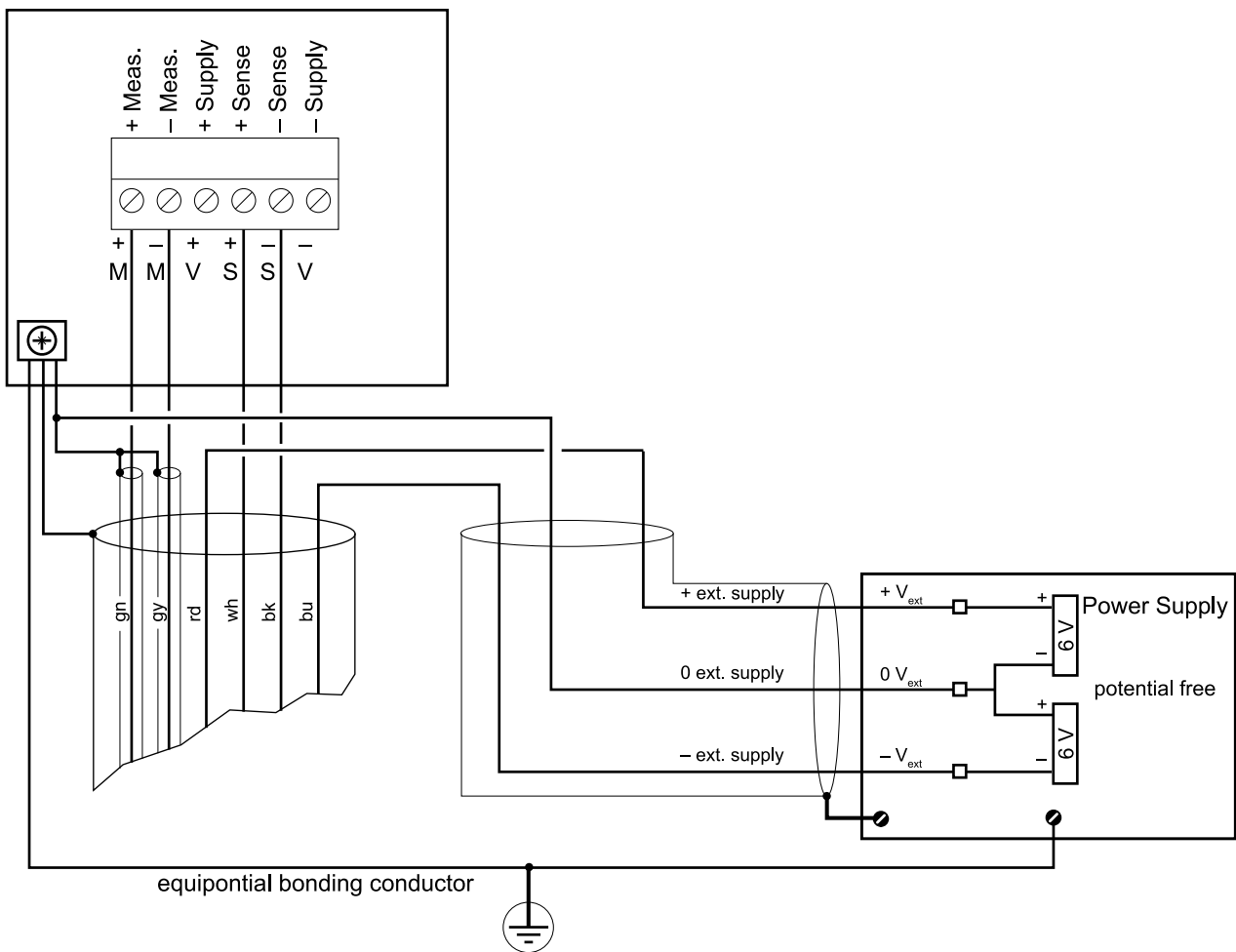

4.6.8 Connection to relay PR 1626/6x

The connection is made via the connecting cable PR 6135/..

The internal load cell power supply (V+, V-) of the PR 5410 must **not** be connected.

Note:

Other connections are described in the PR 1626/6x instrument manual.

If PR 1626/61 ($U_{DC} = 7,5 \text{ V}$) is connected, the solder jumper (12) on the PR 5410 mainboard should be opened (see Chapter [4.5.1](#)). The sense voltage detection is now switched.

NOTICE**Installation in the Ex zone**

- ▶ The screen of the load cell cable and the screen of the connecting cable must not be connected inside the junction box, if connection of both ends is not permissible according to the regulations for installation in the ex-zone.

Connection example

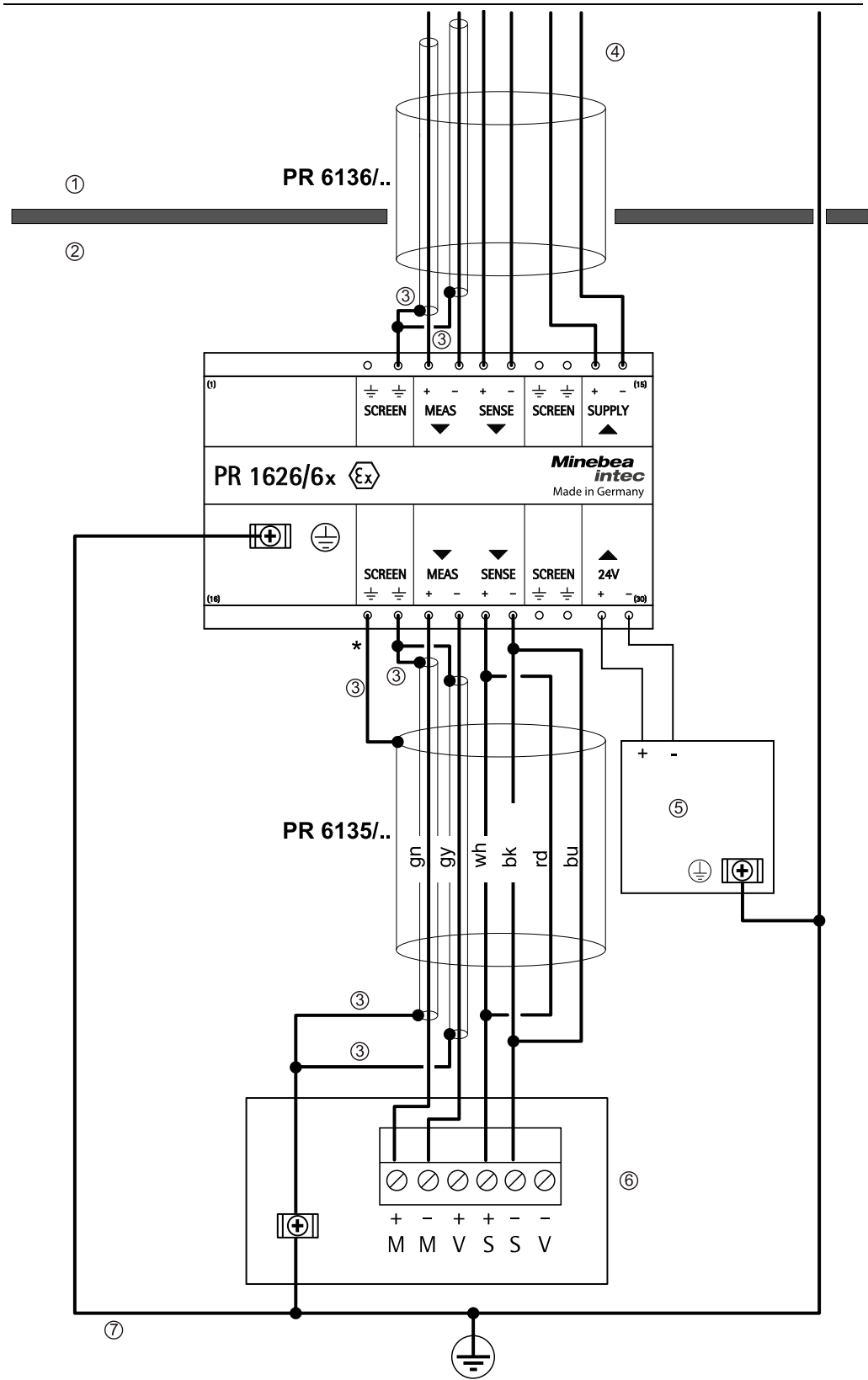

- ① Ex-zone
- ② no Ex-zone (secure area)

- ③ Screen
- ④ Cable junction box
- ⑤ External power supply SELV $U_{DC} = 24\text{ V}$
- ⑥ Indicator
- ⑦ Equipotential bonding conductor

NOTICE

Metrological problems may occur.

- ▶ Make sure there is equipotential bonding between PR 1626/6x and PR 5410.

4.6.9 Connecting an analog weighing platform (CAP... series)

You can connect an analog weighing platform to the device.

NOTICE

The cable colors shown here are valid, for example, for a CAPP4 500 x 400 and a CAPP1 320 x 420.

- ▶ The assignments of cable colors are listed in the relevant weighing platform operating instructions.

Connection designations

Combics 1 to 3 devices	PR 5410
BR_POS	V+ Supply
SENSE_POS	S+ Sense
OUT_POS	M+ Meas.
OUT_NEG	M- Meas.
SENSE_NEG	S- Sense
BR_NEG	V- Supply

The cable screens must be connected to the grounding terminal of the device. If the measuring lines (+M, -M) are screened individually, these screens must be connected to the grounding terminal as well (see also Chapter [4.4](#)).

Example:

Platform with 4-wire connection

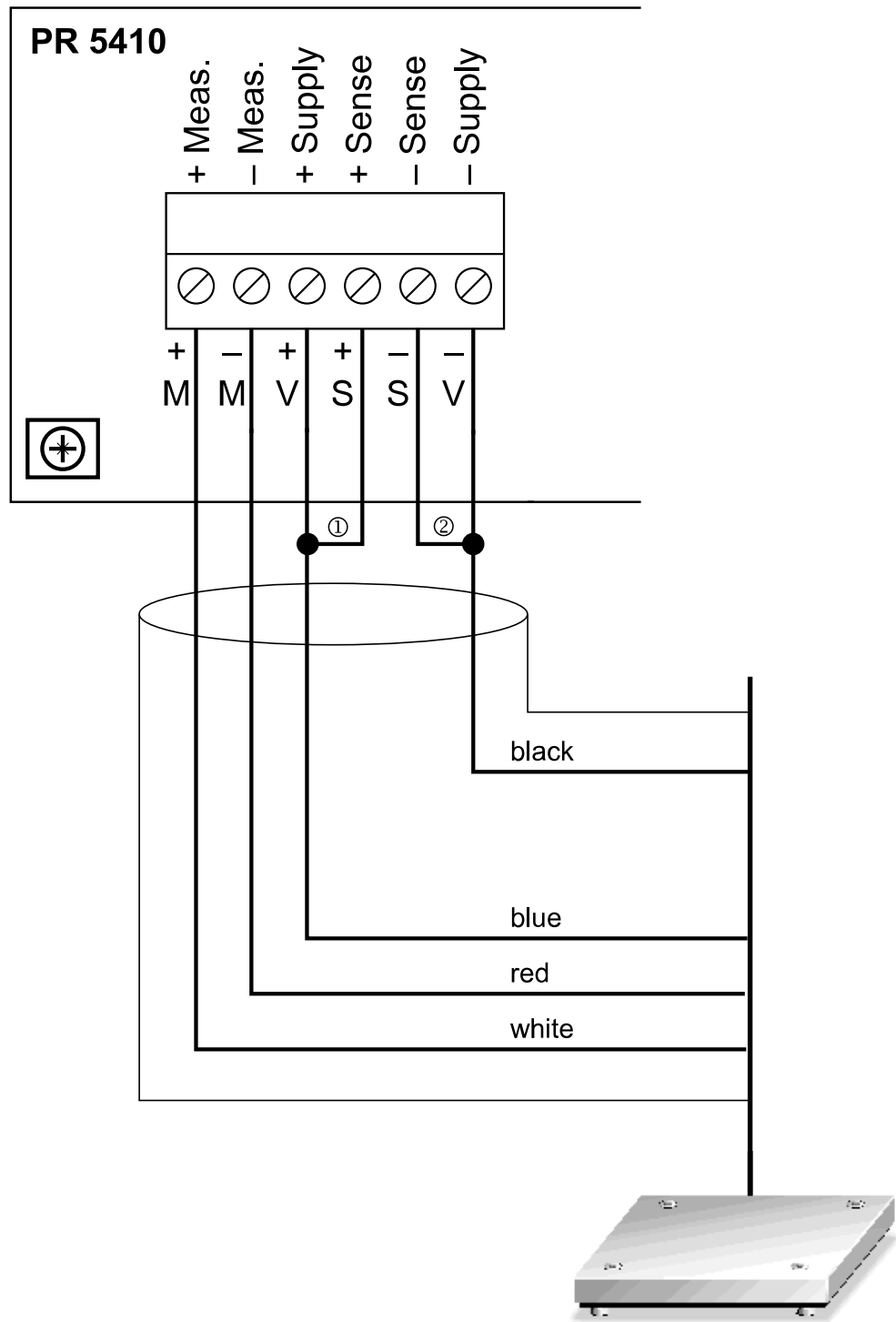

The following links between the terminal contacts are provided:

- ① from Sense S+ to Supply V+
- ② from Sense S- to Supply V-

Example:

Platform with 6-wire connection

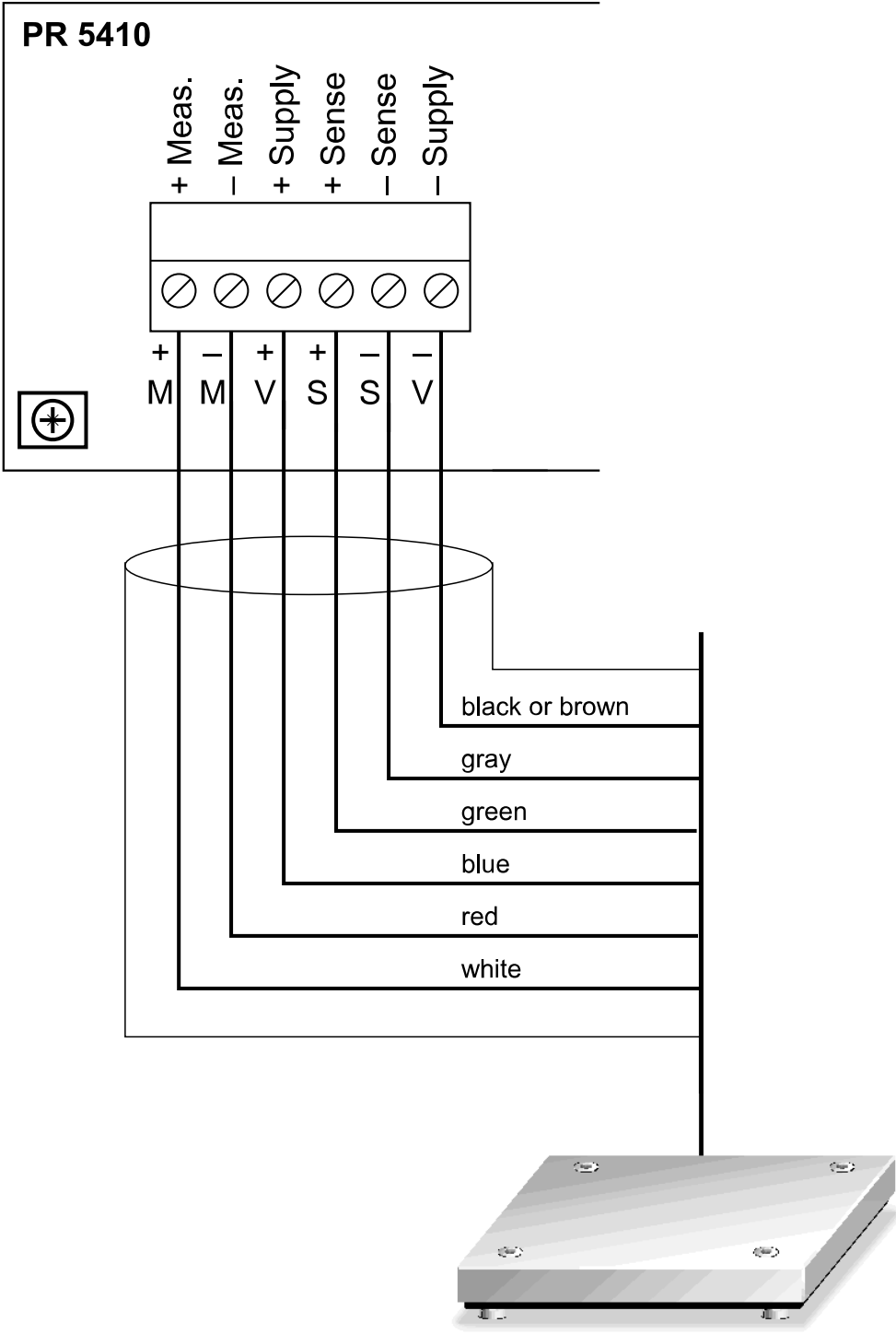

4.7 Accessories

4.7.1 General information

The main board has three additional function-specific slots. These slots can accommodate the following cards:

- "Slot 1" and "slot 2": PR 5510/02 (see Chapter [4.7.2](#)), PR 5510/04 (see Chapter [4.7.3](#)), PR 5510/05 (see Chapter [4.7.4](#)), PR 5510/07 (see Chapter [4.7.6](#)), PR 5510/12 (see Chapter [4.7.11](#))
- "Slot 2": PR 5510/08 (see Chapter [4.7.7](#)), PR 5510/09 (see Chapter [4.7.8](#))
- "Slot 4": PR 1721/3x fieldbus card (see Chapter [4.7.13](#), [4.7.14](#), [4.7.15](#), [4.7.16](#), [4.7.17](#), [4.7.18](#))

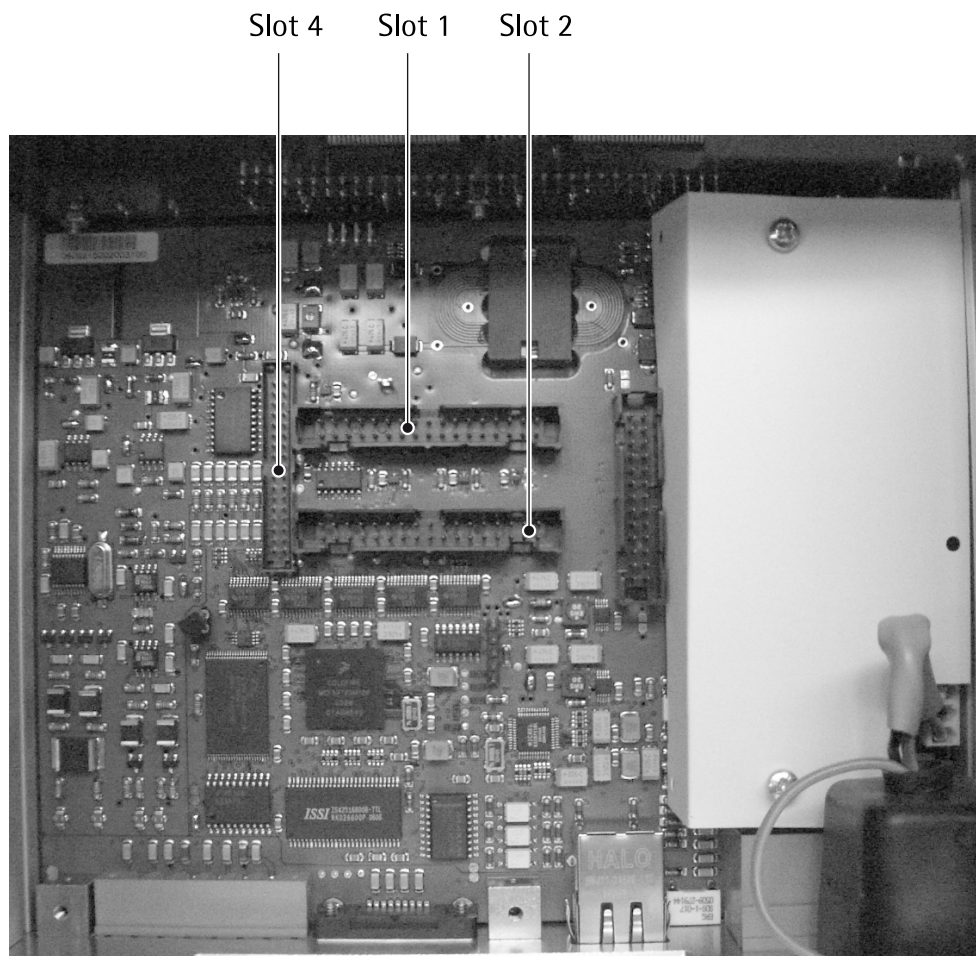

⚠ WARNING

Working on the device while it is switched on may have life-threatening consequences.

- Before installing or removing a plug-in card, the device must be disconnected from all voltage sources.

Note:

After installation/modification, the plug-in cards are detected automatically.

The installed plug-in cards can be displayed via  - [Show HW-Slots]; see Chapter [7.19.3](#).

4.7.1.1 Installing plug-in cards

Note:

The ribbon cables are plugged into the ports (slot 1...2, 4) on the main board.

The cables are coded to protect against incorrect polarity.

A maximum of 2 cards can be mounted. Accordingly, there are two openings in the back panel for the card support plates.

Procedure:

1. Open the device (see Chapter [2.4.2](#)).
2. Remove the corresponding dummy plates on the rear panel (2× M3) and replace them with the support plates for the plug-in cards.
3. Insert the ribbon cables into the appropriate ports on the main board.
4. Close the device again.

4.7.1.2 Installation of a cable in the D-sub connector

The connections on the back wall are plugs. The wires must be kept as short as possible leading to the terminals. The plug housings are conductive (metallic) and thus also part of the screen. They must be screwed correctly to the back wall.

NOTICE

Material damage is possible.

- The cable screen must be connected to the metal housing on both ends of the cable.
-

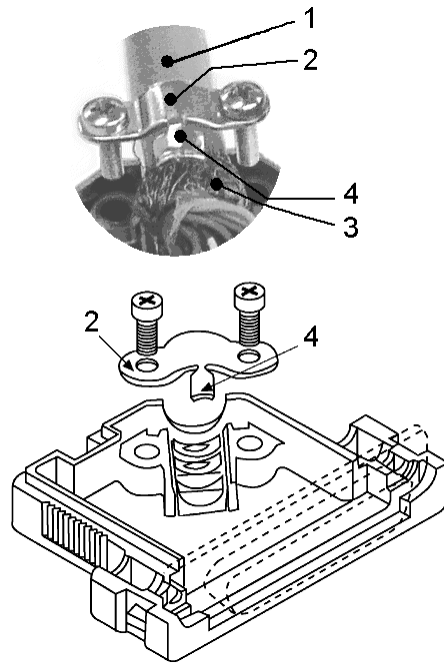
**Procedure:**

1. Open the plug housing (stop clamps).
2. Loosen and open the cable clamp (2).
3. Remove approx. 50-60 mm of insulation from the cable.
4. Cut back the cable screen (3) up to 5 mm and bend back over the cable mantle (1).
5. Remove the insulation of the cable strands 3 mm and solder.
6. Insert pin housing.
7. Lay cable under the cable clamp (2).
 - ▷ Grounding tab (4) presses on the surrounding cable screen (3) and the cable clamp (2) presses on the cable mantle (1).
8. Close and tighten the cable clamp (2).
9. Check the strain relief.
10. Close the plug housing (stop clamps).

4.7.2 2x RS-232-interface

The RS-232 interface card has the type designation PR 5510/02.

The plug-in card has two RS-232 channels (A and B) which can be used simultaneously and independently from each other.

Up to two PR 5510/02 cards can be plugged into "Slot 1" and "Slot 2."

These interfaces are configurable, and can be used, for example, for data transmission to a remote display or printer.

The RS-232 interface can only be used as a point-to-point connection.

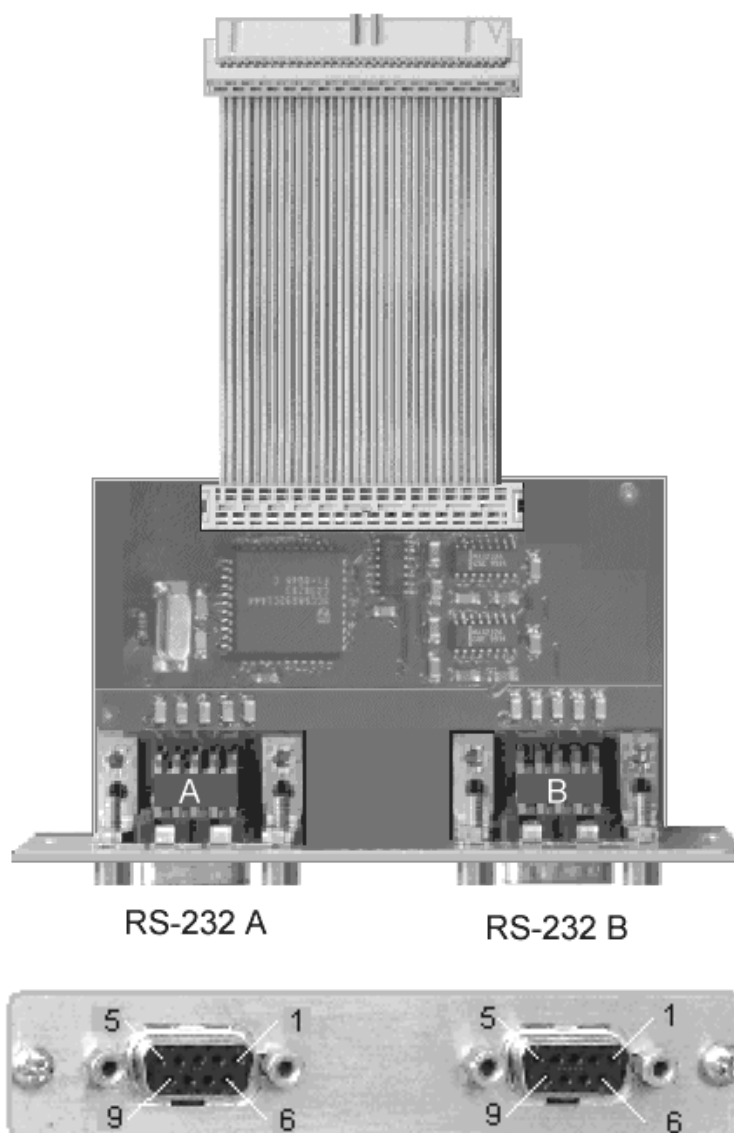

Specifications

Description	Data
Connection	2x D-Sub female connector, 9-pin
Number of channels	2 (RS-232 A and RS-232 B)
Type	RS-232, full duplex
Transmission rate [Bit/s]	300...19K2 Bit/sec
Data bits	7/8
Input signal level	Logic 1 (high) -3...-15 V Logic 0 (low) +3...+15 V
Output signal level	Logic 1 (high) -5...-15 V Logic 0 (low) +5...+15 V
Number of signals	Input: RxD, CTS Output: TxD, RTS

Description	Data
Potential isolation	None
Cable type	Twisted pair, screened (e.g. LifYCY 3x2x0.20), 1 pair of wires for ground (GND).
Cable gauge	1.5 mm ²
Cable length	max. 15 m

Block diagram RS-232

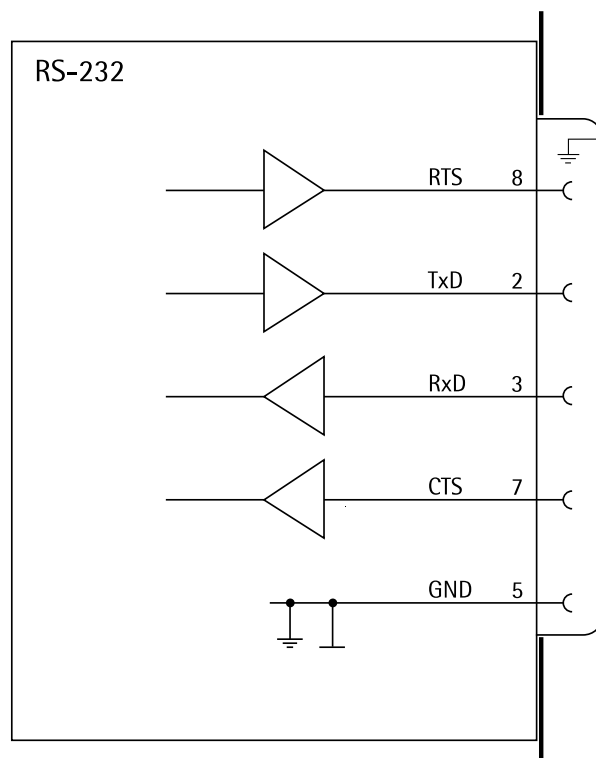

Note:

For more information, see Chapter [4.5.4](#).

4.7.3 1x RS-232 interface and 1x RS-485 interface

This interface card has the type designation PR 5510/04.

The plug-in card has one RS-232 channel and one RS-422/485 channel which can be used simultaneously and more or less independently (depending on the transfer rate) from each other.

Up to two PR 5510/04 cards can be plugged into "Slot 1" and "Slot 2."

These interfaces are configurable, and can be used, for example, for data transmission to a remote display or printer.

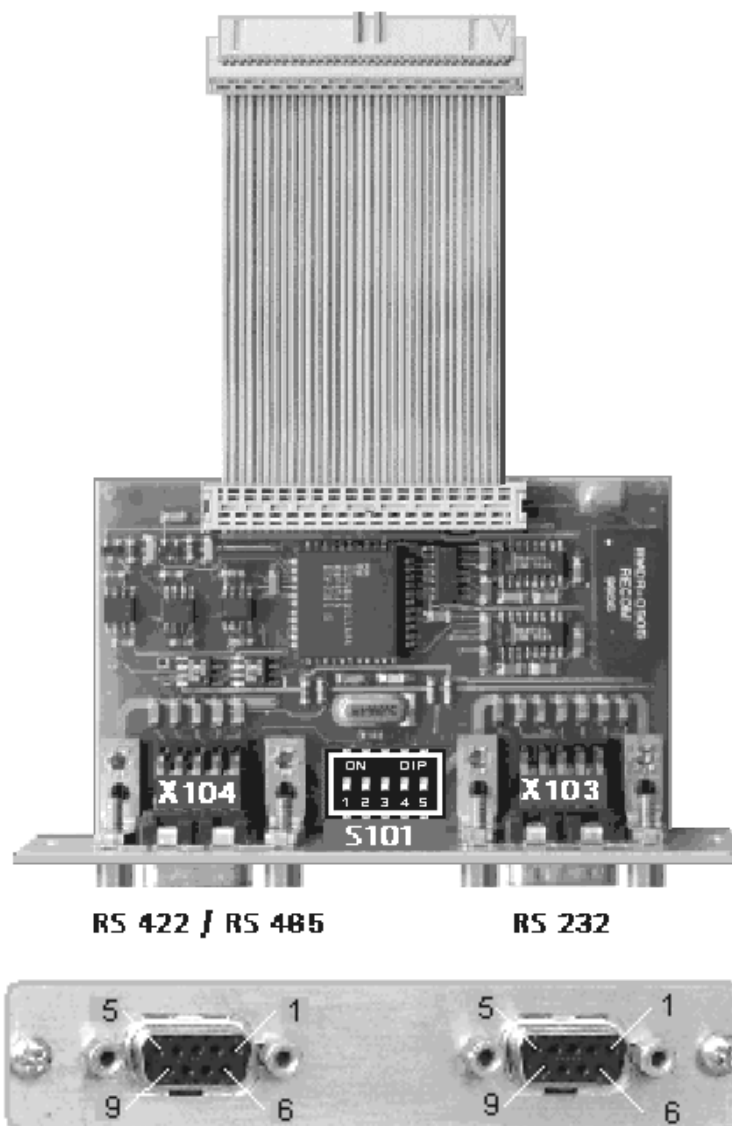

RS 422 / RS 485

RS 232

Specifications

Description	Data
Connection	2x D-Sub female connector, 9-pin
Number of channels	2 (RS-232 and RS-422/485)
Transmission rate [Bit/s]	300, 600, 1200, 2400, 4800, <9600>, 19200 bit/sec
Cable type	Twisted pair, screened (e.g. LifYCY 3x2x0.20), 1 pair of wires for ground (GND).
Cable gauge	1.5 mm ²

<...> = preset values (factory settings)

4.7.3.1 RS-232 channel

The RS-232 interface depends on the "S101" switch settings.

It can only be used as a point-to-point connection.

PR 5510/04 is set up in the RS-232 channel the same as the fixed interface, but it has additional signals: DCD, RI, DTR.

Specifications

Description	Data
Type	RS-232, full duplex
Data bits	7/8
Input signal level	Logic 1 (high) -3...-15 V Logic 0 (low) +3...+15 V
Output signal level	Logic 1 (high) -5...-15 V Logic 0 (low) +5...+15 V
Number of signals (24 V)	Input: RxD, CTS, DCD, RI Output: TxD, RTS, DTR
Potential isolation	None
Cable length	max. 15 m

Block diagram RS-232

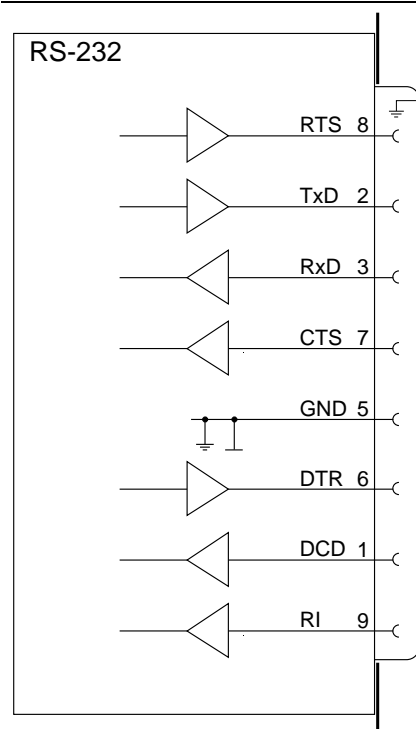

Note:

For more information, see Chapter [4.5.4](#).

4.7.3.2 RS-485 channel

The RS-485/422 interface must be configured using switch "S101" after being installed on the card.

The RS-485 interface can also be used as a point-to-point connection.

Using RS-485 is compulsory with a multi-point connection (Tristate status).

Specifications

Description	Data
Type	RS-422/485, full duplex (4-wire) RS-485, half duplex (2-wire)
Bits/stopbit	<8/1> or 7/1
Parity	Even, <odd>, none
Signals	TxA, RxA, TxB, RxB
Potential isolation	Yes
Cable length	max. 1000 m

<...> = preset values (factory settings)

Switch S101

RS-422/485 block diagram

Factory setting:

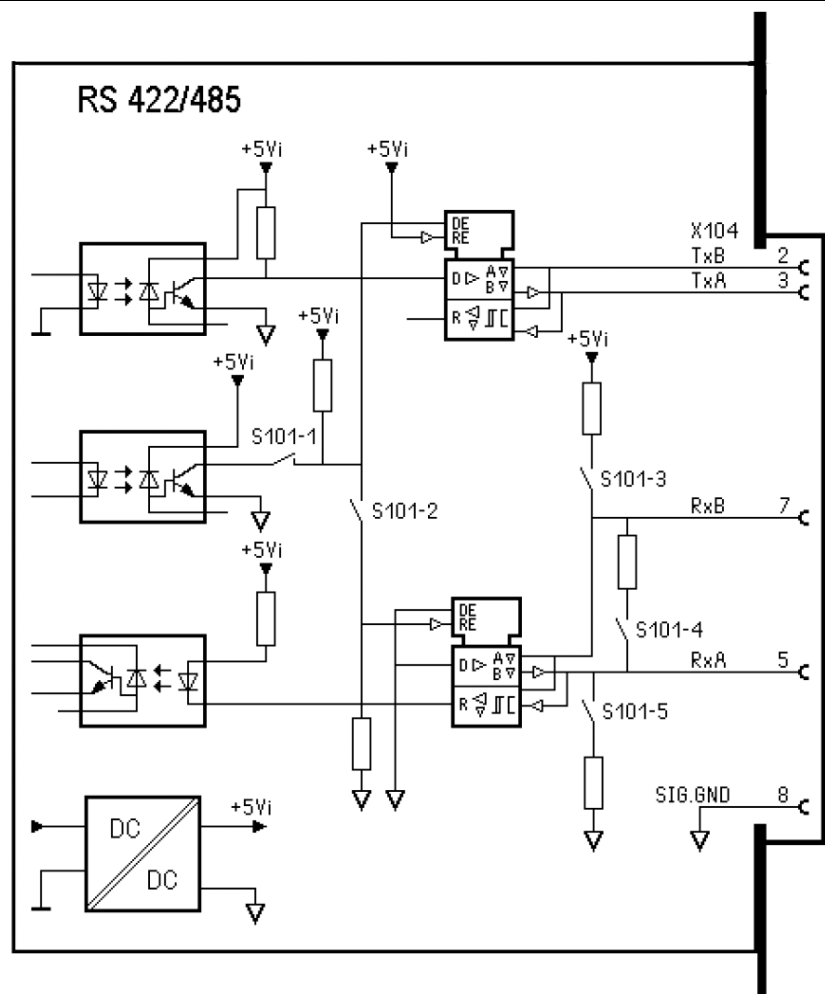

S	Function	Settings for RS-422/485	
1	Tx enable (unblock)	OFF: RS-422	ON: RS-485
2	Rx enable (unblock)	OFF: 4-wire	ON: 2-wire
3	Rx pull-up resistor	OFF: not connected	ON: (RxB 1K54 Ω +V)
4	Rx bus termination	OFF: not connected	ON: (RxA 205E Ω RxB)
5	Rx pull-down resistor	OFF: not connected	ON: (RxA 1K54 Ω -V)

Switch setting mode

S101	2-wire system		4-wire system	
	Point to point	Bus	Point to point	Bus
Master	RS-485 1, 2, 3, 4, 5 = ON	RS-485 1, 2, 3, 4, 5 = ON	RS-422 4 = ON 1, 2, 3, 5 = OFF	RS-422 3, 4, 5 = ON 1, 2 = OFF
Individual slave	RS-485 1, 2 = ON 3, 4, 5 = OFF	...	RS-422 4 = ON 1, 2, 3, 5 = OFF	...
Other slaves	...	RS-485 1, 2 = ON 3, 4, 5 = OFF	...	RS-485 1 = ON (default) 2, 3, 4, 5 = OFF
Last slave	...	RS-485 1, 2, 3, 4, 5 = ON	...	RS-485 1, 3, 4, 5 = ON 2 = OFF

4.7.3.2.1 RS-422 point-to-point connection (4-wire)

4-wire transfer mode:

Full duplex (simultaneous sending and receiving possible) RS-422 can only be used for point-to-point connection.

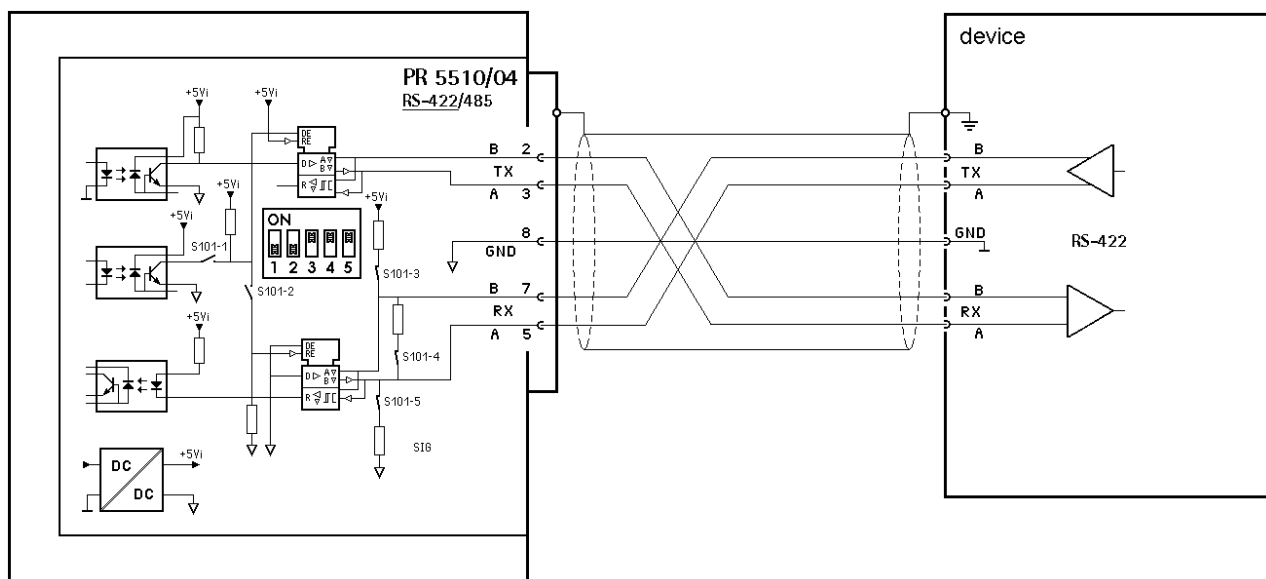



Switch settings	Configuration
ON: S3, S4, S5 OFF: S1, S2	 - [Serial ports parameter]- [...] - [Slot 1/2 RS485]

Note:
For more information on the switch settings, see Chapter [4.7.3.2](#).

4.7.3.2.2 RS-485 point-to-point connection (2-wire)

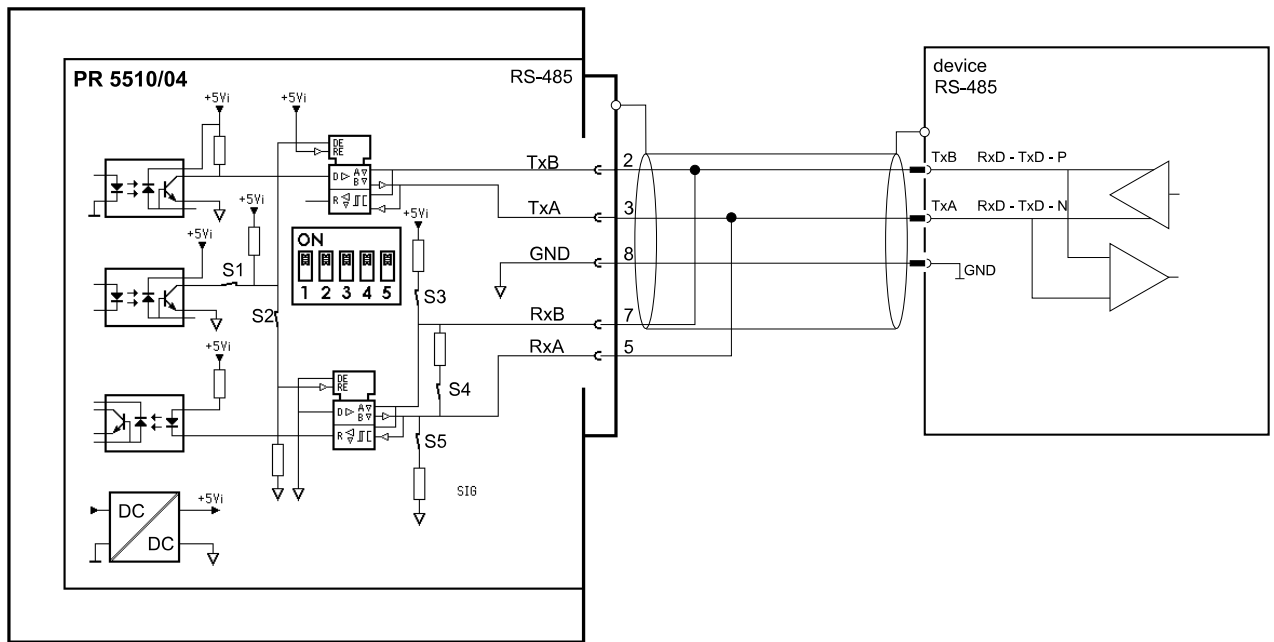
2-wire transfer mode:
Half duplex (simultaneous sending and receiving not possible)



Switch settings	Configuration
ON: S1, S2, S3, S4, S5 OFF: ...	 - [Serial ports parameter]- [...] - [Slot 1/2 RS485]

Note:
For more information on the switch settings, see Chapter [4.7.3.2](#).

4.7.3.2.3 Connecting an IS platform

One IS platform scale with xBPI or SBI protocol can be connected via the RS-485 interface (2-wire).

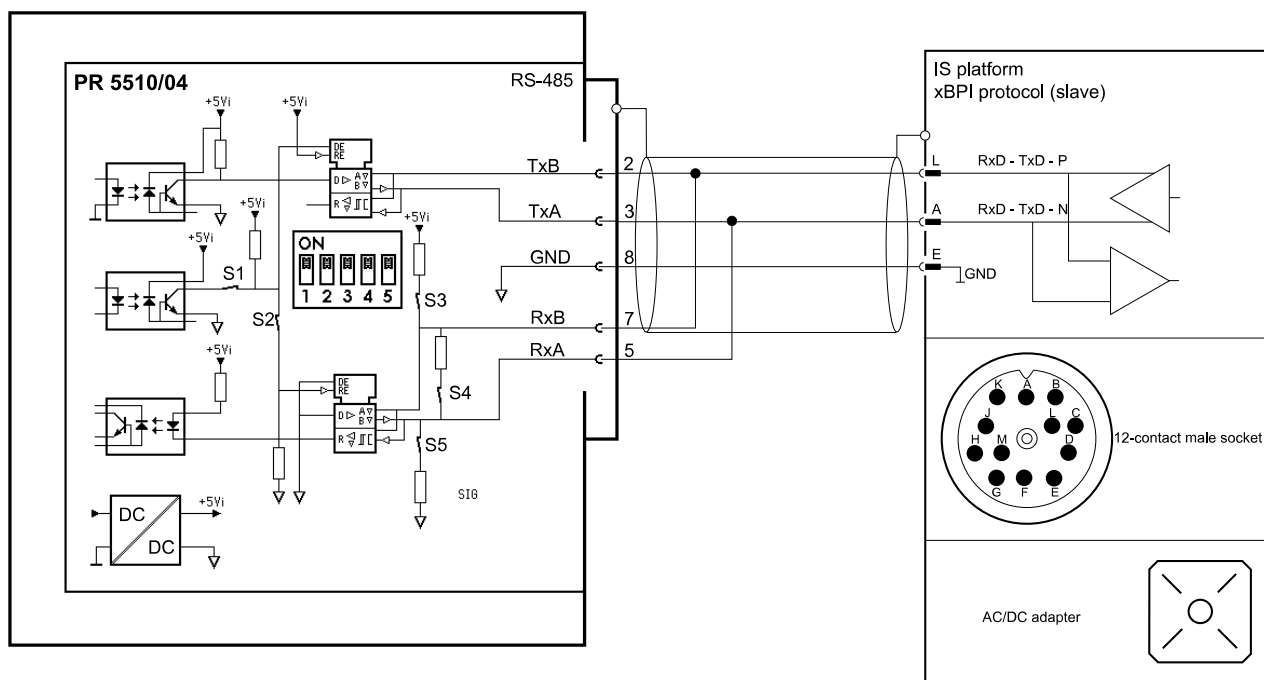

Switch settings PR 5410

ON: S1, S2, S3, S4, S5
 OFF: ...

Configuration PR 5410

 - [Serial ports parameters]- [xBPI port]- [Slot 1/2 RS-485]

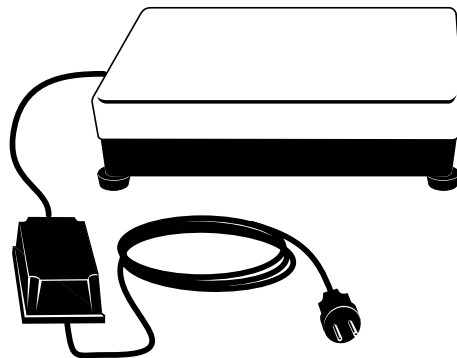

Note:

For further information, see the platform scale operating instructions.

4.7.3.2.4 Connecting digital load cells from type Pendeo®

The device can be ported to Pendeo® type digital load cells via the xBPI port and the RS-485 interface (2-wire).

Connections

Color code	Color	Terminal designation	Description
rd	red	+	+ Supply voltage
bu	blue	-	- Supply voltage
gr	green	B	B Signal
gy	gray	A	A Signal

The following example shows the connection to the PR 6024/68S junction box using 8 digital load cells, type Pendeo®.

Connection example

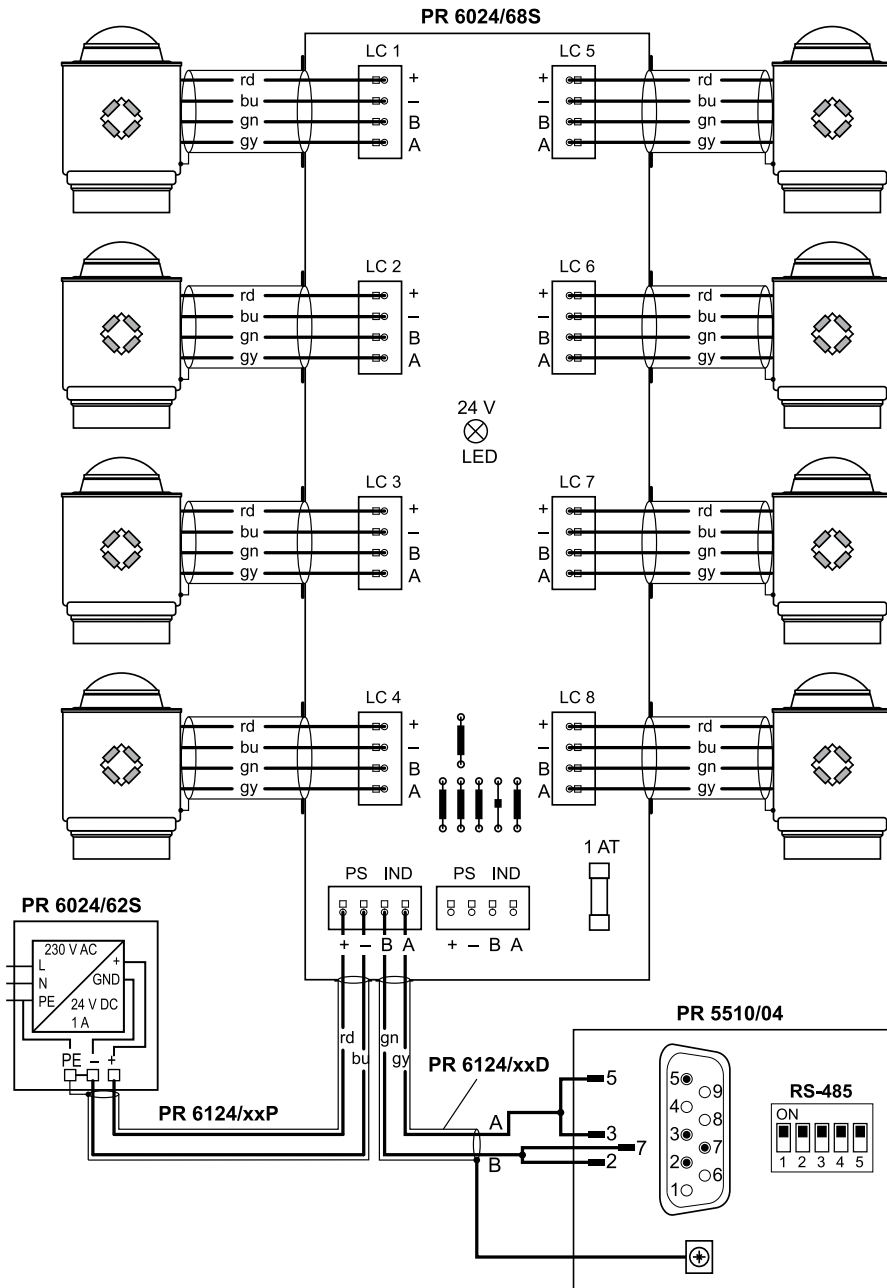

PR 5410 switch settings

ON: S1, S2, S3, S4, S5
 OFF: ...

PR 5410 configuration

 - [Serial ports parameter] - [xBPI-Port] - [Slot 1/2 RS485]

Note:

For further information, see the installation manuals relating to the load cells and junction boxes.

4.7.4 CANopen interface

The CANopen interface card has the type designation PR 5510/05.

Only one PR 5510/05 card can be plugged into "Slot 1" or "Slot 2".

The CANopen interface card is supported by software version 4.60.

This is used to connect the Connexx modules via a CAN bus.

The interface can supply a maximum of 4 Connexx modules via the D-Sub connection. For more than 4 Connexx modules, an external power supply is required that can also be connected to this interface card.

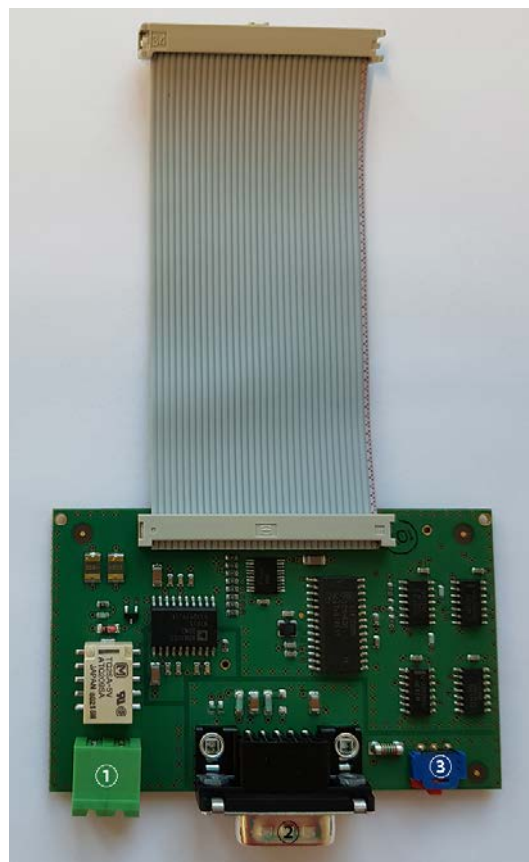

Technical data

Description	Data
Connexx module connection	1x D-Sub 9-pin plug connector, male ②
Transmission rate [bit/s]	250 kBit/sec
Potential isolation	yes
Bus termination	Terminating resistor ③ of 120 Ω can be connected via a switch Switch in position "a" = not turned on Switch in position "b" = turned on
Supply using PR 5410	± 9 V (max. 160 mA)
Supply using an external power supply	$U_{DC} = 24$ V @ ≥ 500 mA
Cable length	recommended: <40 m
Certificates	Supports the CAN 2.0B Specification
Power supply connection	1x 2-pin plug connector, male ①
Number of modules	max. 12

Assignment of the D-Sub plug (male), 9-pin

Pin assignment	Signal	Color	Description
Cable sheath			Special CAN bus cable (certified)
2 -----	CAN_L	gray (green/ yellow)	CAN_L bus signal
3 -----	GND/C	brown	Ground of the galvanically isolated Can bus interface supply from the Connexx modules
6 -----	-9 V/GND	blue	Negative power supply
7 -----	CAN_H	black	CAN_H bus signal
9 -----	+9 V/Uext	white	Positive power supply

4.7.5 Connexx module

4.7.5.1 Technical data

The Connexx module is the electronic part of a so-called "digital load cell".

The analog weight data (mV/V) is digitalized using a 24-bit $\Sigma\Delta$ converter.

A micro-controller converts the data into a CAN bus signal and transmits the processed signals via the CANopen interface PR 5410/05 to the PR 5410 for further processing.



- ① M12 plug connector, female
- ② M12 plug connector, male
- ③ Status LED
- ④ Load cell cable

Technical data

Description	Data
Connection PR 5410/05 or previous module (power supply connection) ②	M12 plug connector, male
Connection to the next Module (CAN bus) ①	M12 plug connector, female
Supply voltage	nominal $U_{DC} = 24\text{ V}$ (max. 18–36 V)
Supply voltage load cell	$U_{DC} = \text{approx. } 5\text{ V}$
Connecting cables	
Protection classes	in compliance with EN 60529 IP68: Dust-proof and leak-tight against water ingress, with harmful effects when immersed, (1.5 m water depth, 100 h).

Status LED

LED status	Color	Function
flashing	red	- No communication - Data defect
duration	red	no weight values provided

LED status	Color	Function
duration	green	- Weight values provided - Load cell recognized
flashes alternately	green/red	Electronics are being configured.

4.7.5.2 Connection of Connexx modules

Connexx modules can be connected to the device via the options card PR 5510/05 (see Chapter [4.7.4](#)).

- ≤4 Connexx modules without external voltage supply
- >4 Connexx modules with external voltage supply (see Chapter [4.7.5.4](#))

When connecting the external voltage supply, the device automatically switches from an internal to an external power supply.

- A maximum of 12 Connexx modules are possible.
- The connecting parts are listed in Chapter [4.7.5.3](#).

Cable lengths

Connecting part	Recommended length
Between PR 5410 and Connexx module	max. 40 m
Between PR 5410 and external voltage supply	max. 3 m
Between the individual Connexx modules	max. 10 m

Connections

Color abbreviations	Color	Description
wh	white	+ Supply voltage
bu	blue	- Supply voltage
bn	brown	GNDC
gy	gray	CAN_L bus signal (material PUR)
gr/ye	green/yellow	CAN_L bus signal (material PVC)
bk	black	CAN_H bus signal

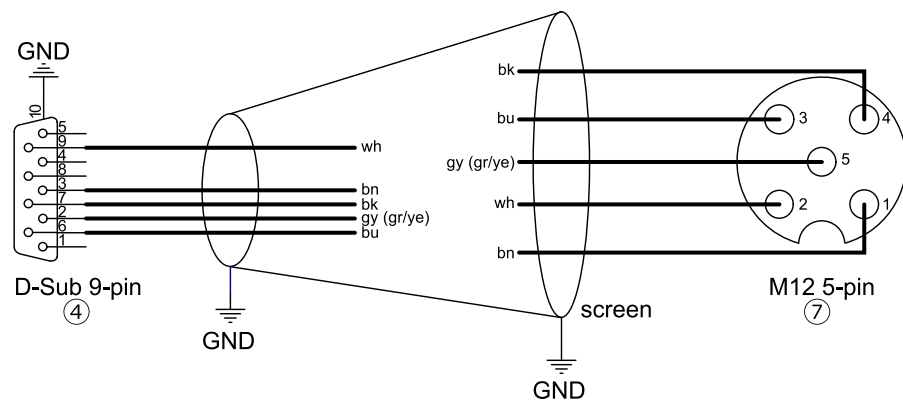
Connection diagram D-Sub 9-pin → M12 5-pin**Note:**

There are two types of cable that can be used to connect the PR 5510/05 option (CANopen interface in the PR 5410) to the first Connexx module.

- PR 6152/10, ../25, and ../40 are pre-assembled cables with an M12 5-pin plug connector and a D-Sub 9-pin plug connector, see also Chapter [4.7.5.3](#).
- PR 6152/11, ../26, and ../41 are cables with an M12 5-pin plug connector, to which a D-Sub 9-pin plug connector with screw connectors can be connected. See also Chapter [4.7.5.3](#).

This variant is used, for example, if the cable is to be fed through a cable gland.

NOTICE**Incorrect assignment of the D-Sub plug connector, female.**

Destruction of the Connexx module.

- The connection diagram shown must be adhered to.

Connection example, shown as a diagram

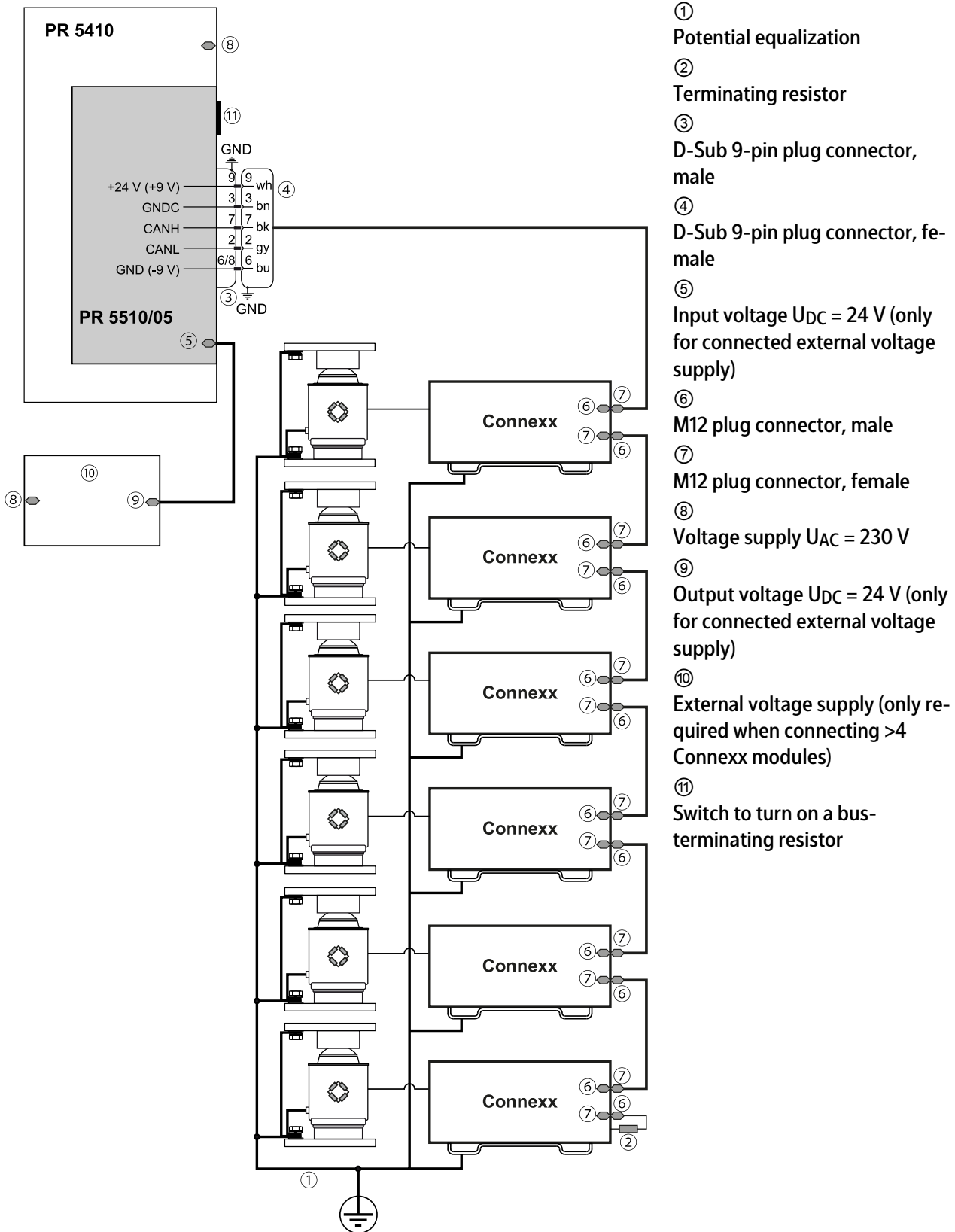

4.7.5.3 Connecting parts for the Connexx module

To connect the Connexx module, the following connecting parts are required:

No.	Description	Order no.
1	PR 5510/05 CANopen interface for PR 5410	9405 355 10051
2	PR 6154/03 Connexx connecting kit for three load cells (comprising: 2× PR 6155/05, 1× PR 6152/25, 1× PR 6153/99)	9405 361 54031
3	PR 6154/04 Connexx connecting kit for four load cells (comprising: 3× PR 6155/05, 1× PR 6152/25, 1× PR 6153/99)	9405 361 54041
4	PR 6154/06 Connexx connecting kit for six load cells (comprising: 5× PR 6155/10, 1× PR 6152/25, 1× PR 6153/99)	9405 361 54061
5	PR 6154/08 Connexx connecting kit for eight load cells (comprising: 7× PR 6155/10, 1× PR 6152/25, 1× PR 6153/99)	9405 361 54081
6	PR 6155/05 Connecting cable between individual Connexx modules (M12 plug connector, male → M12 plug connector, female); 5 m	9405 361 55051
7	PR 6155/10 Connecting cable between individual Connexx modules (M12 plug connector, male → M12 plug connector, female); 10 m	9405 361 55101
8	PR 6152/10 Connecting cable between Connexx module and CANopen interface (M12 plug connector, female → D-Sub 9-pin plug connector, female); 10 m	9405 361 52101
9	PR 6152/11 Connecting cable between Connexx module and CANopen interface (M12 female → open cable ends incl. D-Sub 9-pin plug connector, female with screw connectors); 10 m	9405 361 52111
10	PR 6152/25 Connecting cable between Connexx module and CANopen interface (M12 plug connector, female → D-Sub 9-pin plug connector, female); 25 m	9405 361 52251
11	PR 6152/26 Connecting cable between Connexx module and CANopen interface (M12 plug connector, female → open cable ends incl. D-Sub 9-pin plug connector, female with screw connectors); 25 m	9405 361 52261
12	PR 6152/40 Connecting cable between Connexx module and CANopen interface (M12 plug connector, female → D-Sub 9-pin plug connector, female); 40 m	9405 361 52401
13	PR 6152/41 Connecting cable between Connexx module and CANopen interface (M12 plug connector, female → open cable ends incl. D-Sub 9-pin plug connector, female with screw connectors); 40 m	9405 361 52411
14	PR 6153/98 Split cable gland for connecting cable PR 6152/.. with D-Sub plug connector, female	9405 361 53981
15	PR 6153/ 99 Terminating resistor for Connexx module (M12 plug connector, male)	9405 361 53991

4.7.5.4 External voltage supply specifications

If more than four Connexx modules are to be connected, an external power supply must be used for the voltage supply.

Ambient conditions

Ambient temperature for operation	-25...+70 °C
Interference resistance	EN 61000-6-2:2005

Entry data

Nominal input voltage range	$U_{AC} = 100...240\text{ V}$
Input voltage range AC	$U_{AC} = 85...264\text{ V}$
Frequency range AC	45...65 Hz

Output data

Nominal output voltage	$U_{DC} = 24\text{ V} \pm 1\%$
Output current	1.0 A

Connection data output

Connection type	1× terminal, 2-pin Phoenix Contact MVSTBW 2.5/2-ST-5.08
-----------------	--

4.7.6 Analog inputs and outputs

The interface card has the type designation PR 5510/07.

The plug-in card has one active analog output and 4 analog inputs. The analog inputs are not supported by the standard device.

Only one PR 5510/07 card can be plugged into "Slot 1" or "Slot 2".

The analog inputs must be configured via the switch "S201" or "S202" after the installation on the card.

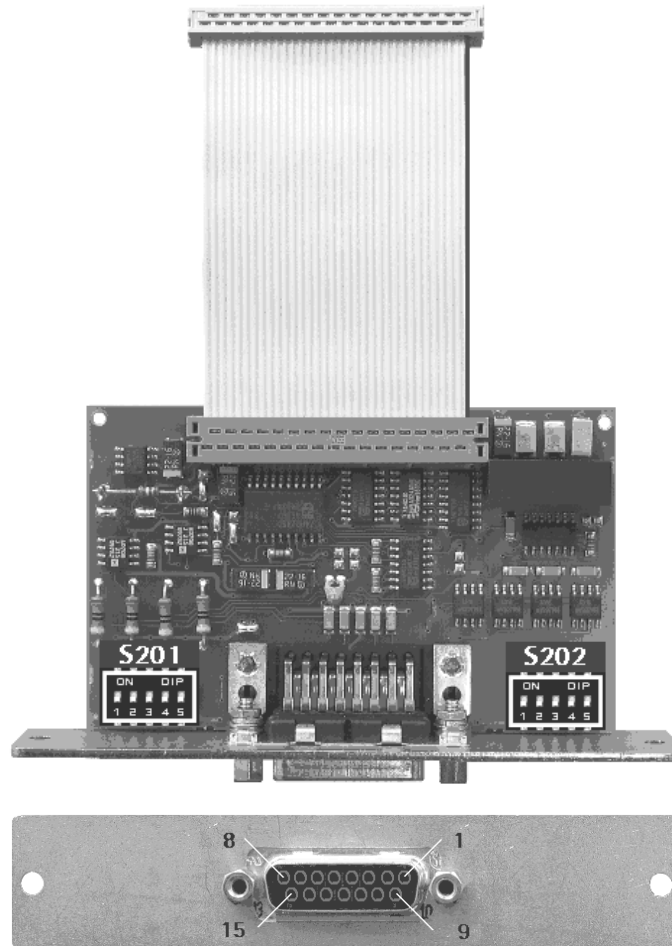

Analog inputs

PIN	2	9	3	10	4	11	5	12
4 channels	+CH1	GND	+CH2	GND	+CH3	GND	+CH4	GND

Analog output

PIN	13	14
1 channel	+0/4...20 mA	Sig GND

Note:

For more information, see Chapter [4.7.1](#).

Technical data

Description	Data
Connection	D-Sub female connector, 15-pin
Output: Number	1 active current output: 0/4...20 mA (max. 24 mA), 10 V output voltage via external 500 Ω resistor
Output: Function	according to gross weight/net weight/display, configurable
Output: Range	0/4... to 20 mA, configurable
Output: Resolution	Internal 16 bits = 65536 counts, resolution of 20,000 @ 20 mA
Output: Linearity error	@ 0 to ...20 mA: <0.04% @ 4 to ...20 mA: 0.02%
Output: Temperature error	<100 ppm/K
Output: Zero point error	0.05%
Output: Max. error	<0.1%
Output: Load	Max. 0... to 500 Ω
Output: Protected against short- circuit	yes
Output: Potential isolation	yes
Inputs:	4x channel current or voltage input 0...20 mA, input impedance 250 Ω 0...10 V, input impedance 100 k Ω 0...5 V, input impedance >10 M Ω
Input: Resolution	3,000 internal counter steps e. G. 0...20 mA/0...10 V
Input: Accuracy	0.2 %
Input: Linearity error	<0.03%
Input: Temperature error	<50 ppm/K
Input: Reserve	$\pm 15\%$, i. e. $-1.5\text{ V} \dots +11.5\text{ V}$
Input: Potential isolation	no
Cable type	Screened twisted pair (e. g., LifYCY 2x2x0.20)
Cable length	<150 m screened
Accessories	D-sub plug, 15-pin

Switch for analog inputs

PR 5510/07 Block diagram

Factory settings:

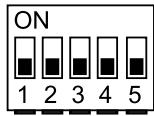

S201

Factory settings:

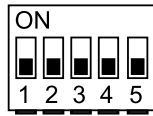

S202

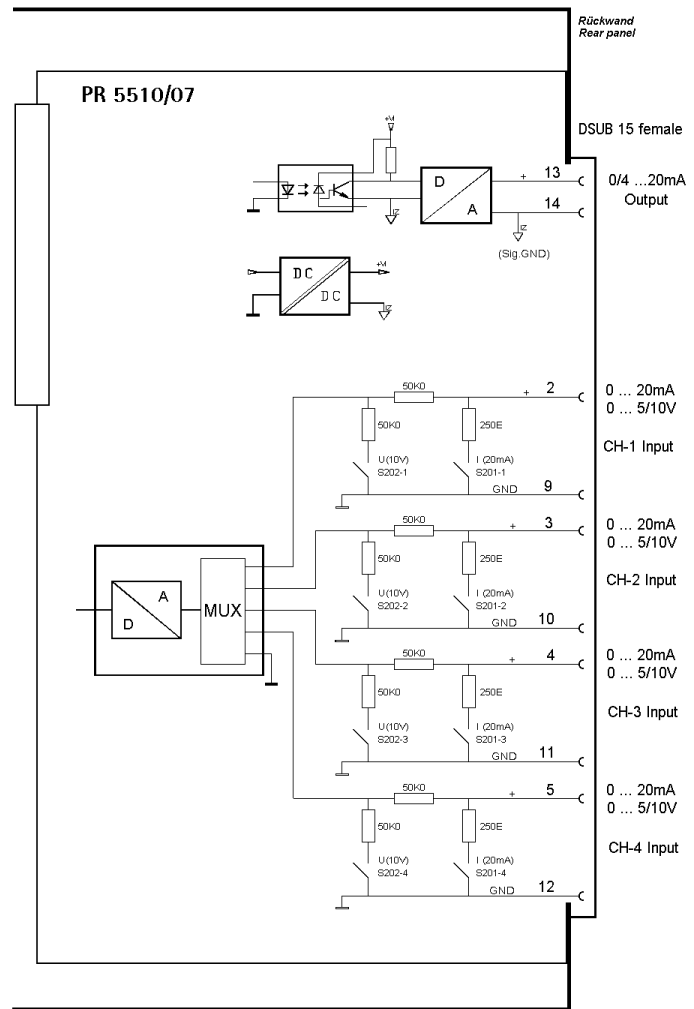

S	Channel	Current 0...+20 mA DC	Voltage 0...+10 V DC	Voltage 0...+5 V DC
S201-1	CH1	ON	OFF	OFF
S201-2	CH2	ON	OFF	OFF
S201-3	CH3	ON	OFF	OFF
S201-4	CH4	ON	OFF	OFF
S201-5
S202-1	CH1	OFF	ON	OFF
S202-2	CH2	OFF	ON	OFF
S202-3	CH3	OFF	ON	OFF
S202-4	CH4	OFF	ON	OFF
S202-5
Input impedance		250 Ω	100 kΩ	>10 MΩ

4.7.7 BCD output (open emitter)

This interface card has the type designation PR 5510/08.

A PR 5510/08 card can be plugged into "Slot 2" only.

The plug-in card is used for BCD-coded output of a 5-decade weight value.

Cyclical output of the weight value with 4-bit (plus or minus sign, stability, error). The value is intrinsically consistent and can be output continuously or the digital input "DATA_IN" control can be used to freeze (hold) the value.

Before installing the card, set switches "S101" and "S102".

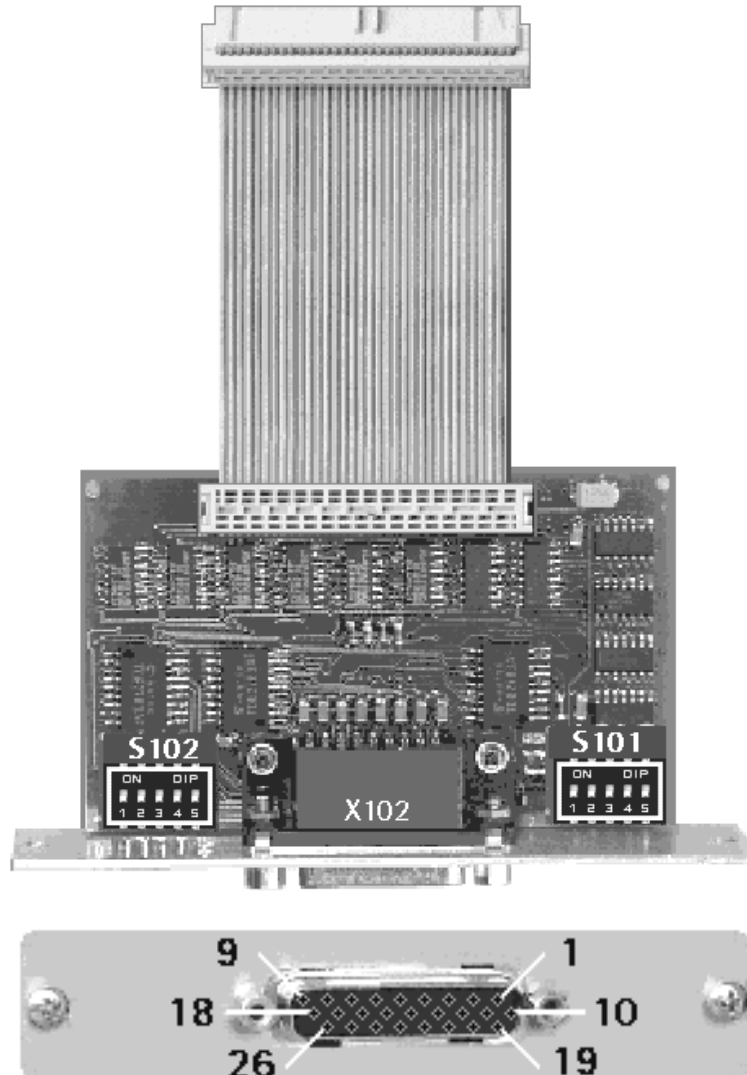

Specifications

Description	Data
Connection	D-SUB female connector, 26-pin
Output: Qty	5 digit BCD + preceding sign
Input: Qty	1 bit "DATA_IN"
Output level	Shared collector at +Uext., open emitter
External supply	U _{DC} = +5 V...+24 V

Description	Data
Voltage drop	Approx. 1.7 V
Output current	Max. 50 mA
Enable input	5 V/24 V configurable via switch S101 @ 5 V active-high >3.1 V; active-low <1.5 V @ 24 V active-high >16 V; active-low <10 V Protection against incorrect polarity
Potential isolation	No
Cable type	Screened twisted pair (e.g. LifYCY 2x2x0.20)
Cable length	max. 50 m screened
Accessories	D-SUB male connector, 26-pin Incl. shielded housings

Switch for input

PR 5510/08 block diagram

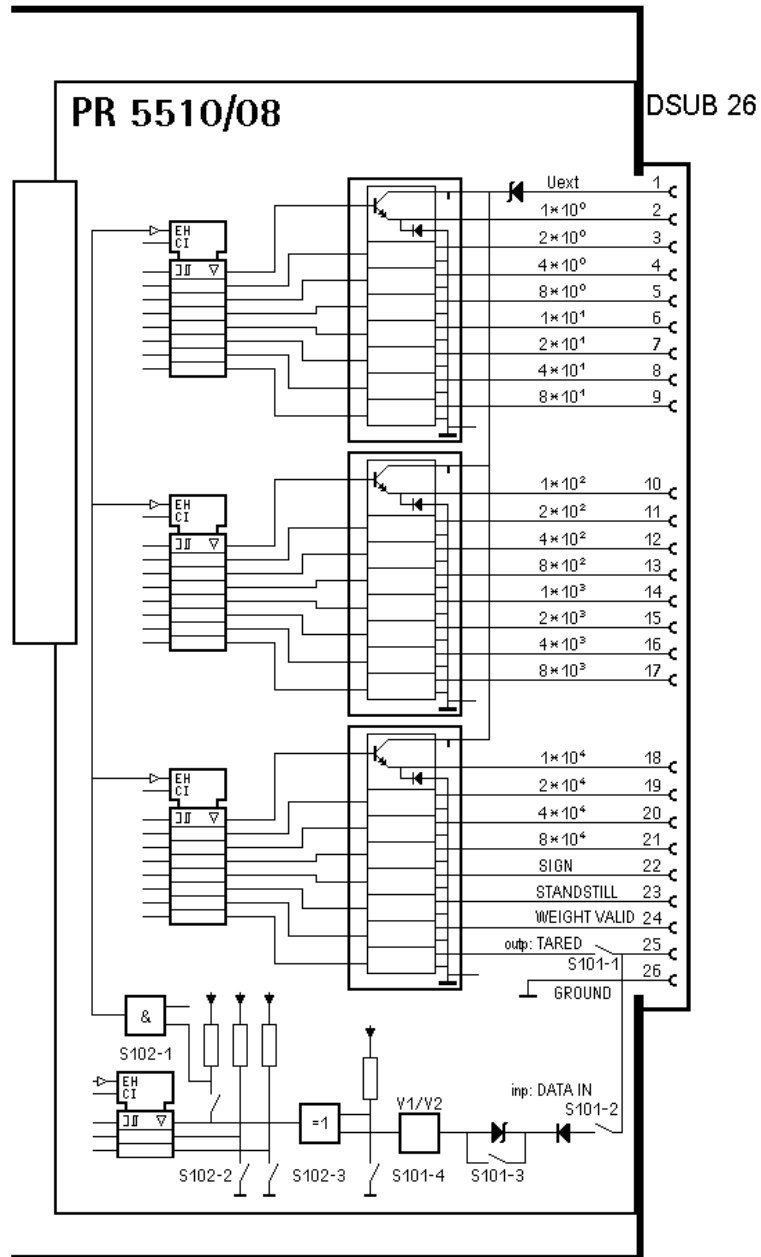

An external power supply is required: PIN 1 (Uext), reference potential PIN 26 (GND)

4.7.7.1 Outputs

The outputs for PR 5510/08 (PIN 2...24) work with a shared power supply at the collector as a reference potential and open emitter outputs.

A non-active output is highly resistant.

A voltage of approx. 1.7 V, which is less than the supply voltage, is applied to an active output.

The load to be connected is between the outputs (PIN 2...24, 25) and GND (PIN 26).

Output circuitry

Voltage output

PR 5510/08

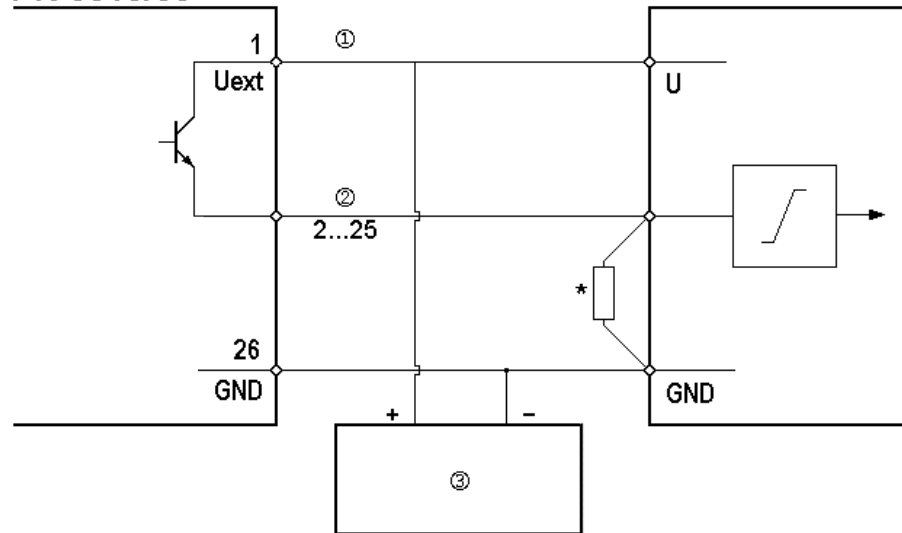

① common reference potential

② outputs

③ supply unit $U_{DC} = 24\text{ V } 0.5\text{ A}$

* The load resistance must be $2.2\text{ k}\Omega/1\text{ k}\Omega$ with $24\text{ V}/5\text{ V}$.

Current output

PR 5510/08

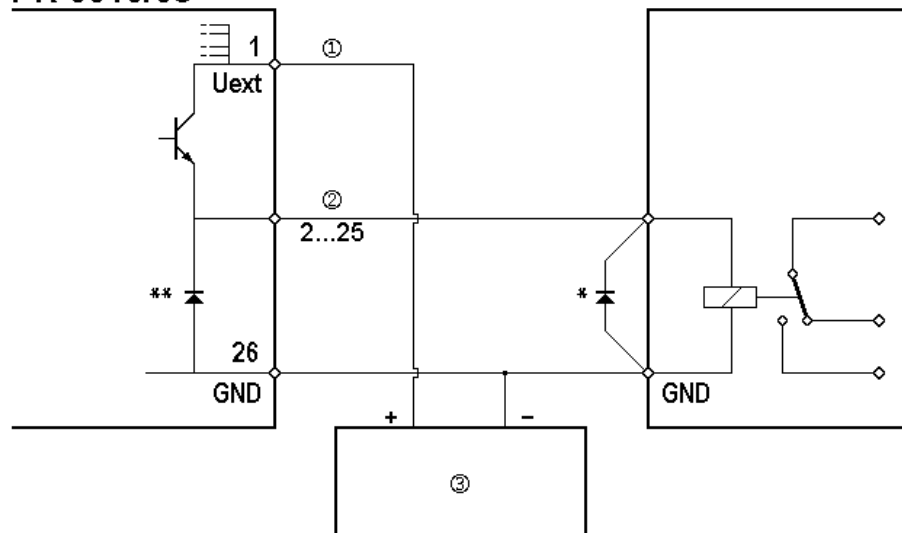

① common reference potential

② outputs

③ supply unit $U_{DC} = 24\text{ V } 0.5\text{ A}$

Recommendation:

* additional external free-wheel diode

** additional internal free-wheel diode, only for very small inductive loads

4.7.7.2 Input

The Enable input for PR 5510/08 (PIN 25) can control the 23 outputs as DATA_IN.

As an output, data is "follow/hold/tristate" and its signal can be configured 5 V (TTL)/24 V and active-high/active-low.

It is applied to pin 25 (DATA_IN) of the 26-pin connector and is effective only with switches S101-1 = OFF and S101-2 = ON.

The switch settings can be found in the table in Chapter [4.7.9](#).

4.7.8 BCD output (open collector)

This interface card has the type designation PR 5510/09.

A PR 5510/09 card can be plugged into "Slot 2" only.

The plug-in card is used for BCD-coded output of a 5-decade weight value.

Cyclical output of the weight value with 4-bit (plus or minus sign, stability, error). The value is intrinsically consistent and can be output continuously or the digital input "DATA_IN" control can be used to freeze (hold) the value.

Before installing the card, set switches "S101" and "S102".

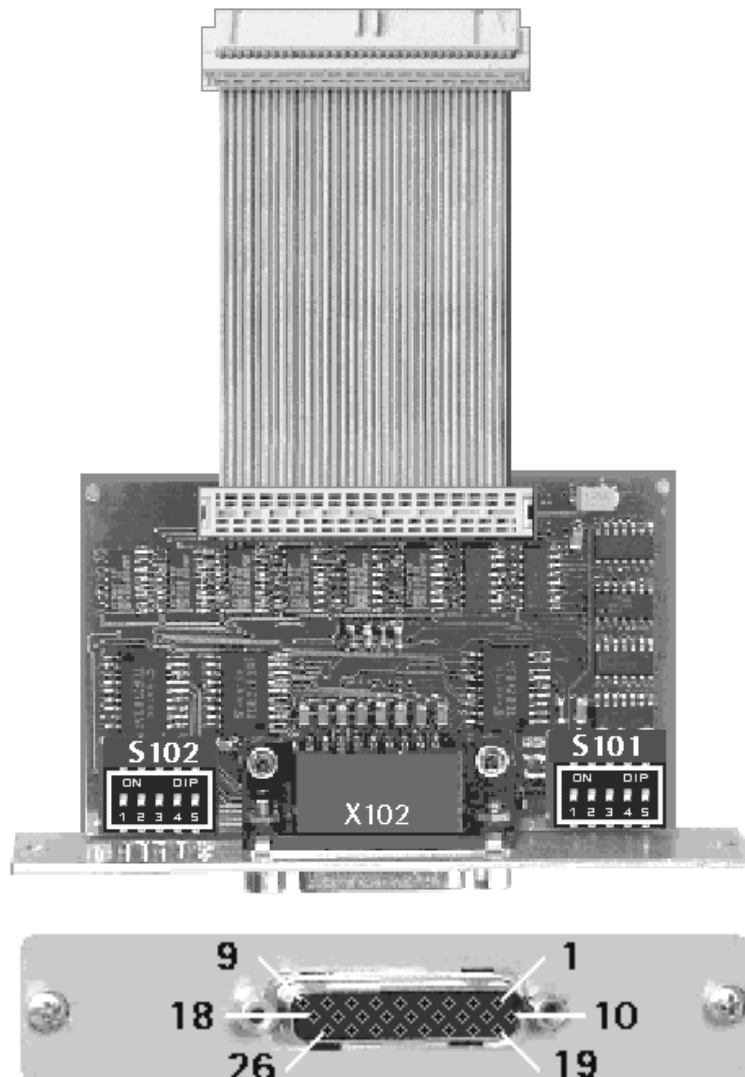

Specifications

Description	Data
Connection	D-SUB female connector, 26-pin
Output: Qty	5 digit BCD + preceding sign
Input: Qty	1 bit "DATA_IN"
Output level	Shared emitter to ground, open collector
External supply	U _{DC} = +5 V...+24 V
Voltage drop	Approx. 0.9 V
Output current	Max. 50 mA
Enable input	5 V/24 V configurable via switch S101 @ 5 V active-high >3.1 V; active-low <1.5 V @ 24 V active-high >16 V; active-low <10 V Protection against incorrect polarity
Potential isolation	No
Cable type	Screened twisted pair (e.g. LifYCY 2x2x0.20)
Cable length	max. 50 m screened
Accessories	D-SUB male connector, 26-pin Incl. shielded housings

Switch for input

PR 5510/09 block diagram

Factory setting:

Factory setting:

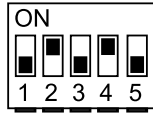

S102

S101

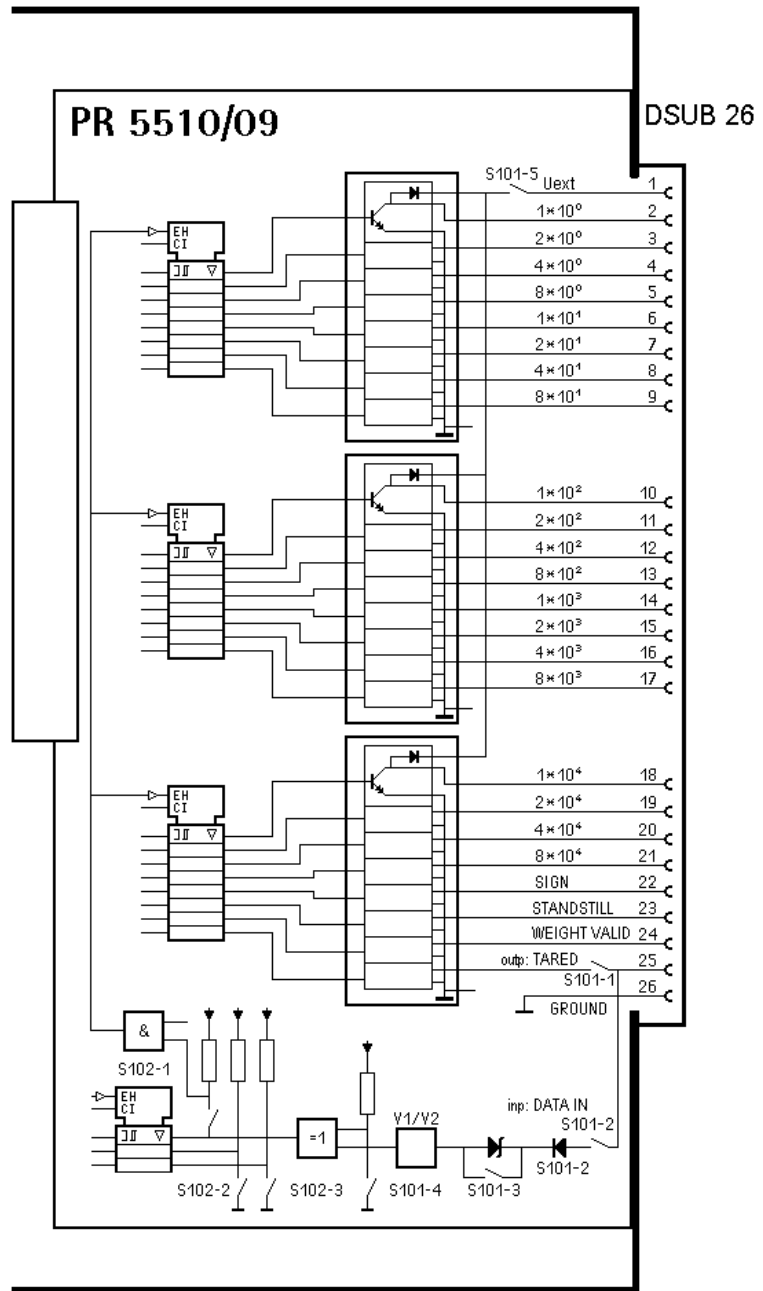

An external power supply is required: PIN 1 (Uext), reference potential PIN 26 (GND)

4.7.8.1 Outputs

The outputs for PR 5510/09 (PIN 2...24) work as a reference potential and open collectors with a shared ground.

A non-active output is highly resistant.

A voltage of 0.9 V is applied to an active output via GND.

The load to be connected is between the outputs (PIN 2...24, 25) and Uext (PIN 1).

Output circuitry

Voltage output

PR 5510/09

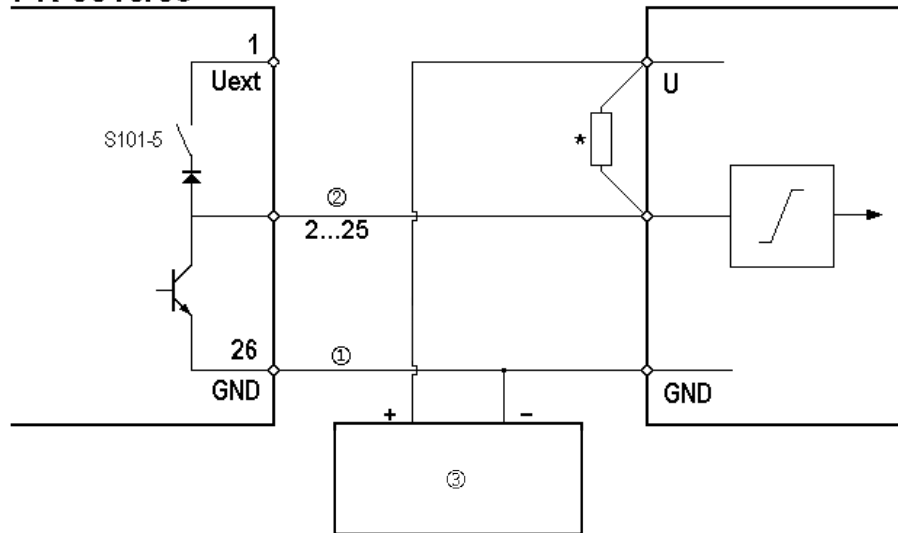

① common reference potential

② outputs

③ supply unit $U_{DC} = 24\text{ V } 0.5\text{ A}$

* The load resistance must be $2.2\text{ k}\Omega/1\text{ k}\Omega$ with $24\text{ V}/5\text{ V}$.

The internal free-wheel diode is not activated: S101-5 = OFF

Current output

PR 5510/09

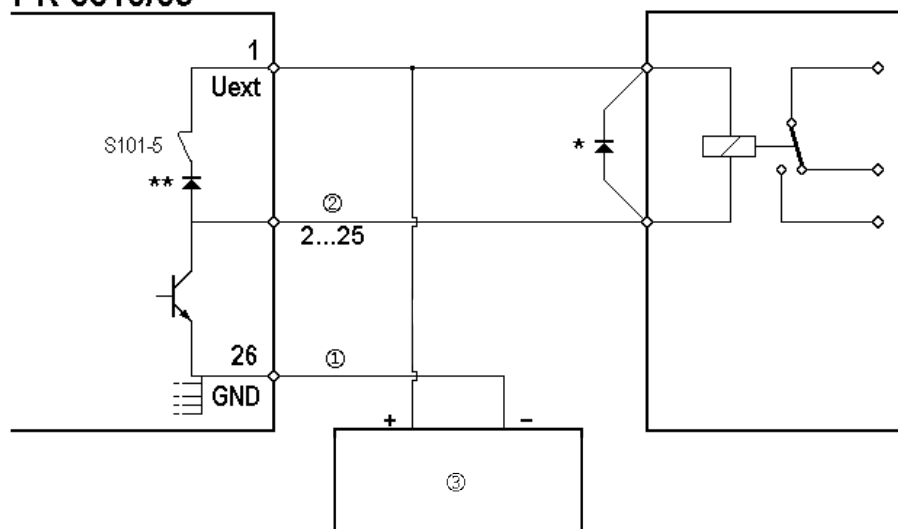

① common reference potential

② outputs

③ supply unit $U_{DC} = 24\text{ V } 0.5\text{ A}$

Recommendation:

* additional external free-wheel diode

** additional internal free-wheel diode, only for very small inductive loads

4.7.8.2 Input

The Enable input for PR 5510/09 (PIN 25) can control the 23 outputs as DATA_IN.

As an output, data is "follow/hold/tristate" and its signal can be configured 5 V (TTL)/24 V and active-high/active-low.

It is applied to pin 25 (DATA_IN) of the 26-pin connector and is effective only with switches S101-1 = OFF and S101-2 = ON.

The switch settings can be found in the table in Chapter [4.7.9](#).

4.7.9 Switch settings

Switch S101

Input	External supply		S101 for	-1	-2	-3	-4	-5
DATA_IN	5 V	active-high	PIN 25	OFF	ON	ON	ON	ON or OFF
DATA_IN	5 V	active-low	PIN 25	OFF	ON	ON	OFF	ON or OFF
DATA_IN	24 V	active-high	PIN 25	OFF	ON	OFF	ON	ON or OFF
DATA_IN	24 V	active-low	PIN 25	OFF	ON	OFF	OFF	ON or OFF
activate internal free-wheel diode								ON
do not activate internal free-wheel diode								OFF

Switch S102

Input (PIN 25)	Function for the output data		S102 for	-1	-2	-3	-4	-5
DATA_IN	follow	hold	PIN 2...24	OFF	OFF	ON	ON or OFF	ON or OFF
DATA_IN	tristate	follow	PIN 2...24	ON	ON	OFF	ON or OFF	ON or OFF
DATA_IN	tristate	hold	PIN 2...24	ON	ON	ON	ON or OFF	ON or OFF

Input level

Input (PIN 25)	External supply		Voltage	Current
DATA_IN	5 V	active-high	>3.1 V	>0.5 mA
DATA_IN	5 V	active-low	<1.5 V	<0.3 mA
DATA_IN	24 V	active-high	>16 V	>1.0 mA
DATA_IN	24 V	active-low	<10 V	<0.5 mA

4.7.10 Output modes

In all modes, the data is output during each internal PLC cycle.

Mode 1: Continuous data output (follow), no DATA_IN

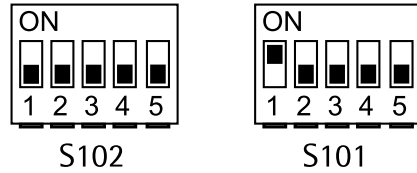

Continuous output of consistent data, provided continuously without request, e.g., for remote display.

The driver modules are always "enabled"; PIN 25 is the output.

Mode 2: Data output on external request DATA_IN (hold)

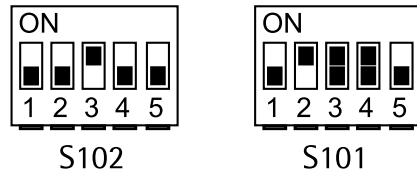

Output of consistent data in "frozen" state upon request, otherwise provided continuously.

The last output value remains frozen (hold) for as long as DATA_IN is active.

The driver modules are always "enabled"; PIN 25 (DATA_IN) is data-hold, level S101-3, polarity S101-4

Note:

The internal data transfer (data modification) on the output memory may occur at the same time that the external request signal changes from "data hold" to "data valid." This means that the requested device still has to wait 100 µs until the data is considered valid.

Mode 3: Parallel BUS system (tristate), external request DATA_IN (hold)

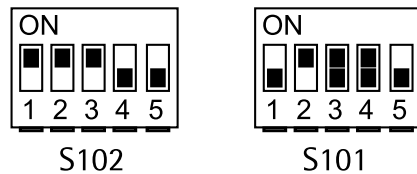

Parallel switching of n BCD cards, controlled via DATA_IN (tristate/hold) input.

Output of consistent data in "frozen" state upon request, otherwise "tristate" (highly resistant).

- The last output value remains frozen (hold) for as long as DATA_IN is active.
- The driver modules are only "enabled" (not tristate) when DATA_IN (hold) is active
- PIN 25 (DATA_IN) is data-enable+hold, level S101-3, polarity S101-4

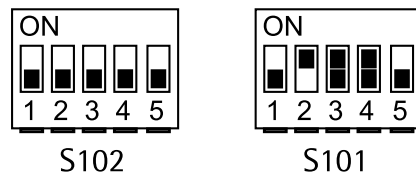
Mode 4: Continuous single-bit output (23xDA), DATA_IN (1xDE)

Continuous output of bits, provided continuously without request (1xIN, 23xOUT, configurable).

- The driver modules are always "enabled."
- PIN 25 (DATA_IN) is an input.

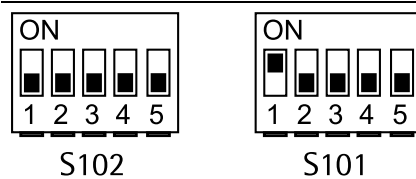
Mode 5: Continuous single-bit output (24xDA), no DATA_IN

Continuous output of bits, provided continuously without request (24xOUT, configurable).

- The driver modules are always "enabled."
- PIN 25 (DATA_IN) is an output.

4.7.11 Opto-decoupled inputs and outputs

This interface card has the type designation PR 5510/12.

The card converts the external binary signals from the process into the internal signal level and vice versa. Inputs and outputs are each bipolar potential-free.

The plug-in card has 6 passive opto-decoupled inputs and 12 passive opto-decoupled outputs. An external power supply is required.

The input signal is logically "0" when the input is open.

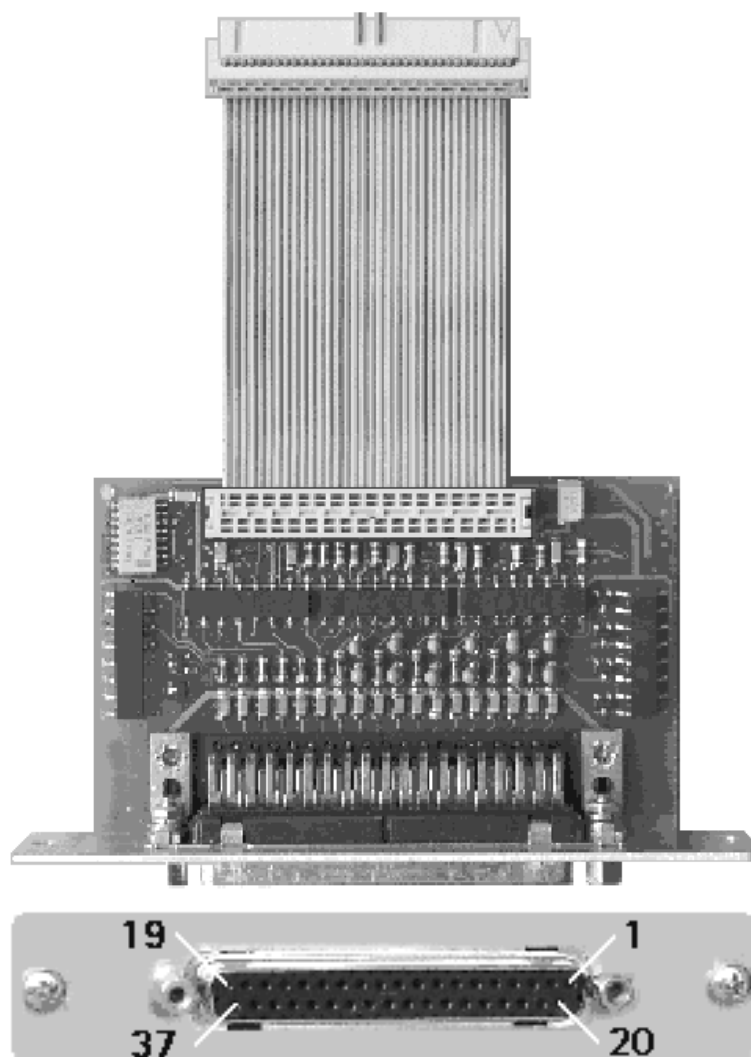

Specifications

Description	Data
Connection	D-Sub female connector, 37-pin
Input: Qty	6
Input: Voltage	Low: $U_{DC} = 0...5\text{ V}$ or open High: $U_{DC} = 10...31\text{ V}$ Passive, external power supply required
Input: Current	<7 mA @ 24 V <3 mA @ 12 V protected against incorrect polarity
Output: Qty	12
Output: Voltage	Max. switching voltage: $U_{DC} = 32\text{ V}$ Max. switching current: 25 mA Voltage drop @ 25 mA: 3 V Protected against incorrect polarity Passive, external power supply required

Description	Data
Potential isolation	Yes, via optocoupler
Cable type	Screened twisted pair (e.g. LifYCY 2x2x0.20)
Cable length	max. 50 m screened
Scope of delivery	D-Sub male connector, 37-pin Incl. shielded housings

PR 5510/12 block diagram

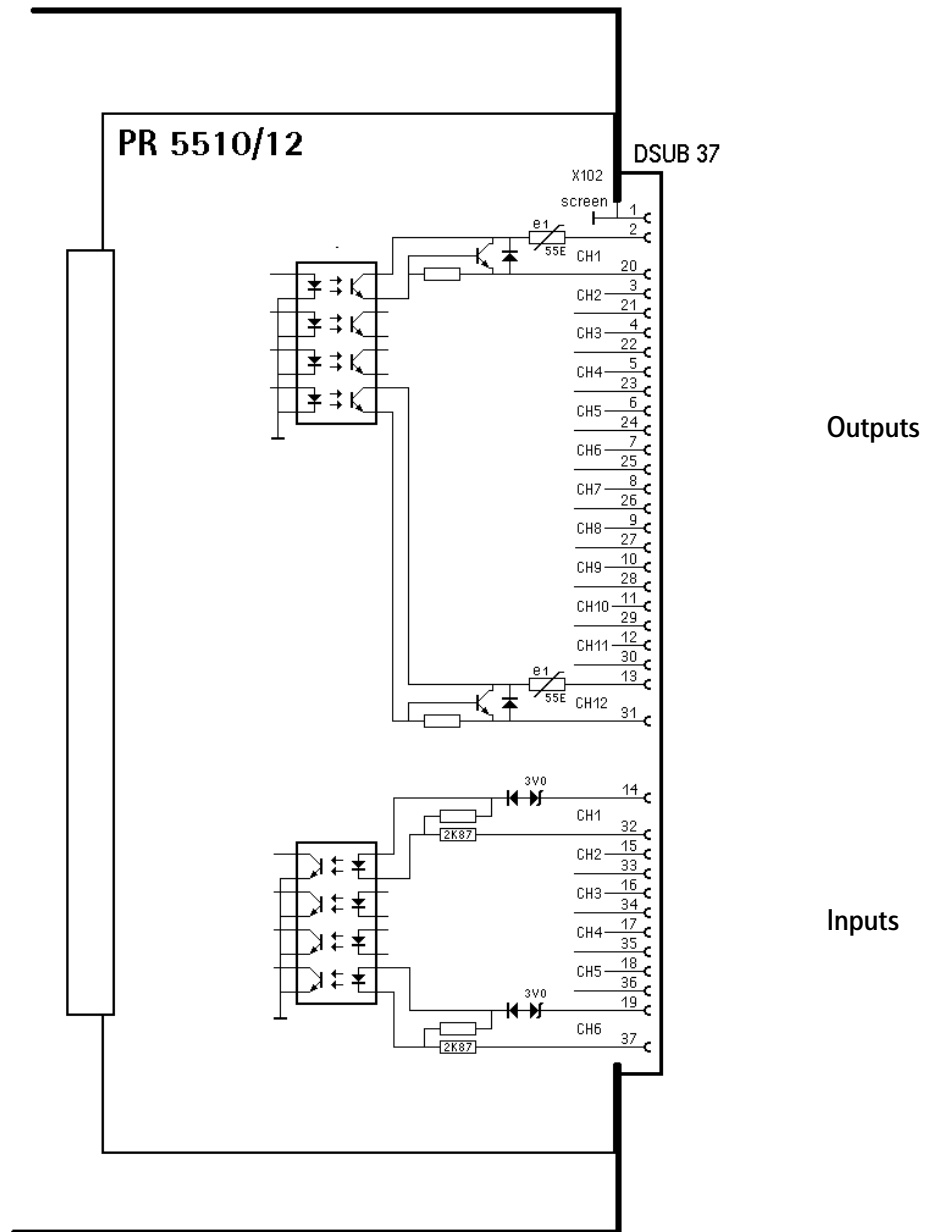

An external power supply is required: I/O channels potential-free; no shared reference

Digital inputs

Channel	CH1	CH2	CH3-CH6
Assignment	Tare/reset tare, positive flank	Print command, positive flank	Not used

Digital outputs

Channel	CH1	CH2	CH3	CH4	CH5	CH6	CH7-CH12
Assignment	"Dim" Weight is <0 or >Max.	Weight is within the zero-setting range.	Output limit 1	Output limit 2	Gross weight value is within $\pm 1/4$ d of zero	Scale error (ADC error)	Not used

Input circuitry

Contact input

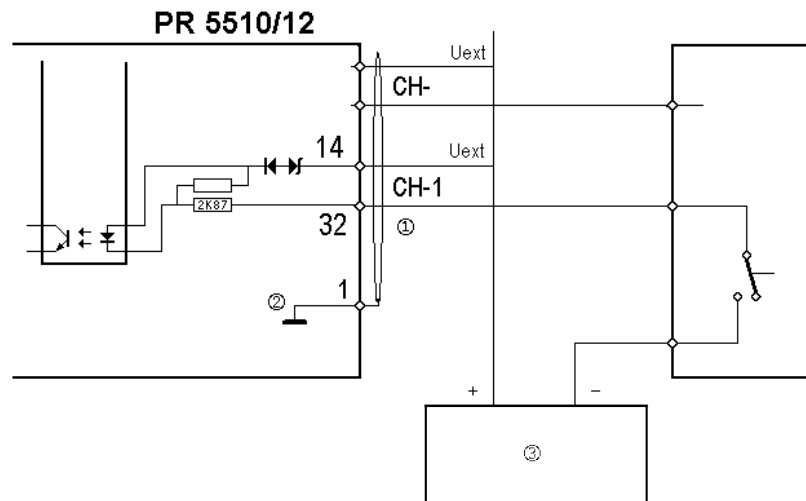

- ① input
- ② screen
- ③ supply unit $U_{DC} = 24\text{ V } 0.5\text{ A}$

Output circuitry

Voltage output

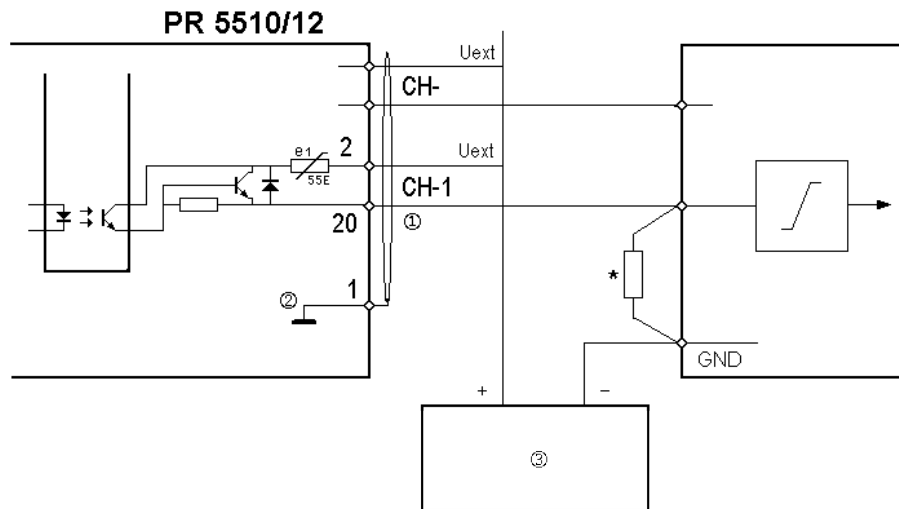

① output

② screen

③ supply unit $U_{DC} = 24\text{ V } 0.5\text{ A}$

* The load resistance must be $2.2\text{ k}\Omega/1\text{ k}\Omega$ with $24\text{ V}/5\text{ V}$.

Current output

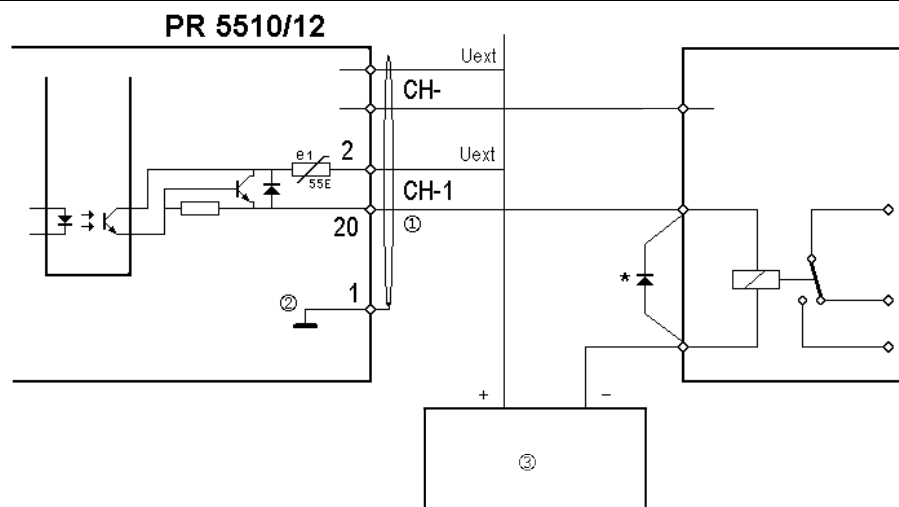

① output

② screen

③ supply unit $U_{DC} = 24\text{ V } 0.5\text{ A}$

* additional free-wheel diode for inductive loads

4.7.12 Status LEDs on fieldbus card

Watchdog LED

Frequency		Color	Meaning
Flashing	1 Hz	green	Module is initialized and ready for operation.
Flashing	2 Hz	green	Module is not initialized.
Flashing	1 Hz	red	RAM check error
Flashing	2 Hz	red	Check error in ASIC and FLASH ROM: Module is defective.
Flashing	4 Hz	red	Profibus-DP RAM check error

4.7.13 Profibus DP interface

The Profibus DP interface card has the type designation PR 1721/31.

Communication protocols and syntax comply with the Profibus-DP standard to IEC 61158, with transfer rates up to 12 Mbit/s.

Connection to the Profibus is established using the 9-pin D-Sub female connector ② on the back of the device.

The card is inserted into "Slot 4" ① (see Chapter [4.7.1](#)).

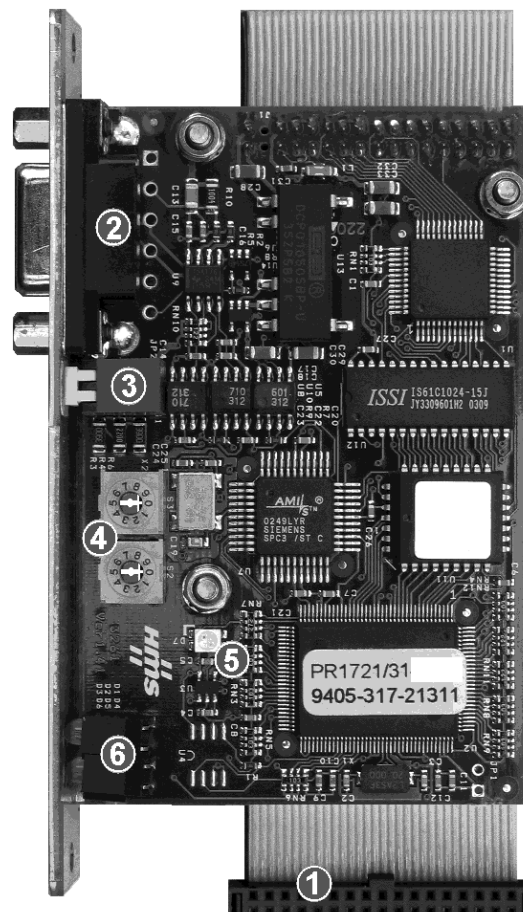

Technical data

Description	Data
Transfer rate	9.6 kbit/s to 12 Mbit/s, baud rate auto-detection
Connection mode	Profibus network, connections can be made/released without affecting other stations.
Protocol	PROFIBUS-DP-V0 SLAVE to IEC 61158 <ul style="list-style-type: none"> - Mono or multi-master systems are supported. - Master and slave devices, max. 126 nodes possible. - Watchdog Timer ⑤ (see Chapter 4.7.12)
Configuration	GSD file "SART5410.gsd"
Potential isolation	Yes, optocoupler in lines A and B (RS-485)
Bus termination	Via bus terminating resistor switch ③ (see Chapter 4.7.13.3)
Cable type	Profibus "special"; color: violet; screened twisted pair cable
Cable impedance	150 Ω
Cable length	The max. distance of 200 m can be extended at 1.5 Mbit/s by means of an additional repeater.
Certificates	Profibus test center Comdec in Germany and PNO (Profibus User Organization). Industry-compatible CE, UL, and cUL

Note:

The GSD file is stored on the CD supplied with the device (fieldbus directory of the respective device). The current file is also available to download online:

<http://www.minebea-intec.com>

Profibus connection

The device is the only/last slave in the bus:

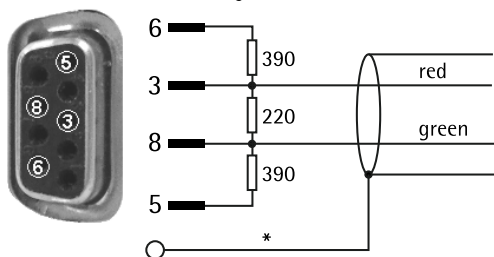

* screen on connector housing

The device is not the only/last slave in the bus:

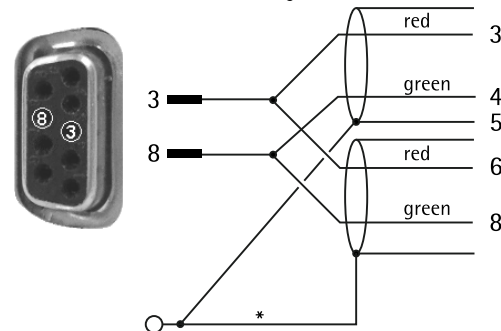

* screen on connector housing

e.g.: D-Sub bus plug SIMATIC NET PROFIBUS FAST CONNECT

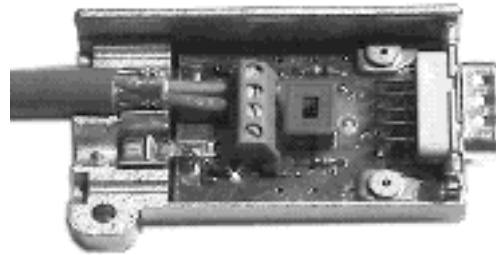

Allocation of the 9-pin D-sub female connector

Pin assignment	Signal	Color	Description
Housing -----	S		Screen
1			Not connected
2			Not connected
3 -----	RxD/TxD-P (positive) according to RS-485 specification	Red	Send/receive data Data core B/D (P)
4 if required	RTS		"Request To Send" (only when using a repeater)
5 -----	DGND		Insulated GND to RS-485 side
6 -----	VP		Insulated power supply +5 V to RS-485 side
7			Not connected
8 -----	RxD/TxD-N (negative) according to RS-485 specification	Green	Send/receive data Data core A/D (N)
9			Not connected

Note:

Only plug connections with integrated terminating resistors may be used.

4.7.13.1 Controls on fieldbus card

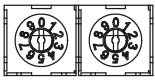

The terminating resistors can be switched on (ON) and off by pressing the bus termination switch ③; see Chapter [4.7.13.3](#).

**NOTICE**

The ④ rotary switch settings will not be used.

- ▶ Ensure that the three rotary switches for node address 1...99 are set to position "0."

Settings are defined via  - [Fieldbus parameter][Profibus-DP].

4.7.13.2 LEDs in the module cover

The module cover can be found at the rear of the device.

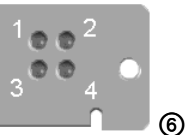
	LED 1 No function	LED 2	LED 3	LED 4
Off			No diagnostics available	
Constant green		Module is online, data transmission is possible		
Constant red				Module is offline
Flashing 1 Hz red			I/O length configuration error	
Flashing 2 Hz red			Parameter, data length error	
Flashing 4 Hz red			Communication, ASIC error	

4.7.13.3 Bus termination

The end nodes in a Profibus-DP network must be fitted with termination resistors, to prevent reflections in the bus cable.



Bus termination switch ③ is located in the module cover and can be accessed from outside.

Bus termination switch "ON"	The bus termination is switched on. If the module is the last or first in the network, this switch must be set to "ON." An "external" terminating resistor can also be used in the Profibus connector, however.
Bus termination switch "OFF"	The bus termination is switched off. When using an external terminating resistor in the Profibus connector, the switch on the module cover must be in position "OFF."

4.7.13.4 Connection diagram for a master with three slaves

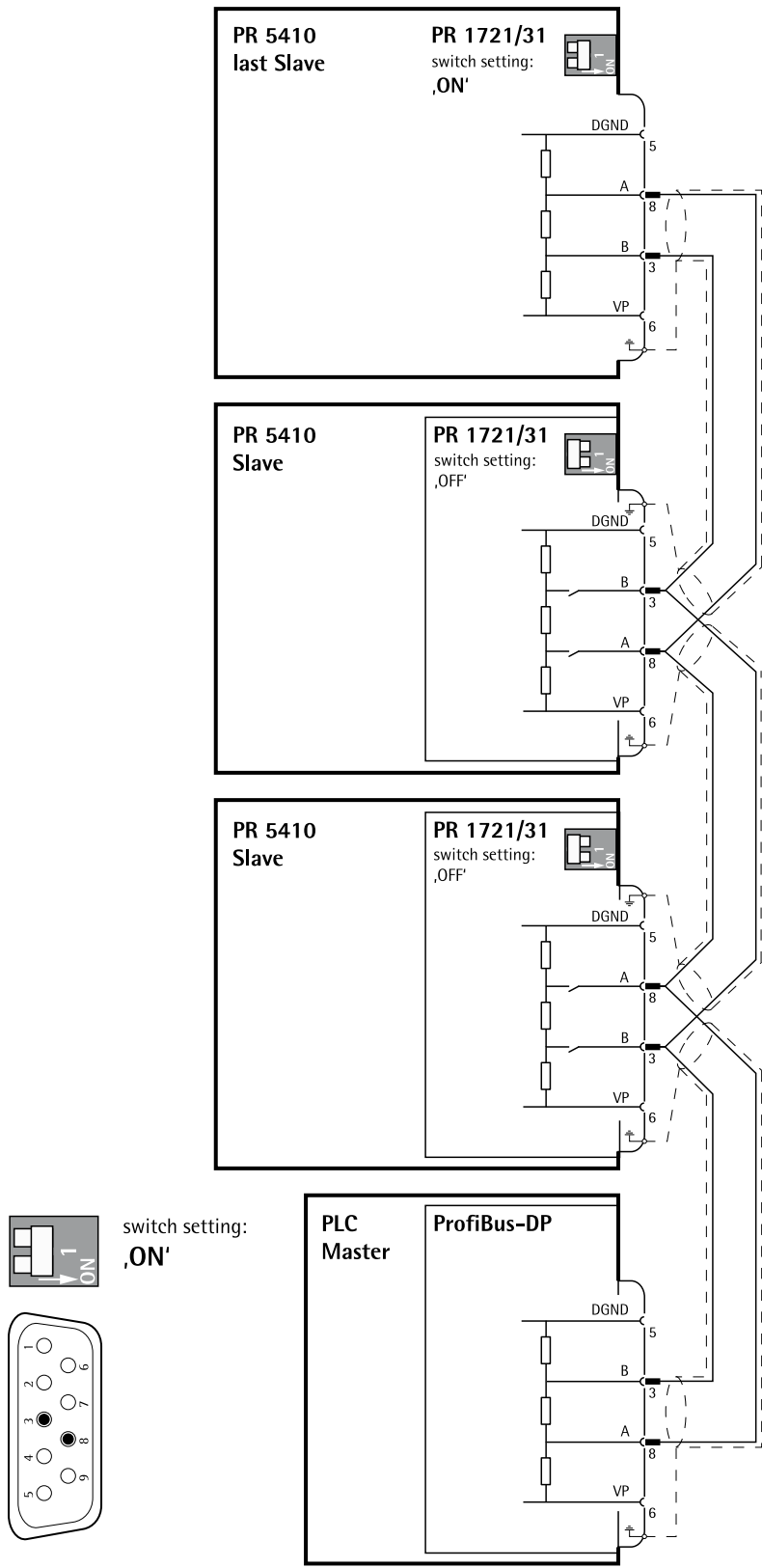

4.7.14 InterBus-S interface

The InterBus-S interface card has the type designation PR 1721/32.

The interface is based on the InterBus chip technology and enables transfer rates of 500 kbit/s.

The InterBus-S connection is established by the 9-pin D-Sub male connector (IN) ② and the 9-pin D-Sub female connector (OUT) ③ on the back of the device.

The card is inserted into "Slot 4" ① (see Chapter [4.7.1](#)).

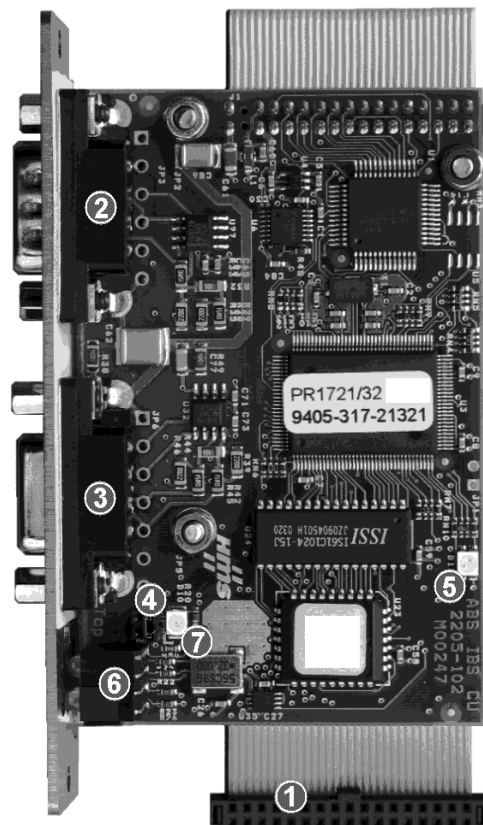

Specifications

Description	Data
Transmission rate	500 kbit/s or 2 Mbit/s, switchable ④
Protocol	Interbus-S master–slave <ul style="list-style-type: none"> - Fixed telegram length - Deterministic cyclical process data transmission with max. 10 words I/O. - Watch-Dog Timer ④ (see Chapter 4.7.12)
Potential isolation	Yes, optocoupler and DC/DC converter
Lead termination	Not required, due to active ring topology
Cable type	InterBus; color: green; 3x2 twisted pair; screened
Cable impedance	150 Ω

Description	Data
Cable length	400 m (between two remote bus subscribers); overall length: 13 km
Certificates	From INTERBUS CLUB e.V.: <ul style="list-style-type: none"> - Compatibility with InterBus standard. - IEC 61158 (Parts 3 to 6), EN 50254 (DIN 19258) - Industry-compatible CE, UL and cUL

InterBus-S connections

Bus "IN"

Bus "OUT"

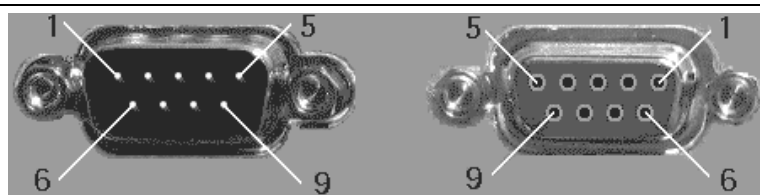

Example: Phoenix Contact IBS RTC-T

Allocation of the 9-pin D-sub male connector "IN" ②

Pin allocation acc. to DIN 41642	Signal	Color acc. to DIN 47100	Description
Cable sheath		pea green	Special InterBus cable (certified)
Housing	S		Screen
1-----	DO1	yellow	not inverted, data output
2-----	DI1	gray	not inverted, data input
3-----	GND	brown	signal ground
4			not connected
5-----*	GND		signal ground (continuation jumper: 5-9)
6-----	IDO1	green	inverted, data output
7-----	IDI1	pink	inverted, data input
8			not connected
9-----*	RBST		(continuation jumper: 5-9)

* only if necessary

Allocation of the 9-pin D-sub female connector "OUT"③

Pin allocation acc. to DIN 41642	Signal	Color acc. to DIN 47100	Description
Cable sheath		pea green	Special InterBus cable (certified)
Housing	S		Screen
1-----	DO1	yellow	not inverted, data output
2-----	DI1	gray	not inverted, data input
3-----	GND	brown	signal ground
4			not connected
5			not connected
6-----	IDO1	green	inverted, data output
7-----	IDI1	pink	inverted, data input
8			not connected
9			not connected

* only if necessary

4.7.14.1 LEDs in the module cover

The module cover can be found at the rear of the device.

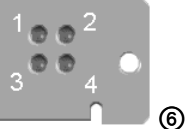
	LED 1 CC/RC	LED 2 BA	LED 3 RD	LED 4 TR
Off				
Constant green	Cable OK, no reset mode in the master	Bus is active		PCP communication is active, hold = 500 ms
Constant red			Remote bus is not active	

4.7.14.2 Selecting the status LED and transfer rate

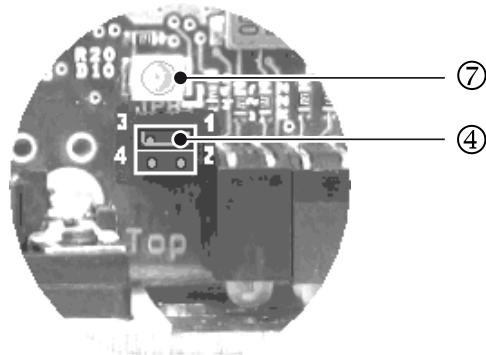

LED ⑦ lights up when the operating voltage is applied.

The transfer rate is selected using the 2-pole jumper ④.

- 3 – 1 = 2 Mbit/s
- 4 – 2 = 500 kbit/s

The selection is saved only by switching on the supply voltage.

4.7.14.3 Connection diagram for a master with three slaves

NOTICE

At bus "OUT" ③, pins 5 and 9 must be bridged if another slave follows.

► See connection diagram.

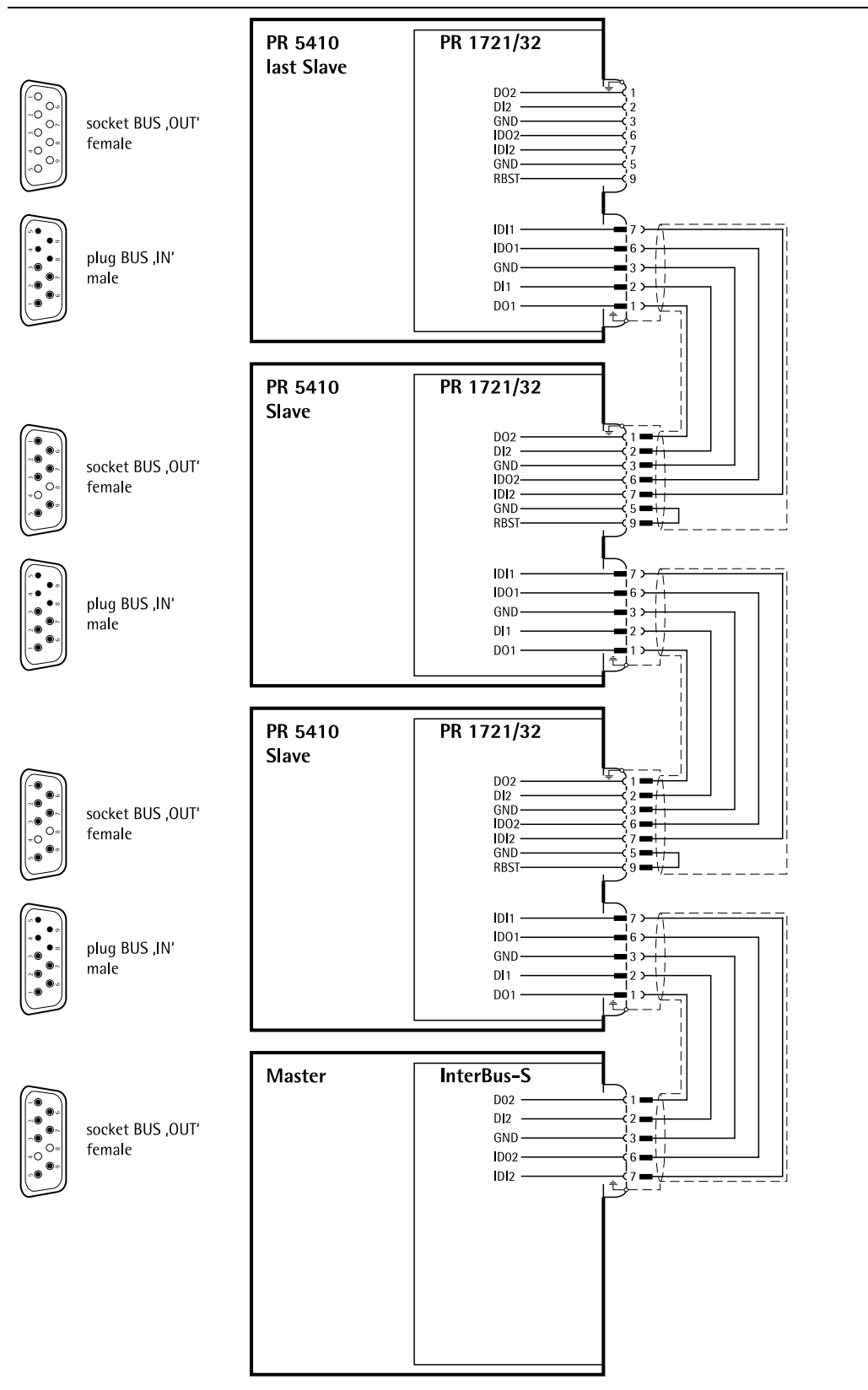

4.7.15 DeviceNet interface

The DeviceNet interface card has the type designation PR 1721/34.

The fieldbus card contains all functionalities to make a complete DeviceNet slave with a CAN controller and transmission speeds up to 500 kbit/s.

The DeviceNet connection is established by 5-pin terminal ②.

The card is inserted into "Slot 4" ① (see Chapter [4.7.1](#)).

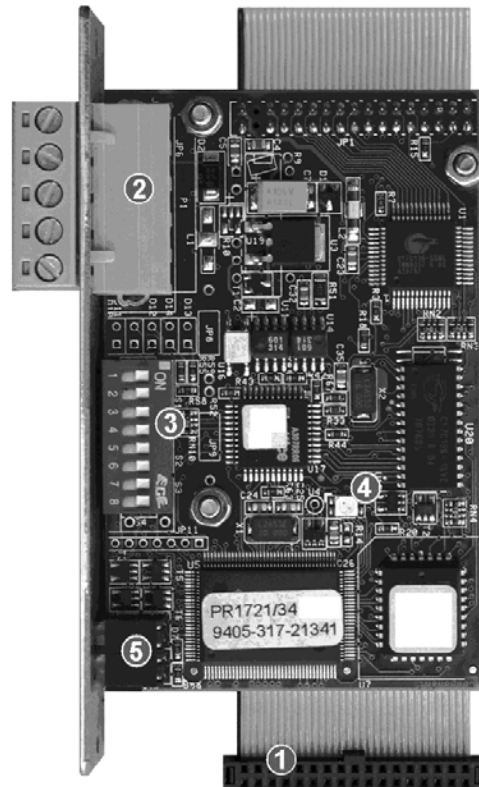

Technical data

Description	Data
Transfer rate	125, 250 and 500 kbit/s
Protocol	DeviceNet Master Slave <ul style="list-style-type: none"> - Polling procedure (polled IO) - CRC error recognition according to IEC 62026 (EN 50325) - Max. 64 station nodes - Data width max. 512 byte "input & output" - Watchdog Timer ④ (see Chapter 4.7.12)
Configuration	EDS file "sag_5410.eds" MAC-ID (1...62)
Potential isolation	Yes, optocoupler and DC/DC converter
Bus termination	120 Ω at the cable ends
Bus load	33 mA @ U _{DC} = 24 V

Description	Data
Cable type	DeviceNet; color: petrol green; 2x2 twisted pair; screened
Cable impedance	150 Ω
Cable length	Depends on cable type and transmission rate: 100 to 500 m
Certificates	<ul style="list-style-type: none"> - Compatible with DeviceNet specification Vol. 1: 2.0, Vol 2: 2.0 - ODVA Certificate according to conformity test software version A-12 - Industry-compatible CE, UL, and cUL

Note:

The EDS file is stored on the CD supplied with the device (fieldbus directory of the respective device). The current file is also available to download online:

<http://www.minebea-intec.com>

DeviceNet terminal

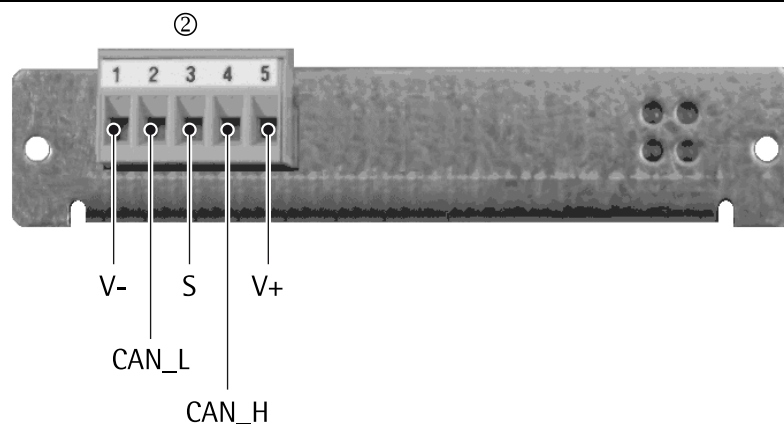

Allocation of the 5-pin terminal

Pin assignment	Signal	Color	Description
Cable sheath			Special DeviceNet cable (certified)
1-----	V-	black	Negative power supply
2-----	CAN_L	Blue	CAN_L bus signal
3-----	S		Cable screen
4-----	CAN_H	white	CAN_H bus signal
5-----	V+	Red	Positive power supply

4.7.15.1 Controls on fieldbus card

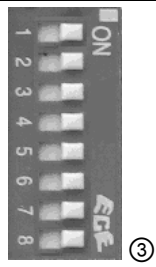

NOTICE

The ③ DIL switch settings will not be used.

- ▶ Make sure that the switches 1...8 are set to position "ON."

Settings are defined via  - [Fieldbus parameter].

4.7.15.2 LEDs in the module cover

The module cover can be found at the rear of the device.

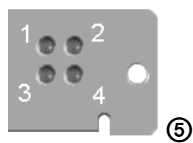

LED 1
No function

LED 2
Network status

LED 3
No function

LED 4
Module status

Off	No power		
Constant green	Link detected; online and connected		Module is working
Flashing green	Online, not connected		Data length > configuration
Constant red	Critical link error		Fatal error
Flashing red	Connection timeout		Minor error

4.7.15.3 Connection diagram for a master with three slaves

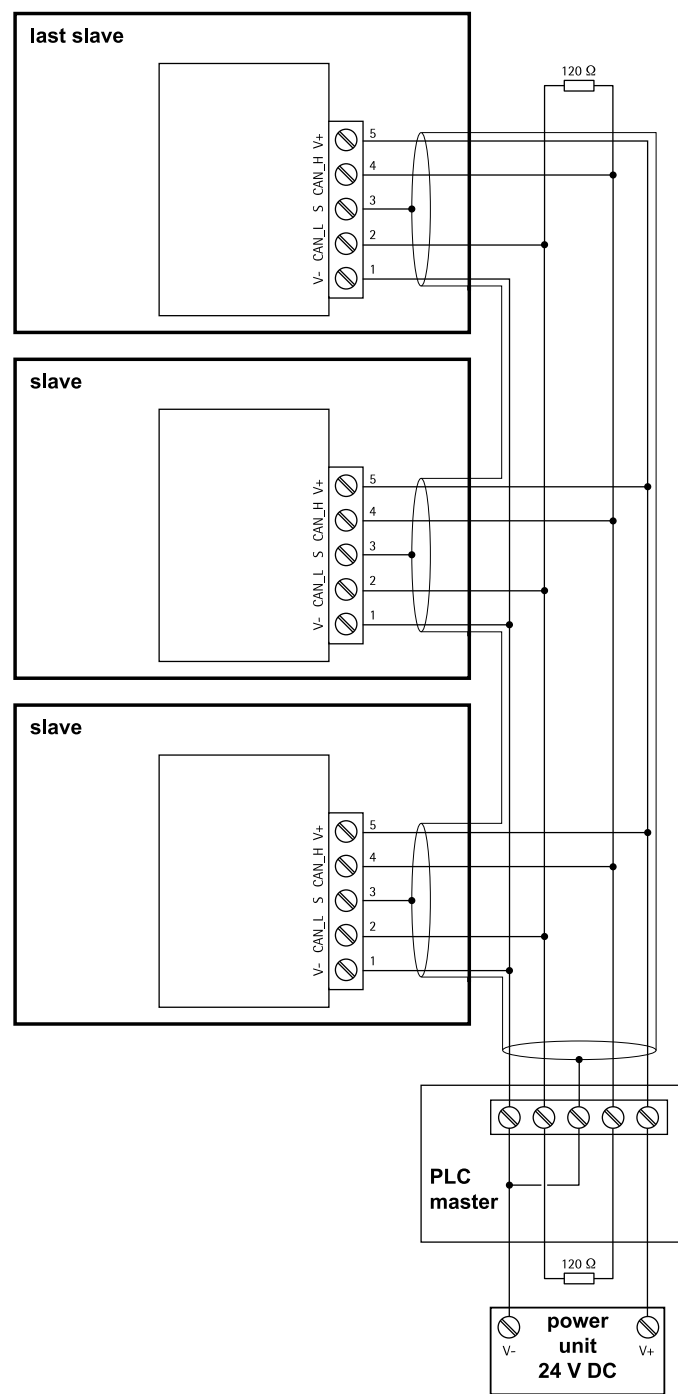

4.7.16 CC-Link interface

The CC-Link interface card has the type designation PR 1721/35.

The fieldbus card contains all functions to provide a complete CC-Link slave with transfer rates up to 10 Mbps.

The CC-Link connection is established by the 5-pin terminal ②.

The card is inserted into "Slot 4" ① (see Chapter 4.7.1).

Note:

This fieldbus card does **not** support the "EasyFill" application.



Technical data

Designation	Data
Transfer rate	156; 625 kbps; 2.5; 5, 10 Mbps
Protocol	CC-Link slave <ul style="list-style-type: none"> - CRC error recognition according to IEC 62026 (EN 50325) - Max. 64 station nodes - 128 I/O bits and 16 (32 bit) words - Watchdog Timer ④ (see Chapter 4.7.12)
Configuration	CSP file "PR1721_1.csp"
Potential isolation	Yes, optocoupler and DC/DC converter

Designation	Data
Bus termination	110 Ω at the cable ends
Bus load	100 mA
Cable type	2x2 screened twisted pair
Cable length	100 m @ 10 Mbps, 1200 m @ 156 kbps
Certificates	- Type: ABS-CCL (H/W: 1.01, S/W: 2.00.05, CC-Link: 2.0) - Reference no. 372

Note:

The CSP file is stored on the CD supplied with the device (Fieldbus directory of the respective device). The current file is also available for download via the Internet:

<http://www.minebea-intec.com>

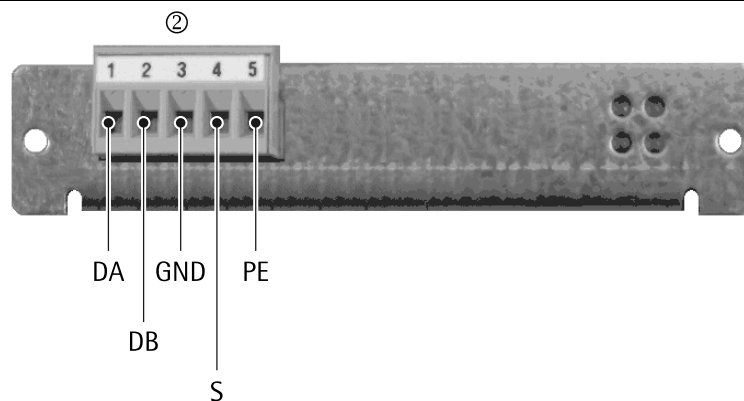
CC-Link terminal**Allocation of the 5-pole terminal block**

Pin assignment	Signal	Description
1 -----	DA	Communication RS-485 RxD/TxD (+)
2 -----	DB	Communication RS-485 RxD/TxD (-)
3 -----	GND	Digital ground
4 -----	S	Cable screen
5 -----	PE, according to AnyBus S-specification	Housing ground

4.7.16.1 Controls on fieldbus card



NOTICE

The ③ rotary switch settings will not be used.

- ▶ Ensure that the three rotary switches (station no. and baud rate) are set to position "9."

This setting is defined via  - [Fieldbus parameter] [CC-Link].

4.7.16.2 LEDs in the module cover

The module cover can be found at the rear of the device.

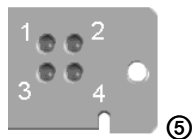

	LED 1 No function	LED 2 Network status	LED 3 No function	LED 4 Module status
Off	<ul style="list-style-type: none"> - No power supply - "Timeout" - No connection (HW) 	<ul style="list-style-type: none"> - No power supply - Normal function 	<ul style="list-style-type: none"> - No power supply - No transmission data 	<ul style="list-style-type: none"> - No power supply - No data reception
Constant green	Normal function		Send data	Receive data
Constant red		<ul style="list-style-type: none"> - CRC error - No admissible station - No admissible baud rates 		

4.7.17 ProfiNet I/O interface

The ProfiNet I/O interface card has the type designation PR 1721/36.

The fieldbus card is equipped with a standard RJ-45 socket ② for network connection. It contains powerful UDP/IP connecting circuitry with transfer rates of 10 and 100 Mbit/s. The card is inserted into "Slot 4" ① (see Chapter 4.7.1).



Technical data

Description	Data
Transfer rate	10 Mbit/s and 100 Mbit/s Auto-detection (100, FullDX)
Protocol	ProfiNet I/O
Connection mode	Network
Configuration	XML file "GSDML-Vx.xx-Sartorius-PR5410-xxxxxx.xml"
Potential isolation	Yes
Cable type	Twisted pairs, screened, e.g., patch cable CAT5 Autolink (straight or crossover)
Cable impedance	150 Ω
Cable length to HUB	Max. 115 m
Certificate	ProfiBus Nutzerorganisation e.V. for HMS Industrial Networks AB Certificate no.: Z10931

Note:

The ProfiNet I/O card is supported by PR 5410 firmware release 1.40 or higher.

The IP address and subnet mask are set under  - [Fieldbus parameters] (refer also to Chapter 7.18.5 and 12.2)

The XML file is stored on the CD supplied with the device (fieldbus directory of the respective device). The current file is also available to download online:

<http://www.minebea-intec.com>

Note:**Fieldbus parameters**

Recommendation for a Siemens S7, for example

- ▶ Fieldbus slave setting:
- ▶ Use DHCP [on] as per the default settings and activate the master as a DHCP server (W [Allocate IP adr via IO controller]).

NOTICE**Slave – master device names**

A unique device name must be assigned out of the master. This name is given highest priority when establishing a connection.

- ▶ When replacing devices or servicing, please note:
- ▶ As well as the IP address, the device name must correspond to that of the replacement device. Explicit assignment out of the master is required.

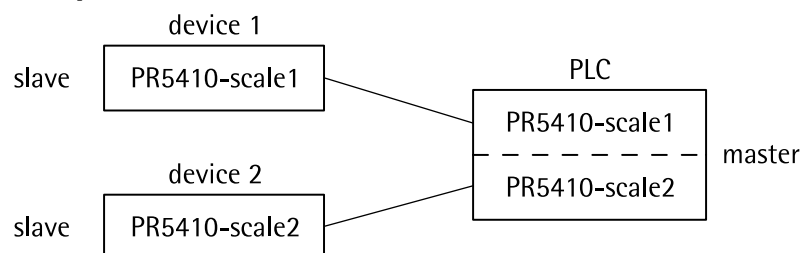
Example:

4.7.17.1 LEDs in the module cover

The module cover can be found at the rear of the device.

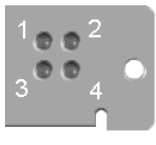
	LED 1	LED 2	LED 3 No function	LED 4
Off	No connection (HW)	Offline, no connection		Not initialized
Constant green	Connection (HW)	Online, link established		Initialized, no error
Flashing green	Send/receive data	Online in stop		
Flashing green, quickly				Engineering tool for identification is active
Flashing red				Configuration error, no station name/IP address, internal error

4.7.18 EtherNet/IP interface

The EtherNet/IP interface card has the type designation PR 1721/37.

The fieldbus card is equipped with a standard RJ-45 socket ② for network connection. It contains powerful UDP/IP connecting circuitry with transfer rates of 10 and 100 Mbit/s.

The card is inserted into "Slot 4" ① (see Chapter 4.7.1).

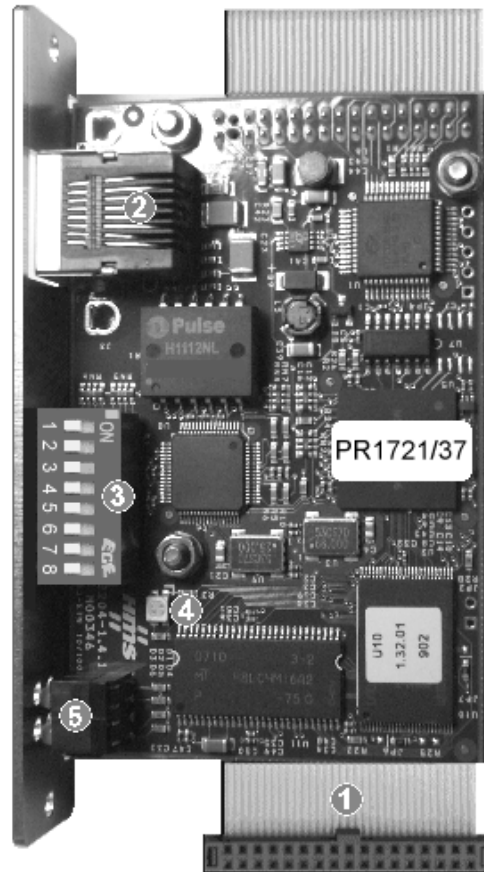

Technical data

Description	Data
Transfer rate	10 Mbit/s and 100 Mbit/s Auto-detection (100, FullDX)
Protocol	EtherNet IP
Connection mode	Network
Configuration	EDS file "sag_5410_ethernetip.eds"
Potential isolation	Yes
Cable type	Twisted pairs, screened, e.g., patch cable CAT5 Autolink (straight or crossover)
Cable impedance	150 Ω
Cable length to HUB	Max. 115 m

Description	Data
Certificate	EtherNet IP specification <ul style="list-style-type: none"> - ODVA file no. 10286 - Test date: 9/6/2005 - Vendor ID 90 - See also: www.odva.org - Industry-compatible CE, UL, and cUL

Note:

The EtherNet/IP card is supported by PR 5410 firmware release 1.30 or higher.

The IP address and subnet mask are set under  - [Fieldbus parameters] (refer also to Chapter [7.18.5](#) and [12.2](#))

The EDS file is stored on the CD supplied with the device (fieldbus directory of the respective device). The current file is also available to download online:

<http://www.minebea-intec.com>

4.7.18.1 Controls on fieldbus card**NOTICE**

The ③ DIL switch settings will not be used.

- ▶ Make sure that the switches 1...8 are set to position "OFF."

Settings are defined via  - [Fieldbus parameter].

4.7.18.2 LEDs in the module cover

The module cover can be found at the rear of the device.

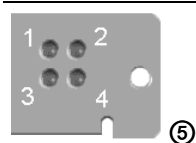

	LED 1	LED 2	LED 3	LED 4
Off	No connection (HW)	No power		No power or no IP address
Constant green	Connection (HW)	Controlled by scanner		"Online," link established
Flashing green		Not configured, or scanner not active	Packet is received or transmitted	"Online," no link established
Constant red		Fatal error		Duplicate IP address, major error
Flashing red		Minor recoverable error		Connection timeout
Alternating red/green		Self-test running		Self-test running

5 "Standard" application

5.1 Functions

5.1.1 General information

The "Standard" application supports the weighing functions of the device.
Filling is not possible.

5.1.2 Display functions

- Display of gross, net or tare weight
- Tare/reset tare
- Set gross to zero
- Print weight
- Display of weight values or remote display
- Functions via digital inputs and outputs
- Information interchange via serial I/O, fieldbus and network

6 "EasyFill" application

6.1 Functions

6.1.1 General information

The "EasyFill" application is used for the batching of single components.

The application allows for quick and reliable filling and emptying of vessels.

The dosing process can be started, stopped, interrupted and restarted via the front-panel keys, VNC user interface, digital inputs, OPC/Modbus and field bus (except for CC link).

6.1.2 Display functions

- Display of gross, net or tare weight
- Tare/reset tare
- Set gross to zero
- Print weight
- Display of weight values or remote display
- Functions via digital inputs and outputs
- Information interchange via serial I/O, fieldbus and network

6.1.3 Filling mode

The "EasyFill" application supports the following filling modes:

- Net filling "B1"
- Net discharge "B4"

6.2 Application menu [Start]

Filling	
— Material ID	Material identification Selection: ID 1...10
— Material name	Material name Input: max. 18 alphanumeric characters
— Set point	Set point Input: weight; adopt unit from the calibration.
— Preset	Preset point for switching from coarse flow to fine flow. Input: weight; adopt unit from the calibration.
— Overshoot (OVS)	Material overshoot Input: Weight; adopt unit from the calibration.
— +/- tolerance	Tolerance above/below set point Input: tolerance values; adopt unit from the calibration.
— Calming time	Calming time Input: in ms
— Start	Start filling.
— Stop	Stop filling.
— Restart	Restart filling.
— Abort	Abort filling.

Configuration	
Configuration mode	Configure the mode
Dosing mode	Filling mode Selection: Net filling (B1), Net Discharge (B4)
Interaction mode	Interaction mode Selection: Remote proc. control, VNC, Front keys
Print	Print configuration.
Configuration digital I/Os	
Configuration digital inputs	Configure digital inputs
1...3: SPM address %MX	Input: SPM address, see Chapter 13.4
Print	Print configuration.
Configuration digital outputs	Configure digital outputs
1...3: SPM address %MX	Input: SPM address, see Chapter 13.4
Print	Print configuration.
Configuration material	
Material ID	Material identification Selection: ID 1...10
Material name	Material name Input: max. 18 alphanumeric characters
Set point	Set point Input: weight; adopt unit from the calibration.
Preset	Preset point for switching from coarse flow to fine flow. Input: weight; adopt unit from the calibration.
Overshoot (OVS)	Material overshoot Input: weight; adopt unit from the calibration.
+/- tolerance	Tolerance above/below set point Input: tolerance values; adopt unit from the calibration.
Calming time	Calming time Input: in ms
Default	Reset values to 0.
Print all	Print all ID entries.
Print	Print selected ID entry.
Configuration printing	
Number printouts	Number of printouts Input: 1...10
Sequence number	Sequence number, see Chapter 8.4.4 .
Use NLE	Use NLE Check the <input checked="" type="checkbox"/> box to activate printing with NiceLabelExpress.
Line 1...6	Line 1...6 Selection: see Chapter 8.4.4
Print	Print configuration.

7 Getting started

7.1 Power failure/Data backup/Restart

7.1.1 Power failure

If the grid power fails,

- all entered configuration and calibration parameters and
 - all the materials written on the built-in memory
- are saved.

The clock and the calendar continue to run.

7.1.2 Data backup

The calibration data and parameters as well as all configuration and interface data are stored in non-volatile (EARAM) memory.

Unauthorized data changing can be prevented by an access code.

The front-panel keys can be disabled.

Additional write protection is provided for calibration data and parameters (see Chapter [7.1.3.1](#)).

7.1.3 Overwrite protection

7.1.3.1 CAL switch

The CAL switch protects the calibration data and parameters against unauthorized access. The CAL switch is located on the back of the device.

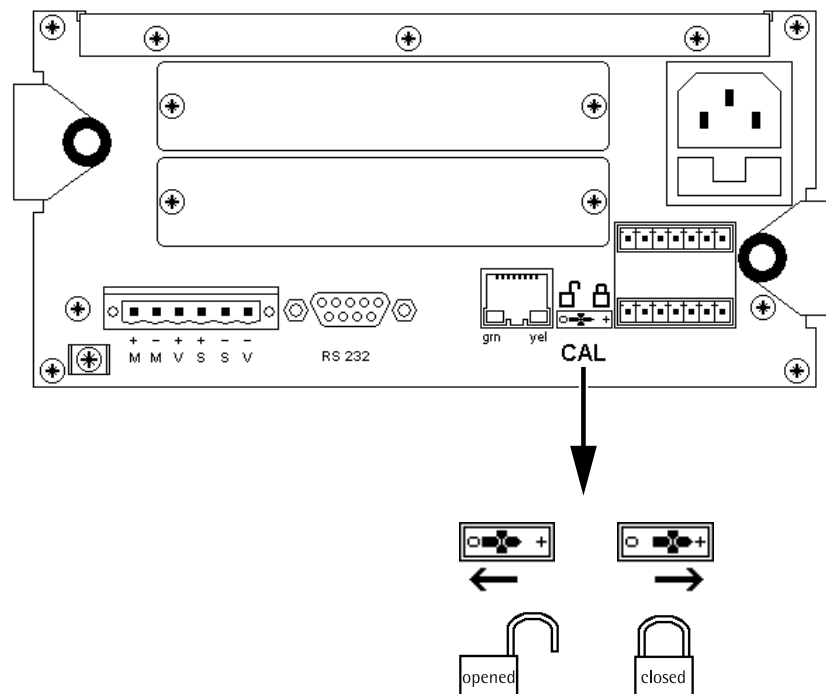

When the CAL switch is in "opened" position, the calibration data and parameters can be changed using the PC program or via the ProfiBus connection.

With the CAL switch in the "closed" position, the calibration data (e.g. dead load, SPAN) and parameters (measuring time, zero tracking etc.) cannot be changed.

With legal-for-trade applications, the CAL switch must be sealed in the closed position.

Note:

If the weighing electronics board has been changed after calibration or the device is not calibrated the weight value display will show "Error 15" if the CAL switch is closed.

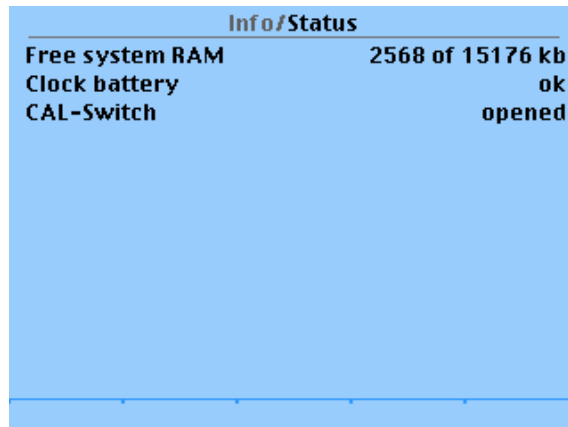

The position of the CAL switch is shown with VNC/WEB browser under  – [Show status]:

[opened] = opened, no write protection.

[closed] = closed, write protection is active.

7.1.3.2 Factory settings









Calibration data <default>	Calibration parameters <default>
Full Scale (FSD) (Max) <3000> <k-g>	Measurement time <160> ms
Scale interval <1>	Digital filter <off>
Dead load <0.000000> mV/V	Test mode <absolute>
SPAN <1.000000> mV/V	W&M* <none>
	Standstill time <0.5> s
	Standstill range <1.00> d
	Zero range <50.00> d
	Zerotrack range <0.25> d
	Zerotrack step width <0.25> d
	Overload (range over Max.) <9> d
	Min <20> d

* The parameter [W&M] must be selected before entering the calibration data or must be set to [none] = "off", see Chapter [7.14.15](#).

7.1.4 Restart

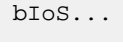
The PR 5410 is restarted using the front-panel keys.

Press the following keys one after the other:

-   appears on the display.
- /↓  appears on the display.
- /OK  appears on the display.
-  follows on the display.
- /↓  appears on the display.
- /OK

Restarting has the following effects on the device:



- Current process steps are deleted.
- The device is reset to its factory settings.
- The network settings are not changed.

7.2 Switching on the device

The device can be set up as follows:

- Via keys on the front of the device
- Via a notebook/PC using the VNC software (included on the CD)
- Via a notebook/PC using an Internet browser

When the device is powered up, the following is shown on the display:

Pr5410	The instrument type is displayed, PR 5410
b 1.00.00.	BIOS version
F 1.00.00.	Firmware version
	Automatic display test
	Weight display

Error6	Error message, if no sense voltage is connected, see also Chapter 16.1 .
Error9	Error message: if there is no communication with the xB-PI scale (see also Chapter 16.2). Error message: unable to read weight values from the ADU (analog-digital converter); see also Chapter 16.1 .

The weight display is shown.







Check the date and time after first turning on the device, see Chapter [7.2.1](#).

7.2.1 Setting the date and time

Entering the date and time via Notebook/PC (VNC/WEB browser)

See Chapter [7.18.2](#).

Entering the date and time using the front-panel keys

1. Press .
 - ▷ `SEtUP` appears on the display.
2. Press "OK."
 - ▷ `Cd 000` appears on the display ("Cd" flashes).
3. Press  repeatedly (9x) until "dt 086" appears.
4. Press "OK."
 - ▷ `YEAr` appears on the display.
5. Press "OK."
 - ▷ `2007` (YYYY) is displayed.
6. Use  and  to make changes accordingly.
7. Press "OK."
 - ▷ `dAtE` appears on the display.
8. Press "OK."
 - ▷ `05/15` (MM/DD) appears on the display.
9. Use  and  to make changes accordingly.
10. Press "OK."
 - ▷ `tIME` appears on the display.
11. Press "OK."
 - ▷ `17.35` (SS.MM) appears on the display.

12. Use ←/→ and ↑/↓ to make changes accordingly.
13. Press "OK."

▷ dt 086 appears on the display.

14. Press "Exit" to exit the menu.

7.3 Switching off the device

The device is switched off/disconnected from power supply by pulling the plug.

7.4 Warm-up time

The device requires a warm-up time of 30 minutes before calibration.

7.5 Configuring and calibrating using the front-panel keys

The device can be configured directly using the front-panel keys, with the exception of the connected xBPI weighing point.

Note:

If an xBPI weighing point is selected, "Err86" appears on the display and it can only be calibrated via VNC.

7.5.1 Parameter table (SEtuP)

<p>— CD*</p> <ul style="list-style-type: none"> — 000 CALib — 001 MAX.FSd — 002 StEP — 003 dEAdLo — 004 SPAn — 005 0-rnG — 006 uVolt.d — 007 WEIGHt 	<p>Calibration data nEW new calibration, VIEW display data, Mod modify calibration Decimal point position, Max (scale range) and weight unit Scale interval Set dead load with weight (LoAd) or mV/V (MVoLt) Calibrate range with weight (LoAd) or mV/V (MVoLt) Display the used zero-setting range Display $\mu\text{V}/\text{d}$ Display current gross weight; 10-fold resolution is possible using  key.</p>
<p>— CP*</p> <ul style="list-style-type: none"> — 010 MEAtIM — 011 FILtEr — 012 FCut — 013 tStMod — 014 WAM — 015 StStIM — 016 StSrNG — 017 TArtIM — 018 ZESrNG — 019 ZEtRN 	<p>Calibration parameter Measurement time Digital filter Filter frequency Test mode W&M, legal-for-trade Standstill time Standstill range Timeout for taring/zero-setting Zeroset range Zero-track range</p>

—	—	020 ZEtStP	Zerotrack interval
—	—	021 ZEtTm	Zerotrack time
—	—	022 oVrLd	Overload
—	—	023 MIn	Min.
—	—	024 MuLrnG	Multi-range mode
—	—	025 rAnG 1	Range 1
—	—	026 rAnG 2	Range 2
—	LI		Limits (settings via VNC), for Standard application only
—	—	030 LIM.1on, LIM.1oF	Limit 1 "On", limit 1 "Off"
—	—	031 LIM.2on, LIM.2oF	Limit 2 "On", limit 2 "Off"
—	—	032 LIM.3on, LIM.3oF	Limit 3 "On", limit 3 "Off"
—	LA		Limits, action/condition (settings via VNC), for Standard application only
—	—	033 LIM.1on	Action/condition
—	—	034 LIM.1oF	Action/condition
—	—	035 LIM.2on	Action/condition
—	—	036 LIM.2oF	Action/condition
—	—	037 LIM.3on	Action/condition
—	—	038 LIM.3oF	Action/condition
—	do		Digital outputs (settings via VNC), for Standard application only
—	—	040 bCd.out	BCD mode: GroSS; NETlt = net if tared, otherwise gross; SELEct; trnSP
—	—	041 outP. 1	Output 1
—	—	042 outP. 2	Output 2
—	—	043 outP. 3	Output 3
—	dl		Digital inputs (settings via VNC), for Standard application only
—	—	044 InP.1on	Input 1, condition
—	—	045 InP.1oF	Input 1, condition
—	—	046 InP.2on	Input 2, condition
—	—	047 InP.2oF	Input 2, condition
—	—	048 InP.3on	Input 3, condition
—	—	049 InP.3oF	Input 3, condition
—	Ao		Analog output, for Standard application only
—	—	050 AnA.Mod	Mode: GroSS; NETlt = net if tared, otherwise gross; SELEct; trnSP
—	—	051 AnA.rnG	Range 0/4–20 mA
—	—	052 out.Err	Output on error
—	—	053 out.< 0	Output if <0
—	—	054 out.>20	Output if >Max
—	—	055 Wgt.0/4	Weight if 0/4 mA
—	—	056 Wgt. 20	Weight if 20 mA
—	oP		Operating parameters
—	—	060 Addr	Device address, for Standard application only
—	—	061 Pln	Access code, for Standard application only
—	—	062 ALIbl	Alibi, nonE, GroSS, nEt, Gr.nE.tA., Gr.nE. or Gr.tA
—	—	063 SEqnr	Next free sequence number

—	064 tArKEY	Tare key, function, disable
—	065 ZErKEY	Zeroset key, function, disable
—	066 nbtKEY	N.B.T key, disable
—	067 PrtKEY	Print key, disable
—	068 tStKEY	Test key, disable
—	PP	Print parameters
—	073 PrtMod	LAYout (direct)/nICELb (Nice Label)
—	074 LAYou1	Select element 1
—	075 LAYou2	Select element 2
—	076 LAYou3	Select element 3
—	077 LAYou4	Select element 4
—	078 LAYou5	Select element 5
—	079 LAYou6	Select element 6
—	nP	Print parameters
—	080 dHCP	DHCP
—	081 IP.Addr	IP address
—	082 SubnEt	Subnet
—	083 Gt.Addr	Gateway
—	084 CLIEnt	VNC client
—	085 Et.Addr	Hardware address (MAC ID) This address is also located on the label on the side of the device; see Chapter 7.9 .
—	dt	Date and time
—	086 YEAr	YYYY, dAtE: MM-TT, tIME: HH.MM
—	VS	Program versions
—	087 FirM	Firmware
—	088 bloS	Bios
—	089 boArd	Board number
—	FP	Fieldbus parameters
—	090 Prot	Protocol (e.g., [Pro.nET] for ProfiNet I/O)
—	091 PdPAdr	PDP [Address]
—	092 dVnbdr	DeviceNet [Baudrate]
—	093 dVnAdr	DeviceNet [Address]
—	094 CCLbdr	CC-link [Baudrate]
—	095 CCLAdr	CC-link [Address]
—	097 IPAddr	ProfiNet/EtherNet-IP [IP address]
—	098 SubMSK	ProfiNet/EtherNet-IP [Subnet Mask]
—	AL	Alibi Memory
—	100 SEq	Sequence number of alibi entry: Content display/printout
—	101 ErASE	Delete alibi memory content yes/no
—	SI	Serial interfaces
—	110 Print	Printer
—	— Port	See Chapter 7.18.1 .
—	111 rEMdSP	Remote display
—	— Port	See Chapter 7.18.1 .
—	112 ModbuS	ModBus RTU
—	— Port	See Chapter 7.18.1 .
—	113 SMA	SMA
—	— Port	See Chapter 7.18.1 .

<ul style="list-style-type: none"> — 114 EW-CoM <ul style="list-style-type: none"> — Port — 115 xBPI <ul style="list-style-type: none"> — Port 	<p>EW-Com See Chapter 7.18.1.</p> <p>xBPI See Chapter 7.18.1.</p>
<ul style="list-style-type: none"> — HS <ul style="list-style-type: none"> — 120 Slot 1 — 121 Slot 2 — 122 Slot 4 — 123 bAt 	<p>Hardware status EMPtY = empty or PR 5510 card type EMPtY = empty or PR 5510 card type EMPtY = empty or PR 1721 card type bAt oK battery status</p>
<ul style="list-style-type: none"> — Pd <ul style="list-style-type: none"> — 124 SEArCH 	<p>Pendeo search Search for Pendeo load cells and set dead load; see Chapter 7.5.6.</p>
<ul style="list-style-type: none"> — CA <ul style="list-style-type: none"> — 150 dModE 	<p>Filling mode, only for EasyFill Select filling mode nE.t = Net filling (B1) or ne.t d.l. = Net decrease (B4)</p>
<ul style="list-style-type: none"> — IM <ul style="list-style-type: none"> — 151 IModE 	<p>Interaction mode, only for EasyFill Select interaction mode See Chapter 8.2.2.</p>
<ul style="list-style-type: none"> — PC <ul style="list-style-type: none"> — 160 nuMPrt — 161 SEqnr — 162 PrtMod — 163...168 LAYou 1...6 	<p>Configure printout, only for EasyFill Number of printouts Enter sequence number. Select printing mode. LAYout = appl. layout or nICELb = NiceLabelExpress Configure line 1...6. nEt = net weight, GroSS = gross weight, MAtnAM = material name, nonE = no printout, FF = formfeed, SEq = sequence number, dAtE = date and time, SEtP = set point, tArE = tare weight, nL = CR/LF (carriage return and line feed)</p>
<ul style="list-style-type: none"> — do <ul style="list-style-type: none"> — 170...172 out 1...3 	<p>Configure digital outputs, only for EasyFill Enter SPM addresses %MXxxx; see Chapter 13.4</p>
<ul style="list-style-type: none"> — dl <ul style="list-style-type: none"> — 174...176 InP 1...3 	<p>Configure digital inputs, only for EasyFill Enter SPM address %MXxxx; see Chapter 13.4</p>
<ul style="list-style-type: none"> — ou <ul style="list-style-type: none"> — 180...191 out 1...12 	<p>Configure digital outputs (PR 5510/12), only for EasyFill Enter SPM address %MXxxx; see Chapter 13.4</p>
<ul style="list-style-type: none"> — In <ul style="list-style-type: none"> — 192...197 out 1...6 	<p>Configure digital inputs (PR 5510/12), only for EasyFill Enter SPM address %MXxxx; see Chapter 13.4</p>

Note:

The meaning of the individual data and parameters and the associated value ranges can be found in the description of operation via Notebook/PC.

7.5.2 Recalibrating the internal weighing point using the front-panel keys

Note:

If linearization is active (see Chapter 7.14.11), `Error 91` appears on the display.

Example:

Max (maximum load) 2000.0 g

Scale interval 0.5 g

Set the dead load with empty scale.

Note:

The device has the following default setting when recalibration is started:

Max 3000 kg

Scale interval 1 kg

Start

1. Switch on the device; see Chapter 7.2. Allow for the warm-up phase for the device to be completed.
2. Open the CAL switch; see Chapter 7.1.3.1.
3. Press .

▷ `SEtUP` appears on the display.

Recalibrating (Cd 000)

4. Press OK.

▷ `cd 000` appears on the display.

The "Cd" calibration menu flashes.

5. Press OK to select the menu item.

▷ `CALib` appears on the display.

6. Press OK.

▷ `nEW` (for new calibration) appears on the display.

Defining the max (maximum load) and weight unit (Cd 001)

7. Press OK.

▷ `cd 001` appears on the display.

The "Cd" calibration menu flashes.

8. Press OK.

▷ MAX.FSD (full scale deflection) appears on the display.

9. Press OK.

▷ ----- .kg appears on the display.

10. Press ← to move the decimal point to the left by one decimal place.

▷ ----- .-kg appears on the display.

11. Press OK.

▷ 00300.0 kg appears on the display (the "3" flashes).

12. Press ↓ (3x) to select the "0" digit.

13. Press ← to select another digit to the left.

14. Press ↑ (2x) to select the "2" digit.

15. Press → (5x) to select the weight unit and change it to "g" with ↑.

Defining the scale interval (Cd002)

16. Press OK.

▷ Cd 002 appears on the display.

17. Press OK.

▷ StEP appears on the display.

18. Press OK.

▷ 1 appears on the display.

19. Press ↑ to change the scale interval to "5" (0.5 g).

Defining the dead load (Cd003)

20. Press OK.

▷ Cd 003 appears on the display.

21. Press OK.

▷ dEAdLo appears on the display.

22. Press OK.

▷ LoAd (dead load with empty scale) appears on the display.

23. Press ↑ to select the "mV/V" entry if necessary.

▷ `MVoIt` appears on the display.

Continue for "dead load with empty scale":

24. Press OK.

▷ `unLoAd` appears on the display.

25. Empty the scale.

26. Press OK.

▷ A weight value for the dead load appears on the display.

27. Press OK.

▷ The dead load is set.

`00000.0 kg` appears on the display.

Defining the span (Cd 004)

28. Press OK.

▷ `Cd 004` appears on the display.

29. Press OK.

▷ `SPAn` appears on the display.

30. Press OK.

▷ `LoAd` (range with weights) appears on the display.

31. Press **↑** to select the "mV/V" entry if necessary.

▷ `MVoIt` appears on the display.

Continue for "range with weights":

32. Press OK.

33. Place the calibration weight on the scale.

▷ A weight value that has not been calibrated yet appears on the display.

34. Press OK.

▷ `WEIGHt` appears on the display.

35. Press OK.

▷ The max. calibration weight of `02000.0 g` appears on the display.

36. Use the cursor keys to set the calibration weight value.

37. Press OK.

▷ `Cd 005` appears on the display.

Saving and exiting

38. Press "Exit."

▷ **SAVE** appears on the display.

39. Press OK.

▷ **YES** appears on the display.

40. Press OK.

▷ **SAVE . . .** appears on the display during the save process.

41. Press "Exit" to exit the Setup menu.

42. If calibration parameters CP 010–CP 026 are not intended to be set or are already set, the CAL switch must be closed now; see Chapter [7.1.3.1](#).

7.5.3 Changing the dead load of the internal weighing point using the front-panel keys

Note:

If linearization is active (see Chapter [7.14.11](#)), **Error 91** appears on the display.

If modifying the mechanics results in the dead load (weight of the empty scale/container) being changed, proceed as described in the following.

Start

1. Switch on the device; see Chapter [7.2](#). Allow for the warm-up phase for the device to be completed.
2. Open the CAL switch; see Chapter [7.1.3.1](#).



3. Press .

▷ **SEtuP** appears on the display.

4. Press OK.

▷ **Cd 000** appears on the display.

The "Cd" calibration menu flashes.

5. Press  to change the parameter number ("000" flashes).
6. Press  to select the parameter number.

Changing the dead load (Cd 003)

7. Press OK.

▷ **dEAdLo** appears on the display.

8. Press OK.

- ▷ `LoAd` (dead load with empty scale) appears on the display.
- 9. Press OK.
- ▷ `unLoAd` appears on the display.
- 10. Empty the scale.
- 11. Press OK.
- ▷ A weight value for the dead load appears on the display.
- 12. Press OK.
- ▷ The dead load is set.
- `00000.0 kg` appears on the display.
- 13. Press OK.
- ▷ `Cd 004` appears on the display.

Saving and exiting

- 14. Press "Exit."
- ▷ `SAVE` appears on the display.
- 15. Press OK.
- ▷ `YES` appears on the display.
- 16. Press OK.
- ▷ `SAVE . . .` appears on the display during the save process.
- 17. Press "Exit" to exit the Setup menu.
- 18. If no other calibration data or parameters are going to be set, the CAL switch must be closed now; see Chapter [7.1.3.1](#).

7.5.4 Displaying the calibration data of the internal WP using the front-panel keys

- 1. Press .
- ▷ `SEtUP` appears on the display.
- 2. Press OK.
- ▷ `Cd 000` appears on the display.
- The "Cd" calibration menu flashes.
- 3. Press OK to select the menu item.
- ▷ `CALib` appears on the display.

When the CAL switch is closed, **CAL.CLS** appears on the display.

4. Press OK.

▷ **nEW** appears on the display.

5. Press **↑**.

▷ **VIEW** appears on the display.

6. Press OK.

▷ **CAL.oPn** (CAL switch open) appears on the display.

7. Press OK.

▷ **MAX.FSd** (full scale deflection) appears on the display.

8. Press OK.

▷ The set maximum load appears on the display.

9. Press OK.

10. Press OK.

▷ **Cd 002** appears on the display.

11. Press OK.

▷ **StEP** appears on the display.

12. Press OK.

▷ The set scale interval appears on the display.

13. Press OK.

▷ **Cd 003** appears on the display.

14. Press OK.

▷ **dEAdLo** appears on the display.

15. Press OK.

▷ The weight value for the dead load appears on the display.

16. Press OK.

▷ **dEAdLo** appears on the display.

17. Press OK.

▷ The mV/V value for the dead load appears on the display.

18. Press OK.

- ▷ Cd 004 appears on the display.
- 19. Press OK.
- ▷ SPAn appears on the display.
- 20. Press OK.
- ▷ The mV/V value for the maximum load appears on the display.
- 21. Press OK.
- ▷ Cd 005 appears on the display.
- 22. Press OK.
- ▷ O-rnG appears on the display.
- 23. Press OK.
- ▷ The used zero-setting range appears on the display.
- 24. Press OK.
- ▷ Cd 006 appears on the display.
- 25. Press OK.
- ▷ uVoLt.d appears on the display.
- 26. Press OK.
- ▷ The measurement signal appears on the display in $\mu\text{V}/\text{d}$.
- 27. Other parameters, if any, can be displayed in the same way.

7.5.5 Reading out calibration data for WP dead load and max using the front-panel keys

All settings for the device should normally be written down or printed out during commissioning.

If an error occurs and a device must be replaced and no new calibration is carried out, the values for the dead load and maximum load must be available in mV/V.

Procedure

1. Press .
 - ▷ SEtUP appears on the display.
2. Press OK.
 - ▷ Cd 000 appears on the display.

The "Cd" calibration menu flashes.
3. Press \rightarrow to change the parameter number ("000" flashes).
4. Press \uparrow multiple times to select parameter number "003."
5. Press OK.

- ▷ `dEAdLo` appears on the display.
- 6. Press OK.
 - ▷ `LoAd` appears on the display.
- 7. Press **↑** to select "MvoLt."
- 8. Press OK.
 - ▷ The mV/V value for the dead load appears on the display.
- 9. Note the displayed value.
- 10. Press OK.
 - ▷ `Cd 004` appears on the display.
- 11. Press OK.
 - ▷ `SPAn` appears on the display.
- 12. Press OK.
 - ▷ `MvoLt` appears on the display.
- 13. Press OK.
 - ▷ The mV/V value for the maximum load appears on the display.
- 14. Note the displayed value.
- 15. Press "Exit" to exit the Setup menu.

7.5.6 Search for Pendeo load cells and set dead load using the front-panel keys

In this menu, a search for connected load cells is conducted and the dead load is set. The load cell type (Pendeo Truck or Pendeo Process) is automatically detected.

Note:

Assigning the Pendeo load cells is only possible with a notebook/PC; see Chapter [7.16.6](#). In the process, the dead load is deleted and a recalibration must be carried out.

Procedure

1. Press .
 - ▷ `SEtuP` appears on the display.
2. Press OK.
 - ▷ `Cd 000` appears on the display.

The "Cd" calibration menu flashes.
3. Press **↓** (1x) to select the "Pd 124" menu.
4. Press OK.



- ▷ `SEArCH` appears on the display.
- 5. Press OK.
- ▷ `YES` appears on the display.
- 6. Press OK.
- ▷ A search for connected load cells is conducted and the dead load is set immediately thereafter.
- 7. Press "Exit" to exit the Setup menu.

7.5.7 Creating a PIN code using the front-panel keys

The Setup menu can be protected from unauthorized access with a PIN code defined by the user.

Setting up a PIN code

1. Press .
 - ▷ `SEtuP` appears on the display.
2. Press OK.
 - ▷ `Cd 000` appears on the display.

The "Cd" calibration menu flashes.
3. Press  multiple times to select "oP."
 - ▷ `oP 060` appears on the display.
4. Press  to change the parameter number ("000" flashes).
5. Press  to select the parameter number.
 - ▷ `oP 061` appears on the display.
6. Press OK.
 - ▷ `PIn` appears on the display.
7. Press OK.
 - ▷ `000000` (= no prompt) appears on the display.
8. Press the cursor keys to enter a PIN code.
9. Press OK to save the PIN code.

Entering the PIN code

10. Press .
 - ▷ `SEtuP` appears on the display.

11. Press OK.
 - ▷ **PIn** appears on the display.
12. Press OK.
 - ▷ **000000** appears on the display.
13. Press the cursor keys to enter the PIN code.
14. Press OK.
 - ▷ If a wrong PIN code has been entered, **PInWro** appears on the display.
15. Press OK.
 - ▷ **000000** appears on the display.
16. Press the cursor keys to enter the correct PIN code.
 - ▷ If the right PIN code has been entered, **Cd 000** appears on the display.

The "Cd" calibration menu flashes.

Entering the SUPER PIN code

If the PIN code is lost, the Setup menu can be unlocked with SUPER PIN code "212223."

17. Press .
 - ▷ **SEtuP** appears on the display.
18. Press OK.
 - ▷ **PIn** appears on the display.
19. Press OK.
 - ▷ **000000** appears on the display.
20. Press the cursor keys to enter SUPER PIN code "212223."
21. Press OK.

7.5.8 Deleting the PIN code using the front-panel keys

1. Press .
 - ▷ **SEtuP** appears on the display.
2. Press OK.

- ▷ `PIIn` appears on the display.
- 3. Press OK.
- ▷ `000000` appears on the display.
- 4. Press the cursor keys to enter the PIN code.
- 5. Press OK to save the PIN code.
- 6. Press OK.
- ▷ `Cd 000` appears on the display.
- The "Cd" calibration menu flashes.
- 7. Press **↑** multiple times to select "oP."
- ▷ `oP 060` appears on the display.
- 8. Press **→** to change the parameter number ("000" flashes).
- 9. Press **↑** to select the parameter number.
- ▷ `oP 061` appears on the display.
- 10. Press OK.
- ▷ `PIIn` appears on the display.
- 11. Press OK.
- ▷ The PIN code appears on the display.
- 12. Press the cursor keys to enter PIN code "000000" (=no prompt).
- 13. Press OK to save the entry.

7.5.9 Entering fieldbus parameters using the front-panel keys

Example:

Fieldbus card PR 1721/36 ProfiNet I/O

1. Press .
 - ▷ `SEtuP` appears on the display.
2. Press OK.
 - ▷ `Cd 000` appears on the display.
 - The "Cd" calibration menu flashes.
3. Press **↑** multiple times to select "FP 090."
4. Press OK.
 - ▷ `Prot` (protocol) appears on the display.

5. Press OK.
 - ▷ `Pro.nEt` appears on the display.
6. Press OK.
 - ▷ `FP 097` appears on the display.
7. Press OK.
 - ▷ `IP.Addr` appears on the display.
8. Press OK.
 - ▷ The more significant part of the address* `000.000.` appears on the display.
9. Press the cursor keys to select and set the desired numbers.
10. Once the last number is selected and set, press → to set the less significant part of the address*.
 - ▷ `000.000.` appears on the display.
11. Press the cursor keys to select the desired numbers.
12. Press OK.
 - ▷ `FP 098` appears on the display.
13. Press OK.
 - ▷ `SubnEt` (subnet mask) appears on the display.
14. Press OK.
 - ▷ The more significant part of the mask* `255.255.` appears on the display.
15. Press the cursor keys to select and set the desired numbers.
16. Once the last number is selected and set, press → to set the less significant part of the mask*.
 - ▷ `255.000.` appears on the display.
17. Press the cursor keys to select the desired numbers.
18. Press OK.
 - ▷ `SAVE` appears on the display.
19. Press OK.
 - ▷ `YES` appears on the display.
20. Press OK.

▷ `SAVE . . .` appears on the display during the save process.

21. Press "Exit" to exit the Setup menu.

*

An error message appears if the digit group for the IP address/mask is not within 0–255, or is invalid.

7.5.10 Entering the network address using the front-panel keys

Note:

A new address may be assigned by the server in the event of a restart.

1. Press .

▷ `SEtuP` appears on the display.

2. Press OK.

▷ `Cd 000` appears on the display.

The "Cd" calibration menu flashes.

3. Press  multiple times to select "nP 080."

4. Press OK.

▷ `dHCP` (DHCP) appears on the display.

5. Press OK.

▷ `on` appears on the display.

DHCP is activated. The network address is assigned automatically.

If DHCP is not activated ("oFF"), the addresses must be entered manually.

6. Press OK.

▷ `nP 081` appears on the display.

7. Press OK.

▷ `IP.Addr` appears on the display.

8. Press OK.

▷ The more significant part of the address* `172.024.` (example) appears on the display.

9. If DHCP "oFF" is selected: Press the cursor keys to select and set the desired numbers.

10. Once the last number is selected and set, press  to set the less significant part of the address*.



- ▷ 020.128. (example) appears on the display.
11. If DHCP "off" is selected: Press the cursor keys to select and set the desired numbers.
12. Press OK.
- ▷ nP 082 appears on the display.
13. Press OK.
- ▷ SubnEt (subnet mask) appears on the display.
14. Press OK.
- ▷ The more significant part of the mask* 255.255. appears on the display.
15. Press the cursor keys to select and set the desired numbers.
16. Once the last number is selected and set, press → to set the less significant part of the mask*.
- ▷ 255.255. appears on the display.
17. Press the cursor keys to select and set the desired numbers.
18. Press OK.
- ▷ nP 083 appears on the display.
19. Press OK.
- ▷ GtAddr (gateway) appears on the display.
20. Press OK.
- ▷ The more significant part of the address* 000.000. appears on the display.
21. Press the cursor keys to select and set the desired numbers.
22. Once the last number is selected and set, press → to set the less significant part of the mask*.
- ▷ 000.000. appears on the display.
23. Press the cursor keys to select and set the desired numbers.
24. Press OK.
- ▷ nP 084 appears on the display.
25. Press OK.
- ▷ CLIEnt (VNC client) appears on the display.
26. Press OK.

- ▷ The more significant part of the address* 255.255. (example) appears on the display.
27. Press the cursor keys to select and set the desired numbers.
 28. Once the last number is selected and set, press → to set the less significant part of the mask*.
 - ▷ 255.255. (example) appears on the display.
 29. Press the cursor keys to select and set the desired numbers.
 30. Press OK.
 - ▷ nP 085 appears on the display.
 31. Press OK.
 - ▷ EtAddr (hardware address/MAC ID) appears on the display.
 32. Press OK.
 - ▷ The more significant part of the address* 00.90.6C. (example) appears on the display.
 33. Press → to display the less significant part of the mask*.
 - ▷ 70.49.45. (example) appears on the display.
 34. Press OK.
 - ▷ SAVE appears on the display.
 35. Press OK.
 - ▷ YES appears on the display.
 36. Press OK.
 - ▷ SAVE ... appears on the display during the save process.
 37. Press "Exit" to exit the Setup menu.

Note:

* Err 31 appears on the display if the digit group for the IP address/mask is not within 0–255, or is invalid.

7.5.11 Displaying the network address using the front-panel keys

1. Press .
 - ▷ **SEtuP** appears on the display.
2. Press OK.
 - ▷ **Cd 000** appears on the display.
The "Cd" calibration menu flashes.
3. Press  multiple times to select "nP 080."
4. Press OK.
 - ▷ **dHCP** (DHCP) appears on the display.
5. Press OK.
 - ▷ **on** appears on the display.
6. Press OK.
 - ▷ **nP 081** appears on the display.
7. Press OK.
 - ▷ **IP.Addr** appears on the display.
8. Press OK.
 - ▷ The more significant part of the address **172.024.** (example) appears on the display.
9. Press  to display the less significant part of the address.
 - ▷ **020.128.** (example) appears on the display.
10. Press "Exit" multiple times to exit the Setup menu.

7.6 Displaying/deleting alibi entries using the front-panel keys

The alibi memory of the device can be displayed and/or deleted directly using the front-panel keys.

7.6.1 Displaying/deleting alibi entries

1. Press .
 - ▷ **SEtuP** appears on the display.
2. Press OK.
 - ▷ **Cd 000** appears on the display.

The "Cd" calibration menu flashes.

3. Press **↓** multiple times to select "AL 100."
4. Press OK.
 - ▷ **SEQ** appears on the display.
5. Press OK.
 - ▷ The sequence number of the last alibi entry appears on the display (right digit flashes).
6. Press the cursor keys to select the desired sequence number.
7. Press OK.
 - ▷ **YEAr** appears on the display.
8. Press OK.
 - ▷ The year of the alibi entry appears on the display.
9. Press OK.
 - ▷ **dAtE** appears on the display.
10. Press OK.
 - ▷ The date of the alibi entry appears on the display.
11. Press OK.
 - ▷ **tIME** appears on the display.
12. Press OK.
 - ▷ The time of the alibi entry appears on the display.
13. Press OK.
 - ▷ **GroSS** appears on the display.
14. Press OK.
 - ▷ The gross weight of the alibi entry appears on the display.
15. Press OK.
 - ▷ **PrInt** appears on the display.
16. Press OK.
 - ▷ **no** appears on the display.
17. Press **↑** to select "YES."
18. Press OK.
 - ▷ The alibi entry is printed out.
19. Press "Exit" to exit the Setup menu.

7.6.2 Deleting alibi entries

1. Press .
 - ▷ **SEtUP** appears on the display.
2. Press OK.
 - ▷ **Cd 000** appears on the display.

The "Cd" calibration menu flashes.
3. Press **↓** multiple times to select "AL 100."
4. Press **→** to change the parameter number ("100" flashes).
5. Press **↑** to select parameter number "101."
6. Press OK.
 - ▷ **ErASE** appears on the display.
7. Press OK.
 - ▷ **no** appears on the display.
8. Press **↑** to select "YES."
9. Press OK.
 - ▷ All alibi entries are deleted.
10. Press "Exit" to exit the Setup menu.

7.7 Finding and connecting a device with a notebook/PC

If the device is connected to a notebook/PC via a point-to-point connection, an IP address is negotiated via function "AutoIP". This can take up to 2 minutes!

NOTICE

When the IT/DHCP network cable is temporarily connected between the notebook/PC and a device, the DHCP server is lost and the notebook/PC returns to the auto-IP address within approx. two minutes!

- ▶ Reason: The DHCP server/client relationship is checked cyclically at 2...3-minute intervals.

1. On the notebook/PC, set the LAN local and Internet Protocol properties to "Obtain an IP address automatically" depending on the operating system.
2. On the device, under  - [Network parameters] activate the "Use DHCP" parameter (factory/default settings).
 - ▷ The DHCP devices find each other because they fall into an "auto-IP address" in the range 169.254.0.1...169.254.255.254 with the associated auto-subnet mask 255.255.0.0 after a cyclical automatic DHCP server search run due to time overflow (2...3 minutes).

Example:

If the search time is exceeded (because there is "no server found"), the PR 5410 is assigned to an IP address automatically (e.g. 169.254.0.123). The same applies to the notebook or PC (e.g. 169.254.0.54).

These IP addresses are different on both sides:

- equal regarding the first 2 octets of the IP address (e.g. network ID 169.254.)
- different in the last 2 octets of the IP address (e.g. host ID 0.123.)

7.8 Finding and connecting the device automatically in the network

If the DHCP server is active in the network, the connected device (default setting under  - [Network parameters]: "Use DHCP" is activated.) is automatically assigned an IP address.

On the notebook/PC, the host names of the connected devices in the network are listed under [Network].

Double-click the host name to open the device page in the web browser. The IP address is displayed on the bottom right.

Note:

If the web browser supports the Java application, the device can be operated via [remote configuration (VNC).]

If the web browser does **not** support the Java application, the menu items will be inaccessible (grayed out).

7.9 Searching the device in the network with "IndicatorBrowser"

The IP address can be found out using the "IndicatorBrowser" application (supplied on CD-ROM) and via the "host name" of the device.

The "host name" is composed of the device name and the last 3 bytes of the MAC ID. A label with the complete MAC ID is located on the outside of the device.

MAC: 00:90:6C:6B:6A:5E	
IP: _____	

Host name: PR5410-6B6A5E



For this, the program must be installed and started on a notebook/PC.

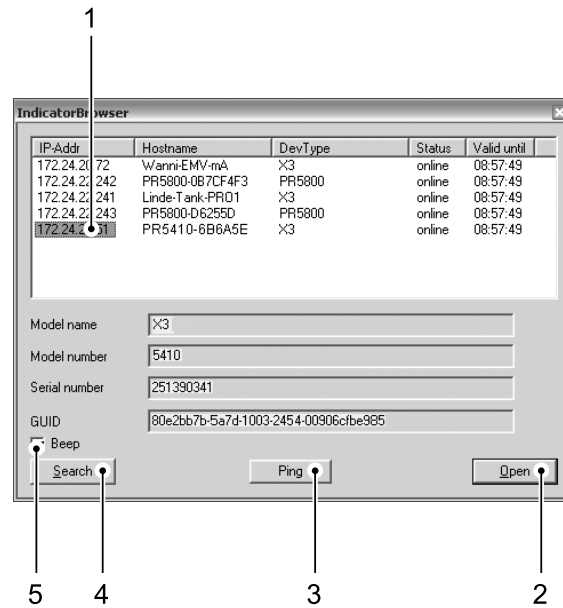

No.	Description
1	The program searches within the current network ID, e.g. 169.254. and 172.24., on all available network adapters in the PC (several possible/recommended, e.g. LAN global/LAN local) Result: List of all connected devices with status: search??? – online - byebye – lost???
2	Click the button to open the "standard" Internet Browser, e.g. Microsoft Internet Explorer, directly with the marked IP-address.
3	Click the button to localize the associated device. Short-term visual feedback from the device: Regular running light in LED 1, 2, 3.
4	Click the button to re-start the network search run. Waiting 2...3 minutes is essential!
5	Acoustic signal for each device that was detected as "online."

Note:

If the browser window remains empty after the minimum wait time, or if the expected device is not listed, the network ID of the local notebook/PC must be checked and changed, if necessary.

Only certain Minebea Intec devices are supported by the "indicator browser"!

7.10 Resetting the network address

This means

- "DHCP" is activated.
- "Hostname" is initialized to, e.g. PR 5410-6B6A5E (type MAC-ID).

Example of MAC ID: 00-90-6C-6B-6A-5E

This ensures that a valid address for identification of the device in the network can be assigned to the device from a server, see also Chapter [7.18.6](#).

Note:

The last 3 bytes of the MAC ID are displayed. A label with the complete MAC ID is located on the outside of the device.

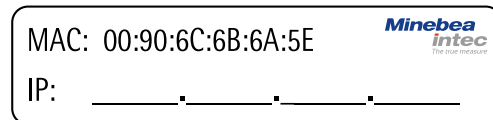

If the device is connected to an IT network (company network) with an DHCP server and was activated under  - [Network parameter] of the "Use DHCP" parameter (default/factory setting), it does not require further actions except for a 2...3-minute waiting time. Subsequently, a network connection is established automatically (device <-> workstation/PC).

7.11 Operation using VNC

VNC (on the enclosed CD-ROM) stands for "virtual network computing" and is a program for remote operation of computers.

The program distinguishes between the VNC server and VNC client (viewer). The server program is part of the device software, the client program (viewer) must be run on the notebook/PC in order to operate the device.

Note:

If the colors appear distorted, a better color format must be selected in the VNC viewer.

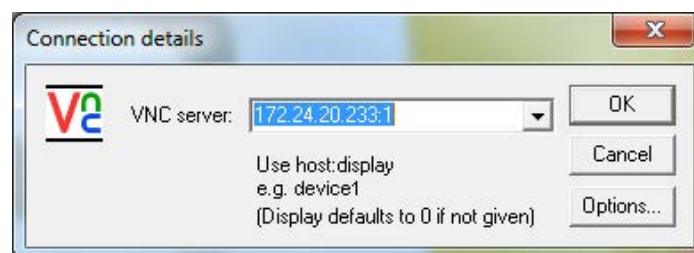

For direct operation using the VNC program, the IP address (extended by :1) must be specified when you run the program, e.g., 172.24.20.233:1.

Note:

In the device, the VNC access to certain notebooks/PCs in the network can be limited, see Chapter [7.18.6](#).

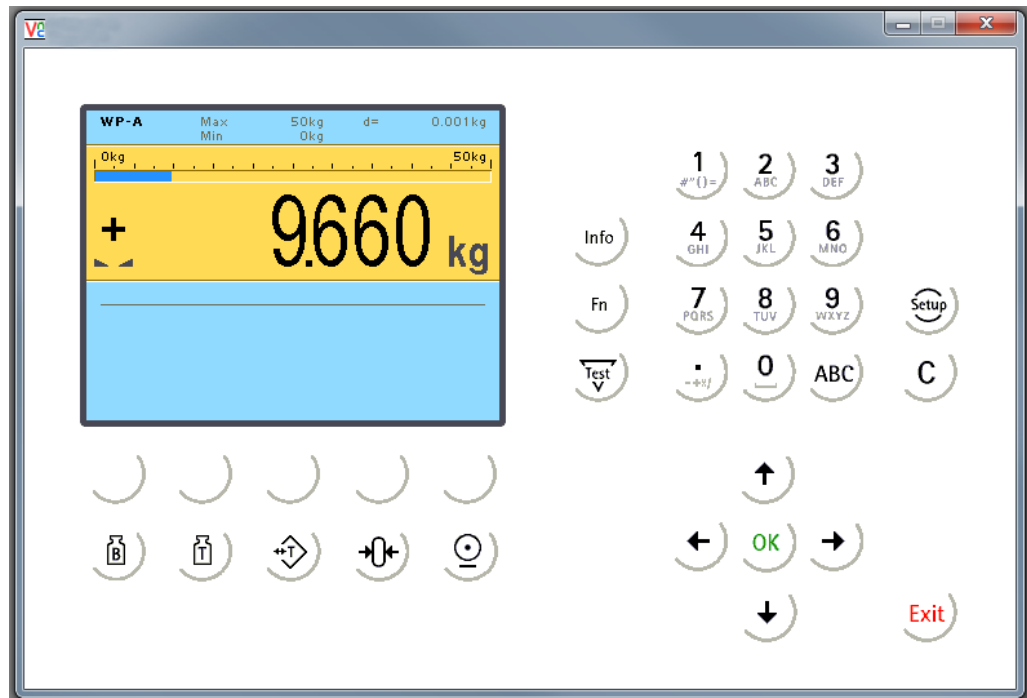

NOTICE

If the VNC viewer is terminated on the setup level (e.g. by closing the window or the back function in the web browser), the device reboots and the web menu is not accessible for several seconds.

- ▶ Before terminating the VNC viewer keep pressing the **Exit** key to quit the setup level.

7.12 Operation via a web browser

Instead of the VNC viewer, the web browser can also be used directly. The disadvantage is that an additional "Java" installation is required.

Note:

If the web browser supports the Java application, the device can be operated via [remote configuration (VNC).]

If the web browser does **not** support the Java application, the menu items will be inaccessible (grayed out).

In addition to VNC, this includes:

- easy operation for printing out the configuration
- easy operation for displaying and saving protocols
- easy operation for saving and loading configuration and calibration data

Example: 

Enter the IP address in the Internet browser and confirm.

The web menu is displayed.

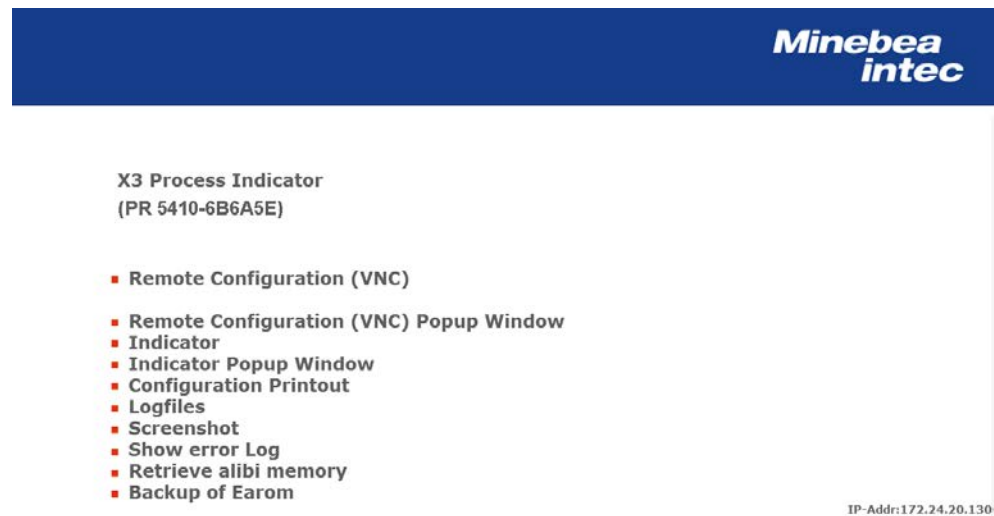

For description of the web menu see Chapter [9.2.1](#).

NOTICE

If the VNC viewer is closed on the setup level, the device reboots and the web menu is not accessible for several seconds.

- ▶ If the web menu and the device view are required, the [Remote Configuration (VNC) Pop-up Window] menu item must be selected in order for 2 windows to be opened with the VNC viewer always remaining open, even if individual menu items are selected in the web menu.

7.13 System setup

7.13.1 Serial ports parameter

<ul style="list-style-type: none"> — Printer <ul style="list-style-type: none"> — Param — Config — Remote display <ul style="list-style-type: none"> — Param — ModBus RTU <ul style="list-style-type: none"> — Param — SMA <ul style="list-style-type: none"> — Param — EW-Com <ul style="list-style-type: none"> — Param 	<p>Printer Selection: <none>, built-in RS232 Selection: Assigned to, protocol, Baudrate, Bits, Parity, Stopbits, Output mode See Menu [Printing parameter].</p> <p>Remote display Selection: <none>, built-in RS-232 Selection: Assigned to, Baudrate, Bits, Parity, Stopbits, Mode</p> <p>ModBus RTU Selection: <none>, built-in RS-232 Selection: Assigned to, Baudrate, Bits, Parity, Stop bits, Slave-ID</p> <p>SMA Selection: <none>, built-in RS-232 Selection: Assigned to, Baudrate, Bits, Parity, Stopbits</p> <p>EW-Com Selection: <none>, built-in RS-232 Selection: Assigned to, Baudrate, Bits, Parity, Stopbits, Slave-ID</p>
---	---

<ul style="list-style-type: none"> └─ xBPI-Port <ul style="list-style-type: none"> └─ Param 	<p>Selection: <none>, built-in RS-232</p> <p>Selection: Assigned to, Baudrate, Bits, Parity, Stopbits</p>
--	---

7.13.2 Date & time

<ul style="list-style-type: none"> └─ Date 	<p>Date</p> <p>Input: yyyy, mm, dd</p>
<ul style="list-style-type: none"> └─ Time 	<p>Time</p> <p>Input: hh, mm, ss</p>

7.13.3 Operating parameters

<ul style="list-style-type: none"> └─ Application 	<p>Selection: Standard, EasyFill</p>
<ul style="list-style-type: none"> └─ Address 	<p>Device address, e.g. for printing</p> <p>Input: A...Z</p>
<ul style="list-style-type: none"> └─ PIN 	<p>Entry code with which to protect the system control from unauthorized use.</p> <p>Input: 6 numerical characters</p>
<ul style="list-style-type: none"> └─ Use Alibi memory 	<p>Select which values should be written in the Alibi memory.</p> <p>Selection: <none>; Gross; Net; Gross, Net, Tare; Gross, Net; Gross, Tare</p>
<ul style="list-style-type: none"> └─ Sequence number 	<p>Automatic counter for individual print jobs</p>
<ul style="list-style-type: none"> └─ SetTareKey 	<p>Tare key</p> <p>Selection: Tare&reset tare, tare&tare again, disabled</p>
<ul style="list-style-type: none"> └─ SetZeroKey 	<p>Set zero key</p> <p>Select: only when not tared, reset tare on zeroset, disabled.</p>
<ul style="list-style-type: none"> └─ N-G-T-Key 	<p>Net - gross - tare - front key turn on/off</p> <p>Select: disabled, enabled.</p>
<ul style="list-style-type: none"> └─ PrintKey 	<p>Print front key turn on/off</p> <p>Select: disabled, enabled.</p>
<ul style="list-style-type: none"> └─ TestKey 	<p>Test front key turn off/on</p> <p>Select: disabled, enabled.</p>

7.13.4 Printing parameter

Note:

This menu item is only available if under -[Operating parameter]- [Application] "Standard" has been selected.

<ul style="list-style-type: none"> └─ Print mode 	<p>Print mode</p> <p>Selection: <Print selected items>, via Nice Lable (configure printout with Nice Label Express (NLE).)</p>
<ul style="list-style-type: none"> └─ 1...6. Item 	<p>Print layout for line 1...6; see Chapter 7.18.4.</p>

7.13.5 Fieldbus parameter

- └─ Fieldbus protocol

7.13.6 Network parameter

- └─ HW address

MAC-ID, display: e.g.: 00:90:6C:31:1F:55

- └─ Hostname

Unique device name, input: 2...24 alphanumeric characters

- └─ Use DHCP

Check the box to activate DHCP.

- └─ IP address

IP address, display: network address assigned by the server

- └─ Subnet mask

Subnet mask, display: Mask for valid IP address range

- └─ Default gateway

Standard gateway, display: IP number for gateway

- └─ Remote access

Remote access to VNC client

- └─ VNC client

Access restriction, Input: authorized client for instrument operation

7.13.7 Weighing points

- └─ Weighing point A

Selection: Internal A, xBPI-scale, Pendeo Load Cells, Connexx Load Cells

- └─ Calib

Calibration, selected "Internal A:" New, Modify, Param, see Chapter [7.13.7.1](#).

- └─ Setup

Setup, "xBPI-Scale" selected: Calibration, Configuration, Select, Show device info, see Chapter [7.13.7.2](#).

- └─ Config

Configuration, "xBPI-Scale" selected: Type, W&M, Tare timeout, Serial number, SBN Address, see Chapter [7.13.7.2](#).

- └─ Param

Configuration, "xBPI-Scale" selected: Assigned to, Baudrate, Bits, Parity, Stopbits, see Chapter [7.13.7.2](#)

- └─ Assign

Assign, "Pendeo Load Cells" selected: Search, View, Calib, LC name, Service, see Chapter [7.13.7.3/7.13.7.4](#).

7.13.7.1 "Internal A" weighing point

- └─ Calib

Calibration of the weighing electronics

- └─ New

Query window for new calibration: Reset Span and dead load

- └─ Max

Contin, Cancel

- └─ Scale interval

Input of the maximum load:

- └─ Dead load at

0.00001...<3000>...999999 <kg>, t, lb, oz, g, mg

- └─ Max at

Input of the scale interval: <1>, 2, 5, 10, 20, 50

- └─ Max at

<0.000000 mV/V> or [by load]

- └─ Max at

[by load]: 0.00001...999999 <kg>, t, lb, oz, g, mg

- └─ Max at

<1.000000 mV/V> or [by load]

- └─ Max at

<1.000000 mV/V> or [by load]

		[by load]: 0.00001...999999 <kg>, t, lb, oz, g, mg
	— Calibrated at	Display only
	— Sensitivity ($\mu\text{V}/\text{d}$)	Display only
	— Test	Determine test value
	— Exit calibration	Save or discard changes due to new calibration.
	— Modify	May be used only for minor changes (e.g. changing the dead load, adapting mV/V values for dead load and/or Max). Otherwise, always use [New]!
	— Param	Parameter settings
	— Measurtime	Input of the measuring period: 5, 10, 20, 40, 80, 160, <320>, 640, 960, 1280, 1600 ms
	— Digital filter	Selection of the digital filters: <off>, Bessel, aperiod., Butterw., Tcheby.
	— External supply	Without function, see Chapter 4.6.7.
	— Fcut	Input of cut off frequency, only unless filter not "off", 0.1–80.0 Hz
	— Test mode	Selection for display of the deviation from the test value: <Absolute>, relative
	— W&M	Selection legal-for-trade mode: <none>, OIML (impossible when [Range mode] "Multi-interval" has been selected or Max has more than 3 decimals), NSC, NTEP
	— Standstill time	Input of the standstill period: 0.01 s...<0.50 s>...2.0 s (The range depends on the measuring time.)
	— Standstill range	Input of the standstill range: 0.00 d...<1.00 d>...10.00 d
	— Tare timeout	Input of timeout when there is no standstill: 0.1 s...<2.5 s>...25 s
	— Zeroset range	\pm Range of zero point when there is no standstill. Input: 0.00 d...<50.00 d>...10000.00 d
	— Zerotrack indic. range	Input of the zerotrack indication range: 0.00 d...<0.25 d>...10000.00 d
	— Zerotrack step	Input of the zerotrack step: 0.00 d...<0.25 d>...10.00 d
	— Zerotrack time	Input of the zerotrack time: <0.0 s>...25 s
	— Overload	Input of the weighing range above the maximum load (Max) without error message: 0...999999 d
	— Minimum weight	Input of the minimum load: 0 d...<50 d>...999999 d
	— Range mode	Range selection: <Single range>, Multiple range, Multi-interval See also Chapters 7.14.15.2 and 7.14.15.3.
	— Range limit 1	Input of the limit 1: In weight, unit same as Max, transition from small to medium scale interval Only for [Multiple range] or [Multi-interval]!
	— Range limit 2	Input of the limit 2: In weight, unit same as Max, transition from small to medium scale interval

View	Only for [Multiple range] or [Multi-interval]! (when CAL-switch is closed)
Max	Display only
Scale interval	Display only
Dead load at	Display only
Max at	Display only
Calibrated at	Display only
Sensitivity (µV/d)	Display only
Param	Items as for [Param] (display only)

7.13.7.2 "xBPI scale" weighing point

Setup	Setup of the xBPI scale
Calibration	Calibration of xBPI scale
Dead load	Dead load/preload
Set	Set dead load/preload: Accept, ResError, Abort
Delete	Clear dead load/preload: Accept, ResError, Abort
Span	
Calibrate with user weight	Calibrate with user-defined weight.
Calibrate with auto weight	Calibrate with automatic weight detection.
Adjust with default weight	Calibrate with standard weight.
Adjust with internal weight	Calibrate with internal weight.
Linearity	Setting linearity.
Default	Resetting the Device to the Factory Settings: Accept, ResError, Abort
User	User defined settings: Accept, ResError, Abort
Configuration	Configuration of the scale
Weighing parameters	Weighing parameters
Ambient conditions	Select environmental conditions: Very stable, stable, unstable, very unstable
Application filter	Select application filter: Final readout, Filling mode, Low filtering, w/o filtering
Standstill range	Select standstill range: 0.25 igit, 0.5 digit, 1 digit, 2 digit, 4 digit, 8 digit
Stability symb. delay	Select Stability delay: no delay, short delay, average delay, long delay
Tare parameter	Select taring: at any time, not until stable
Auto zero function	Auto-Zero: auto zero on, auto zero off
Adjustment function	Adj. sequence: ext.adj.w.fact.wt., ext.adj.w.user.wt., ext.adj.w.pres.wt., internal adjust, ext.lin.w.fact.wt., ext.lin.w.user.wt., confirm preload, delete preload, adjust disabled
Confirming adjust.	Confirm calibration: manual, automatically
Zero range	Zero point range: 1% of max load = 1%/Max. load, 2% of max load = 2%/Max. load, 5% of max load = 5%/Max. load, 10% of max load = 10%/Max. Load

—	Power-On zero range	Initial zero point range: 2% of max load = 2%/Max. load, 5% of max load = 5%/Max. load, 10% of max load = 10%/Max. load, 20% of max load = 20%/Max. Load
—	Power-On tare/zero	Tare/zero at power on: active, inactive, only for zeroing
—	Measure rate	Measurement speed: normal output, fast output
—	Calibration check	Calibration check: calibration prompt, off
—	External adjustment	External adjustment: accessible, blocked
—	Application settings	Setting up application
—	Application Tare	Application Tare: accessible, blocked
—	Number of units	Number of weight units: 1 weight unit, 2 weight units, 3 weight units
—	Weight unit 1...3	Chose weight unit 1...3: Gramm [g], Kilogram [kg], Carat [ct], Pound [lb], ounce [oz], Troy ounce [ozt], Tael Hongkong [tlh], Tael Singapore [tls], Tael Taiwan [tlt], Grain [GN], Pennyweight [dwt], Milligram [mg], Parts/pound [/lb], Tael china [tlc], Momme [mom], Karat [k], Tola [tol], Baht [bat], Mesghal [m], Ton [t]
—	Display accuracy 1...3	Chose display accuracy 13: all digits, reduced when moved, one level lower, two level lower, three level lower, 1%, 0.5%, 0.2%, 0.1%, 0.05%, 0.02%, 0.01%, Multi-interval, increased by 10
—	Interface settings	Configure the interfaces
—	Communication type	Communication type: SBI protocol, xBPI protocol
—	Baudrate for SBI	150 baud, 300 baud, 600 baud, 1200 baud, 2400 baud, 4800 baud, 9600 baud, 19200 baud
—	Parity for SBI	Select parity: Mark, Space, Odd, Even
—	Stop bits	Selection: 1 stop bit, 2 stop bits
—	Handshake	Selection: Software handshake, CTS with 2 chr.pau = CTS with 2 characters, CTS with 1 chr.pau = CTS with 1 character
—	Data output interval	Select Data output interval: with each display, after 2 updates, after 5 updates, after 10 updates, after 20 updates, after 50 updates, after 100 updates
—	Parameter change	parameter change: can be changed, cannot be changed
—	Select specification group	
—	Specif. group 1...6	Select specification group of the scale (see operating manual of the relevant scale)
—	Show device info	
—	Set user	Enter the user name of the connected device
—	Set SBN	The xBPI address of the interface has to be <0 >, because there is no bus operation.

<ul style="list-style-type: none"> — Config <ul style="list-style-type: none"> — Type — W&M — Tare timeout — Serial number — SBN Address — Param <ul style="list-style-type: none"> — Assigned to — Baudrate — Bits — Parity — Stop bits 	<p>Configuration of the xBPI scale</p> <p>xBPI-Scale Selection legal-for-trade mode: <none>, OIML, NSC, NTEP</p> <p>Timeout due to instability: 0.1 s...<2.0 s>...25 s <0>, if >0 the serial number will be checked (at legal-for trade scale)</p> <p><0> no bus operation.</p> <p>parameter settings of the xBPI scale</p> <p>Assigned to: xBPI-Port 1</p> <p>Select transmission speed: <9600>, 19200</p> <p>8</p> <p>odd (odd parity)</p> <p>Selection: <1>, 2</p>
--	---

7.13.7.3 "Pendeo® Truck/Process" weighing point

<ul style="list-style-type: none"> — Assign <ul style="list-style-type: none"> — Search <ul style="list-style-type: none"> — View <ul style="list-style-type: none"> — Info — Assign — Calib <ul style="list-style-type: none"> — New <ul style="list-style-type: none"> — Local gravity — Number of platforms — Number of vessel feet — Max — Scale interval — Dead load — CAL weight — Corner correction 	<p>Assignment of the Pendeo scale</p> <p>Type, number of load cells, serial number of each load cell and weighing point serial number (when it was already calculated) are displayed (when "Search" was executed).</p> <p>Search connected load cells.</p> <p>Search for a new network and reset the load cell data to the factory settings.</p> <p>Serial number and current weigh of connected load cells are displayed.</p> <p>The data for the selected Loading cell are displayed.</p> <p>load cells (serial number) are assigned to the installation site.</p> <p>Serial number and current weigh of connected load cells are displayed.</p> <p>Query window for new calibration: Corner correction will be reset Yes, No</p> <p>Enter the on-site gravitational acceleration (Standard: Hamburg 9.81379 m/s²)</p> <p>Only for Pendeo Truck: Only shown if the number of load cells is equal to 8.</p> <p>Only for Pendeo process: Enter the number.</p> <p>Enter maximum load: 0.000010...<3000>...9999998 <kg>, t, lb, g, mg, oz</p> <p>Enter verification interval (1 d): <1>, 2, 5, 10, 20, 50 displayed according to the decimal places at Max and the weight unit.</p> <p>dead load: Weight of the empty scale</p> <p>Enter CAL weight: 0.000010...9999998 <kg>, t, lb, g, mg, oz</p> <p>Platform 1, platform 2 (only shown if the number of load cells is = 8). O.k., when realized.</p>
---	---

	Modify	May be used only for minor changes (e.g. changing the dead load). Otherwise, always use [New]!
	Param	Parameter settings
	Ambient conditions	Select environmental conditions: Very stable, stable, unstable, very unstable
	W&M	Selection legal-for-trade mode: <none>, OIML, NSC, NTEP
	Unbal. Check deviat.	Unbalanced check deviation: The plausibility check is activated when the average deviation is >0%. Input: 0...100 %
	Standstill time	Input of the standstill period: 0.01 s...<0.50 s>...2.0 s (The range depends on the measuring time.)
	Standstill range	Input of the standstill range: 0.00 d...<1.00 d>...10.00 d (The range depends on the measuring time.)
	Tare timeout	Input of timeout when there is no standstill: 0.1 s...<2.5 s>...25 s
	Zerose range	± Range of zero point when there is no standstill. Input: 0.00 d...<50.00 d>...10000.00 d
	Zerotrack indic. range	Input of the zerotrack indication range: 0.00 d...<0.25 d>...10000.00 d
	Zerotrack step	Input of the zerotrack step: 0.00 d...<0.25 d>...10.00 d
	Zerotrack time	Input zerotrack time: <0.0 s>...25 s
	Overload	Input of the weighing range above the maximum load (Max) without error message: 0...<9 d>...999999 d
	Min	Input of the minimum load: 0 d...<50 d>...999999 d
	Range mode	Range selection: <Single range>, Multiple range, Multi-interval See also Chapters 7.14.15.2 and 7.14.15.3 .
	Range limit 1	Input of the limit 1: In weight, unit same as Max, transition from small to medium verification interval
	Range limit 2	Only for [Multiple range] or [Multi-interval]! Input of the limit 2: In weight, unit same as Max, transition from small to medium verification interval
	LC name	Only for [Multiple range] or [Multi-interval]! Give each load cell a name.
	LC 1...n	load cell 1...n, e.g.: PR6224-xx
	Default	Input of max. 20 alphanumeric characters.
	Service	Settings are reset to factory settings.
	LC 1...n	Service function for load cells: Deactivate/activate load cell. load cell 1...n

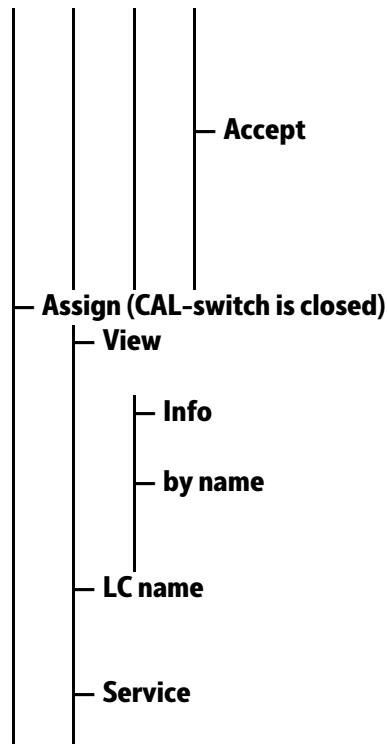

Select the faulty load cell and reset to .
 Select the new (replaced) load cell and mark the checkbox .
 Accept:
 After deactivation the simulation for the deactivated load cell starts.
 Once the replaced load cell has been activated the search process starts.

Item number, serial number and current weight of connected load cells are displayed.
 The data for the selected Loading cell are displayed.
 Change the display from [ID] (LC 1...n + serial number) to [by name] of the load cells; only possible if a load cell name has been assigned.
 Change the display from [ID] (LC 1...n + serial number) to [by name] of the load cells; only possible if a load cell name has been assigned.
 The service window for the load cells is displayed. No change is possible!

7.13.7.4 "Connexx Load Cells" weighing point

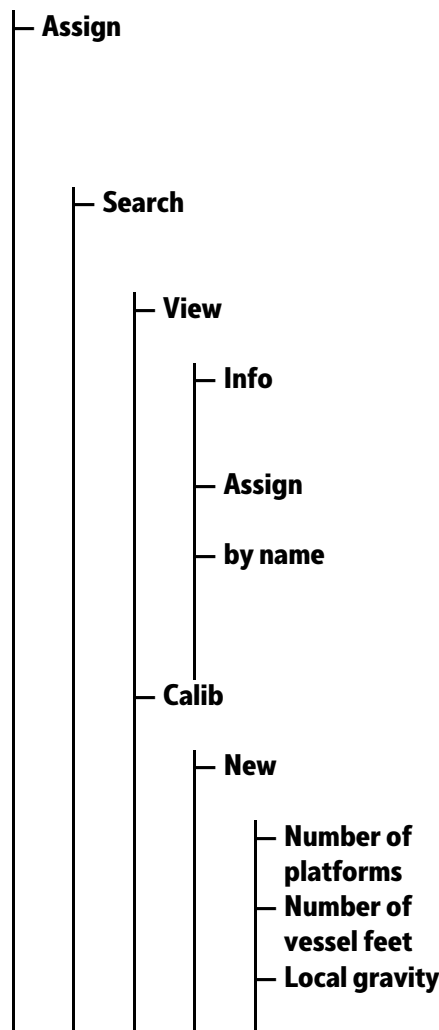

Assignment of the Connexx scale
 Type, number of load cells, serial no. of the individual load cells and weighing point serial number (if already calculated) are displayed (if already searched using "Search").
 Search for connected load cells.
 Search for a new network and reset the load cell data to the factory settings.
 Serial number and current weigh of connected load cells are displayed.
 The data from the selected load cell is displayed.
 Load cells (serial numbers) are assigned to the installation location.
 Change the display of [ID] (LC 1...n + serial number) according to [by name] of the load cells; only possible if a load cell name has been assigned.
 Serial number and current weigh of connected load cells are displayed.
 Prompt window during recalibration: Corner correction will be reset. Yes, No
 Only for load cells PR 6221/...: Only appears when the number of load cells = 8.
 Load cells Inteco®/...: Enter number.
 Enter local gravity (standard: Hamburg 9.81379 m/s²)

				Max	Enter maximum load: 0.000010...<3000>...9999998 <kg>, t, lb, g, mg, oz
				Scale interval	Enter scale interval (1 d): <1>, 2, 5, 10, 20, 50 displayed according to the decimal places at Max and the weight unit.
				Dead load	Dead load: Weight of the empty scale
				CAL weight	Enter calibration weight: 0.000010...9999998 <kg>, t, lb, g, mg, oz
				Corner correction	Platform 1, platform 2 (only appears when the number of load cells = 8). OK, when carried out.
				Modify	Only used for minor changes (e.g. changing the dead load). Otherwise, always use [New]!
				Param	Parameter settings
				Measuretime	Measurement time: The value cannot be changed. It is specified by the Connexx module.
				Digital filter	Selection of the digital filter (filter characteristic): <off> (no filter), Bessel, aperiod. (aperiodic), Butterw. (Butterworth), Tcheby. (Tschebyscheff)
				Fcut	Only if filter is not "off", enter the corner frequency: 0.1–80.0 Hz
				W&M	Select legal-for-trade mode: <none>, OIML, NSC, NTEP
				Unbal. Check deviat.	Unbalanced check deviation: the plausibility check is activated when the average deviation is >0%. Entry: 0...100 %
				Standstill time	Enter the standstill time: 0.01 s...<0.50 s>...2.0 s (range depends on the measurement time).
				Standstill range	Enter the standstill range: 0.00 d...<1.00 d>...10.00 d (range depends on the measurement time).
				Tare timeout	Enter the timeout when there is no standstill: 0.1 s...<2.5 s>...25 s
				Zeroset range	± Range of zero point when there is no standstill. Input: 0.00 d...<50.00 d>...10000.00 d
				Zerotrack indic. range	Enter the zerotrack indication range: 0.00 d...<0.25 d>...10000.00 d
				Zerotrack step	Enter the zerotrack steps: 0.00 d...<0.25 d>...10.00 d
				Zerotrack time	Enter the zerotrack time interval: <0.0 s>...25 s
				Overload	Enter the weighing range above the maximum capacity (Max), without error message: 0...<9 d>...999999 d
				Min	Enter the minimum load: 0 d...<50 d>...999999 d
				Range mode	Range selection: <Single range>, Multiple range, Multi-interval See also Chapter FEHLER and FEHLER .

<ul style="list-style-type: none"> — Range limit 1 — Range limit 2 — LC name <ul style="list-style-type: none"> — LC 1...n — Default — Service <ul style="list-style-type: none"> — LC 1...n — Accept 	<p>Input range limit 1: In weight, unit as for Max, transition from low to medium scale interval Only for [Multiple range] or [Multi-interval]!</p> <p>Input range limit 2: In weight, unit as for Max, transition from low to medium scale interval Only for [Multiple range] or [Multi-interval]!</p> <p>Give each load cell a name. Load cell 1...n, e.g.: PR6203-xx Input max. 20 alphanumeric characters.</p> <p>Settings are reset to factory settings. Service function for load cells: Deactivating/activating the load cell. Load cell 1...n Select the defective load cell and reset the <input checked="" type="checkbox"/> box to <input type="checkbox"/>.</p> <p>Select the new (replaced) load cell and set the box <input checked="" type="checkbox"/>.</p> <p>Accept: After deactivation, the simulation of the deactivated load cell is started. After activation of the replaced load cell, the search process is started.</p>
<ul style="list-style-type: none"> — Assign (CAL switch closed) <ul style="list-style-type: none"> — View <ul style="list-style-type: none"> — Info — by name — LC name — Service 	<p>Item number, serial number and current weight of connected load cells are displayed. The data from the selected load cell is displayed. Change the display of [ID] (LC 1...n + serial number) according to [by name] of the load cells; only possible if a load cell name has been assigned. Change the display of [ID] (LC 1...n + serial number) according to [by name] of the load cells; only possible if a load cell name has been assigned.</p> <p>The service window for the load cells is displayed. No change is possible!</p>

7.13.8 Limit parameter

Note:

This menu item is only available if under -[Operating parameter]- [Application] "Standard" has been selected.

<ul style="list-style-type: none"> — Limit 1...3 on <ul style="list-style-type: none"> — Action — Condition 	<p>Enter 0 – Max (maximum load); take unit from calibration.</p> <p>Action, selection: no action, set marker 1...3, clr (clear) marker 1...3</p> <p>Condition, selection: see Chapter 7.18.7.</p>
---	---

— Limit 1...3 off	Enter 0 – Max (maximum load); take unit from calibration.
— Action	Action, selection: no action, set marker 1...3, clr (clear) marker 1...3
— Condition	Condition, selection: see Chapter 7.18.7 .

7.13.9 Digital I/O parameters

Note:

This menu item is only available if under  - [Operating parameter]- [Application] "Standard" has been selected.

— Output 1...3	Configure outputs, selection: see Chapter 7.18.9 .
— Input 1...3 on	Configure inputs
— Action	Action, selection: see Chapter 7.18.8.1 .
— Condition	Condition, selection: see Chapter 7.18.8.2 .
— Input 1...3 off	Configure inputs
— Action	Action, selection: see Chapter 7.18.8.1 .
— Condition	Condition, selection: see Chapter 7.18.8.2 .

7.13.10 Analog output parameter

— Analog mode	Analog output parameter: Gross D08 = gross, Net if tared D09 = Net if tared, Selected D11 = value on the display, Transparent D30 = Transparent, no output = analog output unused, see Chapter 7.18.10 .
— Analog range	Output range: 0...20 mA, <4...20 mA>
— Output on error	Output on error: 0 mA = set to 0 mA, <4 mA> = set to 4 mA, 20 mA = set to 20 mA, hold = last output value remains unchanged
— Output if <0	Output if <0: set 0 mA = 0 mA, set <4 mA> = 4 mA, set 20 mA = 20 mA, linear = goes below 4 mA down to the limit (with 4...20 mA), absolute = absolute value
— Output if >Max	Output if >Max: set 0 mA = 0 mA, set 4 mA = 4 mA, set <20> mA = 20 mA, linear = exceeds 20 mA up to the limit
— Weight at 0/4 mA	Weight value for 0/4 mA output
— Weight at 20 mA	Weight value for 20 mA output

7.14 Calibrating internal weighing point

7.14.1 General information

For PR 5410/00, ../00, /01, /03

For legal-for-trade application select  - [Weighing point]- [Calib]- [Param], where the [W & M] must be set to "OIML" before calibration is started; see Chapter [7.14.15](#).

Only for PR 5410/04

The PR 5410/04 does not have legal-for-trade approval.

The legal-for-trade application of PR 5410/04 with other devices has to be verified.

The calibration data are protected by the CAL switch (see Chapter 7.1.3.1), which is sealed in the closed (write-protected) position for legal-for-trade applications.

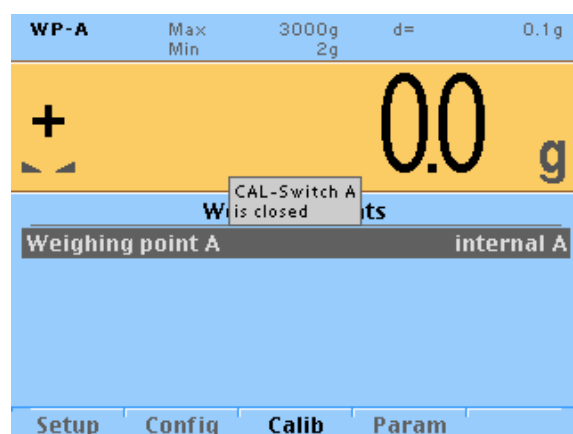
7.14.2 Displaying calibration data**7.14.2.1 Overwrite protection via a CAL switch**

When the CAL switch is closed, a tool tip is displayed.

The screenshot shows the scale's main display with a yellow background. At the top, it displays 'WP-A', 'Max 3000g', 'Min 2g', 'd= 0.1g'. The central display shows a large '0.0 g' with a '+' sign and a small 'ts' indicator. Below the display, the menu bar has 'Setup', 'Config', 'Calib', and 'Param' options. The 'Calib' menu is selected, showing the following data:

Weighing points/WP A/Calibration		
Max	30000 d	3000.0 g
Scale interval	30000 d	0.1 g
Dead load at	87.171 g	0.021981 $\frac{mV}{V}$
Max at	3000.000 g	0.756486 $\frac{mV}{V}$
Calibrated at	2516.59 g	0.634588 $\frac{mV}{V}$
Sensitivity	63.04 $\frac{mV}{d}$	0.302594 $\frac{\mu V}{d}$

The screenshot shows the scale's main display with a yellow background. At the top, it displays 'WP-A', 'Max 3000g', 'Min 2g', 'd= 0.1g'. The central display shows a large '0.0 g' with a '+' sign and a small 'ts' indicator. Below the display, the menu bar has 'Setup', 'Config', 'Calib', and 'Param' options. The 'Param' menu is selected, showing the following data:

Weighing points/WP A/View Calibration	
Measuretime	160 ms
Digital filter	off
External supply	below or equal 8V
Test mode	Absolute
W & M	none
Standstill time	0.50 s

The Data under [Calib] and [Param] is displayed only.

The calibration data and parameters are displayed in the format entered/determined during calibration.

Note:

[Calibrated at]: CAL weight and corresponding mV/V

After input with mV/V, the full scale interval and the mV/V value entered are displayed.

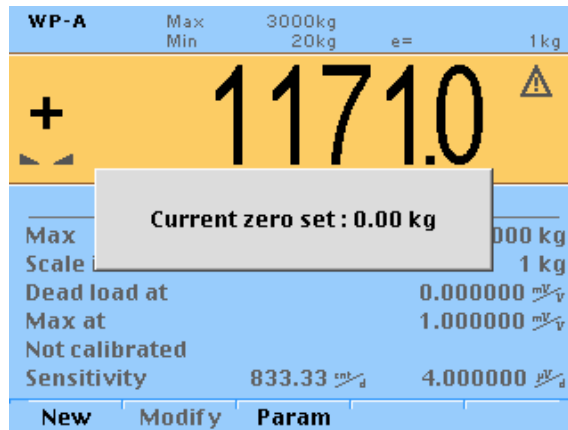
7.14.2.2 Increased resolution (10-fold)

In the -[Weighing point]- [Calib] menu the weight is displayed with 10-fold resolution (also with the CAL switch closed) with .

After 5 seconds the display returns to normal resolution. Press if you want to switch to normal resolution immediately.

If the parameter "OIML" for the weighing point under [W&M] is selected, the weight value is marked as an invalid weight with the symbol.

7.14.3 Selecting the calibration mode**Note:**

The [Modify] menu item is only used for small changes (e.g. changing the dead load/preload, changing the mV/V values for dead load/preload and/or Max, changing the scale interval). Otherwise select the [New] menu item.

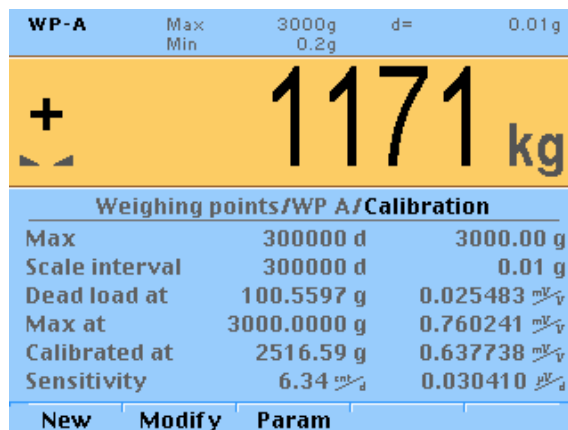

Under - [Weighing point] - [Calib] choose between [New] and [Modify].

7.14.3.1 Performing a new calibration

1. Select -[Weighing point]- [Calib] and confirm.

WP-A			
Max	3000g	d=	0.01g
Min	0.2g		
+ 1171 kg			
Weighing points/WP A/Calibration			
Max	300000 d		3000.00 g
Scale interval	300000 d		0.01 g
Dead load at	100.5597 g		0.025483 $\frac{mV}{V}$
Max at	3000.0000 g		0.760241 $\frac{mV}{V}$
Calibrated at	2516.59 g		0.637738 $\frac{mV}{V}$
Sensitivity	6.34 $\frac{mV}{a}$		0.030410 $\frac{\mu V}{a}$
New Modify Param			

2. Press the [New] softkey.
 - ▷ A prompt window opens.

WP-A			
Max	3000kg	d=	1kg
Min	20kg		
+ 1171 kg			
?			
Span and dead load will be reset.			
Continue		Cancel	
New			

3. By pressing [Continue] the data are reset to default first (default) before performing calibration. Press [Cancel] to cancel selection.
4. Determining the maximum load [Max], see Chapter [7.14.4](#).
5. Determining the scale interval [Scale interval], see Chapter [7.14.5](#).
6. Determining the dead load [Deadload at], see Chapter [7.14.6](#).
7. Calibrating with load [Max at], see Chapter [7.14.7](#).
8. Calibrating with mV/V [Max at], see Chapter [7.14.8](#).
9. Calibrating with load cell data (smart calibration) [Max at], see Chapter [7.14.8.1](#).
10. Carrying out linearization, see Chapter [7.14.11](#).

7.14.3.2 Modifying a calibration

Note:

[Modify] may be used only for minor changes (e.g. changing the dead load, adapting mV/V values for dead load and/or Max). Otherwise, always use [New]!

Example:

Resetting the Dead Load

1. Select -[Weighing point]- [Calib] and confirm.

WP-A	Max	3000g	d=	0.01g
	Min	0.2g		
+ 1171 kg				
Weighing points/WP A/Calibration				
Max	300000 d	3000.00 g		
Scale interval	300000 d	0.01 g		
Dead load at	100.5597 g	0.025483 mV/V		
Max at	3000.0000 g	0.760241 mV/V		
Calibrated at	2516.59 g	0.637738 mV/V		
Sensitivity	6.34 mV/d	0.030410 μV/d		
New Modify Param				

2. Press the [Modify] softkey.

WP-A	Max	3000kg	d=	0.1kg
	Min	2kg		
+ 1171.2 kg				
Weighing points/WP A/Calibration				
Max	30000 d	3000.0 kg		
Scale interval	30000 d	0.1 kg		
Dead load at		0.000000 mV/V		
Max at		1.000000 mV/V		
Not calibrated				
Sensitivity	83.33 mV/d	0.400000 μV/d		
by load by mV/V CalcTest				

3. Choose the [Deadload at] menu item.
4. Either press the [by mV/V] softkey to enter the value again or clear the scale/hopper and press the [by load] softkey to reset the dead load.
5. Press  to exit the calibration.
 - ▷ A prompt window opens.

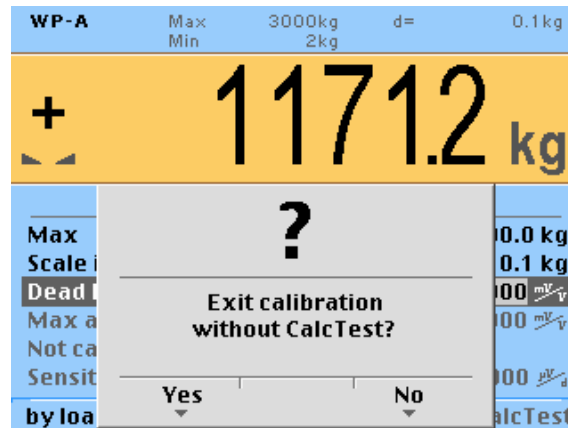

6. Press the [Yes] softkey to close the menu without calculation of the test value.
7. Press  to exit the calibration for good.
 - ▷ A prompt window opens.

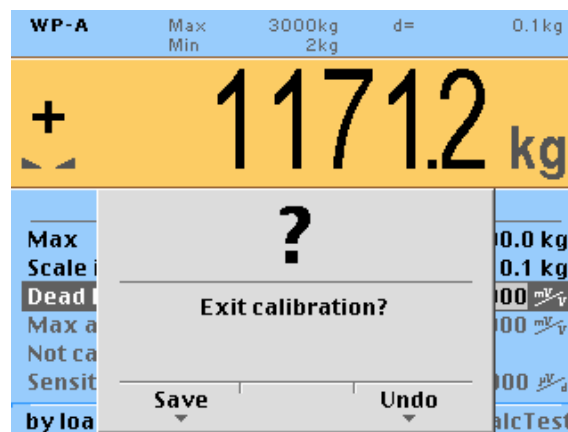

8. Press the [Save] softkey to save changes in calibration data.

7.14.4 Setting maximum load

The maximum load (Max) determines the maximum weight without dead load of the weight to be measured and the displayed number of digits behind the decimal point. Normally, Max is less than the load cell capacity (maximum capacity x number of load cells).

Permissible values for the maximum load are:

Max weight value from 0.00010 to 999999 in t, kg, g, or lb.

Maximum weight value must be an integer multiple of the scale interval (1 d). It may have up to 6 digits and is entered as a numeric value with or without a decimal point.

WP-A		Max	3000kg	d=	0.1kg
		Min	2kg		
+ 1171.0 kg					
Weighing points/WP A/Calibration					
Max	30000 d		3000.0 kg		
Scale interval	30000 d		0.1 kg		
Dead load at			0.000000 $\frac{mV}{V}$		
Max at			1.000000 $\frac{mV}{V}$		
Not calibrated					
Sensitivity	83.33 $\frac{mV}{d}$		0.400000 $\frac{\mu V}{d}$		
CalcTest					

1. Enter the [Max] load with decimal places (in this example: 3000.0).
2. Press ABC to select the weight unit.
3. Confirm entries with OK or \downarrow .
 - ▷ The verification is displayed by "Setting Max...".

Note:

Error messages, calibration see Chapter [16.4](#).

7.14.5 Determining the scale interval

The scale interval (d) is the difference between two successive display values.

With a scale used in legal metrology, this value is called the verification scale interval (e), which corresponds to the scale interval: $d = e$.

Example:

Max = 6000 kg

Scale interval (1 d) = 2 kg

Calculation for scale interval for Max (automatic):

$d = \text{Max} / \text{scale interval (1 d)}$

$d = 6000 \text{ kg} / 2 \text{ kg}$

$d = 3000$

Procedure:

The weight unit is taken from [Max]. The number of digits behind the decimal point is also automatically determined when [Max] is entered.

WP-A			
Max	3000kg	d=	0.1 kg
Min	2kg		
+ 1171.2 kg			
Weighing points/WP A/Calibration			
Max	30000 d		3000.0 kg
Scale interval	30000 d	↕	0.1 kg
Dead load at			0.000000 $\frac{mV}{V}$
Max at			1.000000 $\frac{mV}{V}$
Not calibrated			
Sensitivity	83.33 $\frac{cnt}{d}$		0.400000 $\frac{\mu V}{d}$
CalcTest			

1. Select [Scale interval] and confirm by pressing OK or \rightarrow .
 ▷ A selection window opens.
2. Select the scale interval (1 d) and confirm with OK .
 ▷ The scale interval (d) is then calculated, based on the Max weight value.
 The verification is displayed by "Setting Scale interval...".

Note:

Error messages, calibration see Chapter [16.4](#).

7.14.6 Determining the dead load**Note:**

If a linearization was carried out (see Chapter [7.14.11](#)), the following note appears on the display after the [Dead load at] line is selected:

Cannot be changed here while linearization is active.

Changes cannot be made while linearization is switched on.

Only deleting of the linearization points deactivates the linearization mode!

WP-A		Max	3000kg	d=	0.1kg
		Min	2kg		
+		1171.2 kg			
Weighing points/WP A/Calibration					
Max	30000 d	3000.0 kg			
Scale interval	30000 d	0.1 kg			
Dead load at		0.000000 $\frac{mV}{V}$			
Max at		1.000000 $\frac{mV}{V}$			
Not calibrated					
Sensitivity	83.33 $\frac{mV}{d}$	0.400000 $\frac{\mu V}{d}$			
by load		by mV/V		CalcTest	

To use the empty scale/hopper as dead load (normal case):

1. Clear the scale/hopper.
2. Press the [by load] softkey.
3. Confirm entries with OK or \downarrow .
 - ▷ The verification is displayed by "Setting dead load...".

Note:

If the mV/V value of the dead load was calculated, or if it is known from the previous calibration, the value can be overwritten by pressing [by mV/V].

Error messages, calibration see Chapter 16.4.

7.14.7 Calibrating with weight

Note:

If a linearization was carried out (see Chapter 7.14.11), after selection of the line [Max at] the following tip is displayed:

Cannot be changed here while linearization is active.

Changes cannot be made while linearization is switched on.

Only deleting of the linearization points deactivates the linearization mode!

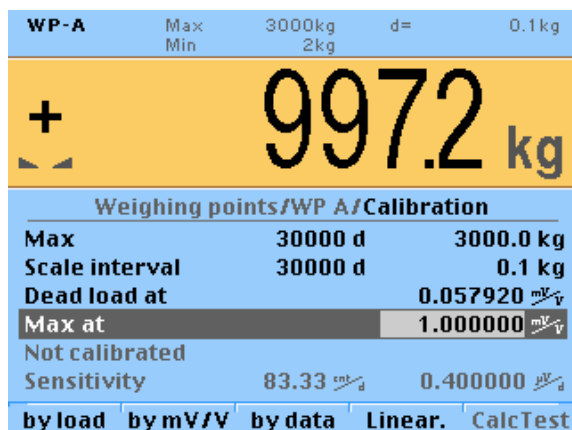

1. Press the [by load] softkey.

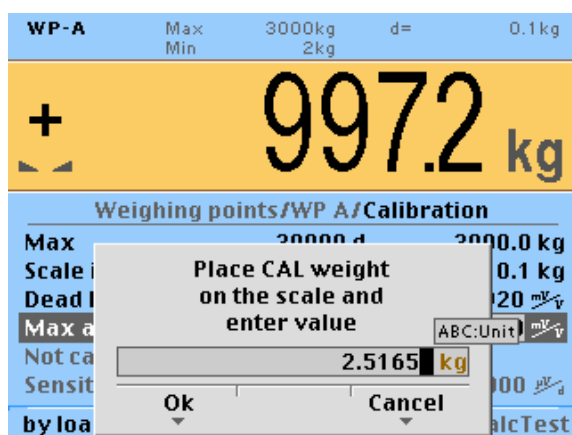

2. Place the CAL weight on the scale.
3. Enter the weight of the CAL weight.
4. Confirm the entries.
5. Press ABC to select the weight unit.

The weight unit for the CAL weight may differ from the unit in the device. Conversion is automatic.

6. Confirm entries with OK or \downarrow .

▷ The verification is displayed by "Setting Span by load...".

Weight value, weight unit and measuring signal in mV/V corresponding to this value are displayed in the line [Calibrated at].

Note:

Error messages, calibration see Chapter [16.4](#).

7.14.8 Calibrating with mV/V

The scale can be calibrated without weights. During input of the load cell mV/V value, the acceleration of gravity at the place of installation can be taken into account.

The PR- load cell data is based on the acceleration of gravity in Hamburg, Germany:

9.81379 m/s².

WP-A		Max	3000kg	d=	0.1kg
		Min	2kg		
+		997.2 kg			
Weighing points/WP A/Calibration					
Max	30000 d	3000.0 kg			
Scale interval	30000 d	0.1 kg			
Dead load at		0.057920 mV/V			
Max at		1.000000 mV/V			
Not calibrated					
Sensitivity	83.33 mV/d	0.400000 μV/d			
by load by mV/V by data Linear. CalcTest					

1. Calculating SPAN value for Max and, if necessary, for the dead see Chapter 7.14.8.1.
2. Press the [by mV/V] softkey.

WP-A		Max	3000kg	d=	0.1kg
		Min	2kg		
+		997.2 kg			
Weighing points/WP A/Calibration					
Max	30000 d	3000.0 kg			
Scale interval	30000 d	0.1 kg			
Dead load at		0.057920 mV/V			
Max at		1.000000 mV/V			
Not calibrated					
Sensitivity	83.33 mV/d	0.400000 μV/d			
by load by mV/V by data Linear. CalcTest					

Enter input voltage
for SPAN

1.000000 mV/V

Ok Cancel

3. Entering the SPAN value for Max and, if necessary, for the subsequent correction of dead load (see Chapter 7.14.10).
4. Confirm the entries.
 - ▷ The verification is displayed by "Setting Span mV/V...".

Weight value, weight unit and measuring signal in mV/V corresponding to this value are displayed in the line [Calibrated at].

Note:

Error messages, calibration see Chapter 16.4.

7.14.8.1 Calculating SPAN value

Calculating SPAN

SPAN indicates the equivalent input voltage in mV/V related to the maximum capacity (Max) of the scale. It is calculated as follows:

$\text{SPAN [mV/V]} = \text{maximum capacity} \times \text{load cell sensitivity } C_n \text{ [mV/V]} / \text{load cell capacity (maximum capacity } E_{\text{max}} \times \text{number of load cells)}$

load cell sensitivity $C_n = \text{rated output } C_n$ (see technical data for the load cell)

Calculate dead load

The input voltage in mV/V equivalent to the dead load can be calculated by using the dead load rather than the maximum capacity in the formula specified above.

Normally, calculation of the dead load (scale without load or empty vessel) is not necessary.

Subsequent dead load correction (see Chapter [7.14.10](#)) can be used for later re-determination of the dead load, when the scale or vessel is empty.

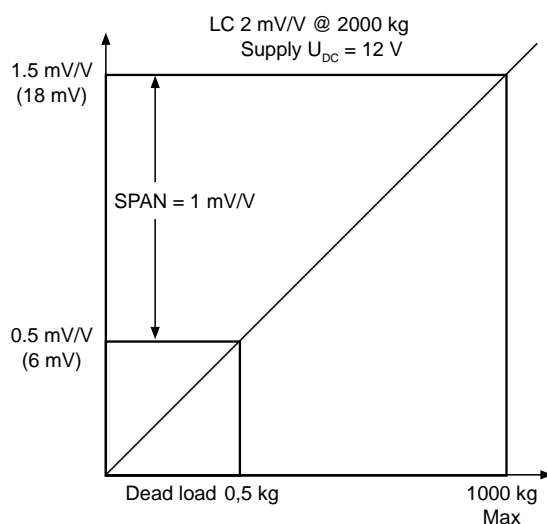

Example

- 1 load cell with rated output $C_n = 2 \text{ mV/V}$
- At maximum capacity 2000 kg
- Maximum capacity 1000 kg
- Dead load 500 kg
- Load cell supply voltage $U_{DC} = 12 \text{ V}$

7.14.9 Calibrating with load cell data (smart calibration)

If the scale is not used in legal metrology, calibration without weights can be performed. The easiest method is the one using load cell data without calculation.

WP-A	Max Min	3000kg 2kg	d=	0.1 kg
+ 997.2 kg				
Weighing points/WP A/Calibration				
Max		30000 d		3000.0 kg
Scale interval		30000 d		0.1 kg
Dead load at				0.057920 $\frac{mV}{V}$
Max at				1.000000 $\frac{mV}{V}$
Not calibrated				
Sensitivity		83.33 $\frac{mV}{d}$		0.400000 $\frac{\mu V}{d}$
by load by mV/V by data Linear. CalcTest				

1. Press the [by data] softkey.

WP-A	Max Min	3000kg 2kg	d=	0.1 kg
+ 1171.3 kg				
... /WP A/Calibration/load cell configuration				
Number of loadcells				4
max. capacity of load cell				3000 kg
Gravity				9.81379 m/s^2
Hysteresis error				not specified
Certified data				all LC same
LC output at max. capacity				1.000000 $\frac{mV}{V}$
Enter Calc				

[Number of load cells]

Number of load cells connected in parallel

Input: 1, 2...<4>...9, 10

[max. capacity of load cell]

Maximum capacity E_{max} of a load cell (not the total maximum capacity of the scale!)

Input: For the value refer to the technical data of the load cell.

[Gravity]

Gravity at place of installation

Default is the value for Hamburg, Germany: $9.81379 m/s^2$.

[Hysteresis error]

Hysteresis error

When switching from [not specified] to [specified] values for [Correction A/B] must be entered. For this data refer to the load cell certificate.

[Certified data], [LC output at max. capacity], [LC output impedance]

LC = load cell

When [all LC same] is set, only one value for [LC output at max. capacity] and [LC output impedance] are required.

For [each LC specific] press the [Enter] softkey to enter individual data for each load cell.

2. Press the [Calc] softkey to start the calculation.
3. Confirm the calculation by pressing the [Ok] softkey to save the calculated mV/V value to the calibration data.

7.14.10 Subsequent dead load correction

If the hopper/platform weight changes by an amount that is higher than the zero-setting range; e.g. due to dead load reduction, dead load increase, or mechanical changes, the functions for automatic zero tracking and manual zero setting no longer work.

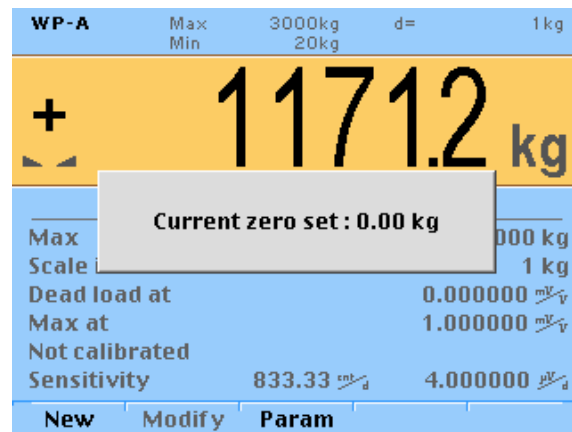

To view the range which is already utilized by zero tracking or zero setting, in [Calibration] press the  key; this also activates 10-fold increased resolution of the weight value.

Note:

The scale must not be loaded!

If the full zero-setting range is already being utilized, you can still correct the dead load (overwrite protection must be deactivated, see Chapter 7.1.3.1) without affecting other calibration data/parameters. To do this select -[Weighing points]- [Calib]- [Modify] and determine the dead load with [Dead load at] using the [by load] option (see Chapter 7.14.6).

Note:

If a linearization was carried out (see Chapter 7.14.11), the following note appears on the display after the [Dead load at] line is selected:

Cannot be changed here while linearization is active.

Changes cannot be made while linearization is switched on.

Only deleting of the linearization points deactivates the linearization mode!

7.14.11 Linearization

The measurement range for a straight can be optimized by setting the linearization points.



Requirements:

Calibration of Max and dead load was done.

7.14.12 Calculating the test value

The calculation of the test value is called by pressing the [CalcTest] softkey.

The maximum load (Max) is displayed with the ID TST without a weight unit. The value determined during calibration by pressing the [CalcTest] softkey after starting the test is displayed.

Depending on the settings under  - [Weighing point] - [Calib] - [Param] - [Test mode] the following is displayed by calling the Test with the  key later on:

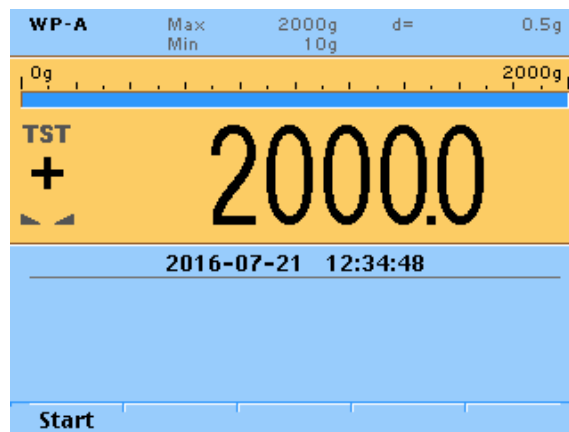

- with [Absolute] the maximum load
- with [Relative] the deviation from the test value

7.14.13 Saving the calibration

Quit calibration by pressing the  softkey.

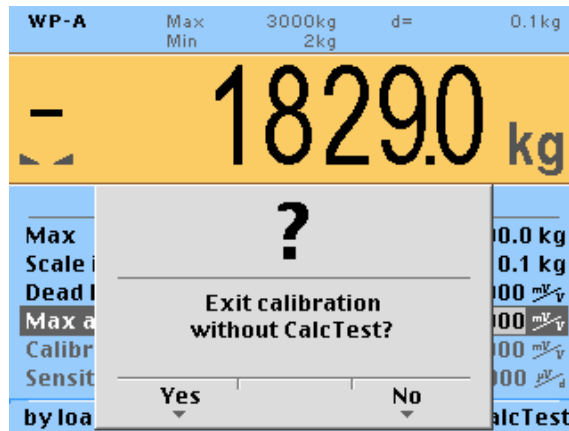

You are prompted to confirm whether calibration should be closed without determining the test value.

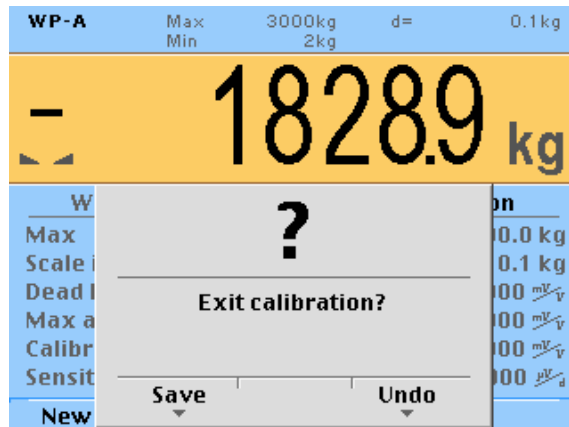

By pressing [Save] altered calibration data are saved.

The verification is displayed by "Saving calibration".

Leaving the menu is displayed by "Exit calibration".

After finishing the calibration, set the CAL switch to the closed position; see also Chapter [7.1.3.1](#).

7.14.14 Cancelling a calibration

Quit calibration by pressing the ^{Exit} softkey.

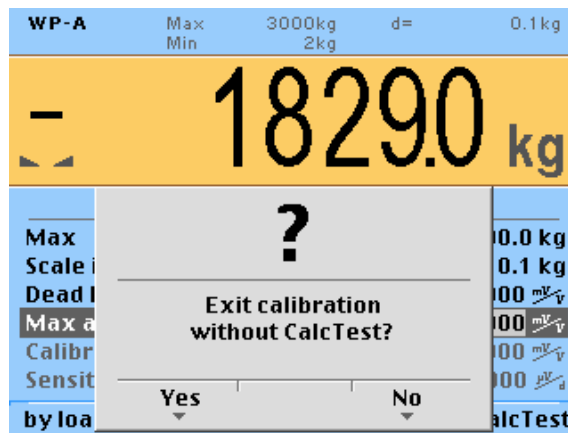

You are prompted to confirm whether calibration should be closed without determining the test value.

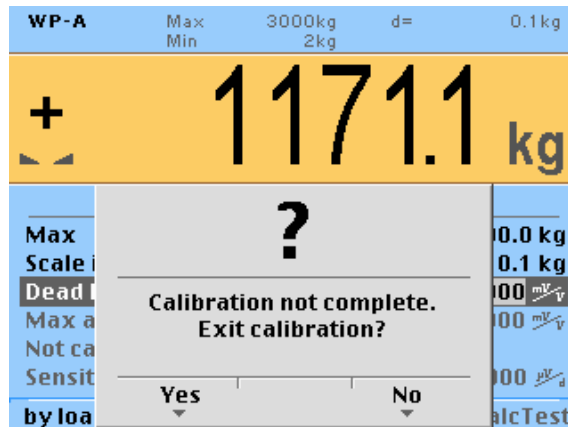

If not all data was determined when calibrating with [New] (e.g. dead load not set/entered), this message is shown:

Press [Yes] to confirm and then press again the ^{Exit} softkey, another prompt is displayed:

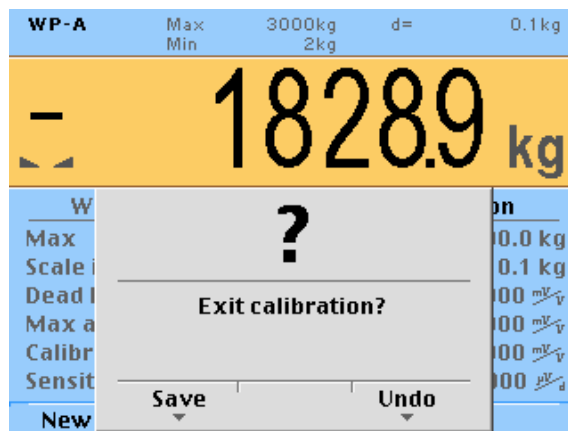

If you press [Undo], changes are not saved and the display returns to the selection menu for the weighing points.

Leaving the menu is displayed by "Exit calibration".

7.14.15 Parameter Input

The menu is accessible via  - [Weighing point] - [Calib] - [Param] .

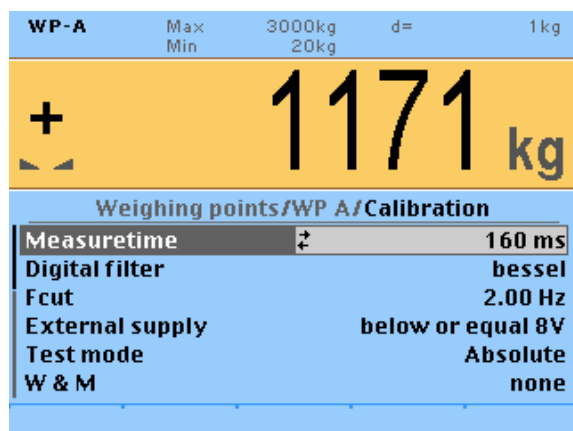

[Measurementtime]

Measuring time: The duration of a measurement can be selected.

Selection: 5 ms, 10 ms, 20 ms, 40 ms, 80 ms, 160 ms, <320 ms>, 640 ms, 960 ms, 1280 ms, 1600 ms.

[Digital filter]

Selection of the digital filter (filter characteristic): <off> (no Filter), Bessel, aperiod. (aperiodic), Butterw. (Butterworth), Tcheby. (Tschebyscheff)

The following includes examples of interference signals for the different filter types:

Bessel filter

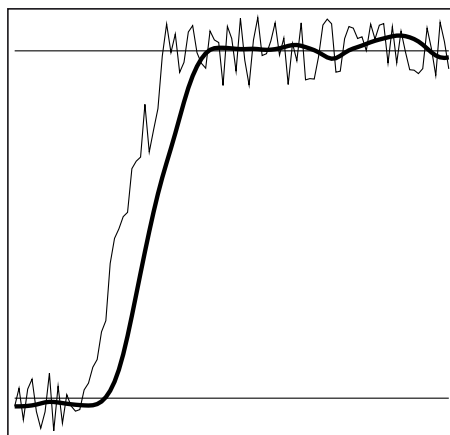

Aperiodic filter

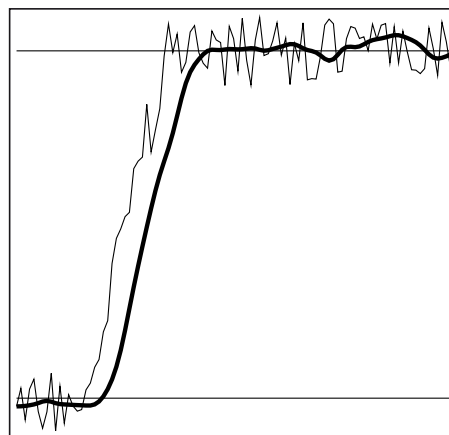

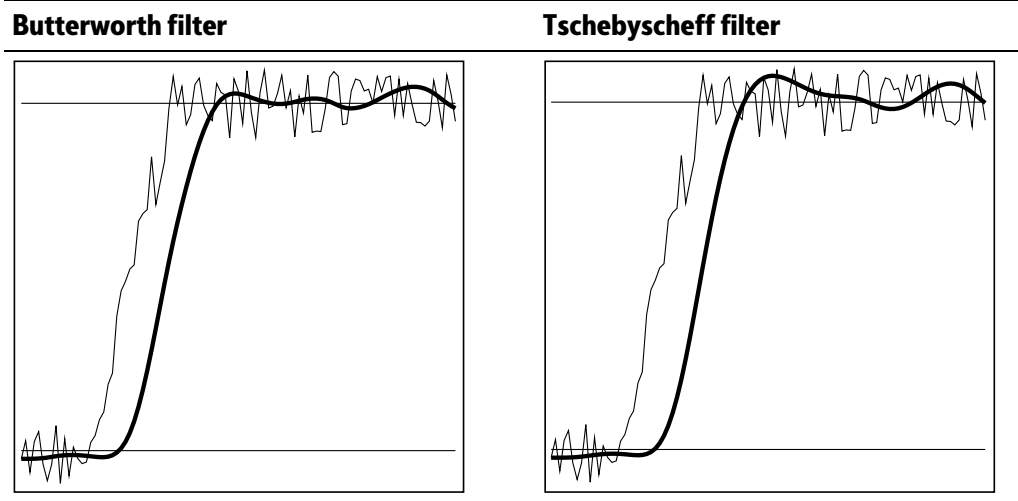

A digital filter can be switched on only with the measuring time set to <160 ms.

If no particularly frequent fluctuations are expected in ongoing operation, the following settings are recommended:

[Measuretime]: <160 ms

[Digital filter]: aperiod.

[Fcut]: 2.00 Hz

[Fcut]

This line only is shown if the digital filter is switched on.

The smaller the cut-off frequency, the slower the measurement and the more stable the measurement result.

The cut-off frequency can be specified for the low pass filter.

Valid range: 0.1...2.5 Hz.

The available options depend on the measuring time.

[External supply]

Without function, see Chapter [4.6.7](#).

[Test mode]

With [absolute], the test value is determined when the test is called.

With [relative], the deviation from the initially stored test value is displayed; see Chapter [7.14.12](#).

[W&M]

See Chapter [7.14.15.1](#).

If [OIML] was selected, the device needs to warm up for 30 seconds.

[Standstill time]

The parameters [Standstill time] and [Standstill range] are used to define the stability of the scale (stable balance).

The input for the parameter [Standstill time] is expressed in seconds.

Valid range: 0.00...2 s

If the tone is set to "0" there is no check. The standstill time must not be less than the measuring time.

[Standstill range]

As long as the weight fluctuations remain within this range, the device is determined to be stable.

The input for the parameter [Standstill range] is expressed in "d."

Valid range: 0.01...10.00 dc.

[Tare timeout]

Timeout for a tare/zeroreset command that cannot be executed (e.g. due to mechanical instability of the scale, incorrect filter setting, resolution too high, standstill condition too strict).

The input is done as seconds.

Valid range: 0.0...<2.5>...25 s.

At 0.0 s taring is only carried out when the scale is already stable.

[Zerosest range]

Define a \pm range around the zero point determined by the dead load during calibration; within this range

- the displayed gross weight can be set to zero by pressing the zero-setting key (or by a corresponding external command), and
- automatic zero tracking is active.

Setting range: 0.00...10000.00 d

For use in legal metrology a value $\leq 2\%$ of the Max must be entered, example: 60 d for 3000 e of class III.

[Zerotrack indic. range]

Indication range within which automatic zero tracking compensates deviations.

Setting range: 0.25...10000.00 d

In "legal-for-trade" mode a value of < 0.5 d has to be entered.

[Zerotrack step]

If a weight change exceeds the adjusted value, automatic tracking does not function any more.

Setting range for automatic tracking increments: 0.25...10 d

In "legal-for-trade" mode a value of ≤ 0.5 d has to be entered.

[Zerotrack time]

Time interval for automatic zero tracking.

Setting range: 0.1...25 s

At 0.0 s the zero tracking is switched off.

For use in legal metrology a value of 1 s must be entered.

[Overload]

Weighing range above the maximum load (Max) without error message.

Setting range: 0...9999999 d

For use in legal metrology a value of max. 9 d = e must be set.

[Minimum weight]

Minimum weight at which a print command can be triggered.

Setting range: 0...9999999 d

For use in legal metrology a value of at least 20 d must be set.

[Range mode]

Selection: <Single range>, Multiple range, Multi-interval

For scale range selection, see Chapter [7.14.15.2](#) and [7.14.15.3](#).

Press the  softkey to exit the menu and to save the settings.

7.14.15.1 Legal-for-trade mode

In the menu -[Weighing point]- [Calib]- [Param]- [W&M] you can choose between [none] and the legal-for-trade modes [OIML], [NTEP], or [NSC].

	[none]	[OIML]	[NTEP]	[NSC]
Gross weight display	B	B	G	G
Recommended min. measurement signals	0.125 mV/V @ 30,000 d	0.125 mV/V @ 3000 e	0.125 mV/V @ 3000 e	0.125 mV/V @ 3000 e
	0.25 mV/V @ 60,000 d	0.25 mV/V @ 6000 e	0.25 mV/V @ 6000 e	0.25 mV/V @ 6000 e
		0.42 mV/V @ 10,000 e	0.42 mV/V @ 10,000 e	0.42 mV/V @ 10,000 e

If legal-for-trade mode is switched on, the parameter settings (zero tracking etc.) must be selected accordingly. The device does not perform a check of this.

The CAL switch (see Chapter [7.1.3.1](#)) must be sealed in the closed position.

Note:

In the W&M mode an invalid weight without weight unit is shown.

7.14.15.2 Multiple range scale (Class III or single range scale Class I and II with variable scale interval)

The multiple range scale is a scale with two or more weighing ranges with different maximum loads and scale intervals. There is only one load receptor, with each range covering zero to its maximum load.

When [Range mode] = [Multiple range], the scale has up to three ranges with different resolution.

The weight display header includes the current range (R1, R2, and R3), Max, Min, and d (or e with instruments used in legal metrology) (example: multiple range scale in range 2):

```
WP-A R2 Max 2000kg d= 2kg
      Min 40kg
```

The [Range limit 1] and [Range limit 2] switch points are the range limits.

As soon as the gross weight exceeds range 1, the next highest range with the next highest scale interval becomes valid (1->2->5->10->20->50).

When reducing the weight, the interval of the previous range is kept. When the gross weight is ≤ 0.25 d of range 1, the scale is stable and not tared, the scale returns to range 1 with the corresponding scale interval.

Note:

During calibration, the multiple range function is always switched off.

Example:

Range mode: "Multiple range"

Range 1: 0...1000 kg (when calibrating set scale interval: 1 kg)

Range 2: 0...2000 kg (next highest scale interval: 2 kg)

Range 3: 0...3000 kg (next highest scale interval: 5 kg)

1. Choose "Range mode" from the -[Weighing point]- [Calib]- [Param] menu.

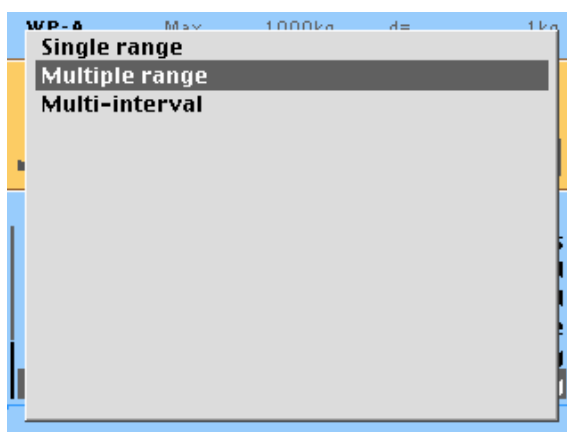

2. Select "Multiple range" and confirm.

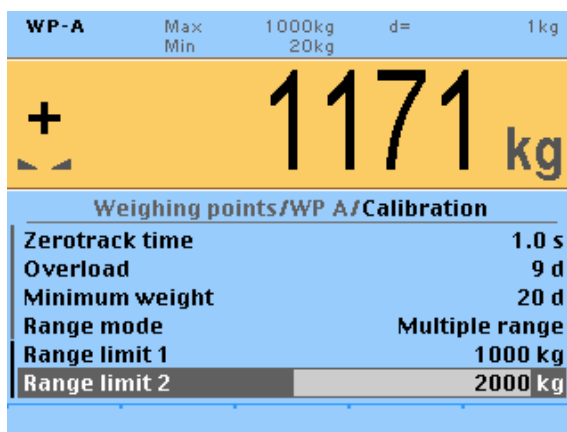

3. Setting Switch point from range 1 to 2: enter "1000 kg" for the Range limit 1.
4. Setting Switch point from range 2 to 3: enter "2000 kg" for the Range limit 2.
5. Press the  softkey to exit and save calibration.

7.14.15.3 Multi-interval scale (Class III or single range scale Class I and II with variable scale interval)

The multi-interval scale is a scale with a weighing range that is divided into intervals. Each interval range has a different scale interval, where the weighing range is automatically switched depending on the load on the scale and also when the load is placed on/ removed from the scale.

When [Range mode] = [Multi-interval], the scale has up to three ranges with different resolution.

The weight display header includes the current interval range (R1, R2, or R3), Max, Min, and d (or e with instruments used in legal metrology) (Example: multi-interval scale in range 2):

WP-A	R1	Max	1500kg	d=	1kg
		Min	20kg		

The parameters [Range limit 1] and [Range limit 2] are the interval ranges.

As soon as the displayed weight exceeds range 1, the next highest range with the next highest scale interval becomes valid (1->2->5->10->20->50).

Note:

During calibration, the multi-interval function is always switched off.

Example:

Range mode: "Multi-interval"

Interval range 1: 0...1500 kg (when calibrating set scale interval: 1 kg)

Interval range 2: 1500...2900 kg (next highest scale interval: 2 kg)

1. Choose "Range mode" from the -[Weighing point]- [Calib]- [Param] menu.

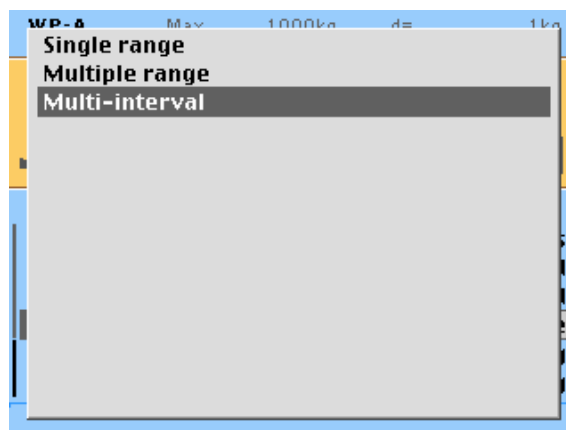

2. Select "Multi-interval" and confirm.

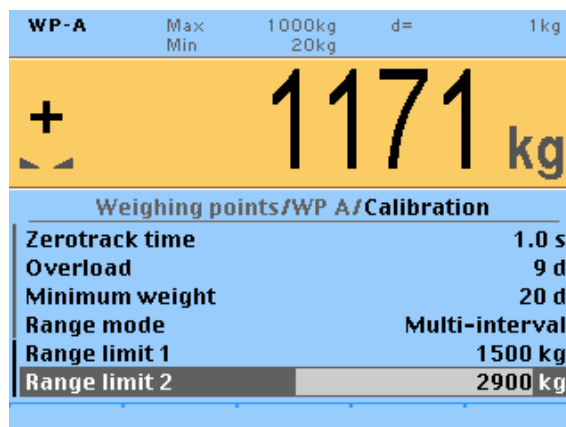

3. Setting interval range 1: Enter "1500 kg" for range limit 1.
4. Setting interval range 2: Enter "2900 kg" for range limit 2.
5. Press the  softkey to exit and save calibration.

7.15 Calibrating xBPI-scale

7.15.1 General information

The legal-for-trade application of PR 5410 with a xBPI-scale is not possible.

7.15.2 Parameters for serial interface

1. Select -[Serial ports parameter]- [xBPI-Port] and confirm.
 ▷ The following window opens:

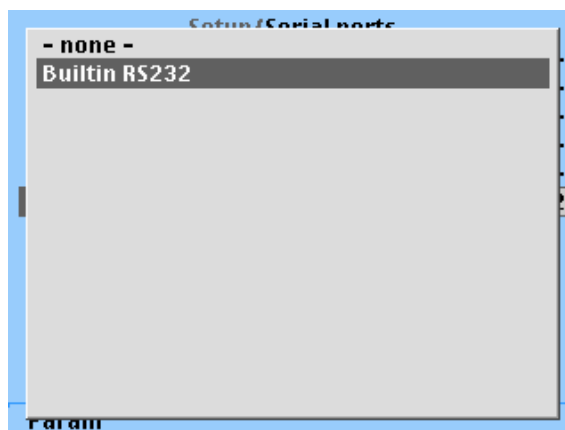

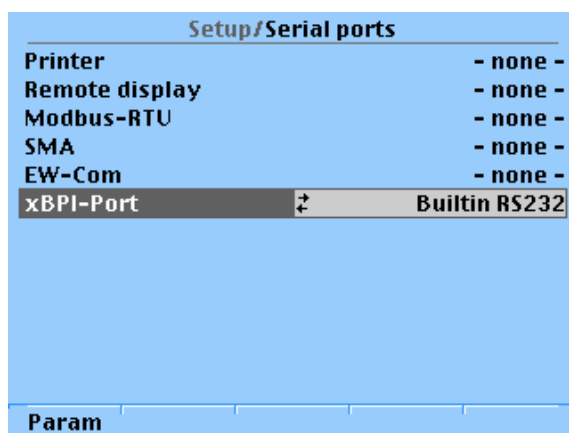

2. Select the desired interface and confirm.

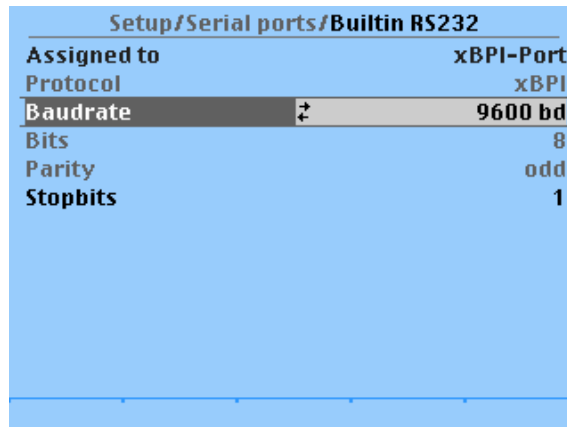

3. Press the [Param] softkey.

- ▷ The following window opens:



- If necessary, change the parameters. Only the "baudrate" and "stop bits" can be set for an xBPI scale.
- Press  to exit the menu and to save the settings.

7.15.3 Parameters for the xBPI-weighing function

The following parameters must be entered for this menu item:

- Timeout for tare function depending on the application
 - SBN-address for each xBPI-scale in bus operation mode
 - Serial number of the xBPI-scale or weighing mode with legal-for-trade application
- Select -[Weighing point]- [xBPI-Scale] and confirm.

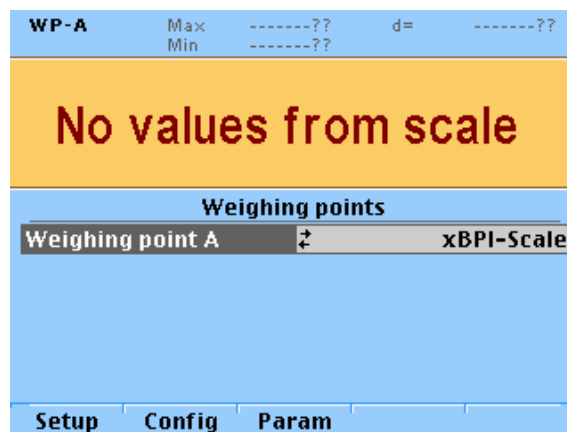

- Press the [Config] softkey.

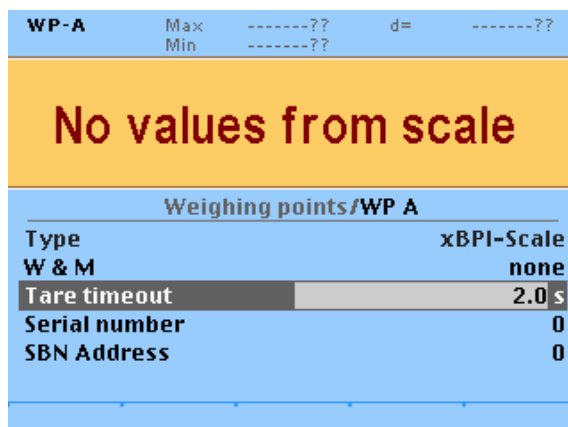

3. Enter the following parameters.

[Tare timeout]

Timeout for a zeroset or tare command to be executed.

If the xBPI scale has not executed the command in the specified time, the action will be aborted.

Setting range: 0...9.9 s

[Serial number]

Serial number of the connected xBPI scale/weighing module.

The number is required for checking when used in legal metrology.

With serial number "0", checking is omitted.

Setting range: 0...99999999

[SBN Address]

When the address is not set to 0, bus operation is active. Possible addresses: 1–31, i.e., max. 31 xBPI scales can be operated on an RS-485 branch.

WP-A.31	Max	3000kg	d=	1 kg
	Min	20kg		

The SBN Address is shown on the display.

Example: Address 31 at WP-A

4. Press  to exit the menu and to save the settings.

7.15.4 Setting up an xBPI platform

1. Select -[Weighing point]- [xBPI-Scale] and confirm.

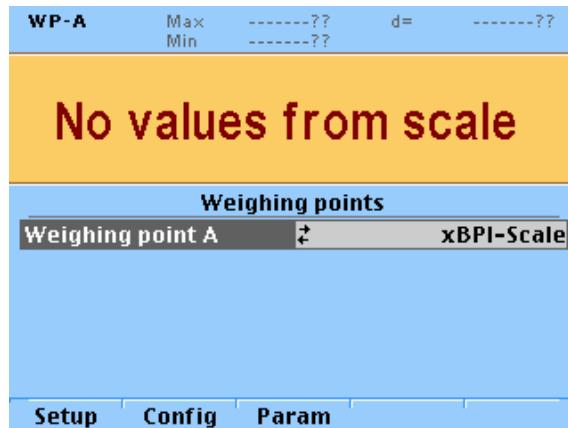

2. Press the [Setup] softkey.

▷ The parameters of the xBPI-scale are read into the device.

Ticks indicate the progress.

An error message is displayed if communication with the xBPI scale is not possible!

The following window opens:

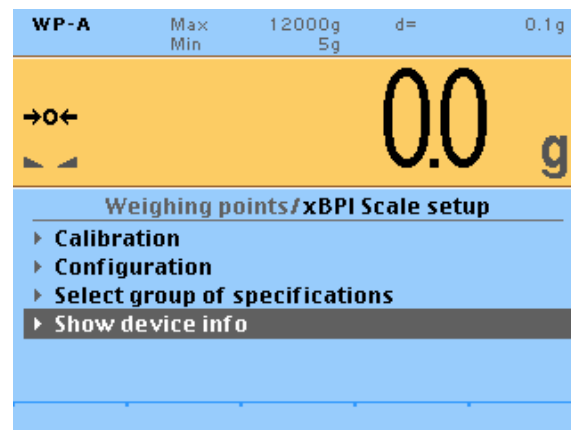

3. Select [Show device info] with the cursor and confirm.

▷ The following window opens:

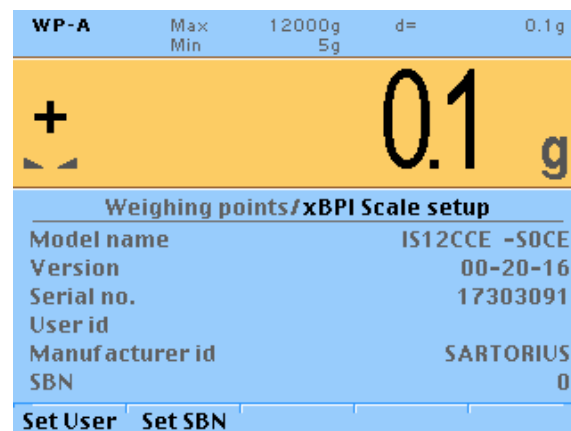

4. Change the user ID and SBN address if necessary.
5. Press the  softkey to exit the menu and to save the settings.

6. Select [Select group of specification] using the cursor and confirm.

Note:

Some xBPI platforms have what is known as "specification blocks" for selecting various modes of operation (single range, multiple range, etc.).

The following is required for the subsequent specification group selection:

- Note the model name of the scale.
 - Refer to the operating instructions for the number of the corresponding specification block.
-

7. Select and confirm the desired specification group.
8. Press the  softkey to exit the menu and to save the settings.
 - ▷ A prompt window opens.
9. Press the [Yes] softkey to save the data.

Press [No] for exit from the menu without data change.

 - ▷ The parameters are saved. Ticks indicate the progress.
10. Select [Configuration] using the cursor and confirm.
11. Select [Weighing parameters] with the cursor and confirm.

The parameters are listed as an overview in the following, see Chapter [7.15.5.1](#).

Note:

Only the parameters supported by the connected scale are displayed.

12. Press the  softkey to exit the menu and to save the settings.
 - ▷ A prompt window opens.
13. Press the [Yes] softkey to save the data.

Press [No] for exit from the menu without data change.
14. Select [Application settings] with the cursor and confirm.

The parameters are listed as an overview in the following, see Chapter [7.15.5.2](#).

Note:

Only the parameters supported by the connected scale are displayed.

15. Press the  softkey to exit the menu and to save the settings.
 - ▷ A prompt window opens.
16. Press the [Yes] softkey to save the data.

Press [No] for exit from the menu without data change.
17. Select [Interface settings] with the cursor and confirm.

The parameters are listed as an overview in the following, see Chapter [7.15.5.3](#).

Note:

Only the parameters supported by the connected scale are displayed.

18. Press the  softkey to exit the menu and to save the settings.
 - ▷ A prompt window opens.
19. Press the [Yes] softkey to save the data.
 - Press [No] for exit from the menu without data change.

7.15.5 xBPI-parameter tables

The parameters which must be entered are listed in the following tables under [Weighing point]- [Weighing point A]- [xBPI-Scale]- [Setup]- [Configuration]- [Weighing parameters]/[Application settings]/[Interface settings].

7.15.5.1 Scale parameters

[Weighing parameters]	
—	Ambient conditions
	Very stable cond.
	Stable conditions
	Unstable cond.
	Very unstable cond.
—	Application/Filter
	standard mode
	manual filling
	automatic dosing
	checkweighing
—	Stability range
	0.25 digit
	0.5 digit
	1 digit
	2 digits
	4 digits
	8 digits
—	Stability symb.delay
	no delay
	short delay
	long delay
	extrem long delay
—	Tare parameter
	at any time
	not until stable
—	Auto zero function
	Auto Zero on
	Auto Zero off
—	Adjustment function
	ext.adj.w.fact.wt.
	ext.adj.w.user.wt.

- ext.adj.w.pres.wt.
- internal adjust
- ext.lin.w.fact.wt.
- ext.lin.w.pres.wt.
- Confirm preload
- Delete preload
- adjust disabled
- **Confirming adjust.**
 - automatically
 - manual
- **Zero range**
 - 1% of max load
 - 2% of max load
 - 5% of max load
 - 10% of max load
- **Power-On zero range**
 - factory settings
 - 2% of max load
 - 5% of max load
 - 10% of max load
- **Power-On tare/zero**
 - active
 - inactive
 - only for zeroing
- **Measure rate**
 - normal output
 - fast output
- **Calibration check**
 - Off
 - Calibration prompt
- **External adjustment**
 - Accessible
 - Blocked
- **Maximum capacity**
 - reduced by preload
 - constant

7.15.5.2 Application settings

- **[Application settings]**
- **Application Tare**
 - Accessible
 - Blocked
- **Number of units**
 - 1 weight unit
 - 2 weight units
 - 3 weight units
- **Weight unit 1...3**
 - Grams g
 - Kilogram kg
 - Carat ct
 - Pound lb
 - Ounce oz

—	Troy ounce	ozt
—	Hong Kong tael	tlh
—	Singapore tael	tls
—	Taiwan tael	tlt
—	grain	GN
—	pennyweight	dwt
—	milligram	mg
—	Parts/pound	/lb
—	Tael china	tlc
—	Momme	mom
—	Carat	k
—	Tola	tol
—	Baht	bat
—	Mesghal	m
—	Ton	t
—	Display accuracy 1...3	
—	all digits	
—	reduced when moved	
—	one level lower	
—	two levels lower	
—	three levels lower	
—	1%	
—	0.5%	
—	0.2%	
—	0.1%	
—	0.05%	
—	0.02%	
—	0.01%	
—	Multi interval	
—	increased by 10	

7.15.5.3 Interface parameters

[Interface settings]	
—	Communication type
	SBI protocol
	xBPI protocol
—	Baudrate for SBI
	150 baud
	300 baud
	600 baud
	1200 baud
	2400 baud
	4800 baud
	9600 baud
	19200 baud
—	Parity for SBI
	Mark
	Space
	Odd
	Even
—	Stop bits
	1 stop bit

g
kg
ct
lb

2 stop bits
Handshake
software handshake
CTS with 2 chr.pau
CTS with 1 chr.pau
Data output print
on requ always
on requ when stab
on requ with store
auto
auto when stable
Auto print
start/stop by ESCP
not stoppable
Output format
without ID 16 byte
with ID 22 byte
Data output interval
with each display
after 2 updates
after 5 updates
after 10 updates
after 20 updates
after 50 updates
after 100 updates
Parameter change
can be changed
cannot be changed

7.15.6 Setting the xBPI dead load

Note:

For Minebea Intec both terms "dead load" and "preload" are used.

1. Select -[Weighing point]- [xBPI-Scale] and confirm.

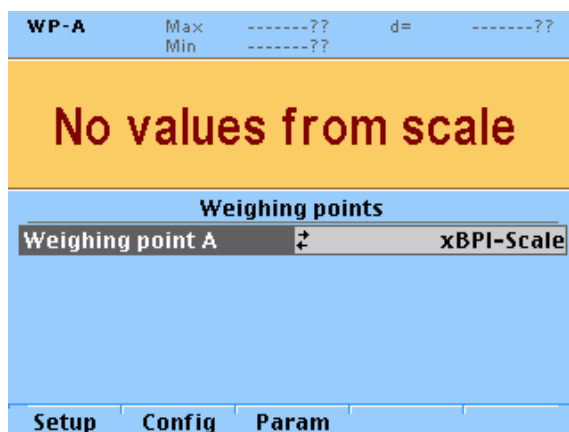

2. Press the [Setup] softkey.

- ▷ The parameters of the xBPI-scale are read into the device.

Ticks indicate the progress.

An error message is displayed if communication with the xBPI scale is not possible!

The following window opens:

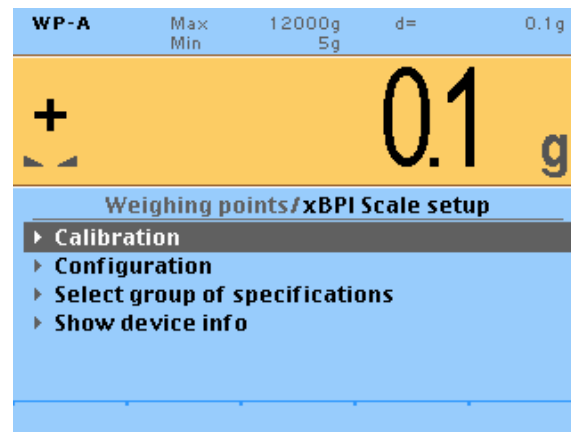

3. Select [Calibration] with the cursor and confirm.

- ▷ The following window opens:

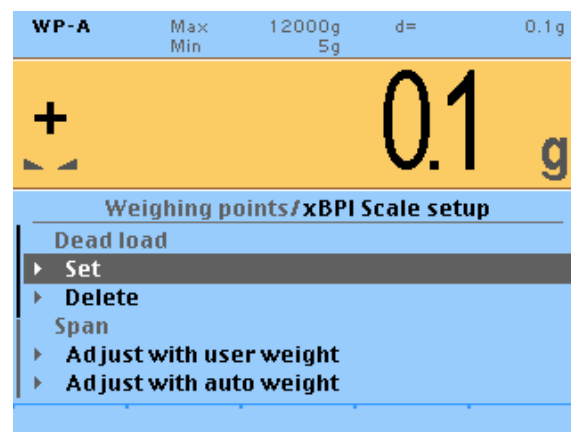

4. For setting the dead load, remove the weight from the scale and select [Set] using the cursor and confirm.

- ▷ After sending the command, 0 is indicated on the gross weight display.

5. Alternatively, the stored dead load can be deleted: Remove the weight from the scale and select [Delete] using the cursor and confirm.

- ▷ The stored dead load is deleted. The current dead load is shown on the weight display.

6. Press the  softkey to exit the menu and to save the settings.

7.15.7 xBPI calibration with user specified weight

Requirements:

- The xBPI protocol has been selected (see Chapter [7.15.2](#)).
- The "xBPI-scale" weighing point has been selected (see Chapter [7.15.3](#)).
- The platform has been set up (see Chapter [7.15.4](#)).

- In the menu [Weighing point A] - [xBPI-Scale] - [Setup] at [Configuration] - [Weighing parameters] - [Confirming adjust.] was set to "manual".
- The communication between the device and platform is active.

Procedure:

1. Select -[Weighing point]- [xBPI-Scale] and confirm.

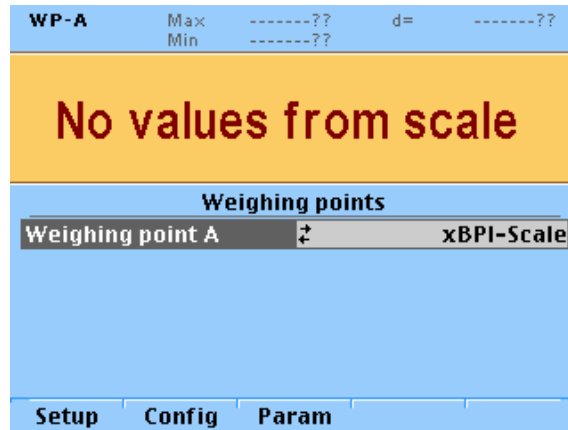

2. Press the [Setup] softkey.
 - ▷ The parameters of the xBPI-scale are read into the device.
3. Select [Calibration]- [Adjust with user weight] and confirm.
 - ▷ An input window appears. The previously stored user weight is displayed.
4. Change the weight value if necessary using the keyboard and confirm.
 - ▷ The calibration process is carried out without a weight. The calibration status is displayed.
5. Place the weight on the scale.
 - ▷ The deviation is displayed in the last line with increased resolution (10-fold).
6. Press the [Accept] softkey.
 - ▷ The data are saved and the instrument returns the following message:

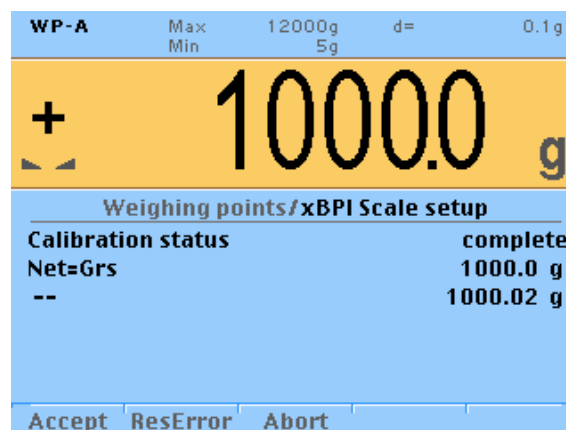

The weight is displayed in high-resolution (10x).

7. Remove the weight.
8. Press the  softkey to exit the menu and to save the settings.

7.15.8 xBPI calibration with automatic weight detection

Requirements:

- The xBPI protocol has been selected (see Chapter 7.15.2).
- The "xBPI-scale" weighing point has been selected (see Chapter 7.15.3).
- The platform has been set up (see Chapter 7.15.4).
- In the menu [Weighing point A] - [xBPI-Scale] - [Setup] at [Configuration] - [Weighing parameters] - [Confirming adjust.] was set to "manual".
- The communication between the device and platform is active.

Procedure:

1. Select -[Weighing point]- [xBPI-Scale] and confirm.

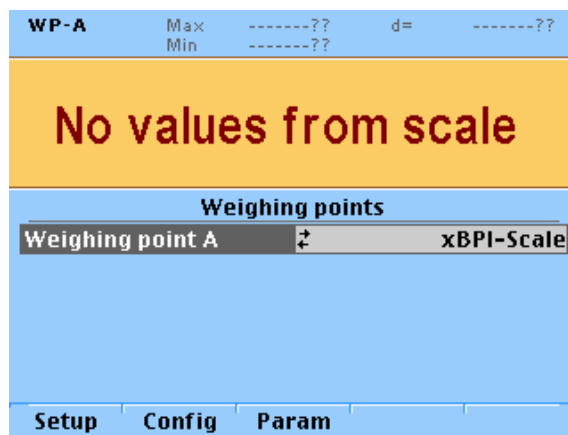

2. Press the [Setup] softkey.
 - ▷ The parameters of the xBPI-scale are read into the device.
3. Select [Calibration]- [Adjust with auto weight] with the cursor and confirm.
 - ▷ The calibration process is carried out without a weight. The calibration status is displayed.

The weight is specified automatically.
4. Place the displayed weight on the scale.
5. Press the [Accept] softkey.
 - ▷ The data are saved.

The weight is displayed in high-resolution (10x).
6. Remove the weight.
7. Press the  softkey to exit the menu and to save the settings.

7.15.9 xBPI calibration with default weight

Requirements:

- The xBPI protocol has been selected (see Chapter 7.15.2).
- The "xBPI-scale" weighing point has been selected (see Chapter 7.15.3).
- The platform has been set up (see Chapter 7.15.4).

- In the menu [Weighing point A] - [xBPI-Scale] - [Setup] at [Configuration] - [Weighing parameters] - [Confirming adjust.] was set to "manual".
- The communication between the device and platform is active.

Procedure:

1. Select -[Weighing point]- [xBPI-Scale] and confirm.

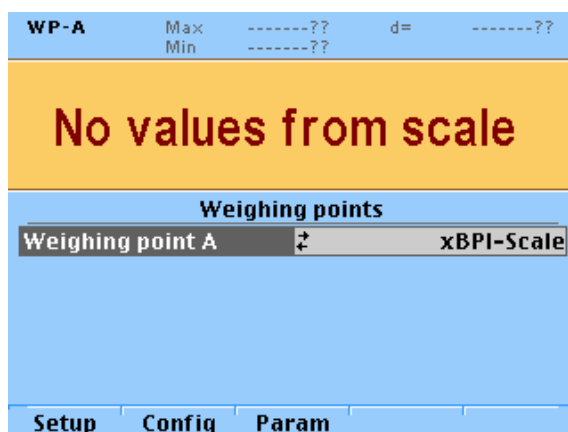

2. Press the [Setup] softkey.
 - ▷ The parameters of the xBPI-scale are read into the device.
3. Select [Calibration]- [Adjust with default weight] with the cursor and confirm.
 - ▷ The calibration process is carried out without a weight. The calibration status is displayed.
The weight is specified automatically.
4. Place the displayed weight on the scale.
 - ▷ The deviation is displayed in the last line with increased resolution (10-fold).
5. Press the [Accept] softkey.
 - ▷ The data are saved.
The weight is displayed in high-resolution (10x).
6. Remove the weight.
7. Press the  softkey to exit the menu and to save the settings.

7.15.10 xBPI calibration with built-in weight**Requirements:**

- The xBPI protocol has been selected (see Chapter [7.15.2](#)).
- The "xBPI-scale" weighing point has been selected (see Chapter [7.15.3](#)).
- The platform has been set up (see Chapter [7.15.4](#)).
- In the menu [Weighing point A] - [xBPI-Scale] - [Setup] at [Configuration] - [Weighing parameters] - [Confirming adjust.] was set to "manual".
- The communication between the device and platform is active.

Procedure:

1. Select -[Weighing point]- [xBPI-Scale] and confirm.

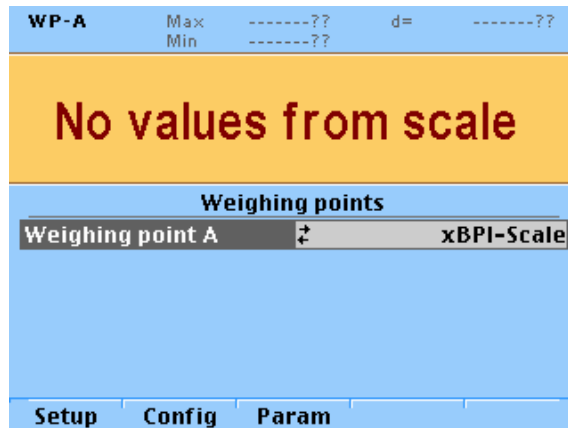

2. Press the [Setup] softkey.
 - ▷ The parameters of the xBPI-scale are read into the device.
3. Select [Calibration]- [Adjust with intern weight] with the cursor and confirm.
 - ▷ The procedure is displayed by status messages in a row.
 - The deviation is displayed in the last line with increased resolution (10-fold).
4. Press the [Accept] softkey.
 - ▷ The data are saved.
 - The weight is displayed in high-resolution (10x).
5. Press the  softkey to exit the menu and to save the settings.

7.15.11 xBPI linearization

The measurement range for a straight can be optimized by setting the linearization points. The following describes standard linearization.

Requirements:

- The xBPI protocol has been selected (see Chapter [7.15.2](#)).
- The "xBPI-scale" weighing point has been selected (see Chapter [7.15.3](#)).
- The platform has been set up (see Chapter [7.15.4](#)).
- In the menu [Weighing point A] - [xBPI-Scale] - [Setup] at [Configuration] - [Weighing parameters] - [Confirming adjust.] was set to "manual".
- The communication between the device and platform is active.

Procedure:

1. Select -[Weighing point]- [xBPI-Scale] and confirm.

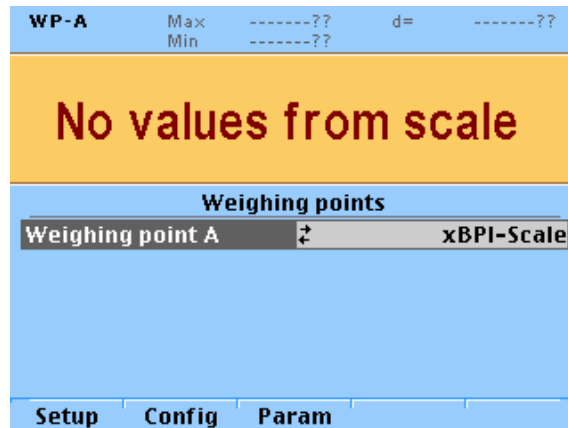

2. Press the [Setup] softkey.
 - ▷ The parameters of the xBPI-scale are read into the device.
3. Select [Calibration]- [Linearity: Default] using the cursor and confirm.
 - ▷ The first linearization point to be calibrated is displayed.
4. Place the displayed weight on the scale.
 - ▷ The deviation is displayed in the last line with increased resolution (10-fold).
5. Press the [Accept] softkey.
 - ▷ The second linearization point to be calibrated is displayed.
6. Place the displayed weight on the scale.
 - ▷ The deviation is displayed in the last line with increased resolution (10-fold).
7. Press the [Accept] softkey.
 - ▷ The third linearization point to be calibrated is displayed.
8. Place the displayed weight on the scale.
 - ▷ The deviation is displayed in the last line with increased resolution (10-fold).
9. Press the [Accept] softkey.
 - ▷ The last linearization point to be calibrated is displayed.
10. Place the displayed weight on the scale.
 - ▷ The deviation is displayed in the last line with increased resolution (10-fold).
11. Press the [Accept] softkey.
12. Press the  softkey to exit the menu and to save the settings.

7.16 Calibrating digital load cells of type "Pendeo"

7.16.1 General information

The digital load cells have been calibrated at the factory based on the acceleration of gravity at Hamburg (9.81379 m/s^2). The calibration data in the load cells are invariable. The calibration data for the gravity acceleration at the place of installation can be adapted only in the instrument and protected against overwriting (see Chapter [7.1.3.1](#)).

With legal-for-trade applications, the legal requirements and the conditions given on the test/approval certificate must be taken into account when selecting the settings.

For connecting digital load cells (xBPI load cells), firmware version 2.10 or higher must be installed.

The available interfaces are visible under -[Show HW-slots].

7.16.2 Selecting and configuring RS-485 interface

Note:

The PR 5510/04 interface card must be installed in the device (see Chapter [4.7](#)).

1. Select -[Serial ports parameter]- [xBPI-Port] and confirm.
 - ▷ The following window opens:

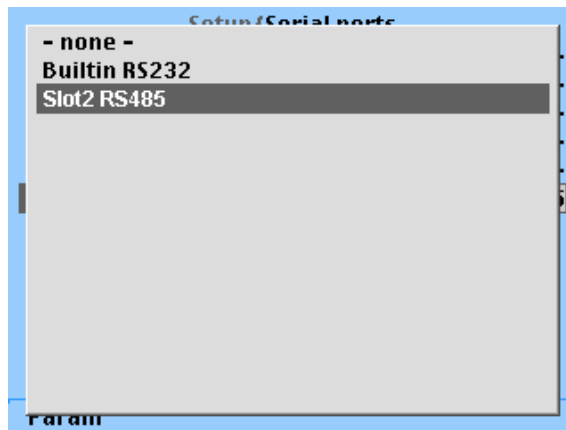

2. Select the desired interface and confirm.

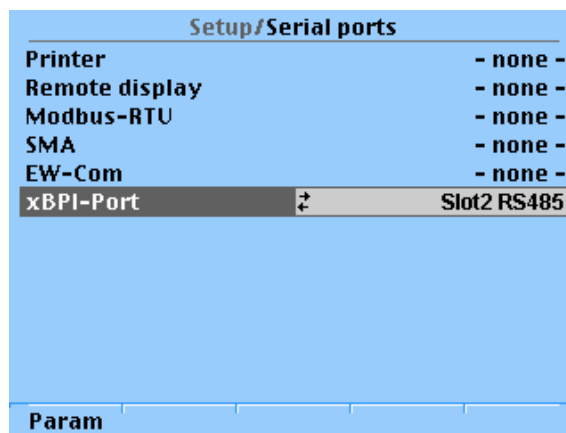

3. Press the [Param] softkey.
 - ▷ The following window opens:

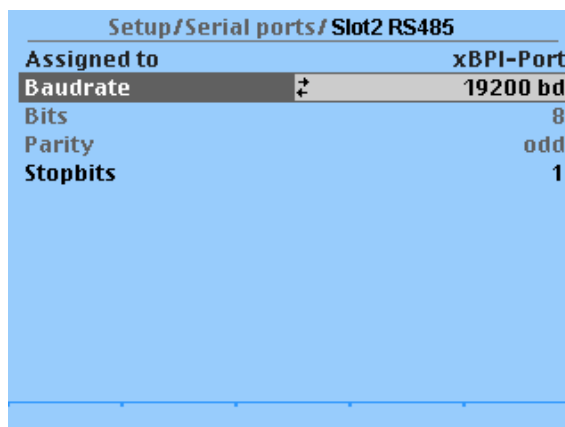

4. Select [Baudrate] and confirm.
 - ▷ A selection window opens.
5. Select "19200 bd" and confirm.
6. Select [Stopbits] and confirm.
 - ▷ A selection window opens.
7. Select "1" and confirm.
8. Press  to exit the menu and to save the settings.

7.16.3 Selecting the load cell type

1. Select -[Weighing point]- [Weighing point A].
 - ▷ A selection window opens.
2. Select "Pendeo Load Cells" and confirm.

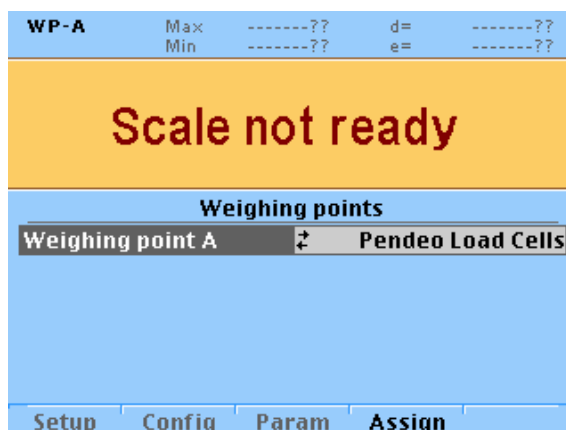

3. Press  to exit the menu and save.

7.16.4 Calibration procedure

During calibration, no data is changed in the digital load cells. The calibration data and parameters are saved in the instrument. The unique serial numbers of the connected load cells are monitored.

For the calibration the following order must be followed:

- Search for load cells, see Chapter [7.16.5](#).
- Assign load cells, see Chapter [7.16.6](#).

- Recalibrate: Maximal load with weight unit, scale interval, dead load, CAL weight, see Chapter [7.16.7](#).
- Perform a corner correction if necessary; see Chapter [7.16.10.3](#).

Note:

For further information about calibrating weighing points, see Chapter [7.14.3](#).

7.16.5 Searching load cells

1. Select -[Weighing point]- [Weighing point A].

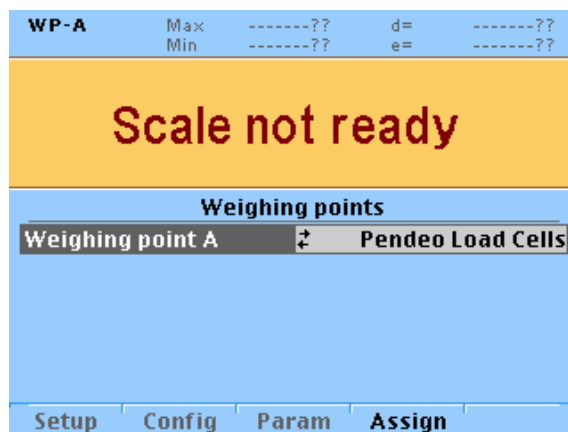

2. Press the [Assign] softkey.
 - ▷ The following window opens:

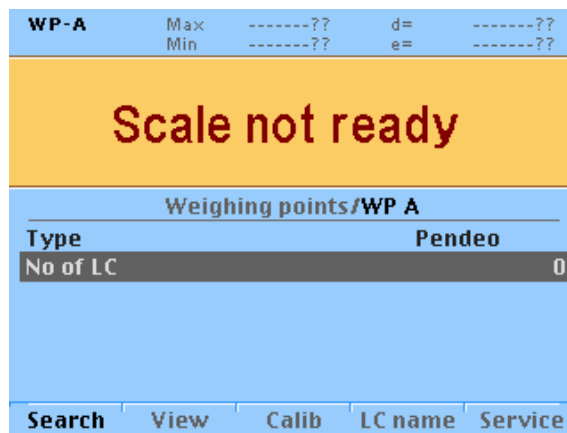

3. Press the [Search] softkey.

- ▷ A prompt window opens.



4. Press the [Continue] softkey to start a new search process.
Press the [Cancel] softkey to accept and display the existing values.

- ▷ A window with load cell information opens

[Type]

Type of load cells

[No of LC]

Number of load cells

[LC 1...n]

Serial number/name of the load cells

[WP serial number]

Weighing point serial number(is displayed after search)

5. Press the [View] softkey.
 - ▷ The load cells are displayed with their item number, serial number, and load.
6. Select the desired load cell and press the [Info] softkey.
 - ▷ The load cell data is displayed.

Note:

If load cell names have been assigned (see Chapter [7.16.8](#)), the view can be switched with the [by name] softkey.

7. Press  to exit the menu and save.

7.16.6 Assigning load cells

The load cells (serial number) can be assigned to the place of installation in this menu. This is important for correcting the dead load (distribution to the individual load cells), for corner correction and in the event of load cell replacement.

An example of a possible assignment is shown below.

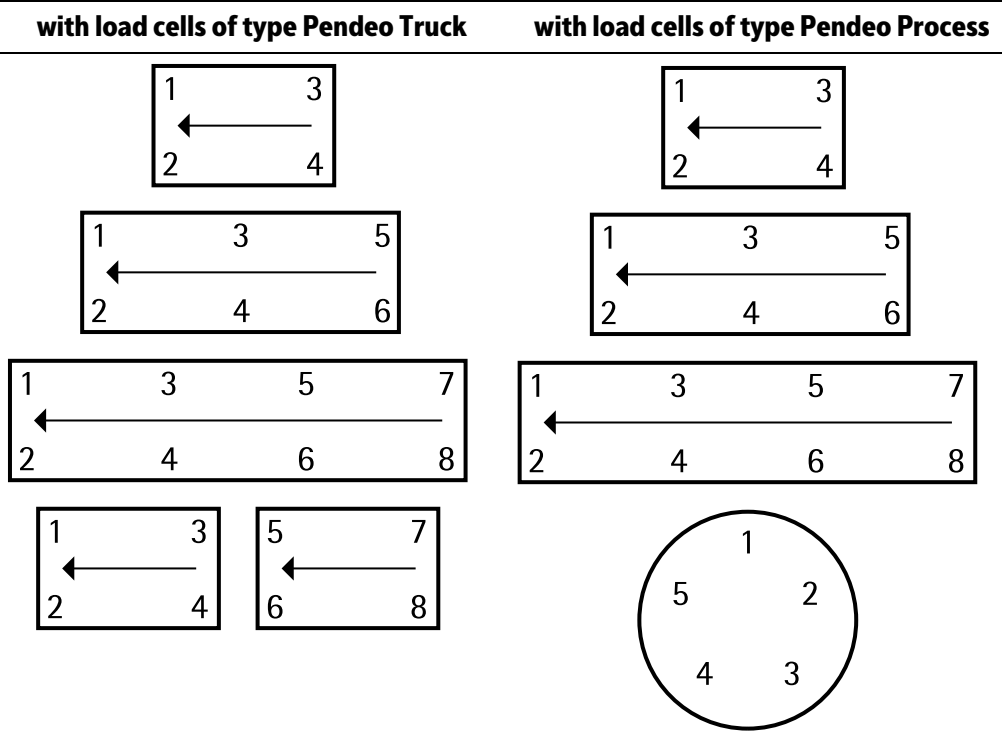

Note:

The assignment from the installation should be documented in the case of load cells being replaced.



The menu is accessed via  - [Weighing point] - [Weighing point A] - [Assign] - [View].

1. Unload the scale.
2. Press the [Assign] softkey.
 - ▷ You are prompted to confirm.
3. Press the [Continue] softkey to reset the dead load information and start the assignment procedure.
4. Press the [Cancel] softkey to not start the assignment.
 - The load cells are assigned by placing minimum weights on the scale (approx. 50 kg).
5. Place the weight on the corner/load cell which will be assigned no. 1 later.
 - As soon as the device detects the weight change, the corresponding line is selected.
6. Confirm the assignment of the first load cell by selecting .
 - ▷ The future LC no. is shown at the far right of the line.
7. Remove the weight.

8. Repeat these steps for load cells 2...4.
9. Press the [Accept] softkey.
10. Press the  softkey to exit the menu and save.
11. Press the [View] softkey.
 - ▷ The new assignment will be displayed.
12. Check the corner load (dead load); see Chapter [7.16.10.1](#).
13. Press the  softkey to exit the menu and save.

7.16.7 Calibrating load cells

The menu is accessed via  - [Weighing point] - [Weighing point A] - [Assign] .

Note:

The [Modify] menu item is only used for small changes (e.g., changing the dead load/preload, changing the mV/V values for dead load/preload and/or Max, changing the scale interval). Otherwise select the [New] menu item.

Example:

Maximum capacity of a load cell: $E_{max} = 50 \text{ t}$

Number of load cells: 4

Max: 200.000 t

Scale interval: 0.020 t

Dead load: Empty weight

CAL weight: 11.000 t

Procedure:

1. Press the [Calib] softkey.
 - ▷ A window opens.
 - For Max the sum of the maximum capacities for load cell are factory settings:
 $4 \times 50 \text{ t} = 200 \text{ t}$
2. Press the [New] softkey.
 - ▷ The data is set to factory settings (default) first before calibration is started.
 - A prompt window opens.
3. Press the [Yes] softkey to reset the corner correction and the calibration to continue.
 - ▷ The "Calibration window" opens.
4. Entering and verifying parameters.

[Local gravity]

Entering the local value of gravitational acceleration (in this example: Hamburg 9.81379 m/s^2), see e.g. <http://www.ptb.de/cartoweb3/SISproject.php>.

[Number of platforms] (only for Pendeo Truck-load cell)

This parameter is shown only in the case of 8 load cells.

Entering the number of platforms.

[Number of vessel feet] (only for Pendeo Process-load cells)

Enter the number of vessel feet.

Note:

The number of vessel feet and the number of load cells may differ, e.g.: 4 vessel feet on 1 pivots and 3 load cells.

[Max]

The load cell capacity is suggested as Max ($E_{\max} \times$ number of load cells).

The maximum load (Max) determines the maximum measured weight without dead load. Normally, the selected Max must be smaller than the load cell capacity (maximum capacity \times number of load cells) – dead load, in order to prevent overloading the load cells.

Enter the maximum load with decimal places (in this example: 200.000 t).

The  key can be pressed to switch between units.

[Scale interval]

Selecting the scale interval (1 d) (in this example: 0020).

The scale interval (d) is calculated, based on the maximum weight value.

[Dead load]

To use the empty scale as dead load (normal case):

- Do not load scale.
- Press the [by load] softkey.

Note:

If the dead load is known, the value can be overwritten [by value].

[CAL weight]

- Center the CAL weight on the scale and enter the weight value with decimal places (here: 11.000 t).
- Press the [Ok] softkey and remove CAL weight.

[Corner correction]

Perform a corner correction if necessary; see Chapter [7.16.10.3](#).

Note:

During calibration the weight can be displayed with 10 fold resolution by pressing the  key.

After 5 seconds the display returns to normal resolution. Press  if you want to switch to normal resolution immediately.

- Press the  softkey to exit the menu.

7.16.8 Assigning load cell names

In this menu the load cells can also be assigned names in addition to the load cell no. and serial numbers.

The menu is accessible via  - [Weighing point] - [Weighing point A] - [Assign] - [LC name] .

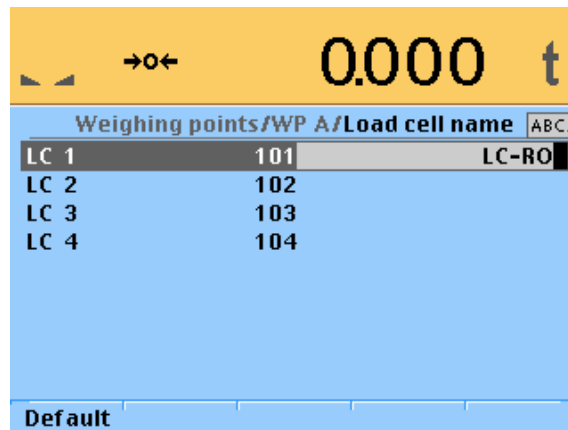

Weighing points/WP A/Load cell name		
LC 1	101	LC-RO
LC 2	102	
LC 3	103	
LC 4	104	

- Select the line, enter the name with the keyboard (max. 20 alphanumerical characters) and confirm.
- Repeat these steps for load cells 2...4.
- Press  to exit the menu and save.

7.16.9 Service function

In this menu faulty load cells can be deactivated and replaced load cells activated.

The menu is accessible via  - [Weighing point] - [Weighing point A] - [Assign] - [Service].
The service window appears.

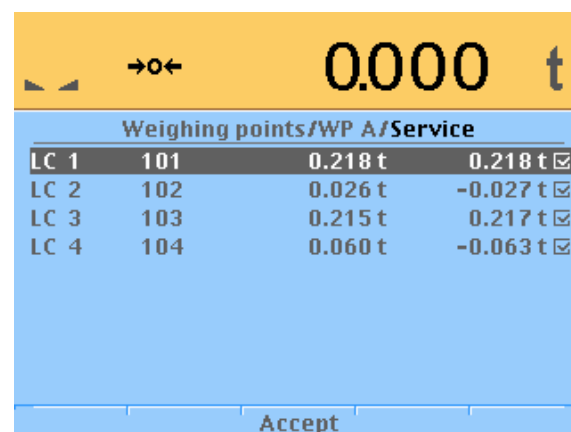

Weighing points/WP A/Service			
LC 1	101	0.218 t	<input checked="" type="checkbox"/>
LC 2	102	0.026 t	<input checked="" type="checkbox"/>
LC 3	103	0.215 t	<input checked="" type="checkbox"/>
LC 4	104	0.060 t	<input checked="" type="checkbox"/>

Item number, serial number, dead load and current weigh of connected load cells are displayed.

7.16.9.1 Deactivating the load cell

A load cell can be deactivated if it is defective. The weight is then distributed to the remaining load cells.

Note:

For vehicle weighbridges:

Trucks should only be allowed to move onto the center of the weighing platform, in order to distribute the weight evenly.

1. Select the faulty load cell and confirm, to deactivate the cell.

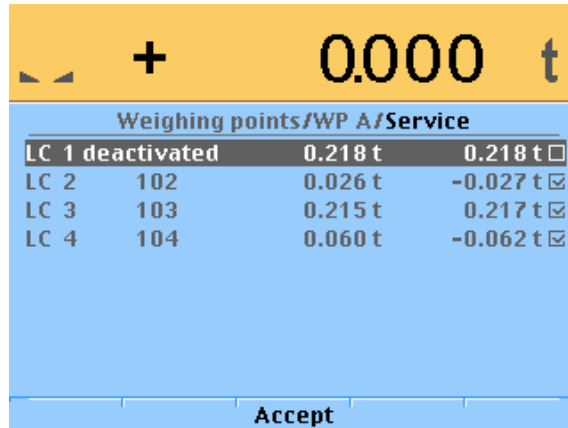

The screenshot shows a weighing interface with a yellow header bar containing a plus sign and the weight '0.000 t'. Below the header is a table titled 'Weighing points/WP A/Service'. The table has four rows: 'LC 1 deactivated', 'LC 2 102', 'LC 3 103', and 'LC 4 104'. Each row shows two weight values and a checkbox. The 'LC 1 deactivated' row has a checkbox that is not checked. The other rows have checked checkboxes. At the bottom of the screen is an 'Accept' softkey.

Weighing points/WP A/Service			
LC 1 deactivated		0.218 t	0.218 t <input type="checkbox"/>
LC 2	102	0.026 t	-0.027 t <input checked="" type="checkbox"/>
LC 3	103	0.215 t	0.217 t <input checked="" type="checkbox"/>
LC 4	104	0.060 t	-0.062 t <input checked="" type="checkbox"/>

2. Press the [Accept] softkey.
 - ▷ The warning symbol replaces the weight unit.

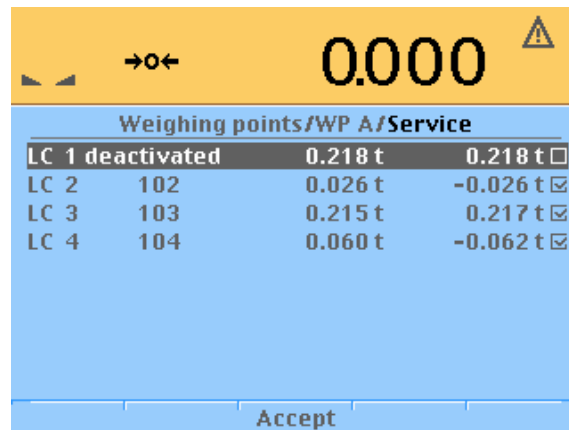

The screenshot shows the same weighing interface as the previous one, but now a warning symbol (a triangle with an exclamation mark) is visible in the top right corner of the yellow header bar, replacing the weight unit. The table and 'Accept' softkey remain the same.

7.16.9.2 Activating the load cell

1. After inserting and connecting the new load cell, select the line of the deactivated load cell and confirm.
2. Press the [Accept] softkey.
 - ▷ A search process is started and only then is the new load cell detected.

7.16.10 Corner correction

7.16.10.1 Checking the corner load (dead load)

Note:

For scale structures with containers pay attention to the following:

- For asymmetric scale structures a corner correction is not necessary.
 - But for symmetric scale structures corner correction may be required.
-

After assignment and calibration, the load cell positions have been defined clearly.

7.16.10.2 Mechanical corner correction

A Mechanical corner correction has to be carried out, if the load is not evenly distributed over the load cells, e.g. if the platform is wobbling.

The dead load on the load cells can be corrected using shims. If two coupled platforms are connected, corner load checking or installation of shims for the platforms must be performed independently.

A fine calibration can be done by software corner correction, see Chapter [7.16.10.3](#).

7.16.10.3 Software corner correction

If the corners are loaded in succession, the same value should be displayed on the device at all times. An excessive deviation almost always means that the scale is tilted or indicates load cell force shunts.

If the signal deviations cannot be resolved by carefully leveling the scale, the software must be calibrated.

The menu is accessible via -[Weighing point]- [Weighing point A]- [Assign].

1. Press the [Modify] softkey.
2. Select and confirm [Corner correction].
3. Set the CAL weight on an area of the scale structure.
 - ▷ The position (e.g.: LC 4) is highlighted.
4. Confirm this position.
 - ▷ Is displayed by .
5. Remove the CAL weight.
6. Repeat steps 3 to 5 for the remaining load cells. You are free to choose any desired order.
7. If all load cells have been loaded one time, press the [Calc] softkey to perform the corner correction.
 - ▷ The total weight remains unchanged. Only the effect of the individual load cells is corrected.

When corner correction is completed, it is marked with "OK".

8. Press  to exit the menu and save.

7.16.11 Terminating/saving calibration

The calibration is terminated by pressing the  key.

Unless all data were determined during recalibration using [New] (e.g. dead load not set/entered), the following prompt is displayed:

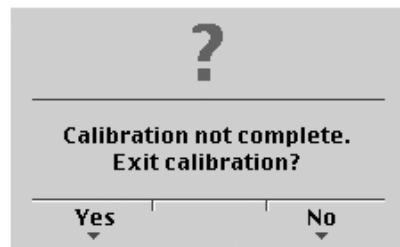

1. Press the [Yes] softkey to exit the calibration.
2. Confirm .
 - ▷ A prompt window opens.

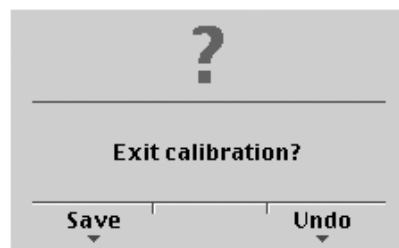

3. Press the [Save] softkey to save changes in calibration data.
 - ▷ The verification is displayed by "Saving calibration".
4. Press the [Undo] softkey if you do not want to save the changes.
 - ▷ The scale returns to the selection menu.
 - Leaving the menu is displayed by "Exit calibration".
5. After finishing calibration, set the CAL switch to the closed position; see Chapter [7.1.3.1](#).

7.16.12 Parameter Input

The menu is accessible via  - [Weighing point] - [Weighing point A] - [Assign] - [Calib] - [Param].

WP-A	Max	20t	d=	0.02t
	Min	0.4t		
→← 0.000 t				
Weighing points/WP A/Calibration				
Ambient conditions	↕	Very stable cond.		
W & M		none		
Unbal. check deviat.		0 %		
Standstill time		0.50 s		
Standstill range		1.00 d		
Tare timeout		2.5 s		

[Ambient conditions]

This parameter is used to define the ambient conditions of the scale.

Possible Selections: very stable condition, stable condition, unstable condition, very unstable condition

[W&M]

See Chapter [7.14.15.1](#).

If [OIML] was selected, the device needs to warm up for 30 seconds.

[Unbal. Check deviat.]

The plausibility check is activated when the average deviation is >0%. The average deviation of the individual load cells is calculated.

Setting range: 0...100%.

[Standstill time]

The parameters [Standstill time] and [Standstill range] are used to define the stability of the scale (stable balance).

The input for the parameter [Standstill time] is expressed in seconds.

Valid range: 0.00...2 s

If the time is set to "0" there is no check. The standstill time must not be less than the measuring time.

[Standstill range]

As long as the weight fluctuations remain within this range, the device is determined to be stable.

The input for the parameter [Standstill range] is expressed in "d."

Valid range: 0.01...10.00 dc.

[Tare timeout]

Timeout for a tare/zero command that cannot be executed (e.g. due to mechanical instability of the scale, incorrect filter setting, resolution too high, standstill condition too strict).

The input is done as seconds.

Valid range: 0.0...<2.5>...25 s.

At 0.0 s taring is only carried out when the scale is already stable.

[Zero set range]

Define a \pm range around the zero point determined by the dead load during calibration; within this range

- the displayed gross weight can be set to zero by pressing the zero-setting key (or by a corresponding external command), and
- automatic zero tracking is active.

Setting range: 0.00...10000.00 d

For use in legal metrology a value $\leq 2\%$ of the Max must be entered, example: 60 d for 3000 e of class III.

[Zero track indic. range]

Indication range within which automatic zero tracking compensates deviations.

Setting range: 0.25...10000.00 d

In "legal-for-trade" mode a value of <0.5 d has to be entered.

[Zerotrack step]

If a weight change exceeds the adjusted value, automatic tracking does not function any more.

Setting range for automatic tracking increments: 0.25...10 d

In "legal-for-trade" mode a value of ≤ 0.5 d has to be entered.

[Zerotrack time]

Time interval for automatic zero tracking.

Setting range: 0.1...25 s

At 0.0 s the zero tracking is switched off.

For use in legal metrology a value of 1 s must be entered.

[Overload]

Weighing range above the maximum load (Max) without error message.

Setting range: 0...9999999 d

For use in legal metrology a value of max. 9 d = e must be set.

[Minimum weight]

Minimum weight at which a print command can be triggered.

Setting range: 0...9999999 d

For use in legal metrology a value of at least 20 d must be set.

[Range mode]

Selection: <Single range>, Multiple range, Multi-interval

For scale range selection, see Chapter [7.14.15.2](#) and [7.14.15.3](#).

Press  to exit the menu and to save the settings.

7.16.13 Subsequent dead load correction

If the hopper/platform weight changes by an amount that is higher than the zero-setting range; e.g. due to dead load reduction, dead load increase, or mechanical changes, the functions for automatic zero tracking and manual zero setting no longer work.

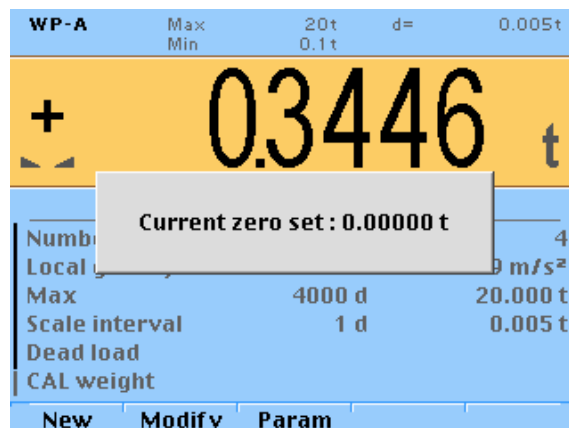

To view the range which is already utilized by zero tracking or zero setting, in [Calibration] press the  key; this also activates 10-fold increased resolution of the weight value.

Press  again to return to the previous state.

Note:

The scale must not be loaded!

If the entire zero-setting range is already utilized, you can still correct the dead load subsequently without affecting other calibration data/parameters. To do this open calibration via -[Weighing point]- [Weighing point A]- [Assign]- [Calib]- [Modify] and determine the dead load with [Dead load] using the [by load] option (see Chapter [7.16.7](#)).

7.16.14 Displaying weighing point serial number

After searching via -[Weighing point]- [Weighing point A]- [Assign]- [Search] the corresponding weighing point serial number is displayed.

7.17 Calibrate load cells incl. Connexx module**7.17.1 General notes**

The Connexx module load cells have been calibrated at the factory based on the acceleration of gravity at Hamburg (9.81379 m/s^2). The calibration data are invariable. The calibration data for the gravity acceleration at the place of installation can be adapted only in the device and protected against overwriting (see Chapter [7.1.3.1](#)).

With legal-for-trade applications, the legal requirements and the conditions given on the test/approval certificate must be taken into account when selecting the settings.

The available interfaces are visible under -[Show HW-slots].

7.17.2 Selecting the load cell type

1. Select -[Weighing point] - [Weighing point A].
▷ A selection window opens.
2. Select "Connexx Load Cells" and confirm.

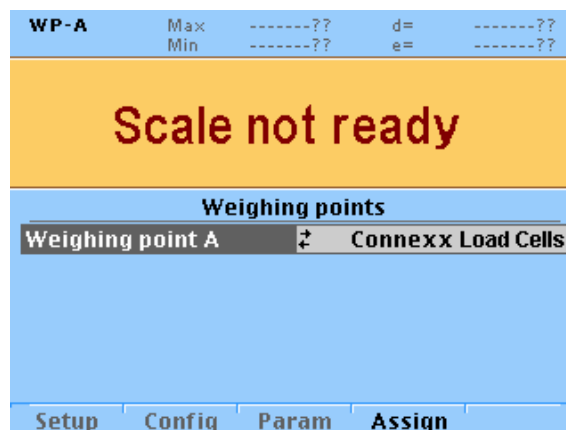

3. Press  to exit the menu and save.

7.17.3 Calibration procedure

During calibration, no data is changed in the Connexx module. The calibration data and parameters are saved in the device. The unique serial numbers of the connected load cells are monitored.

For the calibration the following order must be followed:

- Search for load cells, see Chapter [7.17.4](#).
- Assign load cells, see Chapter [7.17.5](#).
- Recalibrate: Maximum capacity with weight unit, scale interval, dead load, calibration weight, see Chapter [7.17.6](#).
- Perform a corner correction if necessary; see Chapter [7.16.10.3](#).

Note:

For further information about calibrating weighing points, see Chapter [7.14.3](#).

7.17.4 Search for load cells

1. Select  - [Weighing point] - [Weighing point A].

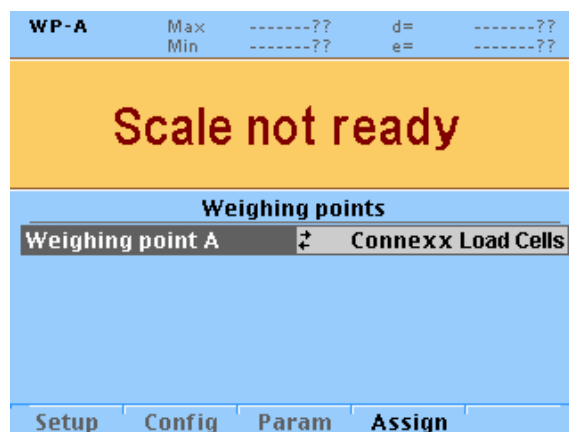

2. Press the [Assign] softkey.
 - ▷ The following window opens:

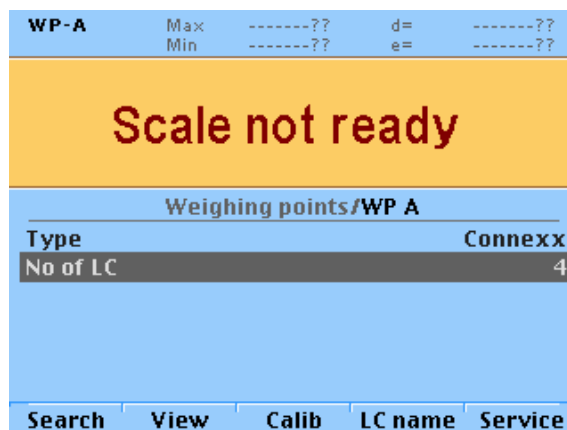

3. Press the [Search] softkey.

- ▷ A prompt window opens.

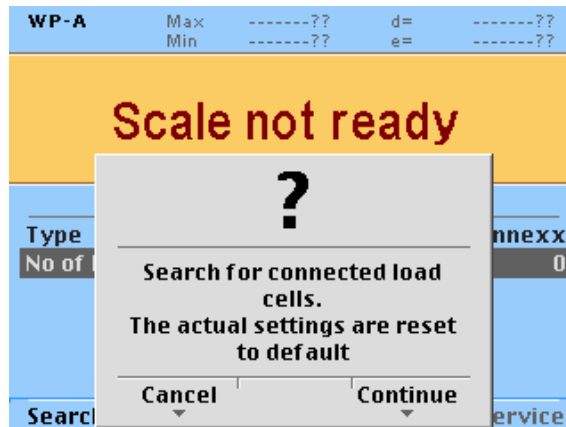

4. Press the [Continue] softkey to start a new search process.
Press the [Cancel] softkey to accept and display the existing values.

- ▷ A window with load cell information opens

[Type]

Type of load cells

[No of LC]

Number of load cells

[LC 1...n]

Serial number/name of the load cells

[WP serial number]

Weighing point serial number(is displayed after search)

5. Press the [View] softkey.
 - ▷ The load cells are displayed with their item number, serial number, and load.
6. Select the desired load cell and press the [Info] softkey.
 - ▷ The load cell data is displayed.

Note:

If load cell names have been assigned (see Chapter [7.17.7](#)), the view can be switched with the [by name] softkey.

7. Press  to exit the menu and save.

7.17.5 Assign load cells

The load cells (serial number) can be assigned to the place of installation in this menu. This is important for correcting the dead load (distribution to the individual load cells), for corner correction and in the event of load cell replacement.

An example of a possible assignment is shown below.

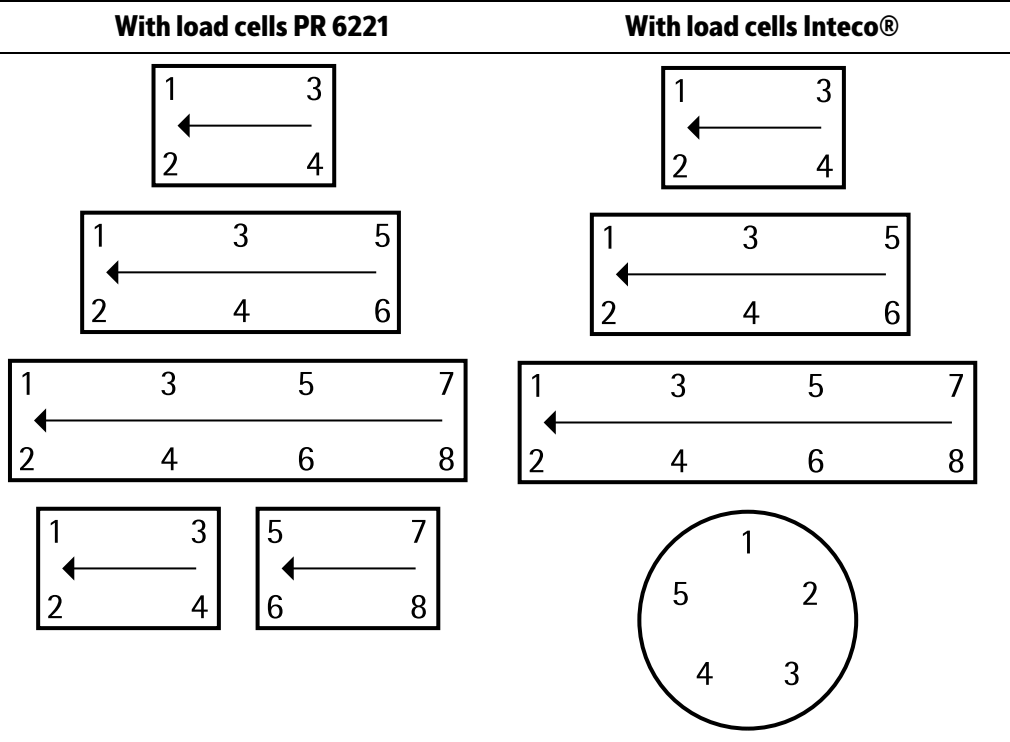

Note:

The assignment from the installation should be documented in the case of load cells being replaced.



The menu is accessed via  - [Weighing point] - [Weighing point A] - [Assign] - [View].

1. Unload the scale.
2. Press the [Assign] softkey.
 - ▷ You are prompted to confirm.
3. Press the [Continue] softkey to reset the dead load information and start the assignment procedure.
4. Press the [Cancel] softkey to not start the assignment.
 - The load cells are assigned by placing minimum weights on the scale (approx. 50 kg).
5. Place the weight on the corner/load cell which will be assigned no. 1 later.
 - As soon as the device detects the weight change, the corresponding line is selected.
6. Confirm the assignment of the first load cell by selecting .
 - ▷ The future LC no. is shown at the far right of the line.
7. Remove the weight.

8. Repeat these steps for load cells 2...4.
9. Press the [Accept] softkey.
10. Press the  softkey to exit the menu and save.
11. Press the [View] softkey.
 - ▷ The new assignment will be displayed.
12. Check the corner load (dead load); see Chapter [7.16.10.1](#).
13. Press the  softkey to exit the menu and save.

7.17.6 Calibrate load cells

The menu is accessed via  - [Weighing point] - [Weighing point A] - [Assign] .

Note:

The [Modify] menu item is only used for small changes (e.g., changing the dead load/preload, changing the mV/V values for dead load/preload and/or Max, changing the scale interval). Otherwise select the [New] menu item.

Example:

Maximum capacity of a load cell: $E_{\max} = 50 \text{ t}$

Number of load cells: 4

Max: 200.000 t

Scale interval: 0.020 t

Dead load: Empty weight

Calibration weight: 11.000 t

Procedure:

1. Press the [Calib] softkey.
 - ▷ A window opens.
 - For Max, the sum of the load cell maximum capacities is pre-set.
 - $4 \times 50 \text{ t} = 200 \text{ t}$
2. Press the [New] softkey.
 - ▷ The data is set to factory settings (default) first before calibration is started.
 - A prompt window opens.
3. Press the [Yes] softkey to reset the corner correction and the calibration to continue.
 - ▷ The "Calibration window" opens.
4. Enter and verify parameters.

[Local gravity]

Enter the local value of gravitational acceleration (in this example: Hamburg 9.81379 m/s^2); see e.g. <http://www.ptb.de/cartoweb3/SISproject.php>.

[Number of platforms] (only for load cells PR 6221)

This parameter is shown only in the case of 8 load cells.

Enter the number of platforms.

[Number of vessel feet] (only for load cells Inteco®)

Enter the number of vessel feet.

Note:

The number of vessel feet and the number of load cells may differ, e.g.: 4 vessel feet on 1 pivot and 3 load cells.

[Max]

The load cell capacity is suggested as Max ($E_{\max} \times$ number of load cells).

The maximum load (Max) determines the maximum measured weight without dead load. Normally, the selected Max must be smaller than the load cell capacity (maximum capacity \times number of load cells) – dead load, in order to prevent overloading the load cells.

Enter the maximum capacity with decimal places (in this example: 200.000 t).

The  key can be pressed to switch between units.

[Scale interval]

Select the scale interval (1 d) (here: 0.020).

The scale interval (d) is calculated, based on the maximum weight value.

[Dead load]

To use the empty checkweigher as dead load (normal case):

- Do not load scale.
 - Press the [by load] softkey.
-

Note:

Once the dead load is known, the value can be overwritten by [by value].

[CAL weight]

- Center the CAL weight on the scale and enter the weight value with decimal places (here: 11.000 t).
- Press the [Ok] softkey and remove CAL weight.

[Corner correction]

Perform a corner correction if necessary; see Chapter [7.16.10.3](#).

Note:

During calibration the weight can be displayed with 10 fold resolution by pressing the  key.

After 5 seconds the display returns to normal resolution. Press  if you want to switch to normal resolution immediately.

- Press the  softkey to exit the menu.

7.17.7 Assign load cell name

In this menu the load cells can also be assigned names in addition to the load cell no. and serial numbers.

The menu is accessible via -[Weighing point]- [Weighing point A]- [Assign]- [LC name].

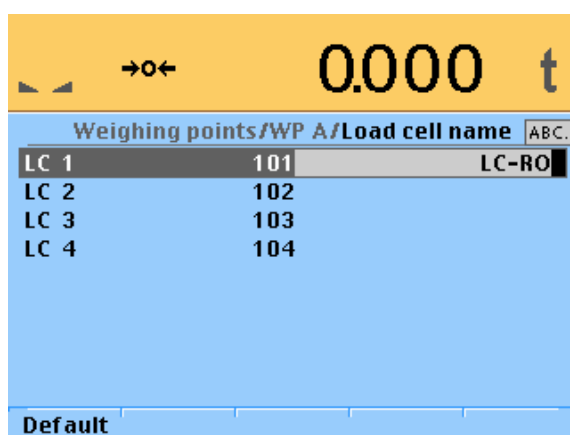

Weighing points/WP A/Load cell name		
LC 1	101	LC-RO
LC 2	102	
LC 3	103	
LC 4	104	

Default

- Select the line, enter the name with the keyboard (max. 20 alphanumerical characters) and confirm.
- Repeat these steps for load cells 2 to 4.
- Press  to exit the menu and save.

7.17.8 Service function

In this menu faulty load cells can be deactivated and replaced load cells activated.

The menu is accessible via -[Weighing point]- [Weighing point A]- [Assign]- [Service].
The service window appears.

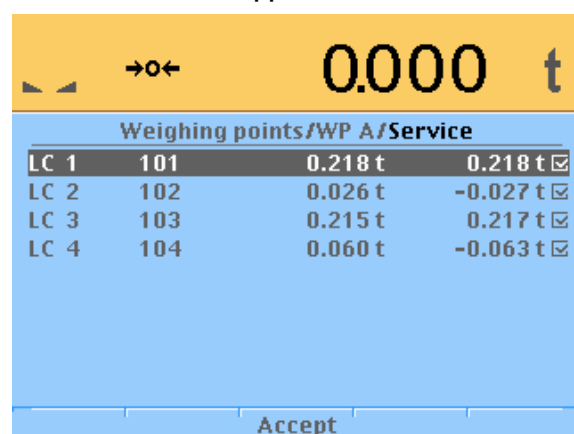

Weighing points/WP A/Service			
LC 1	101	0.218 t	<input checked="" type="checkbox"/>
LC 2	102	0.026 t	<input checked="" type="checkbox"/>
LC 3	103	0.215 t	<input checked="" type="checkbox"/>
LC 4	104	0.060 t	<input checked="" type="checkbox"/>

Accept

Item number, serial number, dead load and current weigh of connected load cells are displayed.

7.17.8.1 Deactivating the load cell

A load cell can be deactivated if it is defective. The weight is then distributed to the remaining load cells.

Note:

For vehicle weighbridges:

Trucks should only be allowed to move onto the center of the weighing platform, in order to distribute the weight evenly.

1. Select the faulty load cell and confirm, to deactivate the cell.

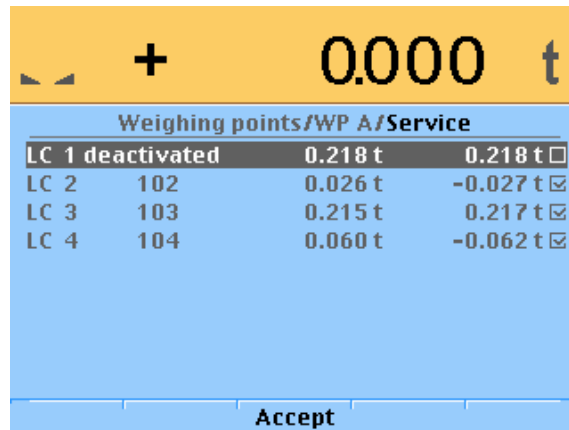

2. Press the [Accept] softkey.
 - ▷ The warning symbol replaces the weight unit.

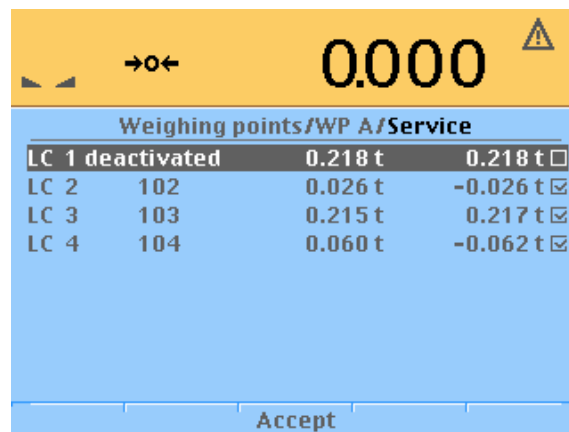

7.17.8.2 Activating the load cell

1. After inserting and connecting the new load cell, select the line of the deactivated load cell and confirm.
2. Press the [Accept] softkey.
 - ▷ A search process is started and only then is the new load cell detected.

7.17.8.3 Service function

In this menu faulty load cells can be deactivated and replaced load cells activated.

The menu is accessible via -[Weighing point]- [Weighing point A]- [Assign]- [Service].
The service window appears.

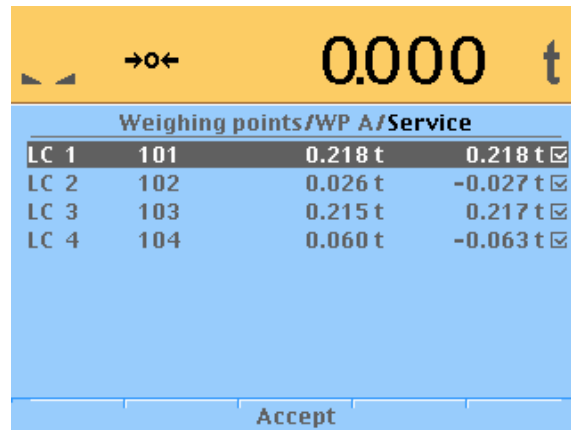

Weighing points/WP A/Service			
LC 1	101	0.218 t	0.218 t <input checked="" type="checkbox"/>
LC 2	102	0.026 t	-0.027 t <input checked="" type="checkbox"/>
LC 3	103	0.215 t	0.217 t <input checked="" type="checkbox"/>
LC 4	104	0.060 t	-0.063 t <input checked="" type="checkbox"/>

Accept

Item number, serial number, dead load and current weigh of connected load cells are displayed.

7.17.9 Corner correction

7.17.9.1 Checking the corner load (dead load)

Note:

For scale structures with containers pay attention to the following:

- For asymmetric scale structures a corner correction is not necessary.
 - But for symmetric scale structures corner correction may be required.
-

After assignment and calibration, the load cell positions have been defined clearly.

7.17.9.2 Mechanical corner correction

A Mechanical corner correction has to be carried out, if the load is not evenly distributed over the load cells, e.g. if the platform is wobbling.

The dead load on the load cells can be corrected using shims. If two coupled platforms are connected, corner load checking or installation of shims for the platforms must be performed independently.

A fine calibration can be done by software corner correction, see Chapter [7.16.10.3](#).

7.17.9.3 Software corner correction

If the corners are loaded in succession, the same value should be displayed on the device at all times. An excessive deviation almost always means that the scale is tilted or indicates load cell force shunts.

If the signal deviations cannot be resolved by carefully leveling the scale, the software must be calibrated.

The menu is accessible via -[Weighing point]- [Weighing point A]- [Assign].

1. Press the [Modify] softkey.
2. Select and confirm [Corner correction].
3. Set the CAL weight on an area of the scale structure.
 - ▷ The position (e.g.: LC 4) is highlighted.
4. Confirm this position.
 - ▷ Is displayed by .

5. Remove the CAL weight.
6. Repeat steps 3 to 5 for the remaining load cells. You are free to choose any desired order.
7. If all load cells have been loaded one time, press the [Calc] softkey to perform the corner correction.
 - ▷ The total weight remains unchanged. Only the effect of the individual load cells is corrected.

When corner correction is completed, it is marked with "OK".
8. Press  to exit the menu and save.

7.17.10 Terminating/saving calibration

The calibration is terminated by pressing the  key.

Unless all data were determined during recalibration using [New] (e.g. dead load not set/entered), the following prompt is displayed:

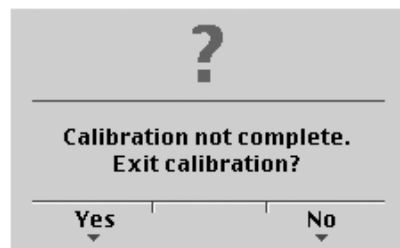

1. Press the [Yes] softkey to exit the calibration.
2. Confirm .
 - ▷ A prompt window opens.

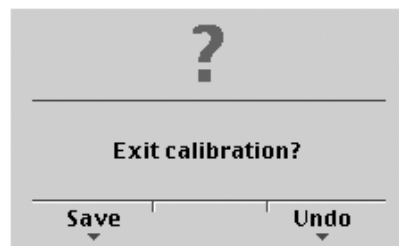

3. Press the [Save] softkey to save changes in calibration data.
 - ▷ The verification is displayed by "Saving calibration".
4. Press the [Undo] softkey if you do not want to save the changes.
 - ▷ The scale returns to the selection menu.

Leaving the menu is displayed by "Exit calibration".
5. After finishing calibration, set the CAL switch to the closed position; see Chapter [7.1.3.1](#).

7.17.11 Parameter input

The menu is accessible via  - [Weighing point] - [Calib] - [Param] .

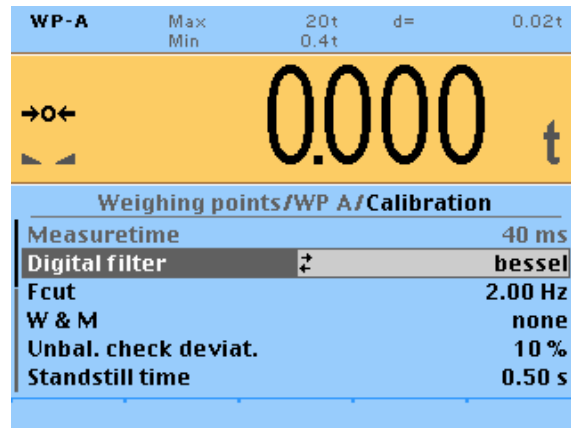

[Measuretime]

Measurement time: The value cannot be changed. It is specified by the Connexx module.

[Digital filter]

Selection of the digital filter (filter characteristic): <off> (no Filter), Bessel, aperiod. (aperiodic), Butterw. (Butterworth), Tcheby. (Tschebyscheff)

The following includes examples of interference signals for the different filter types:

Bessel filter

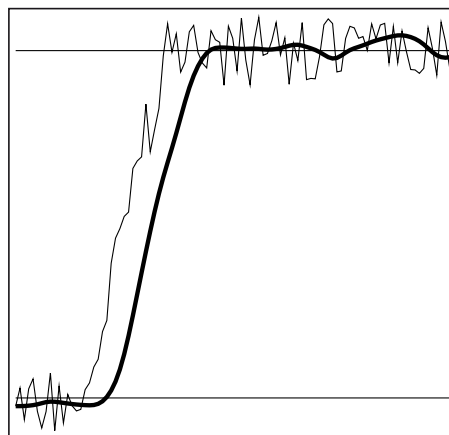

Aperiodic filter

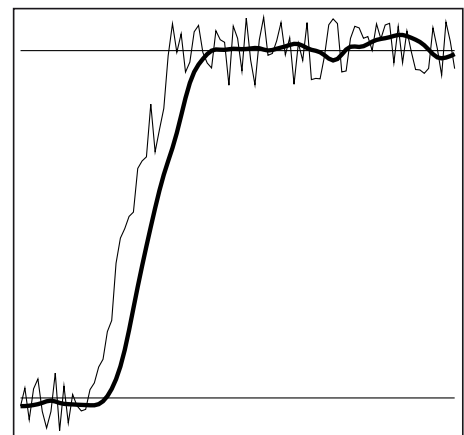

Butterworth filter

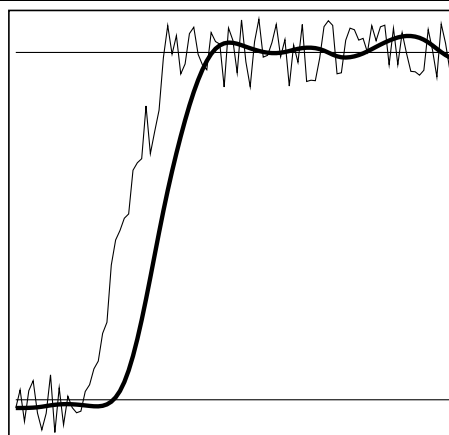

Tschebyscheff filter

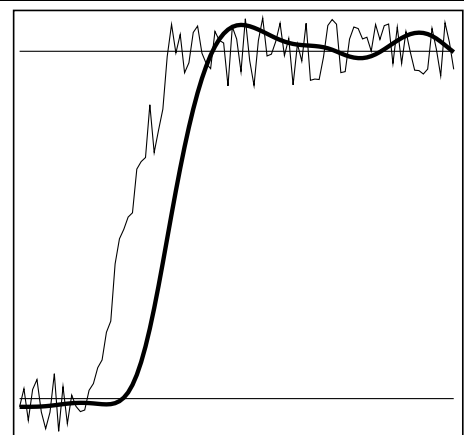

A digital filter can be switched on only with the measuring time set to <160 ms.

If no particularly frequent fluctuations are expected in ongoing operation, the following settings are recommended:

[Measuretime]: <160 ms

[Digital filter]: aperiod.

[Fcut]: 2.00 Hz

[Fcut]

This line only is shown if the digital filter is switched on.

The smaller the cut-off frequency, the slower the measurement and the more stable the measurement result.

The cut-off frequency can be specified for the low pass filter.

Valid range: 0.1...2.5 Hz.

The available options depend on the measuring time.

[W&M]

See Chapter [7.14.15.1](#).

If [OIML] was selected, the device needs to warm up for 30 seconds.

[Unbal. Check deviat.]

The plausibility check is activated when the average deviation is >0%. The average deviation of the individual load cells is calculated.

Setting range: 0...100%.

[Standstill time]

The parameters [Standstill time] and [Standstill range] are used to define the stability of the scale (stable balance).

The input for the parameter [Standstill time] is expressed in seconds.

Valid range: 0.00...2 s

If the tone is set to "0" there is no check. The standstill time must not be less than the measuring time.

[Standstill range]

As long as the weight fluctuations remain within this range, the device is determined to be stable.

The input for the parameter [Standstill range] is expressed in "d."

Valid range: 0.01...10.00 dc.

[Tare timeout]

Timeout for a tare/zero set command that cannot be executed (e.g. due to mechanical instability of the scale, incorrect filter setting, resolution too high, standstill condition too strict).

The input is done as seconds.

Valid range: 0.0...<2.5>...25 s.

At 0.0 s taring is only carried out when the scale is already stable.

[Zeroset range]

Define a \pm range around the zero point determined by the dead load during calibration; within this range

- the displayed gross weight can be set to zero by pressing the zero-setting key (or by a corresponding external command), and
- automatic zero tracking is active.

Setting range: 0.00...10000.00 d

For use in legal metrology a value $\leq 2\%$ of the Max must be entered, example: 60 d for 3000 e of class III.

[Zerotrack indic. range]

Indication range within which automatic zero tracking compensates deviations.

Setting range: 0.25...10000.00 d

In "legal-for-trade" mode a value of < 0.5 d has to be entered.

[Zerotrack step]

If a weight change exceeds the adjusted value, automatic tracking does not function any more.

Setting range for automatic tracking increments: 0.25...10 d

In "legal-for-trade" mode a value of ≤ 0.5 d has to be entered.

[Zerotrack time]

Time interval for automatic zero tracking.

Setting range: 0.1...25 s

At 0.0 s the zero tracking is switched off.

For use in legal metrology a value of 1 s must be entered.

[Overload]

Weighing range above the maximum load (Max) without error message.

Setting range: 0...9999999 d

For use in legal metrology a value of max. 9 d = e must be set.

[Minimum weight]

Minimum weight at which a print command can be triggered.

Setting range: 0...9999999 d

For use in legal metrology a value of at least 20 d must be set.

[Range mode]

Selection: <Single range>, Multiple range, Multi-interval

For scale range selection, see Chapter [7.14.15.2](#) and [7.14.15.3](#).

Press the  softkey to exit the menu and to save the settings.

7.18 General parameter settings

The parameter settings which are not related to the weighing electronics are divided into several ranges.

- Serial interfaces [Serial ports parameter]
- Date and Time [Date & Time]
- Operating parameter [Operating parameter]
- Printing parameter [Printing parameter]

Note:

This menu item is only available if under -[Operating parameter]- [Application] "Standard" has been selected.

- Fieldbus parameter [Fieldbus parameter]
- Network parameter [Network parameter]
- Configuring limits [Limit parameter]

Note:

This menu item is only available if under -[Operating parameter]- [Application] "Standard" has been selected.

- Configuring digital inputs and outputs [Digital i/o parameter]

Note:

This menu item is only available if under -[Operating parameter]- [Application] "Standard" has been selected.

- Configuring analog output [Analog output parameter]

7.18.1 Selecting and configuring serial interfaces

The interfaces are configured under this menu item.

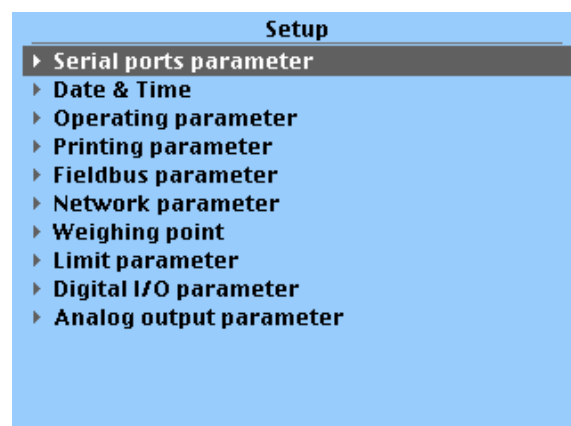

- ▶ Select  - [Serial ports parameter] and confirm.
- ▷ The following window opens.

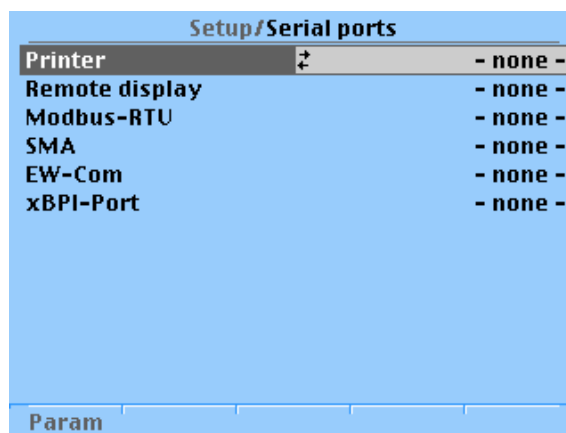

7.18.1.1 Printer protocol

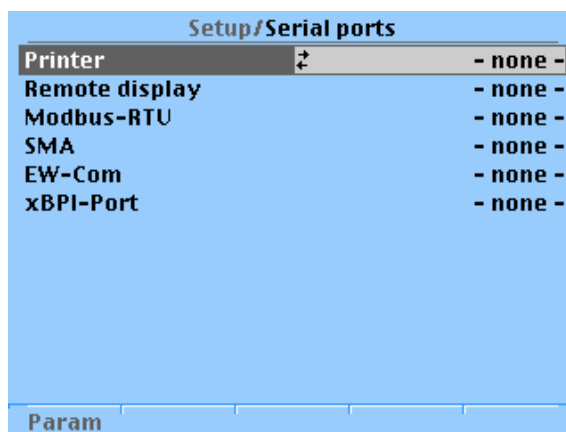

1. Select [Printer] and confirm.
 - ▷ A selection window opens.
2. Select the desired interface and confirm.
 - ▷ The selected interface is displayed.

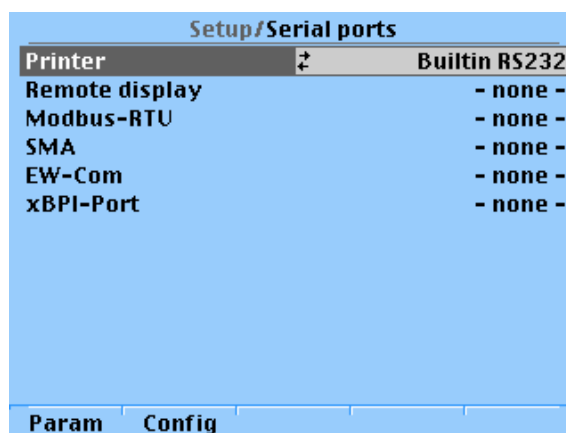

3. Press the [Param] softkey to set the parameters.

- ▷ The following window opens:

Setup/Serial ports/Built-in RS232	
Assigned to	Printer
Protocol ↕	XON/XOFF
Baudrate	9600 bd
Bits	8
Parity	none
Stopbits	1
Output mode	raw

4. Select parameters and confirm.
5. Select and confirm the desired printer settings in the respective selection window.
6. Press  to return to the previous window.
7. Press the [Config] softkey to define the print settings.

- ▷ The following window opens:

Setup/Serial ports/Printing parameter	
Printing mode ↕	Triggered
PrintlayoutItem1	Sequence number
PrintlayoutItem2	Gross weight
PrintlayoutItem3	CR/LF
PrintlayoutItem4	-none-
PrintlayoutItem5	-none-
PrintlayoutItem6	-none-

8. Select parameters and confirm.
9. Select and confirm the desired printer settings in the respective selection window.
10. Press  two times to exit the menu and save.

7.18.1.2 Remote display protocol

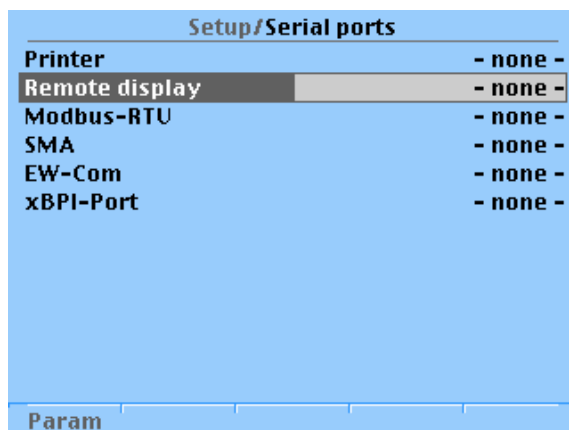

1. Select [Remote display] and confirm.
 - ▷ A selection window opens.
2. Select the desired interface and confirm.
 - ▷ The selected interface is displayed.

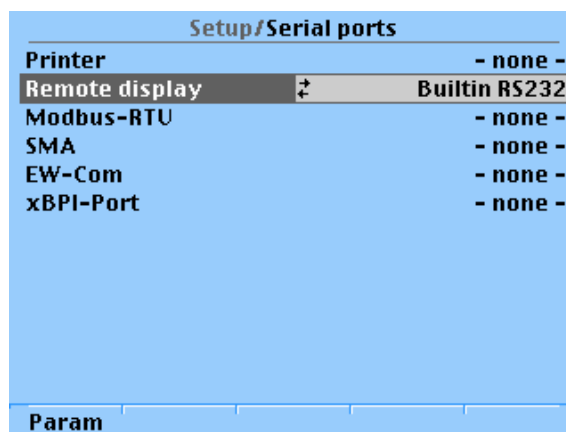

3. Press the [Param] softkey to set the parameters.
 - ▷ The following window opens:

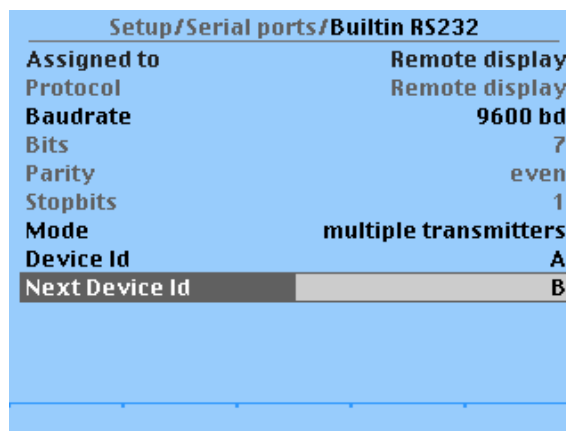

4. Select [Baudrate] and confirm.
 - ▷ A selection window opens.
5. Select the desired transmission speed and confirm.

6. Select [Mode] and confirm.
7. If several remote displays are connected, select the "multiple transmitters" mode. If only 1 instrument is connected to a remote display (normal case), [Mode] must be set to "single transmitter".
8. Enter the unique device address (in this case: A) and the address of the device that follows (in this case: B) and confirm.
9. Press **Exit** two times to exit the menu and save.

7.18.1.3 ModBus RTU protocol

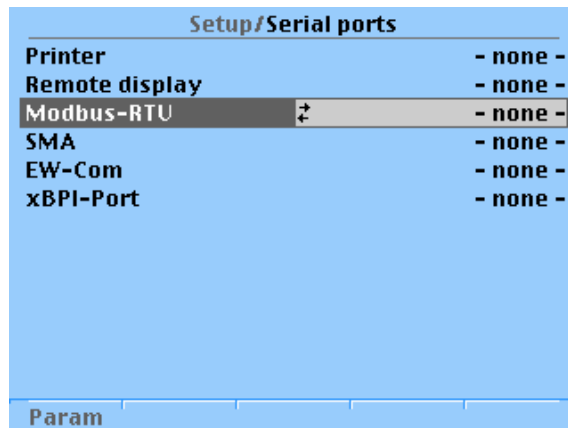

1. Select [ModBus-RTU] and confirm.
 - ▷ A selection window opens.
2. Select the desired interface and confirm.
 - ▷ The selected interface is displayed.

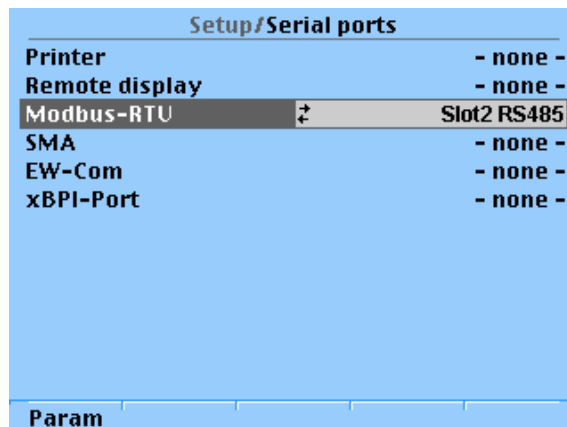

3. Press the [Param] softkey to set the parameters.

- ▷ The following window opens:

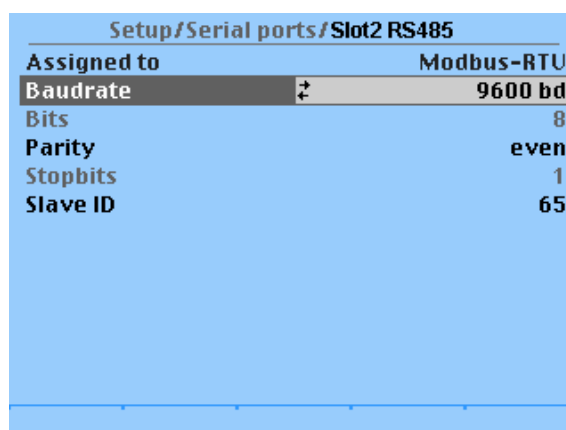

4. Select [Baudrate] and confirm.
 - ▷ A selection window opens.
5. Select the desired transmission speed and confirm.
6. Select [Parity] and confirm.
 - ▷ A selection window opens.
7. Select the desired parity and confirm.
8. Select [Slave ID] and confirm.
9. Enter and confirm the slave address (in this case: 65).
10. Press Exit 2x to exit the menu and save.

7.18.1.4 SMA protocol

Note:

The PR 5510/04 interface card must be installed in the device (see Chapter 4.7).

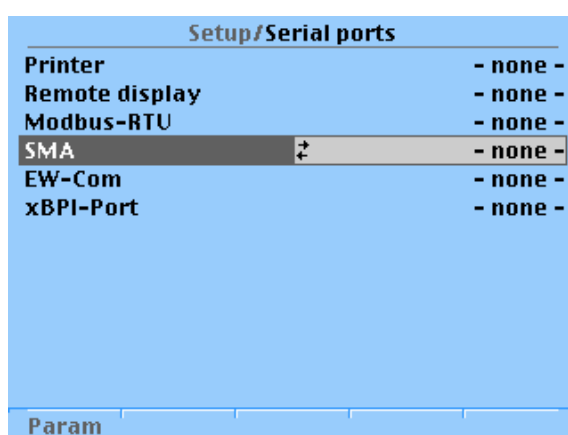

1. Select [SMA] and confirm.
 - ▷ A selection window opens.
2. Select the desired interface and confirm.

- ▷ The selected interface is displayed.

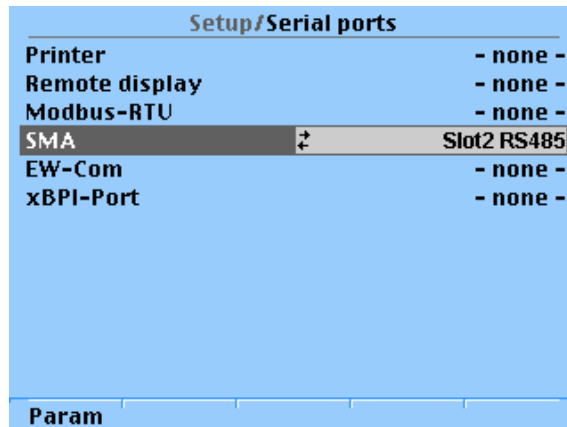

3. Press the [Param] softkey to set the parameters.

- ▷ The following window opens:

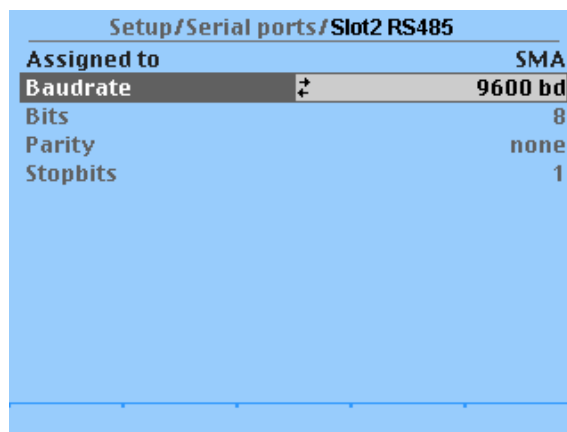

4. Select [Baudrate] and confirm.
 - ▷ A selection window opens.
5. Select the desired transmission speed and confirm.
6. Press ^{Exit} two times to exit the menu and save.

7.18.1.5 EW-Com protocol

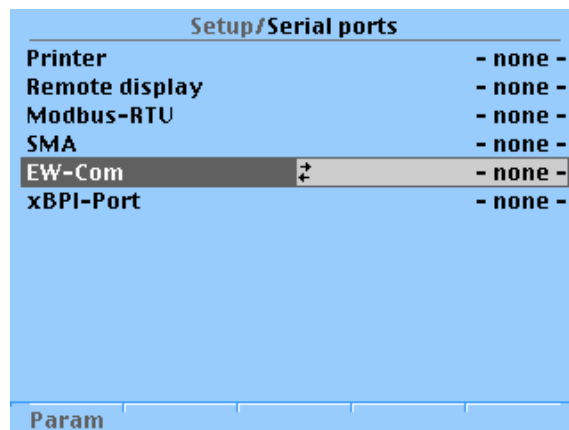

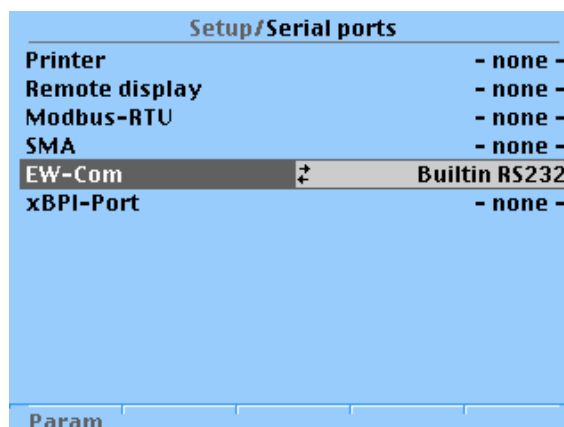

1. Select [EW-COM] and confirm.
 - ▷ A selection window opens.

2. Select the desired interface and confirm.
 - ▷ The selected interface is displayed.

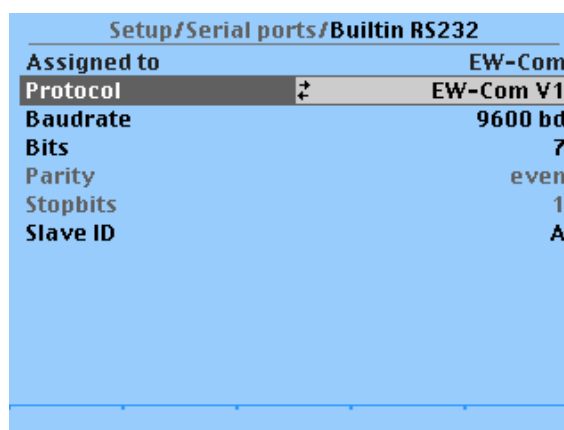

3. Press the [Param] softkey to set the parameters.
 - ▷ The following window opens:



4. Select [Protocol] and confirm.
 - ▷ A selection window opens.
 - V1 = for old communication programs
 - V2 = for formulation controller
 - V3 = for OPC
5. Confirm the desired selection.
6. Select [Baudrate] and confirm.
 - A selection window opens.
7. Select the desired transmission speed and confirm.
8. Select [Bits] and confirm.
 - A selection window opens.
9. Select the desired bit quantity and confirm.
10. Select [Slave ID] and confirm.
11. Enter the address (A–Z) and confirm.
12. Press  two times to exit the menu and save.

7.18.1.6 xBPI protocol

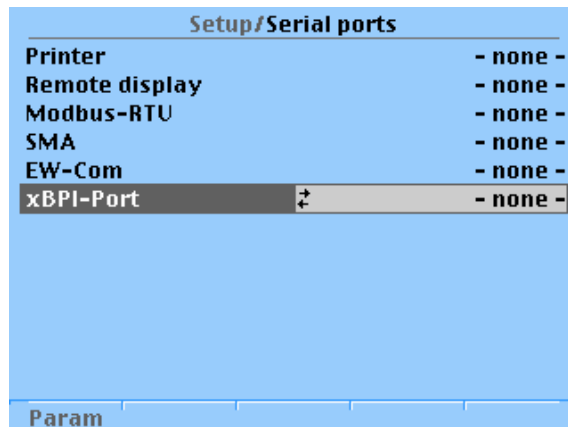

1. Select [xBPI-Port] and confirm.
 - ▷ A selection window opens.
2. Select the desired interface and confirm.
 - ▷ The selected interface is displayed.

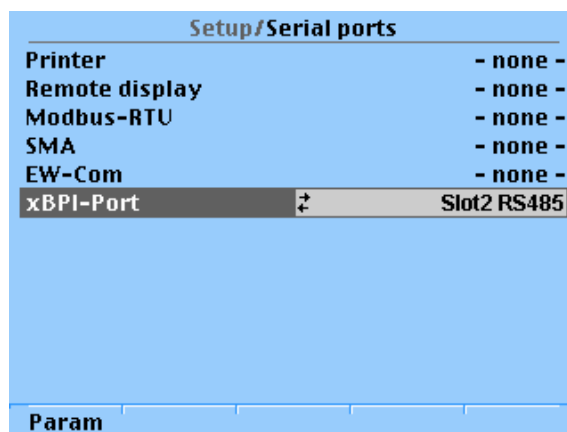

3. Press the [Param] softkey to set the parameters.
 - ▷ The following window opens:

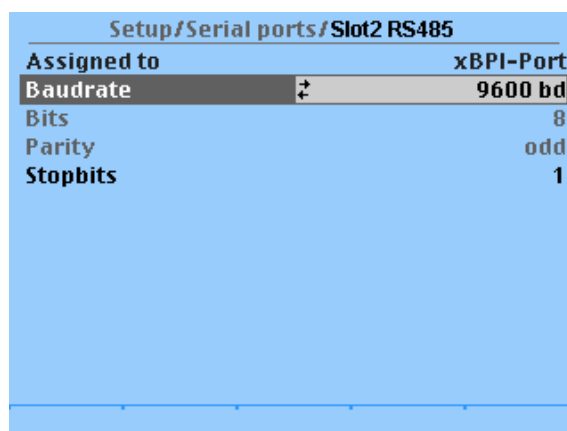

4. Select [Baudrate] and confirm.
 - ▷ A selection window opens.
5. Select the desired transmission speed and confirm.

6. Select [Stopbits] and confirm.
 - ▷ A selection window opens.
7. Select the desired stopbit and confirm.
8. Press  two times to exit the menu and save.

7.18.2 Date and time

The date and time are set under this menu item.

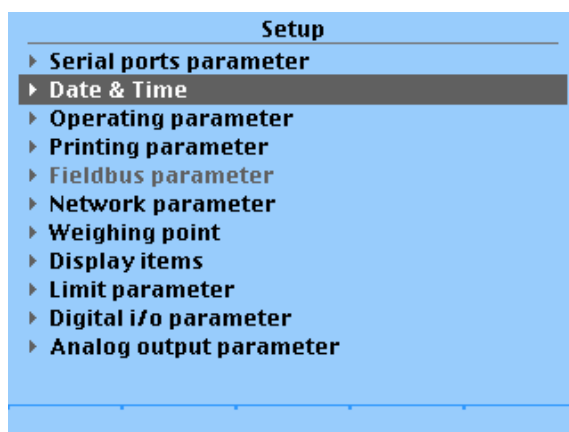

1. Select [Date & Time] and confirm.
 - ▷ The following window opens:

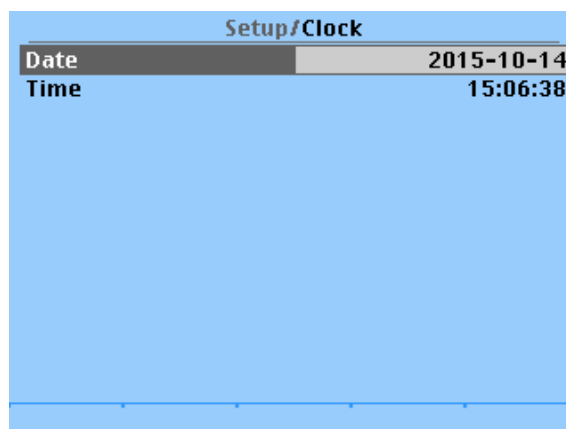

2. Select the individual digits and use the keypad to overwrite them and confirm.

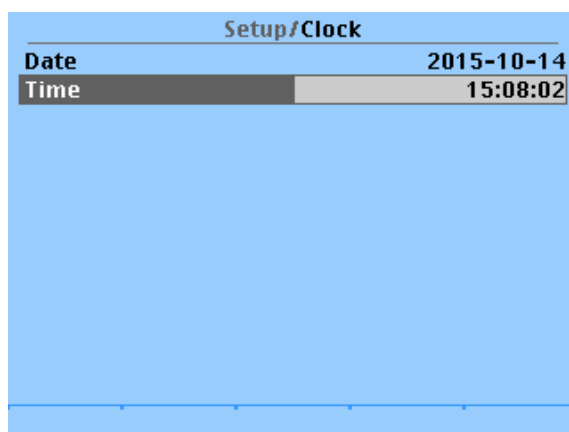

3. Select the individual digits and use the keypad to overwrite them and confirm.
4. Press  to exit the menu and save.

7.18.3 Operating parameters

The operating parameters are set under this menu item.

Open the menu via -[Operating parameter].

Setup/Operating parameter	
Application	Standard
Address	A
PIN	0
Use alibi memory	Net
Sequence number	1
Set Tare Key	tare & reset tare
SetZeroKey	only when not tared
N-B-T-Key	enabled
PrintKey	enabled
TestKey	enabled

[Application]

Application selection: Standard, EasyFill

[Address]

Enter device address, e.g. for printout.

Input: A...Z

[PIN]

The access code can be used to protect the system setup from unauthorized operation.

Input: number with up to 6 digits

As long as you are in this menu, the value can be overwritten as required.

If the [PIN] is set to "0", no access code prompt is displayed.

Note:

SUPER PIN

If the PIN-Code is lost, the setup can be unlocked with Super-PIN "212223."

[Use alibi memory]

Using the alibi memory

The weight values stored in the alibi memory are defined here:

none (do not store any data records); Gross; Net; Gross,Net,Tare; Gross,Net; Gross,Tare

[Sequence number]

The sequence number (counter for print jobs) is incremented automatically (max. 999999999) and can be set to a start value here as appropriate.

The sequence number can also be shown on the printout (selectable).

Note:

This menu item is only available if under -[Operating parameter]- [Application] "Standard" has been selected.

[SetTareKey]

Selection: disabled, tare & reset tare, tare & tare again

The tare function (operation via VNC/Internet Browser) can be toggled:

- [tare & reset tare] means that the device will be tared if it has not been tared previously and the tare will be reset if the device has already been tared.
- [tare & tare again] means that each time a tare command is given, the instant value in the tare memory is applied and the net display switches to 0.

The tare key has no function when set to [disabled].

[SetZeroKey]

Selection: disabled, only when not tared, reset tare on zeroset



The function of the zero-setting key (operation via VNC/Internet Browser) can be restricted with [only when not tared] to the gross mode or automatically toggle with [reset tare on zeroset] to the gross mode.

If the zero-setting key with these settings has no effect, the configured zero-setting range (around the zero-point set with the dead load) is already utilized due to a previous zero-setting operation and/or automatic zero setting.

The setting to zero is deactivated by [disabled].

[N-B-T-Key], [PrintKey], [TestKey]

The following front-panel keys can be disabled by selecting "disabled":

- 
- 
- 

Selecting [enabled] allows operation of these keys again.

Response on the device display If disabled keys are pressed, **LoCKEd** appears on the display.

Press  to return to the Setup menu.

The following prompt window appears if parameters were changed.

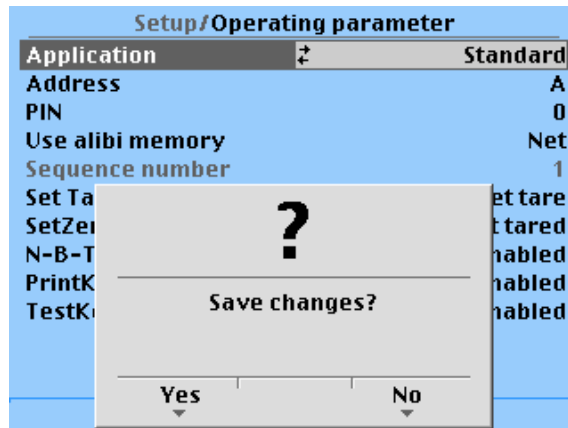

Save the data with [Yes].

Press [No] to exit the menu without changing data.

7.18.4 Print parameters

Note:

This menu item is only available if under -[Operating parameter]- [Application] "Standard" has been selected.

The print parameters are set under this menu item.

Open the menu via -[Printing parameter].

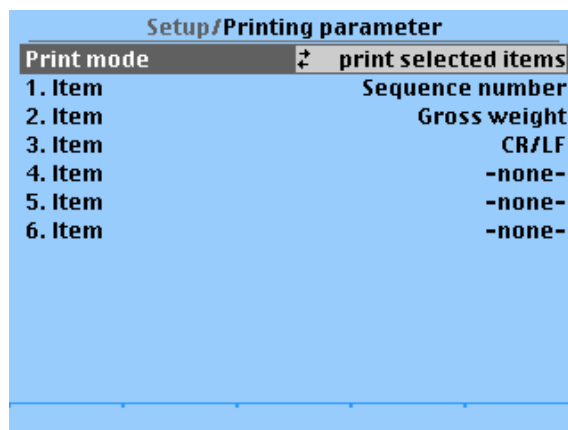

[Print mode]

Printing mode

Selection: <Print selected items>, via Nice Lable [configure printout with Nice Label Express (NLE)].

[1. ... 6. Item]

Print layout for line 1...6

Selection: -none- (no printout; selected if fewer than 6 elements will be printed), Gross weight, Net weight, Tare weight, Date & Time (printed in format DD.MM.YYYY HH:MM:SS), Sequence number (counter for individual print orders, max. 6 digits, #000001 comes after #999999), CR/LF (carriage return and line feed), Device address, displayed weight, Formfeed

Note:

If [OIML], [NTEP], or [NSC] has been selected, printing is done only if the stability criteria is fulfilled.

The weight is shown in "<>".

For [NTEP] or [NSC] the gross weight is indicated with G (otherwise B).

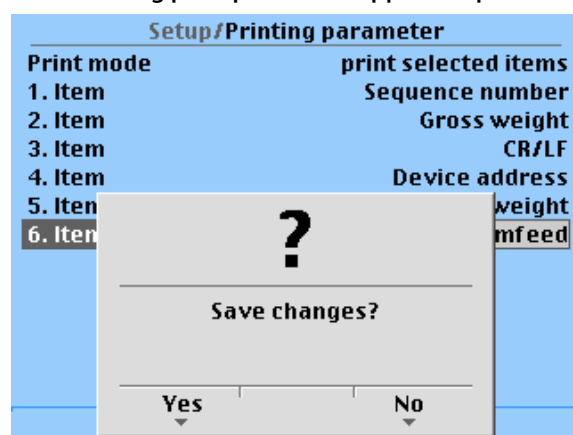

Press  to return to the Setup menu.

The following prompt window appears if parameters were changed.



Save the data with [Yes].

Press [No] to exit the menu without changing data.

If a printer has been connected and set up (see Chapter 7.18.1.1), the configuration printout can be triggered via the  and  keys (clicked one after the other).

7.18.5 Fieldbus parameters

The fieldbus parameters are set under this menu item.

Open the menu via -[Fieldbus parameter].

This menu item can only be selected if a fieldbus card is installed.

The protocol displayed automatically depends on of the installed fieldbus card:

- [ProfiBus-DP] for PR 1721/31
- [InterBus-S] for PR 1721/32
- [DeviceNet] for PR 1721/34
- [CC-Link] for PR 1721/35

Note:

This fieldbus card does **not** support the "EasyFill" application.

- [ProfiNet I/O] for PR 1721/36
- [EtherNet-IP] for PR 1721/37

Example:

PR 1721/36 ProfiNet I/O

Setup/Fieldbus parameter	
Fieldbus protocol	Profinet
IP address	172.24.22.125
Subnet mask	255.255.240.0

Note:

The individual parameters depend on the fieldbus type.

Press  to return to the Setup menu.

The following prompt window appears:

Setup/Fieldbus parameter	
Fieldbus protocol	Profinet
IP address	172.24.22.125
Subnet mask	255.255.240.0

?
Save changes?
<input type="button" value="Yes"/> <input type="button" value="No"/>

Save the data with [Yes].

Press [No] to exit the menu without changing data.

7.18.5.1 ProfiBus-DP settings for S7**Requirements:**

- PR 1721/31 ProfiBus-DP is installed.
- The parameters are selected and saved.

Procedure:

1. Establish communication with the PLC (here: SIEMENS S7-300/400 or S7-1500).
2. Create/open a project in the "SIMATIC MANAGER."
3. Load the file "sart5410.gsd" from CD and install it in the development environment.
4. Add the PR 5410 device to the project and assign the I/O ranges.

Note:

See Chapter [12.2](#)

Example:

The gross weight should be read.

I/O size = 8 bytes, counted from byte 0–7

7.18.5.2 DeviceNet settings for Rockwell workstation

Requirements:

- PR 1721/34 DeviceNet is installed.
- The parameters are selected and saved.

Procedure:

1. Register the file "sag_5410.eds" using the "Hardware Installation Tool".
2. Select and insert the instrument from the catalog into the I/O configuration.

Note:

See Chapter [12.2](#)

Example:

The gross weight should be read.

I/O size = 8 bytes, counted from byte 0–7

7.18.5.3 ProfiNet I/O settings for S7

Requirements:

- PR 1721/36 ProfiNet I/O is installed.

Procedure:

1. Establish communication with the PLC (here: SIEMENS S7-300/400 or S7-1500).

NOTICE**Potential network problems**

- ▶ A unique device name must be assigned for the hardware configuration and assignment/download.

-
2. Enter the IP address and network mask under  - [Fieldbus parameter] and confirm.
 3. Add the PR 5410 device to the project and assign the I/O ranges.

Note:

See Chapter [12.2](#)

Example:

The gross weight should be read.

I/O size = 8 bytes, counted from byte 0–7

4. Assign the instrument name to the PR 5410.

7.18.5.4 EtherNet-IP settings for Rockwell workstation**Requirements:**

- PR 1721/37 DeviceNet EtherNet-IP is installed.

Procedure:

1. Enter the IP address and network mask under  - [Fieldbus parameter] and confirm.
2. Register the file "sag_5410_Ethernetip.eds" using the "Hardware Installation Tool".
3. Select and insert the instrument from the catalog into the I/O configuration.

Note:

See Chapter [12.2](#)

Example:

The gross weight should be read.

I/O size = 8 bytes, counted from byte 0–7

7.18.6 Network parameters

Under this menu item, you can define the network parameters for the network connections (built-in LAN adapter).

Open the menu via  - [Network parameter].

Setup/Network parameter	
HW address	00:90:6C:6A:6B:5E
Hostname	PR5410-6A6B5E
Use DHCP	<input checked="" type="checkbox"/>
IP address	172.24.20.93
Subnet mask	255.255.240.0
Default gateway	172.24.16.1
Remote access	
VNC-Client	255.255.255.255

[HW address]

This parameter cannot be changed because the fixed address is specified by the instrument.

[Hostname]**NOTICE****Potential network problems**

- ▶ The host name must be unique in the network!

The user-defined device name is subject to the following restrictions:

- Minimum number of characters: 2, maximum number of characters: 24.
- The first character must be a letter. Spaces are not permitted.
- 0–9, A-Z (not case-sensitive) are permitted.
- - or . may be included, but neither at the end nor in succession.

Input: via keypad

[DHCP]

If is checked (presettings: DHCP selected), the server automatically allocates the IP address, subnet mask, and default gateway.

If is not checked, the settings [IP address], [Subnetmask] and [Default gateway] must be defined in consultation with the responsible system administrator.

[VNC client]

This address can be used to allow access to the interface for remote access, see following table.

User	address	Description
VNC client	0.0.0.0.	Access via VNC not permitted.
VNC client	172.24.21.101	Access only from client machine with this address.
VNC client	172.24.21.255	Access from any client with address within range 172.24.21.1 - ..254.
VNC client	255.255.255.255	Access from client with any address.

Note:

When setting [IP Address], [Subnetmask], and [Default gateway], please consult with your system administrator.

Press  to return to the Setup menu and to save the changes.

7.18.7 Configuring limit values**Note:**

This menu item is only available if under -[Operating parameter]- [Application] "Standard" has been selected.

The parameters for limits are set under this menu item.

Each limit consists of a switch-on and a switch-off point for definition of a hysteresis. The 3 pairs of values must be entered according to the same principle. The limit values always refer to the gross weight. For the SPM addresses for the limits, see Chapter [13.4](#).

NOTICE

The limit values of an xBPI weighing point are scale-specific.

The scale must be active when entering the limit values.

- ▶ The scale and the unit must not be changed after configuration.
- ▶ The following settings are required: [Weighingpoint/xBPI-Scale] - [Setup] - [Configuration] - [Application settings] - [Number of units] "1 Weight"

Define the parameters for limits under -[Limit parameter].

Setup/Limit parameter			
Limit 1 on			0 kg
	Action	-no action-	
Limit 1 off			0 kg
	Action	-no action-	
Limit 2 on			0 kg
	Action	-no action-	
Limit 2 off			0 kg
	Action	-no action-	
Limit 3 on			0 kg
	Action	-no action-	
Limit 3 off			0 kg
	Action	-no action-	

For the configuration the following order must be followed:

1. Define limits.
2. Define an action.
3. Determine a condition.
4. Save parameters.

7.18.7.1 Defining limits

Example 1:

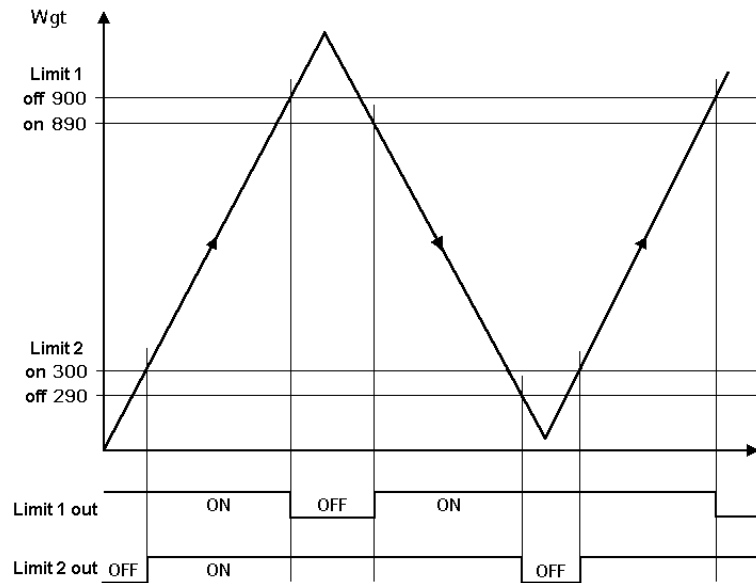

The output signal (Limit 1 out) of limit 1 switches OFF above a weight (Wgt) of 900 kg.

The output signal (Limit 2 out) of Limit 2 switches OFF below 290 kg.

The two limit values have a hysteresis of 10 kg.

In the event of a power failure both outputs turn to "off" ("OFF"), thus indicating underfill and overfill simultaneously.

Example 2:

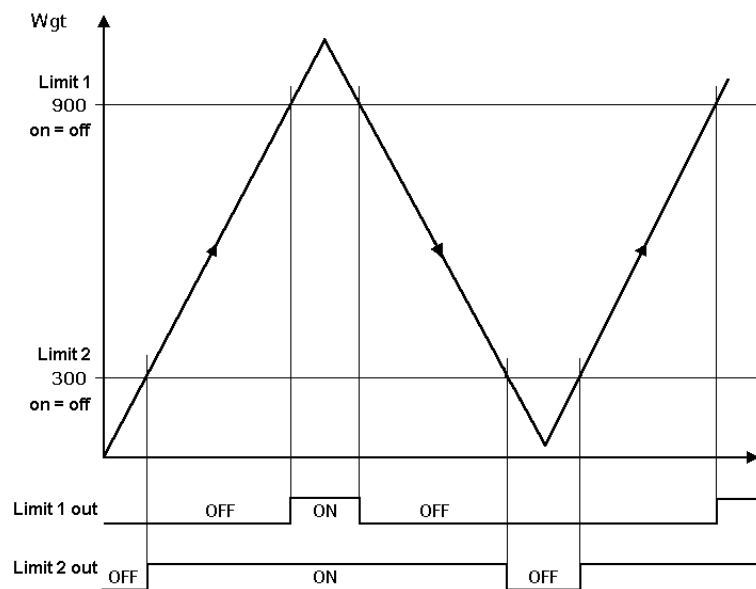

If the Limits 1 and 2 are the same for "On" and "Off" (on = off),

- switches output 1 (Limit 1 out) ON if the weight (Wgt) exceeds the value.
- switches output 2 (Limit 2 out) OFF if the weight falls below the value.

Setup/Limit parameter		
Limit 1 on		900 kg
	Action	-no action-
Limit 1 off		900 kg
	Action	-no action-
Limit 2 on		300 kg
	Action	-no action-
Limit 2 off		300 kg
	Action	-no action-
Limit 3 on		0 kg
	Action	-no action-
Limit 3 off		0 kg
	Action	-no action-

1. Select the appropriate lines.
2. Use the keypad to enter and confirm the desired values (in this case: see Example 2).

7.18.7.2 Defining an action

The possible actions are listed in the following table.

Selection list for the actions [Action]

Function	SPM Bit	Description
-no action-	---	no function
set marker 1	X64 = 1	Set marker 1
set marker 2	X65 = 1	Set marker 2
set marker 3	X66 = 1	Set marker 3
clr marker 1	X64 = 0	Clear marker 1
clr marker 2	X65 = 0	Clear marker 2
clr marker 3	X66 = 0	Clear marker 3

Note:

The limit values can be assigned to the outputs directly in the I/O parameters.

Markers can be set for all limits (in this case, see Example 2):

Setup/Limit parameter		
Limit 1 on		900 kg
	Action ↕	-no action-
Limit 1 off		900 kg
	Action	-no action-
Limit 2 on		300 kg
	Action	-no action-
Limit 2 off		300 kg
	Action	-no action-
Limit 3 on		0 kg
	Action	-no action-
Limit 3 off		0 kg
	Action	-no action-

1. Highlight and confirm the action line of the appropriate limit using the cursor.

- ▷ A selection window opens.

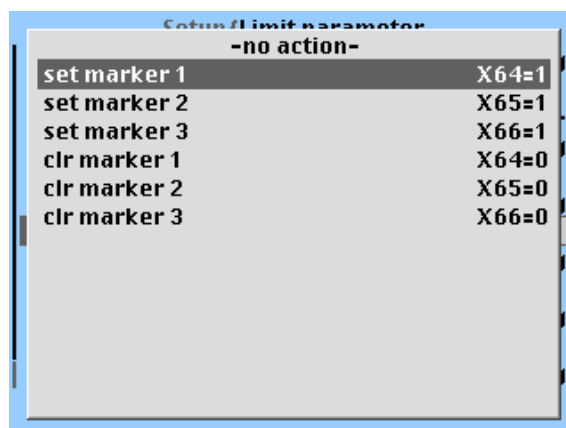

2. Select and confirm the appropriate line to set the marker for the corresponding limit (in this case, Marker 1 is set when 900 g is exceeded).
3. If applicable, set additional markers and confirm.

7.18.7.3 Determining a condition

Additionally, a [Condition] can be assigned to the marker.

The possible conditions are listed in the following table.

Selection list for [conditions]

Function	SPM Bit	Description
no condition	---	No condition
actual diginp1	X00 = 0	digital input 1: not active
actual diginp2	X01 = 0	digital input 2: not active
actual diginp3	X02 = 0	digital input 3: not active
actual limit 1	X16 = 0	Limiting signal 1: not active
actual limit 2	X17 = 0	Limiting signal 2: not active
actual limit 3	X18 = 0	Limiting signal 3: not active
ADC error	X32 = 0	General error in weighing point: not active (no error)
above Max	X33 = 0	Weight above Max: not active
overload	X34 = 0	Weight above Max plus the 'overload' value: not active
below zero	X35 = 0	Weight not below zero
center zero	X36 = 0	Weight not within ¼ d of zero
inside ZSR	X37 = 0	Weight not within zero-setting range
standstill	X38 = 0	Standstill not active
out	X39 = 0	Weight not below zero or above Max
command error	X48 = 0	For internal use only.
command busy	X49 = 0	For internal use only.

Function	SPM Bit	Description
power fail	X50 = 0	Set after power-on (=power failure): not active
test active	X56 = 0	Analog test was not started.
cal active	X57 = 0	For internal use only.
tare active	X58 = 0	Instrument is not tared.
marker bit 1	X64 = 0	Marker bit 1 not set, after power-on the markers are set to "0".
marker bit 2	X65 = 0	Marker bit 2 not set, after power-on the markers are set to "0".
marker bit 3	X66 = 0	Marker bit 3 not set, after power-on the markers are set to "0".
actual diginp1	X00 = 1	digital input 1: active
actual diginp2	X01 = 1	digital input 2: active
actual diginp3	X02 = 1	digital input 3: active
actual limit 1	X16 = 1	Limiting signal 1: active
actual limit 2	X17 = 1	Limiting signal 2: active
actual limit 3	X18 = 1	Limiting signal 3: active
ADC error	X32 = 1	General error in the weighing point
above Max	X33 = 1	Weight above Max
overload	X34 = 1	Weight above Max plus the 'overload' value
below zero	X35 = 1	Weight below zero
center zero	X36 = 1	Weight within ¼ d of zero
inside ZSR	X37 = 1	Weight within zero-setting range
standstill	X38 = 1	Standstill is active
out	X39 = 1	Weight below zero or above Max
command error	X48 = 1	For internal use only.
command busy	X49 = 1	For internal use only.
power fail	X50 = 1	Set after power-on (=power failure)
test active	X56 = 1	Analog test was started.
cal active	X57 = 1	For internal use only.
tare active	X58 = 1	Instrument is tared.
marker bit 1	X64 = 1	Marker bit 1 set, after power-on the markers are set to "0".
marker bit 2	X65 = 1	Marker bit 2 set, after power-on the markers are set to "0".

Function	SPM Bit	Description
marker bit 3	X66 = 1	Marker bit 3 set, after power-on the markers are set to "0".

Setup/Limit parameter		
Limit 1 on	900 kg	
Action	set marker 1	X64=1
Condition	no condition	-----
Limit 1 off	900 kg	
Action	-no action-	
Limit 2 on	300 kg	
Action	-no action-	
Limit 2 off	300 kg	
Action	-no action-	
Limit 3 on	0 kg	
Action	-no action-	
Limit 3 off	0 kg	

1. Highlight and confirm the condition line of the appropriate limit using the cursor.
 - ▷ A selection window opens.

Setup/Limit parameter	
act. diginp 1	X00=1
act. diginp 2	X01=1
act. diginp 3	X02=1
limit 1 out	X16=1
limit 2 out	X17=1
limit 3 out	X18=1
ADU error	X32=1
above MAX	X33=1
overload	X34=1
below zero	X35=1
center zero	X36=1
inside ZSR	X37=1
standstill	X38=1

2. Select and confirm the appropriate line (here: Standstill is active).
3. If applicable, select additional conditions for the other limits and confirm.

7.18.7.4 Saving parameters

- ▶ Press the  softkey to exit the menu.

7.18.8 Configuring digital inputs

An action both for signal change from 0 to 1 (on) and from 1 to 0 (off) can be determined for each of the three inputs.

Digital inputs can be linked with conditions that must be met before an action can be started.

The parameters for the digital inputs are defined under -[Digital i/o parameter].

Note:

This menu item is only available if under -[Operating parameter]- [Application] "Standard" has been selected.

Setup/Digital i/o parameter		
Output 1	↕marker bit 1	X64=1
Output 2	marker bit 2	X65=1
Output 3	marker bit 3	X66=1
Input 1 on	-no action-	
Input 1 off	-no action-	
Input 2 on	-no action-	
Input 2 off	-no action-	
Input 3 on	-no action-	
Input 3 off	-no action-	

For the configuration the following order must be followed:

1. Defining an action
2. Determining a condition
3. Saving parameters

7.18.8.1 Defining an action

The possible actions are listed in the following table.

Selection list for actions of the inputs [Input 1/2/3 on/off]

Function	SPM Bit	Description
-no action-	---	no function
set marker 1	X64 = 1	Set marker 1
set marker 2	X65 = 1	Set marker 2
set marker 3	X66 = 1	Set marker 3
select net	X72 = 1	Select net
set zero	X112 = 1	Set zero
set tare	X113 = 1	Set tare
reset tare	X114 = 1	Reset tare
set test	X115 = 1	Activate the analog test
reset test	X116 = 1	Finish the analog test
reset PWF	X117 = 1	Reset power fail
set fixtare	X118 = 1	Set fixtare (use the value in address D31 as a tare value)
get fixtare	X119 = 1	Save gross value as fixtare in address D31
clr marker 1	X64 = 0	Clear marker 1

Function	SPM Bit	Description
clr marker 2	X65 = 0	Clear marker 2
clr marker 3	X66 = 0	Clear marker 3
select gross	X72 = 0	Save the gross weight in address D11

Actions can be selected (bits set) for all digital inputs (see table).

Setup/Digital i/o parameter		
Output 1	marker bit 1	X64=1
Output 2	marker bit 2	X65=1
Output 3	marker bit 3	X66=1
Input 1 on	↕	-no action-
Input 1 off		-no action-
Input 2 on		-no action-
Input 2 off		-no action-
Input 3 on		-no action-
Input 3 off		-no action-

1. Select the appropriate line using the cursor (here: Input 1 on) and confirm.

Define the action for the rising edge of Input 1 (in this case: When the input signal changes from 0 to 1, a tare command is generated).

Accordingly, an action for the falling edge can be determined.

- ▷ A selection window opens.

Setup/Digital i/o parameter		
		-no action-
set marker 1		X64=1
set marker 2		X65=1
set marker 3		X66=1
select net		X72=1
set zero		X112=1
set tare		X113=1
reset tare		X114=1
set test		X115=1
reset test		X116=1
reset PWF		X117=1
set fixtare		X118=1
get fixtare		X119=1

2. Select and confirm the appropriate line.
3. If applicable, select additional actions (setting bits) and confirm.

7.18.8.2 Determining a condition

The selected action of each digital input can be combined with a condition that must be met for signal change from 0 to 1 (on) or for signal change from 1 to 0 (off). The condition is selected from the list in Chapter [7.18.7.3](#).

No condition is defined when selecting [no condition]. The action is executed directly.

Setup/Digital i/o parameter		
Output 1	marker bit 1	X64=1
Output 2	marker bit 2	X65=1
Output 3	marker bit 3	X66=1
Input 1 on	set tare	X113=1
	Condition	↕no condition -----
Input 1 off		-no action-
Input 2 on		-no action-
Input 2 off		-no action-
Input 3 on		-no action-
Input 3 off		-no action-

1. Select and confirm the condition line of the appropriate parameter.
 - ▷ A selection window opens.

Setup/Digital i/o parameter	
act. diginp 1	X00=1
act. diginp 2	X01=1
act. diginp 3	X02=1
limit 1 out	X16=1
limit 2 out	X17=1
limit 3 out	X18=1
ADU error	X32=1
above MAX	X33=1
overload	X34=1
below zero	X35=1
center zero	X36=1
inside ZSR	X37=1
standstill	X38=1

2. Select and confirm the appropriate line (here: If input 1 changes from 0 to 1 [Input 1 on], a taring signal is triggered only, if the condition under [Condition] is met (limit 1 out = active)).
3. If applicable, select additional conditions for the other parameter and confirm.

7.18.8.3 Saving parameters

- ▶ Press the  softkey to exit the menu.

7.18.9 Configuring digital outputs

Configure the required function for [Output 1] to [Output 3] by selecting a signal from the list.

The output is set to the corresponding state.

Selection list for output functions

Function	SPM Bit	Description
no condition	---	No condition
actual diginp1	X00 = 0	digital input 1: not active
actual diginp2	X01 = 0	digital input 2: not active
actual diginp3	X02 = 0	digital input 3: not active

Function	SPM Bit	Description
limit 1 out	X16 = 0	Limiting signal 1: not active
limit 2 out	X17 = 0	Limiting signal 2: not active
limit 3 out	X18 = 0	Limiting signal 3: not active
ADC error	X32 = 0	General error in weighing point: not active (no error)
above Max	X33 = 0	Weight above Max: not active
overload	X34 = 0	Weight above Max plus the 'overload' value: not active
below zero	X35 = 0	Weight not below zero
center zero	X36 = 0	Weight not within $\frac{1}{4}$ d of zero
inside ZSR	X37 = 0	Weight not within zero-setting range
standstill	X38 = 0	Standstill not active
out (of range)	X39 = 0	Weight not below zero or above Max
command error	X48 = 0	For internal use only.
command busy	X49 = 0	For internal use only.
power fail	X50 = 0	Set after power-on (=power failure): not active
test active	X56 = 0	Analog test was not started.
cal active	X57 = 0	For internal use only.
tare active	X58 = 0	Instrument is not tared.
marker bit 1	X64 = 0	Marker bit 1 not set, after power-on the markers are set to "0".
marker bit 2	X65 = 0	Marker bit 2 not set, after power-on the markers are set to "0".
marker bit 3	X66 = 0	Marker bit 3 not set, after power-on the markers are set to "0".
actual diginp1	X00 = 1	digital input 1: active
actual diginp2	X01 = 1	digital input 2: active
actual diginp3	X02 = 1	digital input 3: active
limit 1 out	X16 = 1	Limiting signal 1: active
limit 2 out	X17 = 1	Limiting signal 2: active
limit 3 out	X18 = 1	Limiting signal 3: active
ADC error	X32 = 1	General error in the weighing point
above Max	X33 = 1	Weight above Max
overload	X34 = 1	Weight above Max plus the 'overload' value
below zero	X35 = 1	Weight below zero

Function	SPM Bit	Description
center zero	X36 = 1	Weight within ¼ d of zero
inside ZSR	X37 = 1	Weight within zero-setting range
standstill	X38 = 1	Standstill is active
out (of range)	X39 = 1	Weight below zero or above Max
command error	X48 = 1	For internal use only.
command busy	X49 = 1	For internal use only.
power fail	X50 = 1	Set after power-on (=power failure)
test active	X56 = 1	Analog test was started.
cal active	X57 = 1	For internal use only.
tare active	X58 = 1	Instrument is tared.
marker bit 1	X64 = 1	Marker bit 1 set, after power-on the markers are set to "0".
marker bit 2	X65 = 1	Marker bit 2 set, after power-on the markers are set to "0".
marker bit 3	X66 = 1	Marker bit 3 set, after power-on the markers are set to "0".

Example: [overload] function

SPM Bit [X34 = 1]

Function and output are active (e.g.: if 'overload' is reached, a lamp is lit).

SPM Bit [X34 = 0]

Function is active and output is not active (e.g.: if "overload" is reached, a lamp goes out).

The parameters for the digital outputs are defined under -[Digital i/o parameter].

Note:

This menu item is only available if under -[Operating parameter]- [Application] "Standard" has been selected.

Example:

Setup/Digital i/o parameter		
Output 1	↕marker bit 1	X64=1
Output 2	marker bit 2	X65=1
Output 3	marker bit 3	X66=1
Input 1 on		-no action-
Input 1 off		-no action-
Input 2 on		-no action-
Input 2 off		-no action-
Input 3 on		-no action-
Input 3 off		-no action-

1. Select [Output 1] and confirm.
 - ▷ A selection window opens.

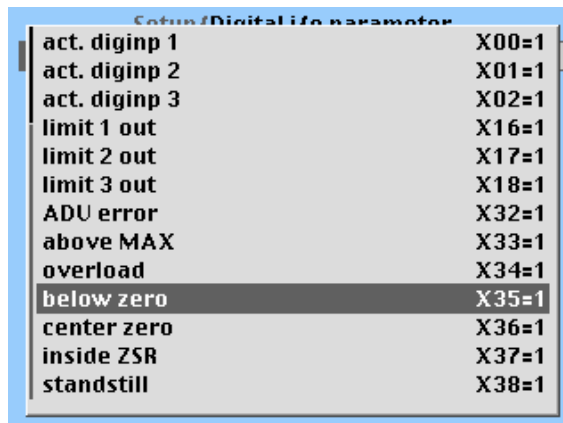

Setup Digital life parameter	
act. diginp 1	X00=1
act. diginp 2	X01=1
act. diginp 3	X02=1
limit 1 out	X16=1
limit 2 out	X17=1
limit 3 out	X18=1
ADU error	X32=1
above MAX	X33=1
overload	X34=1
below zero	X35=1
center zero	X36=1
inside ZSR	X37=1
standstill	X38=1

The output 1 [Output 1] is true (active), when the weight value drops below zero (X35=1).

2. Select [below zero] and confirm.
3. Select [Output 2] and confirm.
 - ▷ A selection window opens.



Setup Digital life parameter	
act. diginp 2	X01=0
act. diginp 3	X02=0
limit 1 out	X16=0
limit 2 out	X17=0
limit 3 out	X18=0
ADU error	X32=0
above MAX	X33=0
overload	X34=0
below zero	X35=0
center zero	X36=0
inside ZSR	X37=0
standstill	X38=0
dimmed	X39=0

Output 2 [Output 2] remains (active), as long as the weight is not above Max (X33=0).

4. Select [above MAX] and confirm.
5. Select [Output 3] and confirm.

- ▷ A selection window opens.

Setup/Digital i/o parameter		
act. diginp 1		X00=1
act. diginp 2		X01=1
act. diginp 3		X02=1
limit 1 out		X16=1
limit 2 out		X17=1
limit 3 out		X18=1
ADU error		X32=1
above MAX		X33=1
overload		X34=1
below zero		X35=1
center zero		X36=1
inside ZSR		X37=1
standstill		X38=1

Output 3 [Output 3] is true (active), when the weight is zero $\pm 1/4$ d (X36=1).

6. Select [center zero] and confirm.

- ▷ The menu opens.

Setup/Digital i/o parameter		
Output 1	below zero	X35=1
Output 2	above MAX	X33=1
Output 3	center zero	X36=1
Input 1 on	-no action-	
Input 1 off	-no action-	
Input 2 on	-no action-	
Input 2 off	-no action-	
Input 3 on	-no action-	
Input 3 off	-no action-	

7. Press  to exit the menu and save.

7.18.9.1 Configuring the BCD output

Requirements:

A BCD card is installed.

The parameters for the BCD output are defined under -[Digital i/o parameter].

Note:

This menu item is only available if under -[Operating parameter]- [Application] "Standard" has been selected.

Setup/Digital i/o parameter		
Output 1	marker bit 1	X64=1
Output 2	marker bit 2	X65=1
Output 3	marker bit 3	X66=1
Input 1 on	-no action-	
Input 1 off	-no action-	
Input 2 on	-no action-	
Input 2 off	-no action-	
Input 3 on	-no action-	
Input 3 off	-no action-	
BCD out	↔	Gross

[BCD out]

Output as BCD with max. 5 decades plus preceding sign and state

Selection: Gross, Net if tared (net weight if tared, otherwise gross weight), Selected (gross or net weight depending on SPM bit X72), Transparent (value in D20 is output as BCD)

7.18.10 Configuring analog output

The weight value of the weighing point is transmitted to the output.

Define the parameters for the analog output under -[Analog output parameter].

Setup/Analog output parameter		
Analog mode	↔	no output
Analog range		0..20mA
Output on error		0mA
Output if < 0		0mA
Output if > Max		0mA
Weight at 0/4mA		0 kg
Weight at 20mA		3000 kg

The analog output can be configured according to the table below.

Parameter table

Menu item	Selection	Description
[Analog mode]	[no output]	Analog output is unused.
	[Gross D08]	Output of the gross weight.
	[Net if tared D09]	Output of the net weight, if tared; otherwise gross weight
	[Selected D11]	Output of the gross/net value on the display, dependent on SPM bit X72.
	[Transparent D30]	Output of the value in D30
[Analog range]	[0...20 mA]	Output of 0...20 mA.
	[4...20 mA]	Output of 4...20 mA.

Menu item	Selection	Description
[Output on error]	[0 mA]	Set output to 0 mA.
	[4 mA]	Set output to 4 mA.
	[20 mA]	Set output to 20 mA.
	[hold]	The last output value is held.
[Output if < 0]	[0 mA]	Set output to 0 mA.
	[4 mA]	Set output to 4 mA.
	[20 mA]	Set output to 20 mA.
	[linear]	The output drops below 4 mA down to the limit (at 4...20 mA).
	[absolute]	Absolute value
[Output if > Max]	[0 mA]	Set output to 0 mA.
	[4 mA]	Set output to 4 mA.
	[20 mA]	Set output to 20 mA.
	[linear]	Output increases above 20 mA until the limit is reached.
[Weight at 0/4 mA]		Weight value for 0/4 mA output.
[Weight at 20 mA]		Weight value for 20 mA output.

Quit the menu and save parameters by pressing .

Note:

Adapting the analog output, see Chapter [9.1.4.1](#).

7.19 System information

This menu displays system information.

You can also check inputs and outputs, see Chapter [9.1.4.2](#).

► Press  to access the menu.

Note:

 also has other functions; see Chapters [7.14.2.2](#) and [7.14.10](#).

7.19.1 Displaying the version

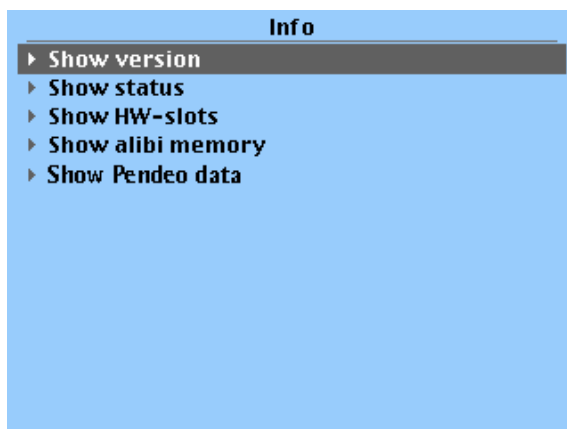

1. Confirm [Show version].

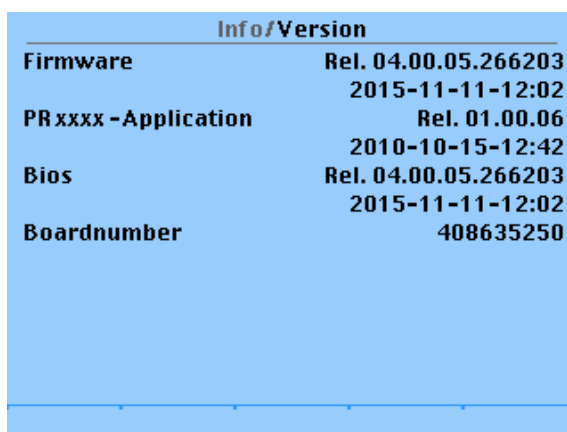

- ▷ This line shows the following information:
 - [Firmware]**
Version number and firmware creation date
 - [PRxxxx-Application]**
Version number and application creation date
 - [BIOS]**
Version number and BIOS creation date
 - [Board number]**
Nine-digit board number

2. Press  to return to the previous window.

7.19.2 Displaying the status

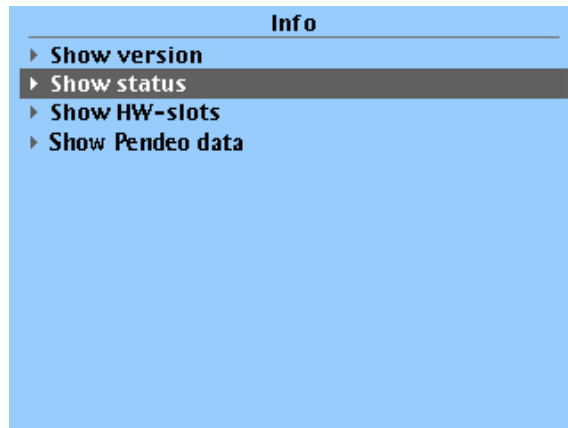

1. Select [Show status].

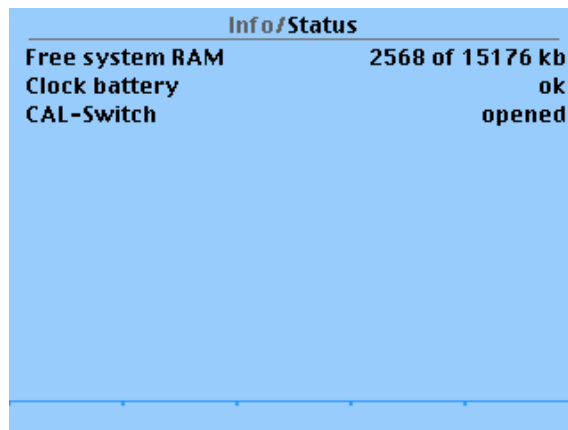

- ▷ This line shows the following device statuses:

[Free system RAM]

Free working system memory space

[Clock battery]

Status display

ok = voltage OK

low = voltage too low

[CAL switch]

Status display

[opened] = opened, no write protection.

[closed] = closed, write protection is active.

2. Press  to return to the previous window.

7.19.3 Showing hardware options

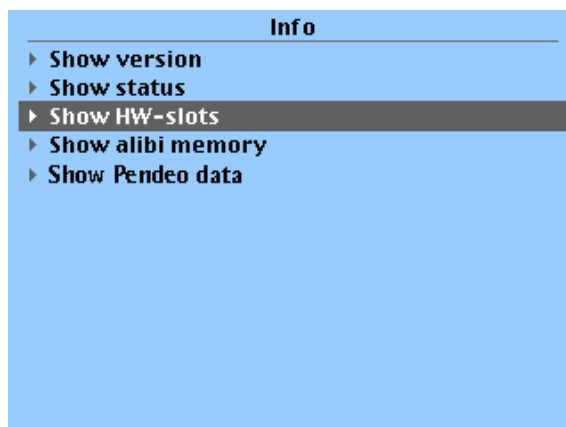

1. Select [Show HW-slots] and confirm.

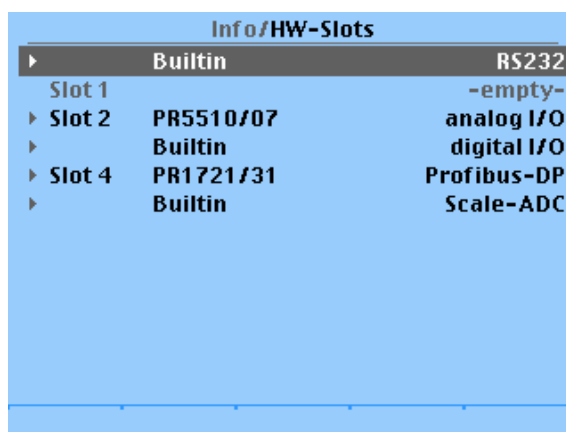

- ▷ This line shows the following device statuses:

1st line

Standard interface, serial

2nd line

In this case: Slot 1, not in use

3rd line

In this case: Slot 2, analog inputs and outputs

4th line

Standard interface, digital I/Os

5th line

In this case: Slot 4, ProfiBus-DP interface

The tool tip displays the version number.

6th line

Standard interface, weighing electronics

The tool tip displays the weighing point serial number and manufacturing date of the factory.

2. Press  to return to the previous window.

7.19.4 Displaying the alibi memory

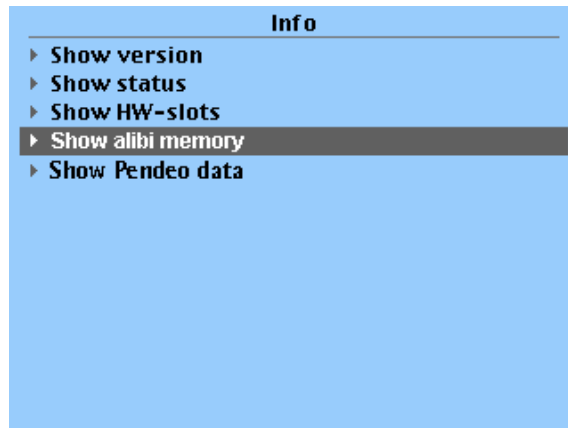

1. Select [Show alibi memory].

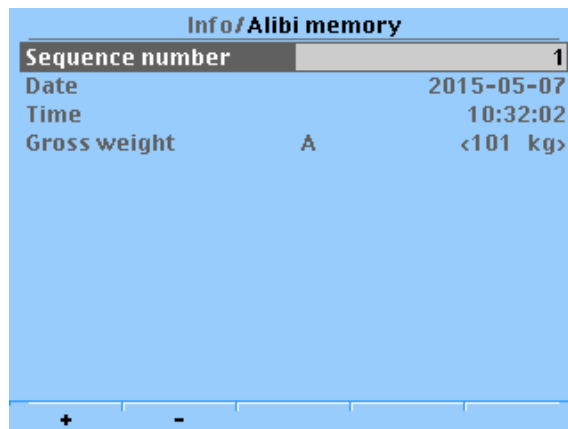

- ▷ The following saved data records are displayed:

[Sequence number]

Last entry

[Date]

Date of the last entry

[Time]

Time of the last entry

[Gross weight]

Weight type of the last entry

[+/-]

Select the next [+] or previous [-] entry.

Note:

For more information, see Chapter [9.2.7](#).

- Press  to return to the previous window.

7.19.5 Displaying Pendeo data

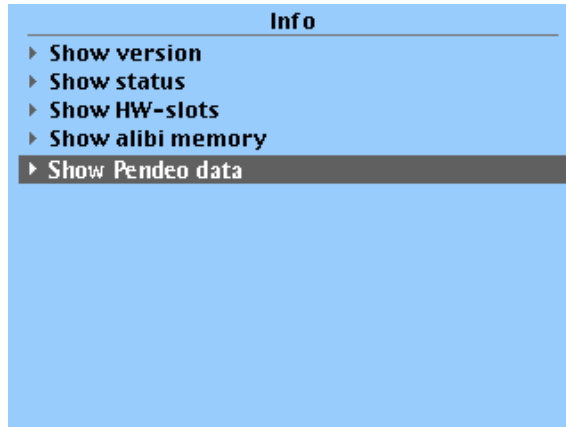

- Select [Show Pendeo data] and confirm.

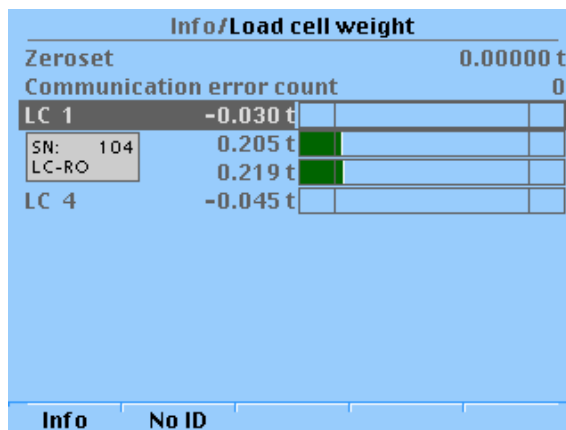

- ▷ An info window opens.

[Zero correction] (zero point correction)

The zero point correction in use is displayed.

[Communication error count] (communication error counter)

The communication errors (time frames exceeded) for the load cells are counted here in ascending order and displayed.

[LC 1...n]

Bar graph display

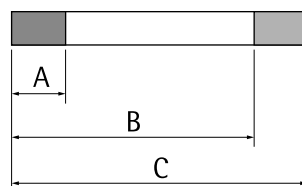

The bar graph shows three areas:

A

dead load (can be changed by calibration)

B

Maximum capacity E_{max} (max. capacity of load cell) including dead load (load cell, cannot be changed)

C

Max. load including dead load (load cell, cannot be changed)

The colors have the following meanings:

Red

Weight value is above maximum load (overload) or below $-1/4d$

Green

Weight value is within tolerances

Orange

Weight value is above maximum capacity E_{max} (max. capacity of load cell)

[No ID]

The Serial number is hidden.

[Show ID]

The Serial number is visible.

2. Select the desired load cell and press the [Info] softkey.

▷ The load cell data is displayed:

Info/Load cell weight/Load cell info	
Model name	PR6204/53tC3
Software version	01.00.04
Loadcell serial number	101
E_{max}	5.0 t
n	3000 e
Y	14000
Z	3000
Overload	50.0 t
Overload counter	0
Temperature	17.4 °C
Max temperature	18.2 °C
Min. temperature	17.4 °C
Max. weight at	1999-11-30-00:07:42

Display	Description
Model name	e.g.: PR6204/50tC3
Software version	Software version of the load cell
Load cell serial number	Serial number of the load cell
E_{max}	Maximum capacity
n	Max. resolution

Display	Description
Y	Minimum LC verification
Z	Minimum preload signal recurrence
Overload	Weight value above max. load
Overload counter	Number of weight values above max. load The higher the number, the higher the probability of a faulty load cell.
Temperature	Current measured temperature
Max. temperature	Max. measured temperature
Min. temperature	Min. measured temperature
Max. weight value at	Date and time display Time of largest load on load cells
Max. weight value	Display
Firmware checksum	Display of the firmware checksum in HEX format Checksum about the installed firmware version
Config. checksum	Display of the config. checksum in HEX format Checksum about the memory area where the parameters that are relevant for calibration are stored.

- Press  to return to the previous window.

7.19.6 Show Connexx data

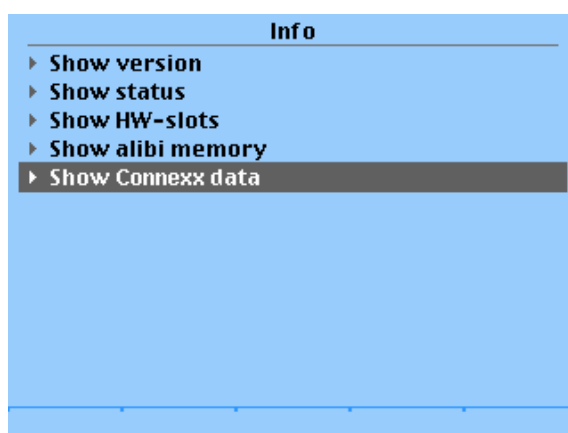

- Select and confirm [Show Connexx data].

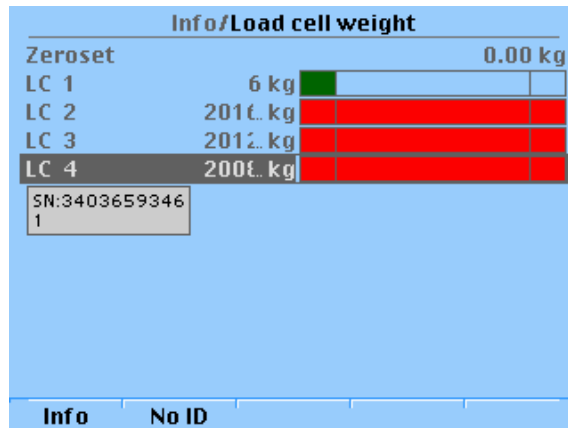

- ▷ An info window appears.

[Zero correction]

The zero correction in use is displayed.

[Communication error count]

The communication errors (timeouts) for the load cells are counted here in ascending order and displayed.

[LC 1...n]

Bar graph display

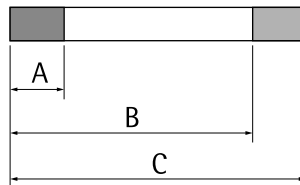

The bar graph shows three areas:

A

Dead load (can be changed by calibration)

B

Maximum capacity E_{max} (max. capacity of load cell) including dead load (load cell, cannot be changed)

C

Max. usable load including dead load (load cell, cannot be changed)

The colors have the following meanings:

Red

Weight value is above maximum capacity (overload) or below $-1/4d$

Green

Weight value is within tolerances

Orange

Weight value is above maximum capacity E_{max} (max. capacity of load cell)

[No ID]

The serial number is hidden.

[Show ID]

The serial number is displayed.

2. Select the desired load cell and press the [Info] softkey.

▷ The load cell data is displayed:

Info/Load cell weight	
Model name	Inteco®/10 t C3
Software version	01.00.00-RC2
Loadcell serial number	25162763
E _{max}	10000 kg
n	3000 e
Y	7000
Z	3000
Overload	16000 kg
Overload counter	0
Max. weight at	2017/03/07 16:44:35
Max. weight value	40187 kg

Display	Description
Model name	e.g.: Inteco®/10 t C3
Software version	Software version of load cell
Load cell serial number	Serial number of load cell
E _{max}	Maximum capacity
n	Max. resolution
Y	Minimum LC verification
Z	Deadload output return
Overload	Weight value above max. usable load
Overload counter	Number of weight values above max. usable load The higher the number, the higher the probability of a faulty load cell.
Temperature	Current measured temperature
Max. temperature	Max. measured temperature
Min. temperature	Min. measured temperature
Max. weight value at	Date and time display Time of largest load on load cells
Max. weight value	Display

3. Press  to return to the previous window.

8 Production

8.1 General notes

All filling functions are only supported by the "EasyFill" application.

NOTICE

Data is lost if the power is interrupted.

There are hard drives for 10 material data records available, which are retained after a power failure.

► It is important to save material data.

8.2 Configuration using the front-panel keys

The production parameters can be configured directly using the front-panel keys.

8.2.1 Configuring production mode using the front-panel keys

You can select between the following production modes:

- Net filling (B1)
- Net Discharge (B4)

Note:

See also Chapter [8.4.1](#).

1. Press .

▷  appears on the display.

2. Press OK.

▷  appears on the display.

The "Cd" calibration menu flashes.

3. Press  multiple times to select "CA 150."

4. Press OK.

▷  appears on the display.

5. Press OK.

▷  (Net filling, B1) appears on the display.

6. Press  if necessary, to select "ne.t d.l." (net discharge, B4).

7. Press "Exit" to exit the Setup menu.



8.2.2 Configuring interaction mode using the front-panel keys

You can select between the following interaction modes:

- Remote control via OPC/ModBus and/or fieldbus
- VNC (Virtual Network Computing)
- Front-panel keys

Note:

See also Chapter [8.4.1.3](#).

1. Press .
 - ▷ **SEtUP** appears on the display.
2. Press OK.
 - ▷ **cd 000** appears on the display.
The "Cd" calibration menu flashes.
3. Press  multiple times to select "IM 151."
4. Press OK.
 - ▷ **IModE** appears on the display.
5. Press OK.
 - ▷ **???** appears on the display.
6. Press  to select the desired mode.
7. Press "Exit" to exit the Setup menu.

8.2.3 Configuring digital inputs and outputs using the front-panel keys

Note:

See also Chapter [8.4.2](#).

Configuring digital inputs

1. Press .
 - ▷ **SEtUP** appears on the display.
2. Press OK.
 - ▷ **cd 000** appears on the display.

The "Cd" calibration menu flashes.

3. Press **↓** multiple times to select "dI 174."
4. Press OK.
 - ▷ **InP 1** appears on the display.
5. Press OK.
 - ▷ **0001** appears on the display.
6. Press the cursor keys to enter the desired SPM address (see Chapter [13.4](#)).
7. Press OK.
 - ▷ **dI 175** appears on the display.
8. Press OK.
 - ▷ **InP 2** appears on the display.
9. Press OK.
 - ▷ **0001** appears on the display.
10. Press the cursor keys to enter the desired SPM address (see Chapter [13.4](#)).
11. Press OK.
 - ▷ **dI 176** appears on the display.
12. Press OK.
 - ▷ **InP 3** appears on the display.
13. Press OK.
 - ▷ **0001** appears on the display.
14. Press the cursor keys to enter the desired SPM address (see Chapter [13.4](#)).
15. Press "Exit" to exit the Setup menu.

Configuring digital outputs
16. Press .
 - ▷ **SEtUP** appears on the display.
17. Press OK.
 - ▷ **Cd 000** appears on the display.

The "Cd" calibration menu flashes.
18. Press **↓** multiple times to select "do 170."
19. Press OK.

- ▷ out 1 appears on the display.
- 20. Press OK.
- ▷ 0001 appears on the display.
- 21. Press the cursor keys to enter the desired SPM address (see Chapter [13.4](#)).
- 22. Press OK.
- ▷ do 171 appears on the display.
- 23. Press OK.
- ▷ out 2 appears on the display.
- 24. Press OK.
- ▷ 0001 appears on the display.
- 25. Press the cursor keys to enter the desired SPM address (see Chapter [13.4](#)).
- 26. Press OK.
- ▷ do 172 appears on the display.
- 27. Press OK.
- ▷ out 3 appears on the display.
- 28. Press OK.
- ▷ 0001 appears on the display.
- 29. Press the cursor keys to enter the desired SPM address (see Chapter [13.4](#)).
- 30. Press "Exit" to exit the Setup menu.

8.2.4 Configuring printout using the front-panel keys

The printout can be configured using the front-panel keys.

Note:

See also Chapter [8.4.4](#).

1. Press .
 - ▷ SEtUP appears on the display.
 2. Press OK.
 - ▷ Cd 000 appears on the display.
- The "Cd" calibration menu flashes.

3. Press **↓** multiple times to select "PC 160."
4. Press OK.
 - ▷ `nuMPrt` (number of printouts) appears on the display.
5. Press OK.
 - ▷ `0000` appears on the display.
6. Press the cursor keys to enter the desired quantity.
7. Press OK.
 - ▷ `SAVE` appears on the display.
8. Press OK.
 - ▷ `YES` appears on the display.
9. Press OK.
 - ▷ `PC 160` appears on the display.
10. Press **↑** to select "PC 161."
11. Press OK.
 - ▷ `SEQnr` (sequence number) appears on the display.
12. Press OK.
 - ▷ `0000` appears on the display.
13. Press the cursor keys to enter the desired number.
14. Press OK.
 - ▷ `SAVE` appears on the display.
15. Press OK.
 - ▷ `YES` appears on the display.
16. Press OK.
 - ▷ `PC 161` appears on the display.
17. Press **↑** to select "PC 162."
18. Press OK.
 - ▷ `PrtMod` (printing mode) appears on the display.
Layout = appl. layout or nICELb = NiceLabelExpress
19. Press OK.

▷ **LAYout** (application layout) appears on the display.

20. Press **↓** if necessary, to select "nICELb" (NiceLabelExpress).

21. Press OK.

▷ **PC 162** appears on the display.

22. Press **↑** to select "PC 163."

23. Press OK.

▷ **Layou 1** (line 1) appears on the display.

24. Press OK.

▷ **nEt** appears on the display.

You can choose from the following:

nEt = net weight, GroSS = gross weight, MAtnAM = material name, nonE = no printout, FF = formfeed, SEq = sequence number, dAtE = date and time, SEtP = set point, tArE = tare weight, nL = CR/LF (carriage return and line feed)

25. Press the cursor keys to select the desired option.

26. Press OK.

▷ **PC 164** appears on the display.

27. Press OK.

▷ **Layou 2** appears on the display.

For "PC 164"... "PC168" (Layout 2...6), follow the same instructions given for "PC 163."

28. Press OK.

▷ **SAVE** appears on the display.

29. Press OK.

▷ **YES** appears on the display.

30. Press OK.

31. Press "Exit" to exit the Setup menu.

8.3 Starting the application

Requirements:

- The "EasyFill" application has been selected; see Chapter 7.18.3.

Procedure:

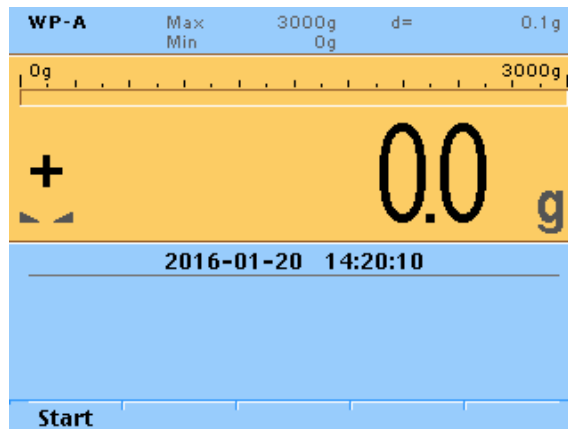

- ▶ Press the [Start] softkey.
 - ▷ The menu opens.

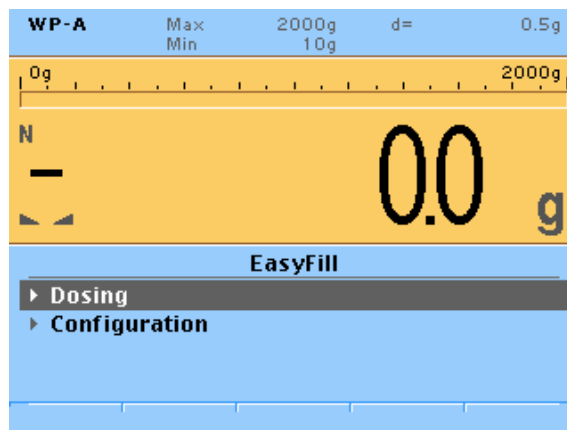

8.4 Configuration via a notebook/PC

8.4.1 Configuring production mode

The following modes are configured under the [Configuration mode] menu item:

- Filling mode
- Interaction mode

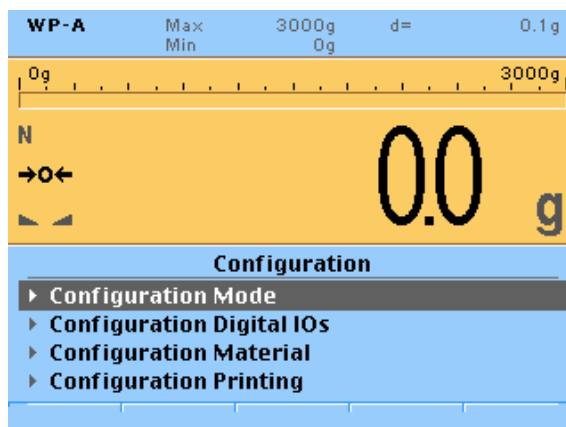

1. Select [Configuration mode] and confirm.

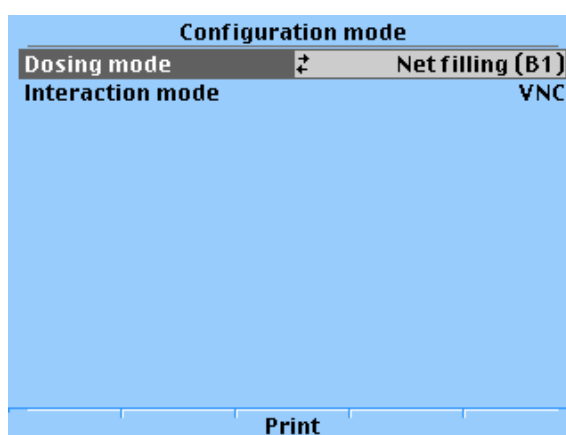

2. Select [Dosing mode] and confirm.
 - ▷ A selection window opens.

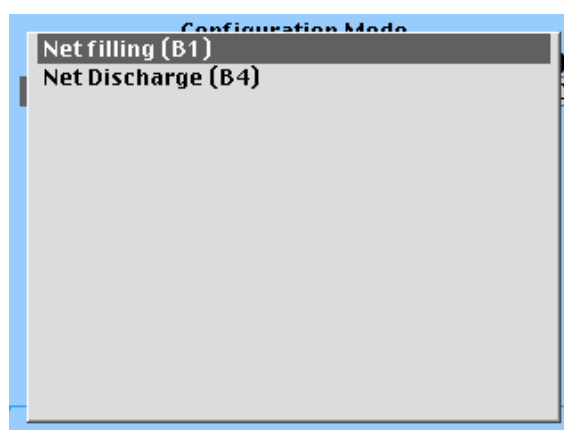

3. Select the desired filling mode (see Chapters [8.4.1.1](#) and [8.4.1.2](#)) and confirm.
4. Select [Interaction mode] and confirm.

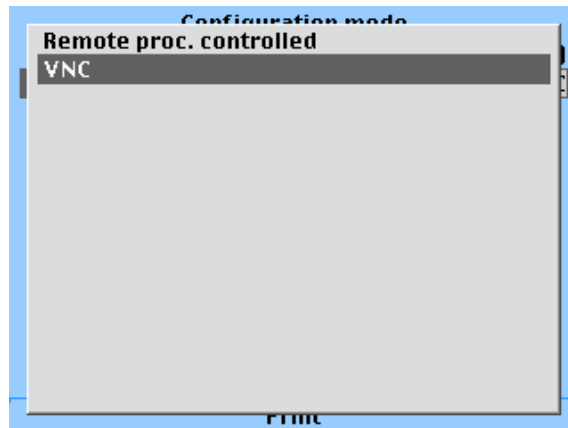

5. Select the desired interaction mode (see Chapter 8.4.1.3) and confirm.
6. Press  to exit the menu.
 - ▷ A prompt window opens.

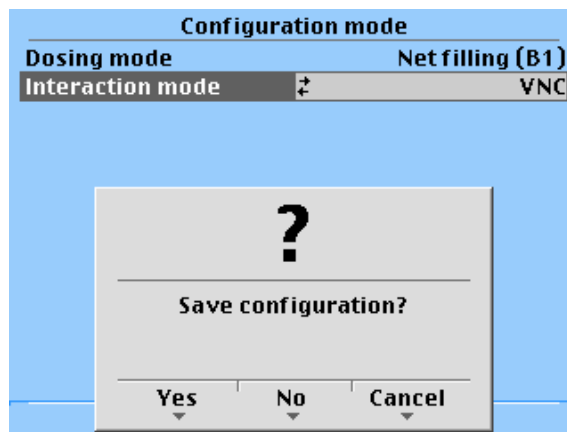

7. Press the [Yes] softkey to save the changes.

8.4.1.1 Net filling (B1)

The scale is tared and then the amount listed in the process line is automatically (Coarse/ Fine) added.

A fix overshoot value is configurated.

Net = gross - tare

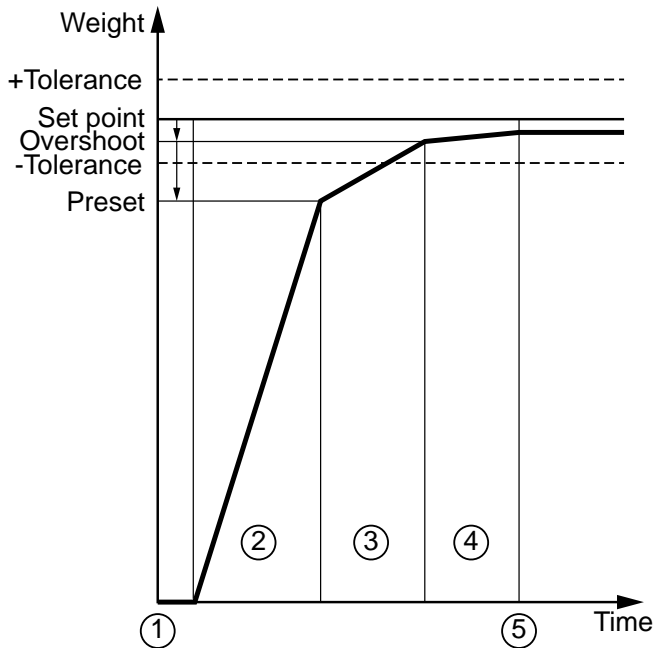
[Net filling] with dosing signals "Coarse/Fine" procedure

- ① Taring:
The current gross weight is saved as tare weight, and the net weight starts at zero.
- ② Coarse:
A coarse flow (coarse and fine) is batched until the preset is reached.
- ③ Fine:
A fine flow is batched until the switch-off point (overshoot) is reached.
- ④ Calming:
Time to wait during which the overshoot is effective and scale vibrations may settle.
- ⑤ Tolerance checking:
The weight is determined and checked against the tolerance values.

8.4.1.2 Net decrease (B4)

The scale is automatically discharged up to the specified value. The other parameters and the process correspond to the [Net filling] mode; see Chapter [8.4.1.1](#).

Net = gross - tare

Tare = gross

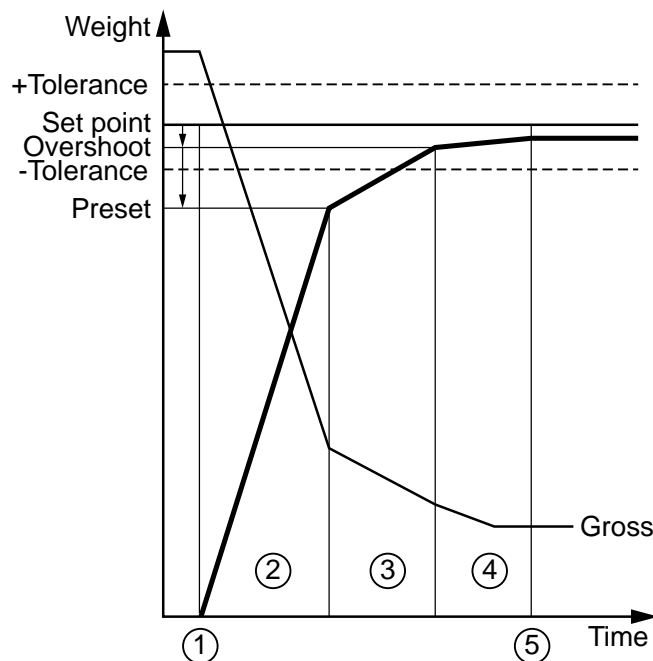
Sequence of [Net decrease] with dosing signals "coarse/fine"

- ① Taring:
The current gross weight is saved as the tare and the net weight starts at zero.
- ② Coarse:
A coarse flow (coarse and fine) is batched until the preset value is reached.
- ③ Fine:
A fine flow is batched until the switch-off point (overshoot) is reached.
- ④ Calming:
Time to wait during which the overshoot is effective and scale vibrations may settle.
- ⑤ Tolerance checking:
The weight is determined and checked against the tolerance values.

8.4.1.3 Interaction mode

You can choose between the following control/operating modes of the device in production:

- [Remote proc. control] via OPC/ModBus and/or fieldbus
- [VNC] (Virtual Network Computing)
- [Front keys]

The following table shows how individual modes are locked when production starts.

Starting production

Mode	Front panel	VNC	Remote control OPC/ModBus	Remote control fieldbus	Digital inputs	Digital outputs
[Remote proc. control]			X	X	X	X
[VNC]		X				X
[Front keys]	X					X

8.4.2 Configuring digital inputs and outputs

SPM addresses are assigned to the digital inputs and outputs under the [Configuration digital IOs] menu item.

Note:

The selected SPM address must be unique within the system.

The SPM addresses for the input and outputs are unchanged after a restart.

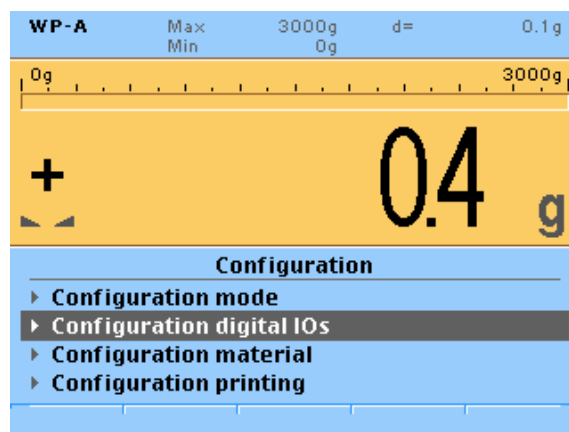

1. Select [Configuration digital IOs] and confirm.

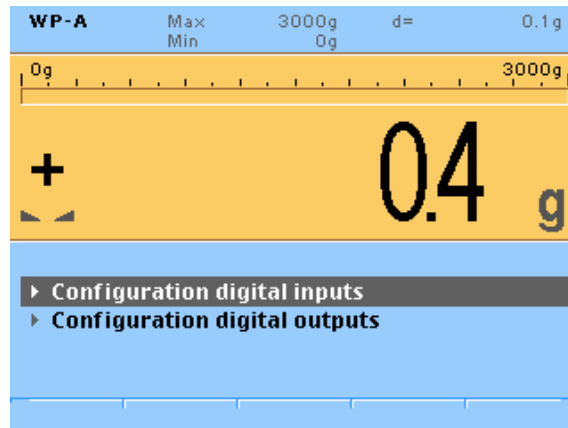

2. Select [Configuration digital inputs] and confirm.
 - ▷ The following window opens:

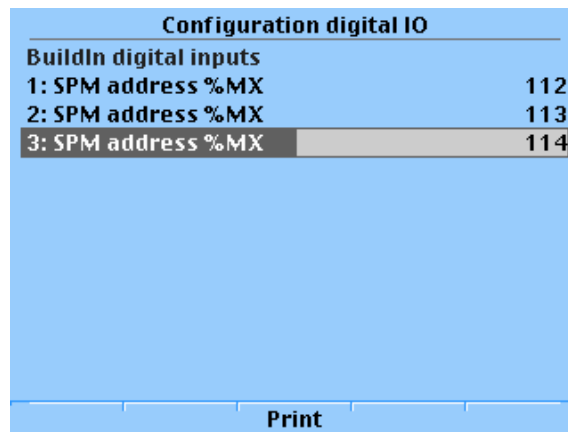

3. Select inputs 1...3. Use the keypad to enter and confirm a corresponding SPM address %MXxxx (see Chapter 13.4).

Note:

The SPM address %MX for an unused digital input = 0.

4. Press  to exit the window and to save the changes.

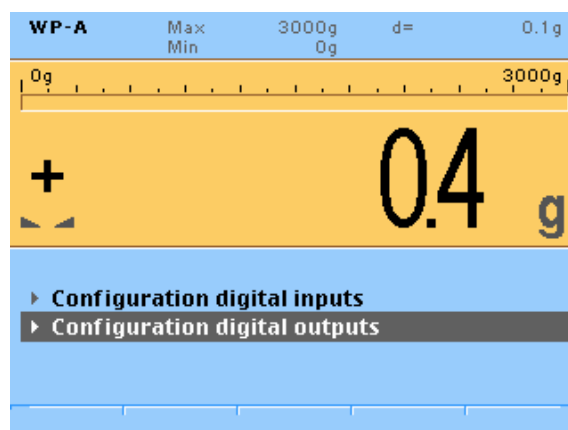

5. Select [Configuration digital outputs] and confirm.

- ▷ The following window opens:

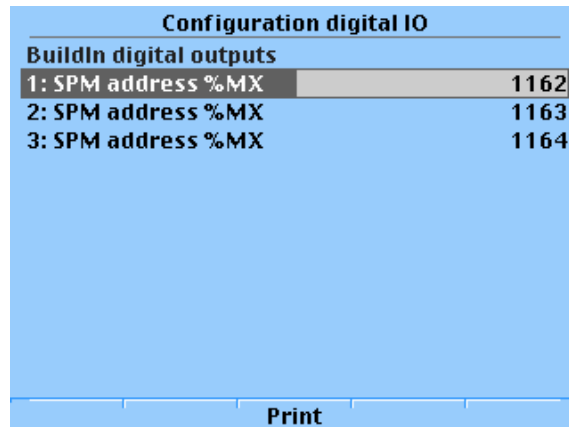

6. Select outputs 1...3. Use the keypad to enter and confirm a corresponding SPM address %MXxxx (see Chapter 13.4).

Note:

The SPM address %MX for an unused digital output = 0.

7. Press Exit to exit the window and to save the changes.

8.4.3 Configuring material

The materials (products) 1...10 are configured under the [Configuration material] menu item.

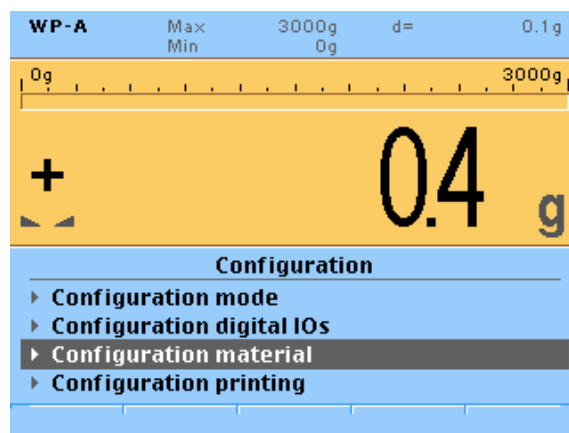

1. Select [Configuration material] and confirm.

- ▷ The configuration window appears.

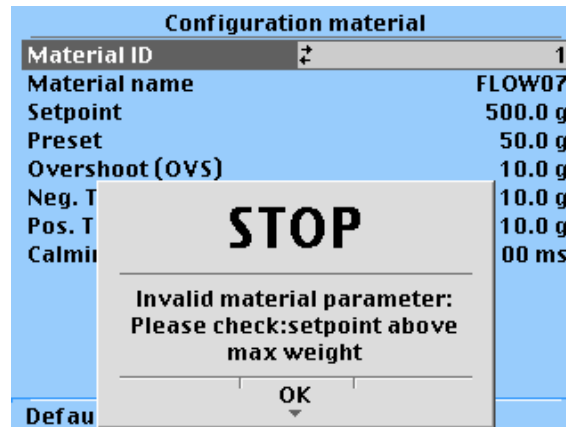

An error message appears if the parameters for the selected material do not match the parameters of the current calibration.

2. Press the [OK] softkey.
 3. Press the [Default] softkey.
- ▷ All values are reset.

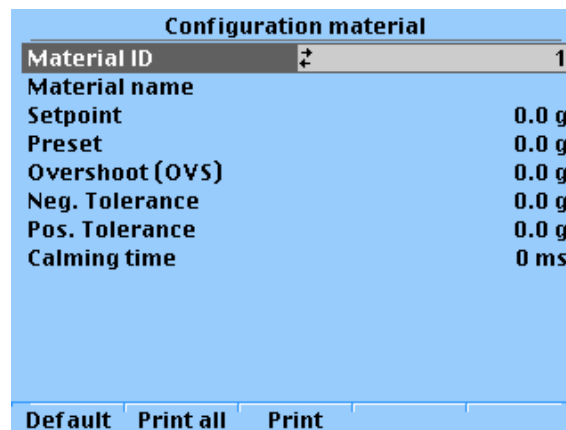

4. Enter the material name and values using the keypad and confirm.

[Material ID]

Material identification 1...10

[Material name]

Input: Material name, max. 18 alphanumeric characters

[Set point]

Input: Set point

[Preset]

Input: Preset point for switching from coarse flow to fine flow

[Overshoot (OVS)]

Input: Material overshoot

[+/- tolerance]

Input: Tolerance above/below set point

[Calming time]

Input: Calming time

Configuration material	
Material ID	1
Material name	SUG01
Set point	250.0 g
Preset	100.0 g
Overshoot (OVS)	20.0 g
- Tolerance	10.0 g
+ Tolerance	10.0 g
Calming time	200 ms

Default Print all Print

5. Configure additional materials if necessary.
6. Use the [Print all] or [Print] softkeys to print the configuration for the 10 materials or for the selected material.
7. Press  to exit the window.
 - ▷ A prompt window opens.

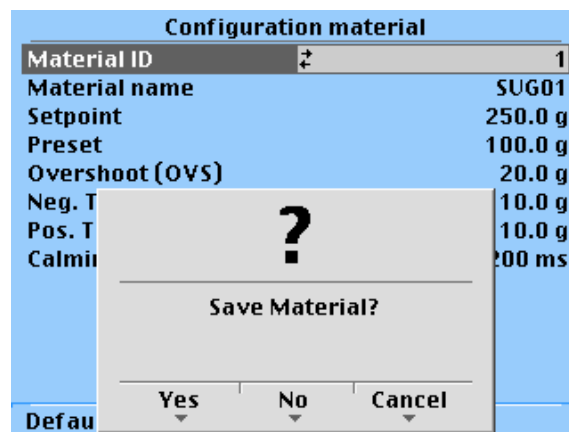

8. Press the [Yes] softkey to save the changes.

8.4.4 Configuring printout

The printout is configured under the [Configuration printing] menu item.

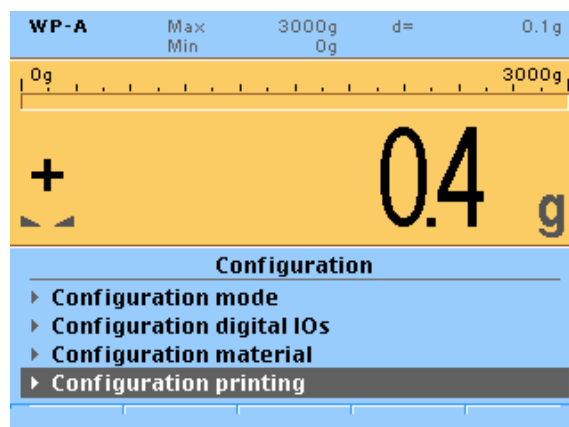

1. Select [Configuration printing] and confirm.
 - ▷ The configuration window appears.

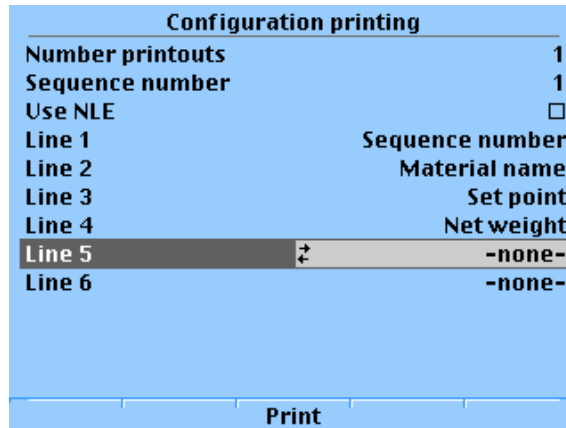

2. Select [Number printouts], enter the number of printouts between 1...10, and confirm.
3. Select [Sequence number], change the sequence number if necessary, and confirm.
4. Select [Use NLE]. Check the box to activate printing with NiceLabelExpress.
5. Select [Line 1]...[Line 6] and confirm.
 - ▷ A selection window opens.

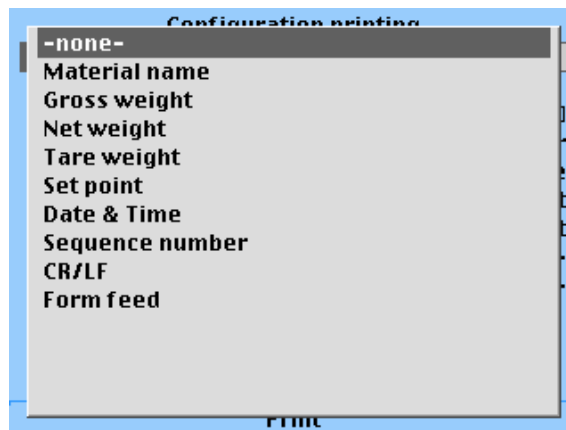

Selection: -none- (no printout; selected if fewer than 6 elements will be printed), Material name, Gross weight, Net weight, Tare weight, Set point, Date & Time (printed in format DD.MM.YYYY HH:MM:SS), Sequence number (counter for individual print orders, max. 6 digits, #000001 comes after #999999), CR/LF (carriage return and line feed), Form feed

6. Confirm selection.
7. Press the [Print] softkey to print out the configuration if necessary.
8. Press  to exit the window.

- ▷ A prompt window opens.

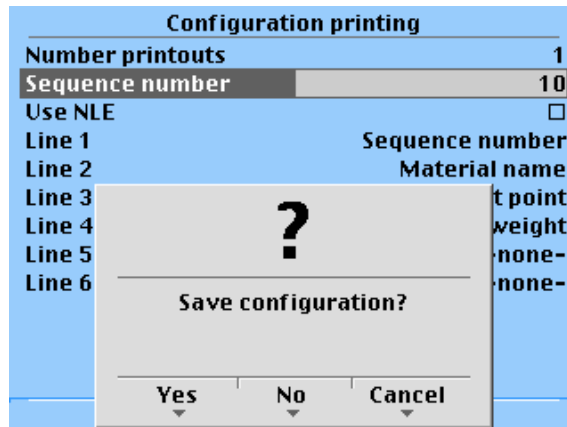

9. Press the [Yes] softkey to save the changes.

8.5 Filling

Requirements:

- Weighing point is calibrated.
- Production mode is configured; see Chapter [8.4.1](#).
- Digital inputs and outputs are configured (optional); see Chapter [8.4.2](#).
- Material (product) is configured; see Chapter [8.4.3](#).
- Printout is configured (optional); see Chapter [8.4.4](#).

Example:

- Filling mode: Net filling (B1)
- Interaction mode: VNC
- Digital outputs 1, 2: SPM-Adresse %MX 1162 (coarse)/1163 (fine)
- Material ID: 2

Procedure:

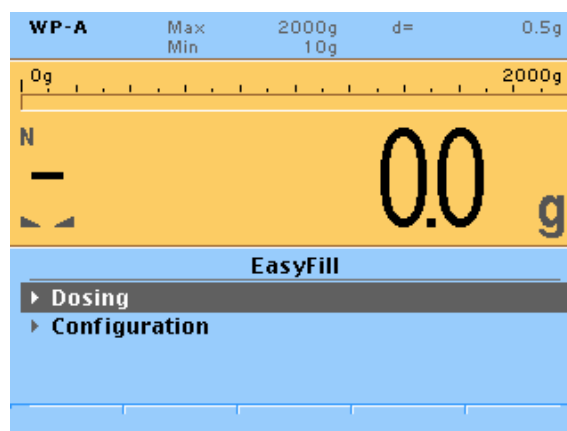

1. Select [Dosing] and confirm.

- ▷ The production window appears.

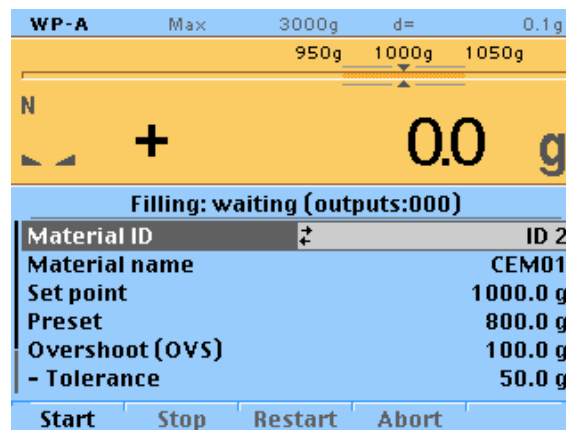



2. Select material ID [ID 2].
3. Press the [Start] softkey.
 - ▷ The material (product) is filled.
Press the [Stop] softkey to stop the process.
You can then press the [Restart] softkey to restart the process.
4. Once the set point is reached, the [Start] softkey can be pressed again.
5. Press  2x to exit the application.

9 Extended functions

9.1 Hardware test



9.1.1 Display test



1. Press .
2. Press  2x.
 - ▷ `dSP . tSt .` appears on the display.
3. Press OK.
 - ▷ Operate all display elements.

When no key has been pressed for 5 seconds, the test ends automatically.

The device goes back to the weight display.

9.1.2 Front-panel key test

1. Press and hold  and also press .
 - ▷ `0.0.0.0.0.0.0.`

A number is displayed for each key. The number increases by 1 each time a key is pressed.
2. For example, press .
 - ▷ `0.0.0.1.0.0.` appears on the display.
3. For example, press  and  at the same time.
 - ▷ `-8023-` appears on the display.

When no key has been pressed for 5 seconds, the test ends automatically.

The device goes back to the weight display.

9.1.3 Serial interfaces

9.1.3.1 RS-232 interface

Open the menu with  - [HW-Slots].

Info/HW-Slots		
▶	Builtin	RS232
▶	Slot 1	-empty-
▶	Slot 2	PR5510/07 analog I/O
▶	Builtin	digital I/O
▶	Slot 4	PR1721/31 Profibus-DP
▶	Builtin	Scale-ADC

1. Plug the test connector (see Chapter [18.2](#)) into the RS-232 interface.
2. Select the interface and confirm.
 - ▷ The results are displayed:
 - passed = ok
 - failed (no data) = error

Info/HW-Slots	
Builtin	RS232
RS232 Test:	
TxD-RxD	passed
RTS-CTS	passed
Again	

3. Press  to return to the previous window.

9.1.4 Inputs and outputs

There are different modes for testing the analog and digital inputs and outputs:

- Test mode "Monitor"
- Test mode "Internal"
- Test mode "External"

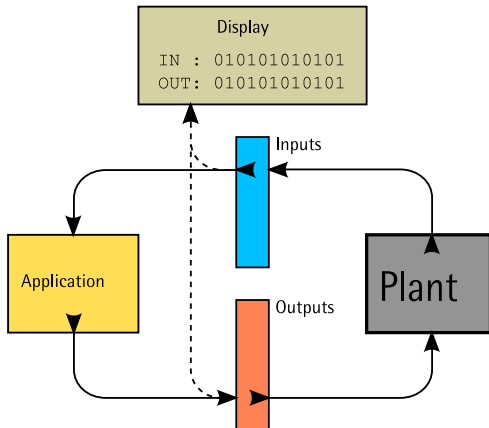
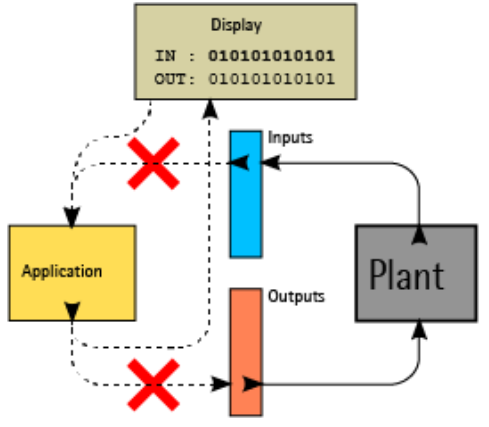
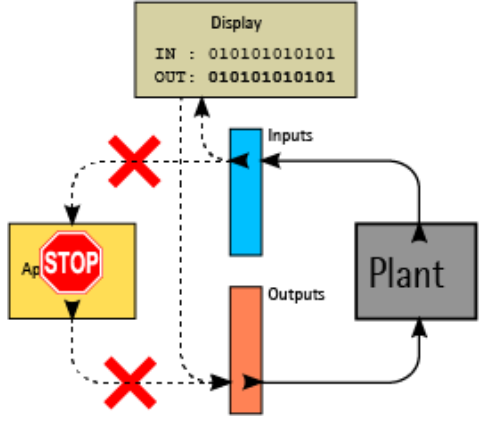
Test mode	Description
<p data-bbox="389 300 507 333">"Monitor"</p> 	<p data-bbox="916 300 1046 333">Active PLC:</p> <ul data-bbox="916 338 1412 595" style="list-style-type: none"> - The physical inputs of the system (plant) are directed to the PLC (application). - The physical outputs of the system (plant) are set by the PLC (application). - The physical inputs and outputs are displayed (display).
<p data-bbox="389 786 507 819">"Internal"</p> 	<p data-bbox="916 786 1046 819">Active PLC:</p> <ul data-bbox="916 824 1412 1048" style="list-style-type: none"> - The entered input values are sent to the PLC (application). - The PLC output is displayed (display). - The physical inputs and outputs of the system (plant) are deactivated and passive (in secured condition).
<p data-bbox="389 1272 507 1305">"External"</p> 	<p data-bbox="916 1272 1114 1305">Deactivated PLC:</p> <ul data-bbox="916 1310 1412 1485" style="list-style-type: none"> - The physical inputs are displayed (display). - Output values can be entered. - The given output values are set on the physical outputs.

9.1.4.1 Adapting the analog output

The output current can be adapted in small ranges. This is required, if small deviations from the nominal value occur in a connected PLC.

Open the menu with  - [HW-Slots].

Info/HW-Slots		
▶ Slot 1	Builtin	RS232
		-empty-
▶ Slot 2	PR5510/07	analog I/O
▶	Builtin	digital I/O
▶ Slot 4	PR1721/31	Profibus-DP
▶	Builtin	Scale-ADC

1. Select and confirm the analog output.

Info/HW-Slots		
PR5510/07	analog I/O	2
In use by PLC task		2
Analog output		0.000 mA
counts		12 cnt
Analog input 1		3
		0.100 %
Analog input 2		3
		0.100 %
Analog input 3		3
		0.100 %
Analog input 4		3
		0.100 %

Stop PLC | Stop I/O | Adjust | Reset

2. Press the [Adjust] softkey.
 - ▷ The window for the 1st value opens.

Info/HW-Slots/Adjust Analog Output	
Output	4.000 mA
Measured	3.925 mA

3. Enter and confirm e.g. the value for 4 mA measured by the connected PLC under [Measured].

- ▷ The window for the 2nd value opens.

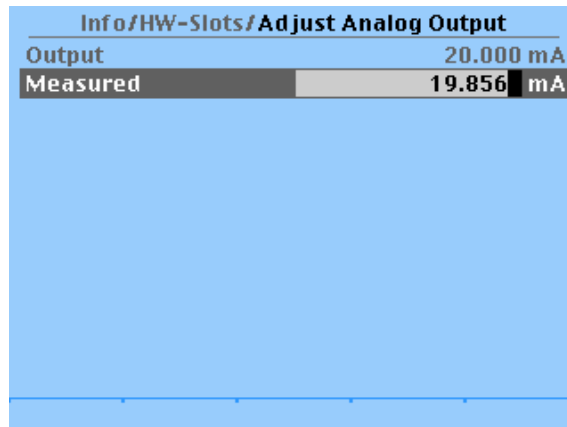

4. Enter and confirm e.g. the value for 20 mA measured by the connected PLC under [Measured].

- ▷ A prompt window opens.

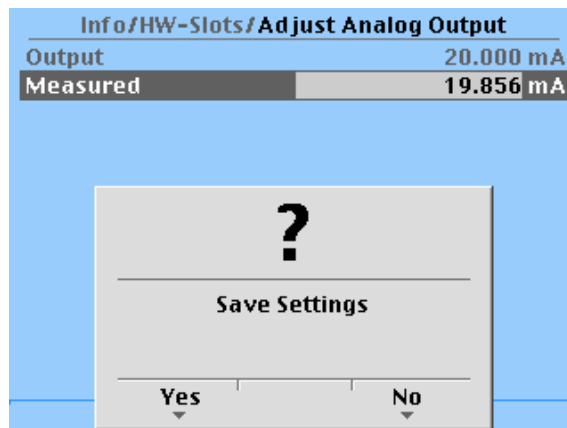

5. Press the [Yes] softkey to save the settings.

If applicable, press the [No] softkey to keep the original values.

- ▷ The following window opens:

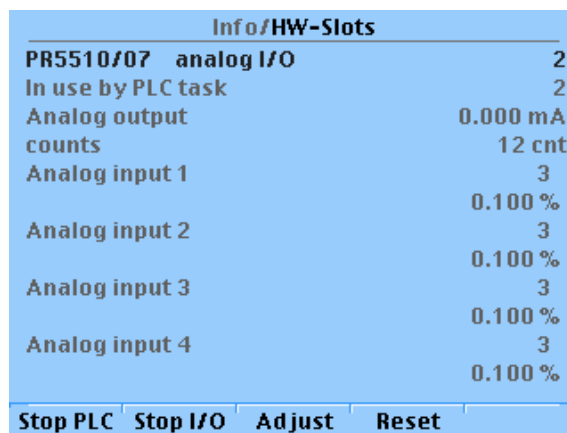

6. Press the [Reset] softkey to reset to the factory settings (4 mA and 20 mA).

- ▷ A prompt window opens.

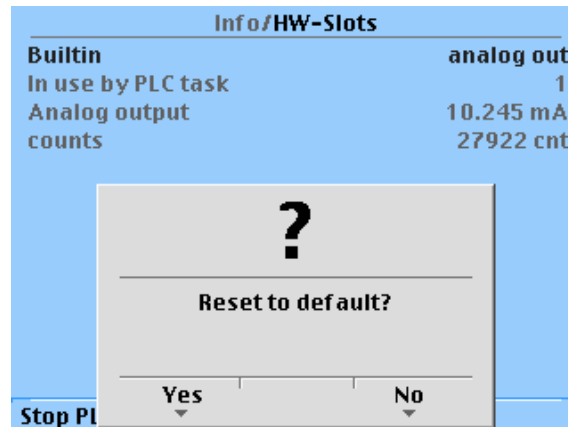

7. Press the [Yes] softkey to reset to the factory settings.
If applicable, press the [No] softkey to keep the entered values.
8. Press  to return to the previous window.

9.1.4.2 Digital inputs and outputs

Open the menu with  - [HW-Slots].

1. Select and confirm the appropriate line.
 - ▷ The following window opens.

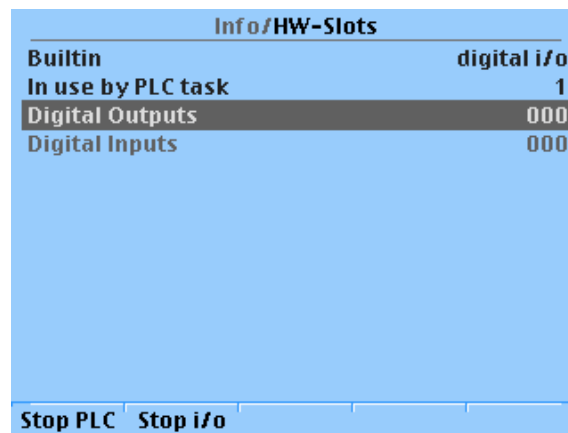

The "Monitor" test mode is active.

2. Press the [Stop i/o] softkey.

Info/HW-Slots	
Builtin	digital i/o
In use by PLC task	1
Digital Outputs	000
Digital Inputs	001

Stop PLC Run i/o

3. Enter the input values using the keyboard and confirm.

Input: 0 and 1 (e.g.: 111; 001)

- ▷ An info window is shown briefly. The "Internal" test mode is active.

The inputs are simulated to test the functionality of the PLC (application); see Chapter [9.1.4](#).

4. Press  to return to the previous window.
5. Press the [Stop PLC] softkey.

An info window is shown briefly.

Info/HW-Slots	
Builtin	digital i/o
In use by PLC task	0
Digital Outputs	100
Digital Inputs	000

Run PLC Stop i/o

6. Enter the output values using the keyboard and confirm.

Input: 0 and 1 (e.g.: 111; 100)

- ▷ An info window is shown briefly. The "External" test mode is active.

The physical inputs and outputs (hardware) are tested without the involvement of the PLC (application) (see Chapter [9.1.4](#)).

7. Press  to return to the previous window.

9.2 Functions via the WEB site

9.2.1 General information

If the device is connected to the network, it can be displayed e.g. in the "Windows" operating system under "Network".

Double-click the device icon to open the WEB menu (in English only) in the available Internet browser (see also Chapter [7.12](#)).

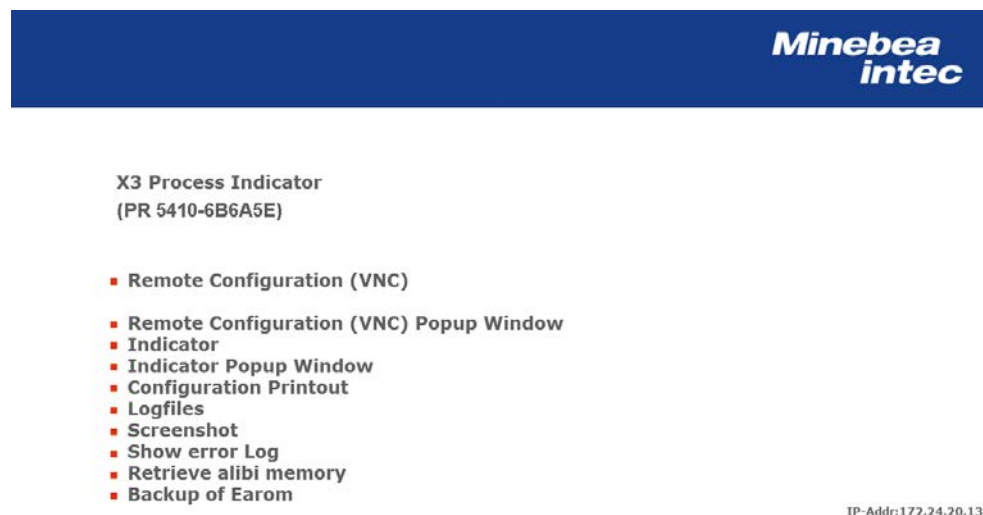

The device name entered under -[Network parameter]- [Hostname] is shown under the header in brackets.

[Remote Configuration (VNC)]

Operation using the VNC program, see Chapter [7.11](#).

[Remote Configuration (VNC) Pop-up Window]

Operation using the VNC program, see Chapter [7.11](#).

[Indicator]

Displays the weighing point in a status window, see Chapter [9.2.2](#).

[Indicator pop-up window]

Displays the weighing point in a status window, see Chapter [9.2.2](#).

[Configuration printout]

Display configuration printout, saving and printing out as a text file, see Chapter [9.2.3](#).

[Log files]

Display logfiles, saving and printing out as a text file, see Chapter [9.2.4](#).

[Screenshot]

Displaying, saving and printing a screenshot, see Chapter [9.2.5](#).

[Show error Log]

Display and save the error logs, see Chapter [9.2.6](#).

[Retrieve alibi memory]

This alibi memory can be used to save approx. 80,000 entries and to retrieve them, if necessary; see [9.2.7](#).

[Backup of Earom]

Saving and restoring the configuration and calibration data, see Chapter [9.2.8.1](#).

9.2.2 Displaying weighing points in a table

1. Click on the [Indicator] menu item in the WEB menu.
 - ▷ A status window opens in which the weight of the weighing point is displayed with unit and the status symbols.



2. Click on the  symbol in the Internet browser to return to the WEB menu.
3. Click on the [Indicator Pop-up Window] menu item in the WEB menu.
 - ▷ A separate status window opens in which the weight of the weighing point is displayed with unit and the status symbols.

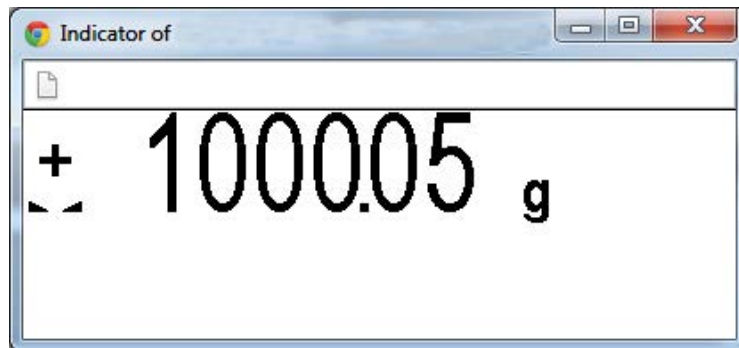



4. Click on the  symbol to return to the WEB menu.

9.2.3 Configuration printout

With the [Configuration Printout] menu item the configuration of the device of the device can be displayed, saved and printed out.

Note:

The configuration printout can be activated via  and  (clicked one after the other); see Chapter [7.18.4](#).

1. Click the [Configuration Printout] menu item in the WEB menu.
 - ▷ The configuration of the device is shown on the display.
2. Click on [File]- [Save as...].
3. Create and open the required directory e.g. on the notebook.
4. Click on [Save] to save the text file in the relevant directory.
5. Click on [Print]- [File...].
6. Select the connected printer and click [Print].
7. Click on the  symbol in the Internet browser to return to the WEB menu.

9.2.4 Log files

With the [Logfiles] menu item the logfiles of the device can be displayed, saved and printed out.

1. Click the [Logfiles] menu item in the WEB menu.
 - ▷ A list of logfiles is shown on the display.

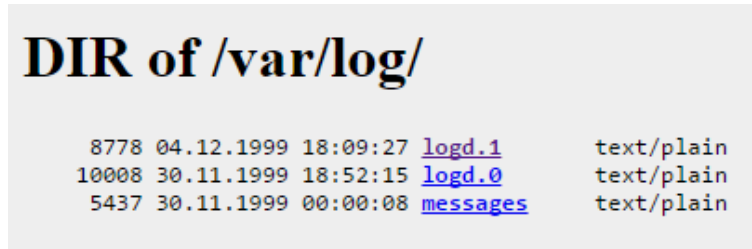

2. Click on the desired file.

```

<46>Nov 30 00:00:03 syslogd started:
<45>Nov 30 00:00:03 klogd: (19991030T000003443) klogd running
<12>Nov 30 00:00:03 klogd: (19991030T000003559) Linux version 2.6.10-uc0 (software@sartorius.com) (gcc version 3.4.0) 260208[M1] 2015-04-10-10:47:24
<14>Nov 30 00:00:03 klogd: (19991030T000003564) ^O^M
<12>Nov 30 00:00:03 klogd: (19991030T000003569)
<12>Nov 30 00:00:03 klogd: (19991030T000003574) uClinux/COLDFIRE(m5270/5271/5274/5275)
<14>Nov 30 00:00:03 klogd: (19991030T000003579) COLDFIRE port done by Greg Ungerer, greg@snaggear.com
<14>Nov 30 00:00:03 klogd: (19991030T000003584) Flat model support (C) 1998,1999 Kenneth Albanowski, D. Jeff Dionne
<15>Nov 30 00:00:03 klogd: (19991030T000003589) On node 0 totalpages: 4096
<15>Nov 30 00:00:03 klogd: (19991030T000003594) DMA zone: 0 pages, LIFO batch:1
<15>Nov 30 00:00:03 klogd: (19991030T000003599) Normal zone: 4096 pages, LIFO batch:1
<15>Nov 30 00:00:03 klogd: (19991030T000003604) Highmem zone: 0 pages, LIFO batch:1
<12>Nov 30 00:00:03 klogd: (19991030T000003610) Built 1 zonelists
<12>Nov 30 00:00:03 klogd: (19991030T000003615) Kernel command line: console=ttyS2,19200
<12>Nov 30 00:00:03 klogd: (19991030T000003620) PID hash table entries: 128 (order: 7, 2048 bytes)
<12>Nov 30 00:00:03 klogd: (19991030T000003625) Dentry cache hash table entries: 4096 (order: 2, 16384 bytes)
<12>Nov 30 00:00:03 klogd: (19991030T000003630) Inode-cache hash table entries: 2048 (order: 1, 8192 bytes)
<14>Nov 30 00:00:03 klogd: (19991030T000003636) Memory available: 15136k/16384k RAM, 0k/0k ROM (337k kernel code, 153k data)
<15>Nov 30 00:00:03 klogd: (19991030T000003641) Calibrating delay loop... 65.74 BogoMIPS (lpj=1644352)
<12>Nov 30 00:00:03 klogd: (19991030T000003646) Mount-cache hash table entries: 512 (order: 0, 4096 bytes)
<14>Nov 30 00:00:03 klogd: (19991030T000003651) NET: Registered protocol family 16
<12>Nov 30 00:00:03 klogd: (19991030T000003656) Sartorius EventFlags installed
<12>Nov 30 00:00:03 klogd: (19991030T000003661) Sartorius QSPI device driver installed
<12>Nov 30 00:00:03 klogd: (19991030T000003666) Sartorius HMS Anybus-CC device driver installed
<12>Nov 30 00:00:03 klogd: (19991030T000003671) Sartorius Combi keyboard registered
<12>Nov 30 00:00:03 klogd: (19991030T000003676) Sartorius XBPI driver installed
<12>Nov 30 00:00:03 klogd: (19991030T000003681) ColdFire internal UART serial driver version 1.00
<12>Nov 30 00:00:03 klogd: (19991030T000003686) ttyS1 at 0x40000240 (irq = 78) is a builtin ColdFire UART
<12>Nov 30 00:00:03 klogd: (19991030T000003692) ttyS2 at 0x40000280 (irq = 79) is a builtin ColdFire UART
<14>Nov 30 00:00:03 klogd: (19991030T000003697) io scheduler noop registered
<14>Nov 30 00:00:03 klogd: (19991030T000003702) io scheduler deadline registered
<12>Nov 30 00:00:03 klogd: (19991030T000003707) eth0: FEC ENET Version 0.2, 00:90:6c:31:1f:48
<12>Nov 30 00:00:03 klogd: (19991030T000003712) fec: PHY @ 0x1, ID 0x00221619 -- K58721B1L
<14>Nov 30 00:00:03 klogd: (19991030T000003717) elevator: using deadline as default io scheduler
<14>Nov 30 00:00:03 klogd: (19991030T000003722) mtd0 00000000 00020000 "PR5220-Bios 04.00.02-IBC-RC2.260210[M3-u1
<14>Nov 30 00:00:03 klogd: (19991030T000003992) mtd1 00020000 0038AC10 "PR5220-Firm 04.00.02-IBC-RC2.260210[M5] 2
<14>Nov 30 00:00:03 klogd: (19991030T000003998) mtd2 003B0000 00001410 "PR5220-Appl-PR5220-Application 01.00.06.2
<14>Nov 30 00:00:04 klogd: (19991030T000004003) mtd3 003C0000 0000C810 "PR5220-Appl-IBC 01.00.00.2 2015-04-29-11:
<14>Nov 30 00:00:04 klogd: (19991030T000004008) bootdev=1
<13>Nov 30 00:00:04 klogd: (19991030T000004013) Flash device: 800000 at f0000000
<13>Nov 30 00:00:04 klogd: (19991030T000004018) Creating 4 MTD partitions on "FLASH":
    
```

Zurück	Alt+Linkspfeil
Vorwärts	Alt+Rechtspfeil
Neu laden	Strg+R
Speichern unter...	Strg+S
Drucken...	Strg+P
Übersetzen in Deutsch	
Seitenquelltext anzeigen	Strg+U
Seiteninfo anzeigen	
Element untersuchen	Strg+Umschalt+I

3. Click on [Save as].
4. Create and open the required directory e.g. on the notebook.
5. Click on [Save] to save the text file in the relevant directory.
6. Press the right mouse button.

```
<46>Nov 30 00:00:03 syslogd started:
<45>Nov 30 00:00:03 klogd: (199910307000003443) klogd running
<12>Nov 30 00:00:03 klogd: (199910307000003559) Linux version 2.6.10-uc0 (software@sartorius.com) (gcc version 3.4.0) 260208[HS] 2015-04-10-10:47:24
<14>Nov 30 00:00:03 klogd: (199910307000003564) -qPM
<12>Nov 30 00:00:03 klogd: (199910307000003569)
<12>Nov 30 00:00:03 klogd: (199910307000003574) uClinux/COLDFIRE(m5270/5271/5274/5275)
<14>Nov 30 00:00:03 klogd: (199910307000003579) COLDFIRE port done by Greg Ungerer, gerg@snapgear.com
<14>Nov 30 00:00:03 klogd: (199910307000003584) Flat model support: (C) 1996,1999 Kenneth Albanowski, D. Jeff Dionne
<15>Nov 30 00:00:03 klogd: (199910307000003594) On node 0 totalpages: 4096
<15>Nov 30 00:00:03 klogd: (199910307000003594) DMA zone: 0 pages, LIFO batch:1
<15>Nov 30 00:00:03 klogd: (199910307000003599) Normal zone: 4096 pages, LIFO batch:1
<15>Nov 30 00:00:03 klogd: (199910307000003604) HighMem zone: 0 pages, LIFO batch:1
<12>Nov 30 00:00:03 klogd: (199910307000003610) Built 1 zonelists
<12>Nov 30 00:00:03 klogd: (199910307000003615) Kernel command line: console=ttyS2,19200
<12>Nov 30 00:00:03 klogd: (199910307000003620) PID hash table entries: 128 (order: 7, 2048 bytes)
<12>Nov 30 00:00:03 klogd: (199910307000003625) Dentry cache hash table entries: 4096 (order: 2, 16384 bytes)
<12>Nov 30 00:00:03 klogd: (199910307000003630) Inode-cache hash table entries: 2048 (order: 1, 8192 bytes)
<14>Nov 30 00:00:03 klogd: (199910307000003636) Memory available: 15136k/16384k RAM, 0k/0k ROM (837k kernel code, 153k data)
<15>Nov 30 00:00:03 klogd: (199910307000003641) Calibrating delay loop... 65.74 BogoMIPS (lpj=164352)
<12>Nov 30 00:00:03 klogd: (199910307000003646) Mount-cache hash table entries: 512 (order: 0, 4096 bytes)
<14>Nov 30 00:00:03 klogd: (199910307000003651) NET: Registered protocol family 16
<12>Nov 30 00:00:03 klogd: (199910307000003656) Sartorius EventFlags installed
<12>Nov 30 00:00:03 klogd: (199910307000003661) Sartorius QSPI device driver installed
<12>Nov 30 00:00:03 klogd: (199910307000003666) Sartorius HMS Anybus-CC device driver installed
<12>Nov 30 00:00:03 klogd: (199910307000003671) Sartorius Combix Keyboard registered
<12>Nov 30 00:00:03 klogd: (199910307000003676) Sartorius XMP1 driver installed
<12>Nov 30 00:00:03 klogd: (199910307000003681) ColdFire internal UART serial driver version 1.00
<12>Nov 30 00:00:03 klogd: (199910307000003686) ttyS1 at 0x40000240 (irq = 78) is a builtin ColdFire UART
<12>Nov 30 00:00:03 klogd: (199910307000003692) ttyS2 at 0x40000280 (irq = 79) is a builtin ColdFire UART
<14>Nov 30 00:00:03 klogd: (199910307000003702) io scheduler noop registered
<12>Nov 30 00:00:03 klogd: (199910307000003707) eth0: FEC ENET version 0.2, 00:90:6c:31:1f:48
<12>Nov 30 00:00:03 klogd: (199910307000003712) fec: PHY @ 0x1, ID 0x00212619 -- K587218L
<14>Nov 30 00:00:03 klogd: (199910307000003717) elevator: using deadline as default io scheduler
<14>Nov 30 00:00:03 klogd: (199910307000003722) mtd0 00000000 00020000 "PR5220-Bios 04.00.02-IBC-RC2.260210[HS-u1] 2015-07-15"
<14>Nov 30 00:00:03 klogd: (199910307000003992) mtd1 00020000 00364C10 "PR5220-Firm 04.00.02-IBC-RC2.260210[HS] 2015-06-29-15"
<14>Nov 30 00:00:03 klogd: (199910307000003998) mtd2 00300000 00001410 "PR5220-App1-PR5220-Application 01.00.06 2010-10-15-15"
<14>Nov 30 00:00:03 klogd: (199910307000004003) mtd3 003C0000 0000C810 "PR5220-App1-IBC 01.00.00.2 2015-04-29-11:14:43"
<14>Nov 30 00:00:04 klogd: (199910307000004008) bootdev=1
<13>Nov 30 00:00:04 klogd: (199910307000004013) flash device: 800000 at f0000000
<13>Nov 30 00:00:04 klogd: (199910307000004018) Creating 4 MTD partitions on "FLASH":
<13>Nov 30 00:00:04 klogd: (199910307000004024) 0x00000000-0x00020000 : "PR5220-Bios 04.00.02-IBC-RC2.260210[HS-u1] 2015-07-15"
<13>Nov 30 00:00:04 klogd: (199910307000004029) 0x00020000-0x003aa010 : "PR5220-Firm 04.00.02-IBC-RC2.260210[HS] 2015-06-29-15"
<13>Nov 30 00:00:04 klogd: (199910307000004034) 0x003aa010-0x003b1410 : "PR5220-App1-PR5220-Application 01.00.06 2010-10-15-15"
<13>Nov 30 00:00:04 klogd: (199910307000004040) 0x003b1410-0x003cc810 : "PR5220-App1-IBC 01.00.00.2 2015-04-29-11:14:43"
<13>Nov 30 00:00:04 klogd: (199910307000004045) flash device initialized
```

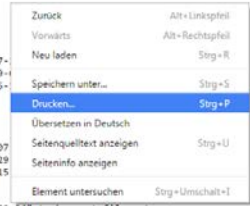

7. Click on [Print...].
8. Select the connected printer and click [Print].
9. Click on the  symbol in the Internet browser to return to the WEB menu.

9.2.5 Screenshots

With the [Screenshot] menu item a screenshot of the device can be displayed, saved and printed out.

1. Click on the [Screenshot] menu item in the WEB menu.
 - ▷ The current device display is shown as a screenshot.
2. Press the right mouse button.
3. Click on [Save image as...].
4. Create and open the required directory e.g. on the notebook.
5. Click on [Save] to save the graphic file in the relevant directory.
6. Press the right mouse button.
7. Click on [Print...].
8. Select the connected printer and click [Print].
9. Click on the  symbol in the Internet browser to return to the WEB menu.

9.2.6 Error log

With the [Show error Log] menu item the error log of the device can be displayed, saved and printed out.

1. Click the [Show error Log] menu item in the WEB menu.
 - The error log of the device is shown on the display.
2. Press the right mouse button.

Record	Type	Message
1	RESET	RCM:Watchdog Reset

Zurück	Alt+Linkspfeil
Vorwärts	Alt+Rechtspfeil
Neu laden	Strg+R
Speichern unter...	Strg+S
Drucken...	Strg+P
Übersetzen in Deutsch	
Seitenquelltext anzeigen	Strg+U
Seiteninfo anzeigen	
Element untersuchen	Strg+Umschalt+I

3. Click on [Save as].
4. Create and open the required directory e.g. on the notebook.
5. Click on [Save] to save the text file in the relevant directory.
6. Press the right mouse button.

Record	Type	Message
1	RESET	RCM:Watchdog Reset

Zurück	Alt+Linkspfeil
Vorwärts	Alt+Rechtspfeil
Neu laden	Strg+R
Speichern unter...	Strg+S
Drucken...	Strg+P
Übersetzen in Deutsch	
Seitenquelltext anzeigen	Strg+U
Seiteninfo anzeigen	
Element untersuchen	Strg+Umschalt+I

7. Click on [Print...].
8. Select the connected printer and click [Print].
9. Click on the  symbol in the Internet browser to return to the WEB menu.

9.2.7 Alibi memory

9.2.7.1 General information

The device is equipped with an alibi memory for approx. 80,000 entries. Once this number has been reached, the oldest entries are overwritten.

No license is required to use the alibi memory.

Each time a print command is executed, a data record with a sequence number is automatically stored, which can consist of up to 3 entries (gross, net, and tare).

Each entry contains:

Sequence number	1–999999
Date	YYYY/MM/DD
Time	hh:mm:ss
Scale address	Always A
Weight type	G = gross, N = net, T = tare, PT = preset tare
Weight with unit	

Depending on the configuration, the gross and/or net and/or tare weight are saved

(using the front-panel keys: `OP 063` see Chapter [7.5.1](#)).

To view the data records using the VNC program, see Chapter [7.19.4](#).

To view the data records using the front-panel keys, see Chapter [7.6.1](#).

The alibi memory can be completely deleted, as long as the CAL switch is open, using the front-panel keys only (see Chapter [7.6.2](#)).

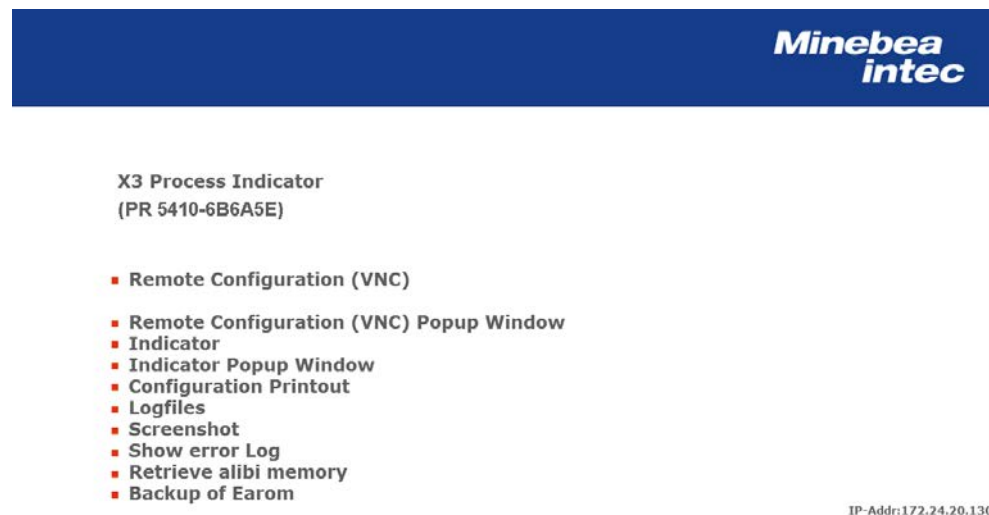

1. Click on the [Retrieve alibi memory] menu item in the WEB menu.

▷ The CSV file appears as an icon at the bottom of the screen.

2. Click on the icon.

▷ The file automatically opens, e.g., in Microsoft Excel.

Commas are used in the CSV file to separate the individual elements of an entry.

3. Carry out a conversion in Microsoft Excel to see only one element per column. The sequence number is placed in front of a consecutive line number.

Example:

Data record as CSV file

```
Line, Seq.No., Date, Time, WP, Type, Weight
55, 13, 2007-05-22, 16:26:05, A, B, "12.450 kg"
56, 13, 2007-05-22, 16:26:05, A, N, "10.400 kg"
57, 13, 2007-05-22, 16:26:05, A, T, "2.050 kg"
```

After conversion in Microsoft Excel

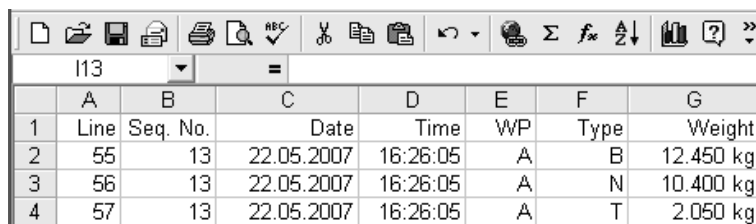

	A	B	C	D	E	F	G
1	Line	Seq. No.	Date	Time	WP	Type	Weight
2	55	13	22.05.2007	16:26:05	A	B	12.450 kg
3	56	13	22.05.2007	16:26:05	A	N	10.400 kg
4	57	13	22.05.2007	16:26:05	A	T	2.050 kg

Note:

Microsoft Excel can import maximum 65,536 lines.

If this limit is exceeded, the CSV file must be split before processing it in Excel.

4. The file can then be saved and printed.
5. Click on the  symbol in the Internet browser to return to the WEB menu.

9.2.7.2 Saving an alibi data record**Requirements:**

In menu -[Operating parameter][Use alibimemory], the [Gross, Net, Tare] parameter is selected.

Procedure:

After a weighing operation, press the  key or complete filling.

The weight data is written into the alibi memory.

Example:

Operating sequence; see also Chapter [13.4](#)

1	Write request	X120	Start printing and save data record
1a	Wait	X120	= 0
1b	Wait	X49	(Command active) = 0
1c	Check	X48	(Command error) = 0
2	Read request	D16	Gross weight
3	Read request	D17	Net weight
4	Read request	D18	Tare weight
5	Read request	D19	Sequence number for alibi memory
6	Read request	D21	Date (in BCD display)
7	Read request	D22	Time (in BCD display)

9.2.7.3 Exporting alibi data records

Example:

Operating sequence; see also Chapter [13.4](#)

1	Write request	D19	Sequence number for alibi memory
2	Write request	X122	Export selected data record from alibi memory.
2a	Wait	X122	= 0
1b	Wait	X49	(Command active) = 0
1c	Check	X48	(Command error) = 0
2	Read request	D16	Gross weight
3	Read request	D17	Net weight
4	Read request	D18	Tare weight
6	Read request	D21	Date (in BCD display)
7	Read request	D22	Time (in BCD display)

9.2.8 Configuration data

The configuration and calibration data of the EAROMs can be saved for back-up on the Notebook and downloaded, if necessary.

- ▶ Click the [Backup of Earom] menu item in the WEB menu.
 - ▷ The backup/restore menu is shown on the display.

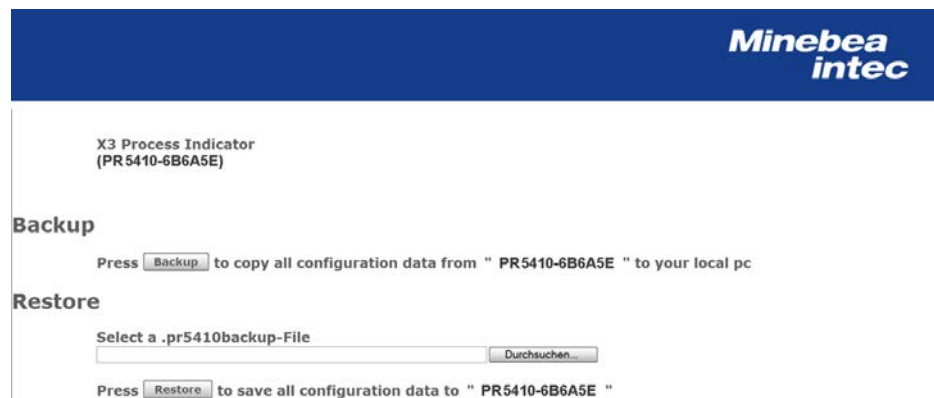

9.2.8.1 Saving configuration and calibration data

1. Click on [Backup] to create a backup .g. on the notebook.
2. Click on [Save as].
3. Create and open the required directory e.g. on the notebook.
4. Click on [Save] to save the backup file in the relevant directory.

9.2.8.2 Loading configuration and calibration data into the device

NOTICE

All data which can be configured in the Setup menu are overwritten!





► If the file is loaded into several devices, changing the network settings and the host name is indispensable!

1. Open the CAL switch; see Chapter 7.1.3.1.
2. Click on [Select File] (depending on the Internet browser).
3. e.g. on the notebook, navigate to the folder where the backup file was saved.
4. Select Backup file.
5. Click on [Restore].
 - ▷ The selected file is loaded into the device.
6. Click on the  symbol in the Internet browser to return to the WEB menu.
7. Close the CAL switch.

9.3 Resetting the device to the factory settings using the front-panel keys

Note:

Reset to the factory settings is possible only, when the CAL switch is open. The IP address and the Hostname remain unaffected.



1. Press .
 - ▷ **SEtUP** appears on the display.
2. Press .
 - ▷ **bIoS** appears on the display.
3. Press OK.
 - ▷ **bIoS...** appears on the display.
 - ▷ **FLASH** follows on the display.
4. Press  2x.
 - ▷ **dEL.EAr.** appears on the display.
5. Press OK.
 - ▷ **ErAS.E?** and then **no** appear on the display.
6. Press .

- ▷ YES appears on the display.
7. Press OK.
 - ▷ done appears on the display once the process is complete.
 8. Press  to restart the device.

9.4 Resetting the device to the factory settings

Note:

Reset to the factory settings is possible only, when the CAL switch is open. The IP address and the Hostname remain unaffected.

1. Click on .
2. Click on .
 - ▷ The following prompt window appears:

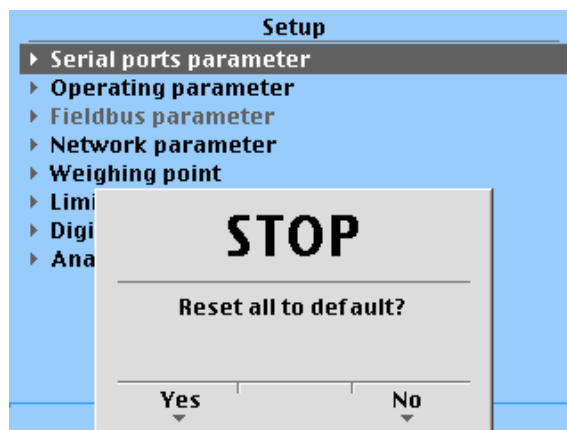

3. Press the [Yes] softkey to reset to the factory settings.
Press [No] if you want to keep the entered values unchanged.
 - ▷ The following messages show the respective progress:

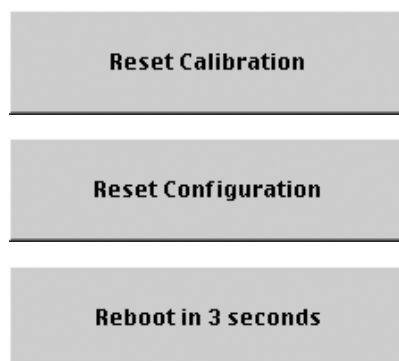

9.5 Updating new software with FlashIt

Note:

Always flash/load the BIOS into the device first, and then the firmware&application.

NOTICE

Once the device has been updated from version <4.00 to >4.00, it must be reset to the factory settings.

Before updating, save the configuration printout as a TXT file if necessary. This allows for the parameters to be re-entered manually in the device.

- ▶ A backup of version <4.00 cannot be loaded onto a device with version >4.00.
 - ▶ See Chapters [9.2.3](#) and [9.4](#).
-

9.5.1 Updating in network with a DHCP service

Requirements:

- Device and Notebook/PC are connected to the network.
- The automatic address assignment "DHCP" is activated in the device and in the notebook/PC, see Chapter [7.18.6](#).
- The "FlashIt!32" program (in a directory on the enclosed CD-ROM) is installed on the notebook/PC.
- The "FlashIt!32" program is started.

9.5.1.1 Operations at the device

⚠ WARNING

Working on the device while it is switched on may have life-threatening consequences.

- ▶ Product operation must be performed by trained and qualified personnel who are aware of and able to deal with the related hazards and take suitable measures for self-protection.
-

1. Press .

▷  appears on the display.

2. Press .

▷  appears on the display.

3. Press OK.

▷  appears on the display.

FLASH follows on the display.

4. Press OK.

▷ EtHER appears on the display.

5. Press OK.

▷ dHCP... appears on the display.

The device waits for address assignment by the server.

172.024. The more significant part of the IP address is displayed for approx. 2 seconds.

6. Make sure to note down the digit sequence, because it must be entered into the "Flash!t32" window subsequently.

▷ 021.081. The less significant part of the IP address is displayed for approx. 2 seconds.

7. Make sure to note down the digit sequence, because it must be entered into the "Flash!t32" window subsequently.

▷ FLASH? appears on the display.

Now the device is ready to load the software.

9.5.1.2 Loading the software on your notebook/PC

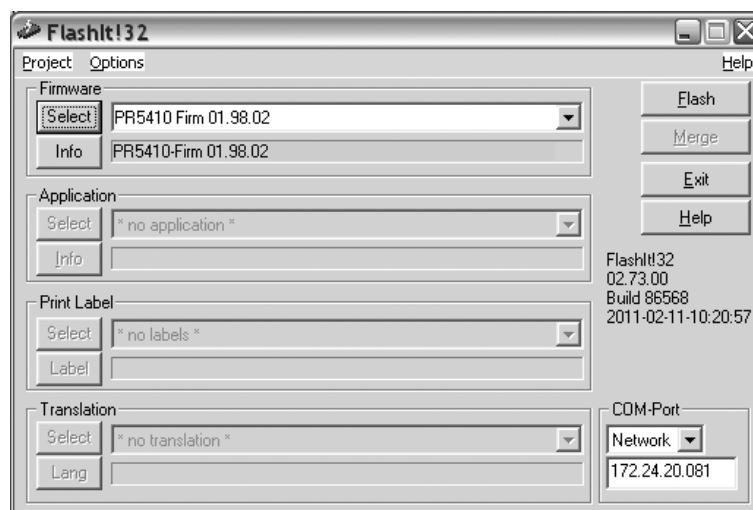

1. Click the relevant file in the "Explorer" with the mouse and drag it into the [Select] window, (or use 'Copy and paste').
2. Under [COM-Port] select "Network" and enter the devices IP addresses.
3. Click [Flash] to start the procedure.
 - ▷ As soon as software loading is completed the device will be re-started.
4. Load next file, as described.

9.5.2 Updating via a point-to-point connection with DHCP service

Requirements:

- Device and notebook/PC are connected to each other.
- The automatic address assignment "DHCP" is activated in the device and in the notebook/PC; see Chapter 7.18.6.
- The "FlashIt!32" program (in a directory on the enclosed CD-ROM) is installed on the notebook/PC.
- The "FlashIt!32" program is started.

9.5.2.1 Operations at the device

WARNING

Working on the device while it is switched on may have life-threatening consequences.

- ▶ Product operation must be performed by trained and qualified personnel who are aware of and able to deal with the related hazards and take suitable measures for self-protection.

1. Press .

▷  appears on the display.

2. Press .

▷  appears on the display.

3. Press OK.

▷  appears on the display.

 follows on the display.

4. Press OK.

▷  appears on the display.

5. Press OK.

▷  appears on the display.

The device waits for address assignment by the server.

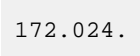
 The more significant part of the IP address is displayed for approx.

2 seconds.

6. Make sure to note down the digit sequence, because it must be entered into the "FlashIt!32" window subsequently.

▷ 021.081. The less significant part of the IP address is displayed for approx. 2 seconds.

7. Make sure to note down the digit sequence, because it must be entered into the "FlashIt!32" window subsequently.

▷ FLASH? appears on the display.

Now the device is ready to load the software.

9.5.2.2 Loading the software on your notebook/PC

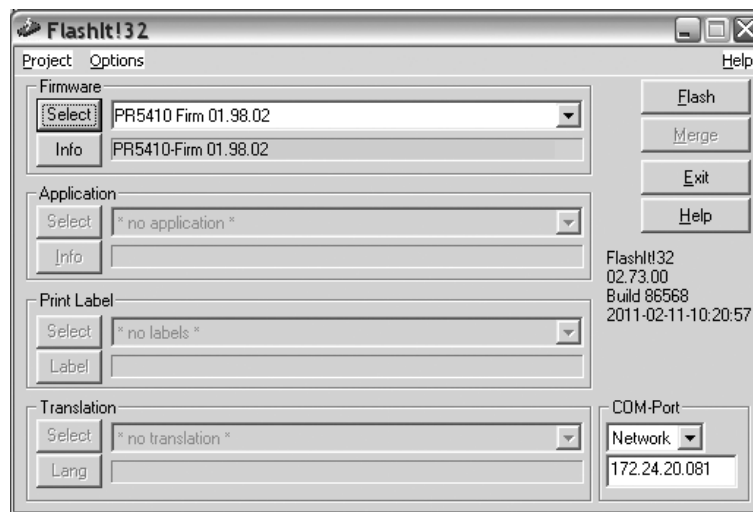

1. Click the relevant file in the "Explorer" with the mouse and drag it into the [Select] window, (or use 'Copy and paste').
2. Under [COM-Port] select "Network" and enter the devices IP addresses.
3. Click [Flash] to start the procedure.
 - ▷ As soon as software loading is completed the device will be re-started.
4. Load next file, as described.

9.5.3 Updating with a fixed IP address

Requirements:

- Device and notebook/PC are connected to a network/each other.
- The automatic address assignment "DHCP" is deactivated in the device and in the notebook/PC, see Chapter [7.18.6](#).
- Notebook/PC is set to a fixed IP address.

Note:

On a point-to-point connection the device and notebook/PC must be set to a fixed IP address which has the same address range given by the subnet mask.

Example:

PR 5410: IP address 192.24.22.1

Notebook/PC: IP address 192.24.22.2

Device and notebook/PC have the subnet mask 255.255.255.0.

- The "FlashIt!32" program (in a directory on the enclosed CD-ROM) is installed on the notebook/PC.
- The "FlashIt!32" program is started.

9.5.3.1 Device presettings in the Setup menu

1. Click on  - [Network parameter].

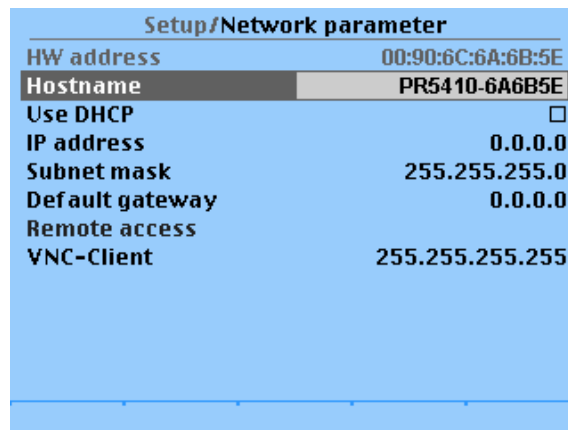

2. Deactivate [Use DHCP].
3. Enter the corresponding IP address.

Note:

On a point-to-point connection the device and notebook/PC must be set to a fixed IP address which has the same address range given by the subnet mask.

Example:

PR 5410: IP address 192.24.22.1

Notebook/PC: IP address 192.24.22.2

Device and notebook/PC have the subnet mask 255.255.255.0.

4. Enter the corresponding subnet mask.
5. Press  to exit the window and to save the changes.

9.5.3.2 Operations at the device

WARNING

Working on the device while it is switched on may have life-threatening consequences.

- ▶ Product operation must be performed by trained and qualified personnel who are aware of and able to deal with the related hazards and take suitable measures for self-protection.

1. Press .

▷ `SEtUP` appears on the display.

2. Press .

▷ `bIoS` appears on the display.

3. Press OK.

▷ `bIoS...` appears on the display.

`FLASH` follows on the display.

4. Press OK.

▷ `EtHER` appears on the display.

5. Press OK.

▷ `dHCP...` appears on the display.

The device waits for address assignment by the server.

`172.024.` The more significant part of the IP address is displayed for approx. 2 seconds.

6. Make sure to note down the digit sequence, because it must be entered into the "FlashIt!32" window subsequently.

▷ `021.081.` The less significant part of the IP address is displayed for approx. 2 seconds.

7. Make sure to note down the digit sequence, because it must be entered into the "FlashIt!32" window subsequently.

▷ `FLASH?` appears on the display.

Now the device is ready to load the software.

9.5.3.3 Loading the software on your notebook/PC

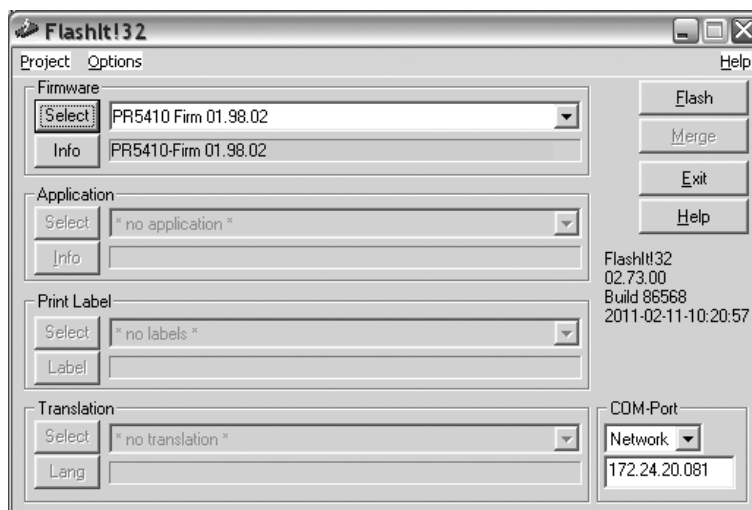

1. Click the relevant file in the "Explorer" with the mouse and drag it into the [Select] window, (or use 'Copy and paste').
2. Under [COM-Port] select "Network" and enter the devices IP addresses.
3. Click [Flash] to start the procedure.
 - ▷ As soon as software loading is completed the device will be re-started.
4. Load next file, as described.

10 ModBus protocol

10.1 General description

The ModBus protocol implemented in the device enables rapid, simple, and reliable communication between a PC or SPS and up to a maximum of 127 devices.

The ModBus protocol allows access to all data published in the SPM table of the relevant application.

Implementation:

The functions 1, 2, 3, 4, 5, 6, 8, 15, and 16 are supported.

Bits can only be read or set individually or in groups of eight.

10.2 SPM data in PR 1612 ModBus mode

For access via ModBus, the PR 1612 ModBus mode is switched on via  - [Serial ports]- [ModBus-RTU]- [Param]- [ModBus mode]- [PR 1612 ModBus].

Read data

Byte address	Weight in 32-bit integer format
60...63	Gross weight
64...67	Net weight (gross if not tared)
68...71	Tare weight (0 if not tared)

Read data

Address	Read "Word" (display in binary format)
W201	0E00000T 00000000 E: ADC error T: Instrument is tared.
W203	000S00MZ 00000000 S: Device is in setup mode. M: Weight is stable (standstill). Z: Weight within ¼ d of 0
W204	0000D000 00000000 D: Gross weight <0 or >Max (dimmed)
W205	TA000000 00000000 T: Instrument is tared. A: Analog test is active.
W231	00021MRZ 00000000 2: Limit 2 1: Limit 1 M: Weight is stable (standstill). R: Weight within zero-setting range Z: Weight within ¼ d of 0

Write data

Bit address	Value in 32-bit integer format
W100	Zero device: Write value 256
W101	Tare device: Write value 256 Reset the tare of the device: Write value 512

11 SMA protocol

11.1 General information

The protocol of the "Scale Manufacturers Association" (SMA) provides a simple access to the scale. It can be used for reading data, or for executing functions.

The RS-232 or RS-485 interface is used as an interface.

Fixed interface settings are 8 bits, no parity and 1 stop bit.

The commands to the transmitter are printable ASCII characters starting with <LF> = 0A hex and ending with <CR> = 0D hex.

The transmitter sends a reply on each received command after approx. 100 μ s. With commands that wait for standstill of the weight value, the reply can be delayed by the timeout.

The following commands are supported:

W, Z, D, A, B, <ESC>, H, P, Q, R, S, T, M, C, I, N

12 Fieldbus interface

12.1 General notes

The PR 5410 can be turned into a field bus slave by inserting a field bus interface card . This enables one or more devices to be included under a communication master (e.g., Siemens S7 ProfiBus).

The update rate is 50 ms.

The interface is configured under -[Fieldbus parameter] in the device. The corresponding field bus protocol (in this case: ProfiBus-DP) is shown.

Setup/Fieldbus parameter	
Fieldbus protocol	Profibus-DP
Profibus-DP address	1

The field bus exchanges its data cyclically with each slave. That means: In each cycle, the entire data range is written and read, even if there are no changes to the data content.

Concept definition

Term/Abbreviation	Description
Master	Field bus master, usually an SPS
Slave	Field bus device
MOSI	Master Out Slave In = data is written from the SPS via the field bus to the device.
MISO	Master In Slave Out = data is returned from the device via the field bus to the SPS.

12.2 Scale protocol (8-byte) for the "Standard" application

The interface works with an 8-byte write window and an 8-byte read window for each weighing point.

Note:

All fieldbus data is only valid, if 'Read_Value_Selected' has been reflected.

12.2.1 Data exchange range

Overview

Byte	0, 1, 2, 3	4	5	6, 7
MOSI	Write data	Read_Value_Select	Write_Value_Select	Control bits (control bits)
MISO	Read data	Read_Value_Selected	Status bits (status bits)	Status bits (status bits)

Write window (MOSI)

Byte	Field	Description
0	Write data (MSB)	Contains the data to be written, e.g., analog output.
1	Write data	
2	Write data	
3	Write data (LSB)	
4	Read_Value_Select	Selects the function for reading data.
5	Write_Value_Select	Selects the function for writing data.
6	free	In direct access, control bits are independent of the write or read request. "Free" bits are application specific.
7	free	
	free	
	Res Power	
	Res Test	
	Set Test	
	Res Tare	
	Set Tare	
	Set Zero	
	Bit 7	Bit 0

Field	Size	Function
Write data	4 bytes	Data to be written as a binary 32-bit value with plus or minus sign. Data type: DINT
Read_Value_Select	1 byte	Function for selecting the read request
Write_Value_Select	1 byte	Function for selecting the write request
ResPower	1 bit	PowerFail is reset.
ResTest	1 bit	The test operating mode is finished.
SetTest	1 bit	The test operating mode is started. Now the test value can be read out by reading the gross weight.
ResTare	1 bit	Tare is reset.
SetTare	1 bit	The weighing point is tared.
SetZero	1 bit	The weighing point is set to zero.

Read window (MISO)

Byte	Field	Description						
0	Read data (MSB)	Contains the data to be read, e.g. gross value.						
1	Read data							
2	Read data							
3	Read data (LSB)							
4	Read_Value_Selected	Read_Value_Select (function) from the write window is mirrored if the data in "Read data" is available.						
5	Write Active	In direct access, status bits are independent of the write or read request. "Free" bits are application specific.						
	Power Fail							
	free free free free free							
6	Cmd Busy	Tare Active Cal Changed Test Active						
	Cmd Error free free free							
7	OutOf Range	Above Max ADU Error						
	Standstill Inside ZSR Center Zero Below Zero Overload							
	Bit 7	Bit 6	Bit 5	Bit 4	Bit 3	Bit 2	Bit 1	Bit 0

Field	Size	Function
Read data	4 bytes	Data to be read as a binary 32-bit value with plus or minus sign. Data type: DINT
Read_Value_Selected	1 byte	Acknowledgment of the transmitted function number.
WriteActive	1 bit	The function selected with Write_Value_Select has been executed once. This bit is deleted if Write_Value_Select is set to 0.
PowerFail	1 bit	Is set when switching on the device. Is reset by ResPower with transition from 0→1.
CmdBusy	1 bit	The device is busy executing a function (e.g., waiting for a standstill for taring)
CmdError	1 bit	The device has interrupted the execution of a command (e.g., standstill could not be reached within the defined standstill time). The error number can be read from "LASTERROR", see Chapter 12.2.5.5 .
Tare_Active	1 bit	The scale has been tared.
Cal_Changed	1 bit	The device has been calibrated. When this bit is 1, the weighing point parameters (EX-PO/UNIT/STEP+FSD) must be read again. Set after "Power on" and reset after reading the FSD.

Field	Size	Function
Test_Active	1 bit	The device executes the ADC test. The read weight value is not the gross value, but the test value.
OutOfRange	1 bit	Below zero or above max. (FSD).
Standstill	1 bit	The scale is stable.
InsideZSR	1 bit	The gross weight value is within the zero setting range.
CenterZero	1 bit	The weight value is within center zero (0 ± 0.25 d).
BelowZero	1 bit	The weight value is negative (gross < 0 d).
Overload	1 bit	The weight value has exceeded the measuring range. No valid weight data is specified (gross > FSD+overload).
AboveMax	1 bit	The weight value has exceeded the max. (FSD), but is still within max. + permissible overload (gross \leq FSD+overload).
ADUError	1 bit	AD conversion error, see Chapter 12.2.5.2 .

12.2.2 Reading and writing data with function numbers

12.2.2.1 Reading data

Procedure:

1. Write the function number as **Read_Value_Select** in byte 4 of the write window (e.g., 9 = net weight).
2. Wait until **Read_Value_Selected** in byte 4 of the read window is equal to **Read_Value_Select** of the write window.
 - ▷ The requested value is available in bytes 0-3.

Action of the master	Slave reaction
Write function number to Read_Value_Select .	
	Write requested data in Read_Data (bytes 0-3).
	Copy Read_Value_Select to Read_Value_Selected .
Wait until Read_Value_Selected = Read_Value_Select .	
Read requested data in Read_Data (bytes 0-3).	

12.2.2.2 Writing data

Procedure:

1. Wait until **Write_Active** = 0 in the read window (slave is ready to receive new data).
2. Write value in bytes 0-3 of the write window.

3. Write the function number as **Write_Value_Select** in byte 5 of the write window (e.g., "Basic" application: 190 = analog output 1).
4. Wait until **Write_Active** = 1 in the read window.
5. Write 0 in byte 5 (**Write_Value_Select**).
 - ▷ **Write_Active** is reset.

Action of the master	Slave reaction
Write value in Write_Data (bytes 0-3).	
Write function number to Write_Value_Select .	
	Read data from Write_Data (bytes 0-3).
	Set the Write_Active bit.
Wait until Write_Active has been set.	
Write 0 in Write_Value_Select .	
	Reset the Write_Active bit.

12.2.2.3 Writing bits

In addition to the control bits in bytes 6/7, further bits can be set and, if necessary, reset directly with **Write_Value_Select**.

To set bits 80 to 127, the corresponding function number is written to **Write_Value_Select** (see Chapter [12.2.5](#)).

To reset bits 80 to 89, the corresponding function number +128 (208 to 217) is written to **Write_Value_Select**.

Action of the master	Slave reaction
Writing the bit address as a function number to Write_Value_Select .	
	The bit from Write_Value_Select is set and the corresponding function carried out.
	Set the Write_Active bit.
Wait until Write_Active has been set.	
Write 0 in Write_Value_Select .	
	Reset the Write_Active bit.

12.2.2.4 Reading bits

Reading individual bits which are not contained directly in the read window is only possible with a corresponding function number and the data in **Read_Data** (Byte 0-3) of the read window. In those bytes, the bits must be evaluated individually.

The procedure is the same as that described in Chapter [12.2.2.1](#).

12.2.3 Reading and writing bits directly

For reading status bits and for writing direct control bits, no procedure is required. The general status bits are always provided and need not be requested. The direct control bits are also available continuously.

12.2.3.1 Reading status bit

The status bits in bytes 5-7 of the read window are always available and can be read directly by the master.

12.2.3.2 Writing control bits

Some device functions can be executed by setting bits directly in bytes 6 and 7 (control bytes) of the write window.

Action of the master	Slave reaction
Set bits in the control byte .	Function is executed.
Reset bits in the control byte .	

12.2.4 Waiting for the result of the action

When an action requiring more time is started, the end of execution can also be waited for.

Action of the master	Slave reaction
For setting bits, see Chapter 12.2.2.3 or 12.2.3.2 .	Set the CmdBusy bit.
	Function is executed.
	In the event of an error: Set the CmdError bit and the LastError byte.
	If the function is executed or timeout: reset the CmdBusy bit.
Wait until CmdBusy = 0.	
Check the CmdError bit.	
If CmdError is set: Evaluate the LastError (for function number 4, see Chapter 12.2.5.5)	
Set the ResetError bit (for function number 121, see Chapter 12.2.5.13).	
	The ResetError bit is reset.
	The CmdError bit is reset.

12.2.5 Function numbers

Function numbers are written to MOSI by the master (SPS) and reflected in MISO by the PR 5410.

- Funktionsnummer 0: I/O status bits (read), see Chapter [12.2.5.1](#)
- Function number 1: scale status (read), see Chapter [12.2.5.2](#)
- Function number 4: calibration information, error byte (read), see Chapter [12.2.5.5](#)
- Function number 5: device type and software version (read), see Chapter [12.2.5.6](#)
- Function number 6: serial number of the weighing point (read), see Chapter [12.2.5.7](#)
- Function numbers 8 to 15: weight data (read), see Chapter [12.2.5.9](#)
- Function numbers 24 to 29: Limit value (read/write), see Chapter [12.2.5.10](#)
- Function numbers 30, 31: values of the current weighing point (read), see Chapter [12.2.5.11](#)
- Function numbers 80 to 89: state-controlled action bits (write), see Chapter [12.2.5.12](#)
- Function numbers 112 to 119; 121: transition-controlled action bits (write), see Chapter [12.2.5.13](#)

12.2.5.1 Function number 0: I/O status bits (read)

Dynamic status

	Bit 7	Bit 6	Bit 5	Bit 4	Bit 3	Bit 2	Bit 1	Bit 0
Byte 0						Input 3	Input 2	Input 1
Byte 1						Output 3	Output 2	Output 1
Byte 2						Limit 3	Limit 2	Limit 1
Byte 3								

12.2.5.2 Function number 1: scale status (read)

Dynamic status

	Bit 7	Bit 6	Bit 5	Bit 4	Bit 3	Bit 2	Bit 1	Bit 0
Byte 0	OutOf Range	Standstill	Inside ZSR	Center Zero	Below Zero	Overload	Above Max	ADU Error
Byte 1				E9	E6	E1	E3	E7
Byte 2						PowerFail	Action Active	CmdError
Byte 3						Tare Active	Cal Changed	Test Active

Note:

Byte 0 corresponds to byte 7 in the output area. Weight error in byte 1, see table in Chapter [16.1](#).

Field	Function
ADUError	AD conversion error (OR function of bits E1, E3, E7).
AboveMax	The weight value has exceeded the Max (FSD), but is still within Max + permissible overload (gross \leq FSD+overload).
Overload	The weight value has exceeded the measuring range. No valid weight data is specified (gross $>$ FSD+overload); error 2 .
BelowZero	The weight value is negative (gross $<$ 0d).
CenterZero	The weight value is within center zero (0 ± 0.25 d)
InsideZSR	The gross weight value is within the zero setting range.
Standstill	The scale is stable.
OutOfRange	Below zero or above max. (FSD).
E7	The measuring signal is negative (inverse conversion); error 7
E6	Sense voltage not present or too low; error 6
E3	The measuring signal is >36 mV (no end of conversion); error 3
E1	Arithmetic error (overflow); error 1
E9	No communication with xBPI scale; error 9
CmdError	Error during execution (CmdError); e.g., the "taring" operation is not processed, because the scale is not at a standstill. The error is stored in LastError (function number 4). The bit is reset with the ResetError bit (function number 121, see Chapter 12.2.5.13).
ActionActive	The device is busy executing a function (e.g., waiting for downtime for taring).
PowerFail	Power failure; is always set after power on. The PowerFail bit is reset with the ResetPWF bit (function number 85, see Chapter 12.2.5.12) "Reset power failure".
Test_Active	The device executes the ADC test. The read weight value is not the gross value, but the test value.
Cal_Changed	The device has been calibrated. When this bit is 1, the weighing parameters (EXPO/UNIT/STEP) must be read again. Set after "Power on" and reset after reading the FSD (Full scale deflection).
Tare_Active	The scale has been tared.

12.2.5.3 Function number 2: For internal use only.**12.2.5.4 Function number 3: For internal use only.****12.2.5.5 Function number 4: calibration information, error byte (read)**

Byte	Description
0: EXPO	One byte for the position of the decimal point; content in decimal form: 0 to 255.
	0 = 000000
	1 = 00000.0
	2 = 0000.00
	3 = 000.000
	4 = 00.0000
5 = 0.00000	
1: UNIT	One byte for the weight unit; content in decimal form: 0 to 255
	2 = g (grams)
	3 = kg (kilograms)
	4 = t (tons)
	5 = lb (pounds)
2: STEP	One byte for the scale interval; content in decimal form: 0 to 255
	1 = scale interval "1"
	2 = scale interval "2"
	5 = scale interval "5"
	10 = scale interval "10"
	20 = scale interval "20"
50 = scale interval "50"	
3: LASTERROR	Last error byte; see also CmdError bit, number of LASTERROR:
	8 = no standstill was achieved (e.g., when taring).
	13 = zero setting is not possible. The scale has been tared.
	18 = negative weight value when taring and W&M mode on.
	147 = no zero setting; weight not within zero setting range.
255 = general command error	
Note:	
Other error nos are possible.	

12.2.5.6 Function number 5: device type and software version (read)

	Bit 7	Bit 6	Bit 5	Bit 4	Bit 3	Bit 2	Bit 1	Bit 0
Byte 0	TYPE MSB							
Byte 1	TYPE LSB							
Byte 2	MAINVERSION							
Byte 3	SUBVERSION							

12.2.5.7 Function number 6: serial number of the weighing point (read)

	Bit 7	Bit 6	Bit 5	Bit 4	Bit 3	Bit 2	Bit 1	Bit 0
Byte 0	Serial number MSB							
Byte 1	Serial number							
Byte 2	Serial number							
Byte 3	Serial number LSB							

e.g.: 148388723 = 08D83B73_{hex}

12.2.5.8 Function number 7: For internal use only.**12.2.5.9 Function number 8 to 22: weight data (read)**

The gross, net, and tare weight are stored as a DINT fix point. The real data value is derived from DINT and EXPO as follows:

$$\text{Value}_{\text{Real}} = \text{reading}_{\text{DINT}} \times 10^{(-\text{EXPO})}$$

Function number 8	Current gross value
Function number 9	Current net value, if tared; otherwise gross
Function number 10	Current tare value, if tared; otherwise 0
Function number 11	Current gross/net weight selected with bit 72.
Function number 12	Current gross value in internal resolution (1/100d)
Function number 13	Current tare value in internal resolution (1/100d)
Function number 14	Max (Full scale deflection)
Function number 15	Reserved for internal use.
Function number 16	Print gross weight/enter in Alibi memory.
Function number 17	Print net weight/enter in Alibi memory.
Function number 18	Print tare weight/enter in Alibi memory.
Function number 19	Print sequence number/enter in Alibi memory.
Function number 20	Output value (BCD format)
Function number 21	Print date/enter in Alibi memory (BCD format).
Function number 22	Print time/enter in Alibi memory (BCD format).

12.2.5.10 Function number 24–29: Limit value (Read/Write)

Function number 24	Limit 1 on
Function number 25	Limit 1 off
Function number 26	Limit 2 off
Function number 27	Limit 2 off
Function number 28	Limit 3 on
Function number 29	Limit 3 off

12.2.5.11 Function number 30, 31: Fixed values (Read/Write)

Function number 30	Fixed value for analog output, value (num) 0...20000 corresponds to 20 mA
Function number 31	Fixed value for preset tare, see also SetFixTare , GetFixTare in Chapter 12.2.1 .

12.2.5.12 Function number 80–92: state-controlled action bits (write)**Note:**

For setting bits, see Chapter [12.2.2.3](#).

Only setting and resetting of single bits is possible.

When changing a bit from 0 to 1, the corresponding action starts. After handling the command, the bit must be reset. Application: The master writes cyclically.

The bit is set as **Write_Value_Select** with the specified number (see Chapter [12.2.2.3](#)).

The bit is reset at the specified number +128.

Function number 80	SetZero	Set the gross weight to zero.
Function number 81	SetTare	The weighing point is tared.
Function number 82	ResetTare	Reset tare.
Function number 83	SetTest	Start the ADC test.
Function number 84	ResetTest	Finish the ADC test.
Function number 85	ResetPwf	Reset the PowerFail bit (function number 1; the bit was set after "power on").
Function number 86	SetFixTare	Taring with weight in numerical address D31 "FixTare".
Function number 87	GetFixTare	The current gross weight is copied to the numerical address D31.
Function number 89	ResetError	The CmdError error bit is reset.
Function number 90	GetAlibi	Read out selected record of the alibi memory.
Function number 91	GetDate	Read out current time and date.

Function number 92	SetDate	Save (set) current time and date.
--------------------	---------	-----------------------------------

12.2.5.13 Function number 112–119, 124: transition-controlled action bits (write)

For setting bits, see Chapter [12.2.2.3](#).

As soon as the bit has been set, it is reset internally and the process is carried out; this process is transition-controlled (for one write operation).

The bit is set as **Write_Value_Select** with the specified number (see Chapter [12.2.2.3](#)).

Function number 112	SetZero
Function number 113	SetTare
Function number 114	ResetTare
Function number 115	SetTest
Function number 116	ResetTest
Function number 117	ResetPwf
Function number 118	SetFixTare (function number 86, see Chapter 12.2.5.12).
Function number 119	GetFixTare (function number 87, see Chapter 12.2.5.12).
Function number 121	ResetError
Function number 122	GetAlibi
Function number 123	GetDate
Function number 124	SetDate

Note:

To prevent frequent writing to the EAROM, the write interval should be no shorter than 15 seconds.

12.2.6 Example: reading the gross weight

Input range (MOSI)

Byte	Value	Description
0		
1		
2		
3		
4	08	Read the gross weight (for function number 8, see Chapter 12.2.5.9)
5		
6		
7		

Output range (MISO)

Byte	Value								Description
0	00								Gross weight - byte 0 (MSB)
1	00								Gross weight - byte 1
2	04								Gross weight - byte 2
3	D2								Gross weight - byte 3 (LSB)
4	08								Gross weight request detected.
5	Write Active	Power Fail							In direct access, status bits are independent of the write or read request.
6	Cmd Busy	Cmd Error				Tare Active	Cal Active	Test Active	
7	OutOf range	Stand- still	Inside ZSR	Center Zero	Below Zero	Over- load	Above Max	ADU Error	
	Bit 7	Bit 6	Bit 5	Bit 4	Bit 3	Bit 2	Bit 1	Bit 0	

The gross value (hex:000004D2 <=> 1234) can be read from bytes 0...3.
Negative values are output in the second complement.

12.2.7 Special note for DeviceNet and EtherNet IP

With these fieldbus types, the sequence of the bytes (only applicable for words and individual bytes) is inverted.

With long words, this problem does not arise due to compensation by the firmware.

Sequence of data bytes 0...3:

Standard sequence		Sequence for DeviceNet and EtherNet-IP	
Byte 0	Read data 0 (MSB)	Byte 0	Read data 3 (LSB)
Byte 1	Read data 1	Byte 1	Read data 2
Byte 2	Read data 2	Byte 2	Read data 1
Byte 3	Read data 3 (LSB)	Byte3	Read data 0 (MSB)

Consequently, the sequence on the PLC side must be changed when using the "DeviceNet" and "EtherNet IP" fieldbus types.

12.3 Filling protocol (64-Byte) for the "EasyFill" application

The "EasyFill" application uses a 64-byte interface.

The 8-byte scale protocol for the "Standard" application is not available.

12.3.1 Write window (input area)

Data are transferred from the master (PLC) to the slave (PR 5410) in this window.

12.3.2 Read window (output area)

Data are transferred from the slave (PR 5410) to the master in this window.

The data required for monitoring and controlling filling does not fit in a 64-byte write window. For this reason the system differentiates between system and material

parameters. The value of the first byte can be used to determine whether the data refers to the system or the material.

12.3.3 Indicator functions

E.g., gross, net, tare; all indicator statuses and commands are available at the same time. In contrast to the 8-byte interface, in the 64-byte interface the parameters, statuses, and values are all available simultaneously.

Some values may be output as data type DINT or REAL depending on write bit 2 in byte 2.

12.3.4 Filling functions

12.3.4.1 Filling start

12.3.4.1.1 General information

There are two ways to carry out filling:

- (A) Filling parameters are written at each start by the PLC.
- (B) Filling parameters are stored in the device (PR 5410).

Requirements:

The system is ready.

The device has been checked to ensure it is ready for the start of filling. It is ready when no filling is currently taking place and no parameters are being changed.

This status is signaled by bit 2 (Ready) in byte 3.

12.3.4.1.2 Filling start A

The material parameters can be found in the PLC.

1. Write the material parameters.
 - Set point
 - Preset
 - Material overshoot (OVS)
 - Tolerance above/below set point
 - Calming time

2. Set start bit:

Byte 1

These parameters are applied with the rising edge of the start bit. If the parameters are valid, the filling process is started and the Dosing_Run bit is set.

The end of the filling process is signaled by the falling edge of the Dosing_Run bit.

12.3.4.1.3 Filling start B

The material parameters can be found in the device material table (PR 5410).

1. Write the material ID to byte 3.
2. Set start bit:
0000 1000 in byte 1

12.3.4.2 Filling control

12.3.4.2.1 Pausing filling

Requirements:

The system is filling, i.e.,

- the Dosing_Run bit is active
- and
- the hold bit is not active

Example:

Set stop bit with 0100 0000 in byte 1.

Filling stops with the rising edge and the system goes to the hold status (hold state).

If the system is in hold state, filling can be restarted or canceled.

12.3.4.2.2 Restarting filling

Requirements:

The system stops, i.e., the Hold_state bit is active.

Example:

Set stop bit with 0010 0000 in byte 1.

Filling starts again with the rising edge and the system leaves the hold status (hold state) and continues filling.

12.3.4.2.3 Canceling filling

Requirements:

The system stops, i.e., the Hold_state bit is active.

Example:

Set cancel bit with 0001 0000 in byte 1.

Filling starts again with the rising edge and the system leaves the hold status (hold state) and goes back to the ready status (ready/idle).

12.3.4.3 Filling report

The filling results are stored after filling and only overwritten when there is a new result.

12.3.4.4 Filling error

Last_Error

The last error number is retained until it is reset.

The possible error numbers are listed in Chapter [16.6.2](#).

12.3.4.5 Reading the material table

The material parameters can be read from the material table of the device (PR 5410).

Procedure:

1. Write the material ID to byte 3.
2. Write command 1 to byte 0 in order to see the material parameters on the read side.
3. Write command 0000 0001 to byte 2 in order to copy the material parameters from the material table.

- ▷ If all parameters of the material were available to be read, 1000 0000 is set to byte 2.
- 4. Write command 0 to byte 0 in order to see the filling parameters again on the read side.

12.3.5 Setup of the fieldbus interface

For description of the data types see Chapter [13.2](#).

12.3.5.1 PLC → write window EasyFill

Bytes 0...63	Name	Type of data	Function
Byte 0	TableSelect	USINT	The first byte controls (multiplexes) the data written in the read window by the device. A "0" describes the read window according to the system data layout. A "1" copies the material data to the read window.
Byte 1 Bit 0: MSB	Bit 0: start filling Bit 1: stop filling Bit 2: restart filling Bit 3: cancel filling Bit 4: load material and start filling Bit 5: print last filling result Bit 6: reserved Bit 7: reserved	BOOL	<p>Bit 0: EasyFill adopts the sent material parameters from byte 4 with the rising edge of this bit. A valid set point (byte 4...7) that can be coded as DINT or REAL is required. The filling process can be started when the ready bit is set.</p> <p>Bit 1: rising edge during filling</p> <p>Bit 2: rising edge in the stop status (hold state)</p> <p>Bit 3: rising edge in the stop status (hold state)</p> <p>Bit 4: rising edge: A valid material ID is required in byte 3.</p> <p>Bit 5: rising edge: The printout of the last filling result starts.</p>

Bytes 0...63	Name	Type of data	Function
Byte 2	Bit 0: reset power failure (power fail) Bit 1: reset error Bit 2: weights as DINT Bit 3: zero Bit 4: tare Bit 5: reset tare Bit 6: filling mode Bit 7: read material from the material table	BOOL	Bit 0: rising edge Bit 1: rising edge: resets the error flag and error code. Bit 2: status-controlled: Value: 0 = Real, 1 = DINT Bit 3: rising edge Bit 4: rising edge Bit 5: rising edge Bit 6: status-controlled: 0 = fill, 1 = empty Bit 7: rising edge: A valid material ID is required in byte 3. Filling does not start. This function can be used to display material parameters on external displays.
Byte 3	Material ID	BYTE	Value range: 1...10
Byte 4...7	Set point	DINT/REAL	Weight
Byte 8...11	Preset	DINT/REAL	Preset point for switching from coarse flow to fine flow.
Byte 12...15	Material overshoot (OVS)	DINT/REAL	Weight
Byte 16...19	Calming time	DINT	[ms]
Byte 20...23	Tolerance above set point	DINT/REAL	Weight
Byte 24...27	Tolerance below set point	DINT/REAL	Weight

12.3.5.2 Read window EasyFill → PLC

The data required for monitoring and controlling filling does not fit in a 64-byte write window. For this reason the system differentiates between system and material parameters. The value of the first byte can be used to determine whether the data refers to the system or the material.

12.3.5.2.1 System data

Before starting filling, a check must be carried out to ensure that the system is ready (byte 3: bit 2).

The Dosing_Run bit is set once filling has successfully started.

Bytes 0...63	Name	Type of data	Function
Byte 0	TableSelect	USINT	Content of read data: 0 = system data, 1 = material data

Bytes 0...63	Name	Type of data	Function
Byte 1 Bit 0: MSB	Bit 0: ADC error Bit 1: above max. + still permissible range (OVL) Bit 2: above max. (FSD) Bit 3: below zero Bit 4: zero $\pm 1/4$ d Bit 5: within zero set range (ZSR) Bit 6: weight is stable Bit 7: weight above max. (FSD) and below overload	BOOL	
Byte 2	Bit 0: read material data valid Bit 1: change calibration Bit 2: tare Bit 3: reserved Bit 4: reserved Bit 5: power failure (power fail) Bit 6: within menu [Set-up]/[Configuration] Bit 7: filling mode	BOOL	Bit 0: The material data is available. Bit 1: Calibrate weighing point. Bit 2: Set tare of the instrument. Bit 5: After a power failure the bit is set and can be reset by bit 0 in byte 2. Bit 6: Filling is not possible within the menu items. Bit 7: status-controlled: 0 = fill, 1 = empty
Byte 3	Bit 0: error in the application Bit 1: filling is active Bit 2: system ready Bit 3: filling stopped Bit 4: coarse flow Bit 5: fine flow Bit 6: calming time Bit 7: tolerance alarm	BOOL	Bit 0: Error bit is set if any action has failed. We recommend evaluating the error bit (Appl_Error) and the detailed error code in byte 63 after each action. Bit 1: The filling phase is active. Bit 2: The system is ready for filling. Bit 3: Filling was stopped. Bit 4: System is filling: coarse flow bit is set. Bit 5: System is filling: fine flow bit is set. Bit 6: The bit is set according to the set calming time. Bit 7: alarm if tolerance is above/below set point
Byte 4...7	Gross	DINT/REAL	Weight
Byte 8...11	Net	DINT/REAL	Weight
Byte 12...15	Tare	DINT/REAL	Weight

Bytes 0...63	Name	Type of data	Function
Byte 16...19	Max. weight (FSD)	DINT/REAL	Weight
Byte 20...23	Min. weight	DINT/REAL	Weight
Byte 24...27	Scale interval	DINT/REAL	Weight
Byte 28	Exponent	USINT	Number of decimal places Example: 1.23 is displayed Exponent: 2
Byte 29...30	Unit	STRING_2	Unit in plain text "t", "kg", "g", "lb"
Byte 31	Reserved		
Byte 32...35	Gross filling result	DINT/REAL	The filling results are stored after filling and only overwritten when there is a new result.
Byte 36...39	Tare filling result	DINT/REAL	
Byte 40...43	Net filling result	DINT/REAL	
Byte 44...47	Set point filling result	DINT/REAL	
Byte 48...51	Date of filling result	DINT	Example: 20161116h corresponds to November 16, 2016
Byte 52...55	Time of filling result	DINT	Example: 14153199h corresponds to 14:15:31 and 99 ms
Byte 56...59	Sequence number of filling result	DINT	Sequential number
Byte 60	Filling result status	BYTE	1 = successful, 2 = tolerance alarm, 3 = canceled
Byte 61...62	Reserved		
Byte 63	"Last_Error" error		The last error number is retained until it is reset (for possible errors see Chapter 16.6.2).

12.3.5.2.2 Material data

The first 15 bytes and byte 63 (Last_Error) correspond to the layout of the system data.

Bytes 0...63	Name	Type of data	Function
Byte 0	TableSelect	USINT	Content of read data: 0 = system data, 1 = material data

Bytes 0...63	Name	Type of data	Function
Byte 1 Bit 0: MSB	Bit 0: ADC error Bit 1: above max. + still permissible range (OVL) Bit 2: above max. (FSD) Bit 3: below zero Bit 4: zero $\pm 1/4$ d Bit 5: within zero set range (ZSR) Bit 6: weight is stable Bit 7: weight above max. (FSD) and below overload	BOOL	
Byte 2	Bit 0: trigger material data reading Bit 1: change calibration Bit 2: tare Bit 3: reserved Bit 4: reserved Bit 5: power failure (power fail) Bit 6: within menu [Set-up]/[Configuration] Bit 7: filling mode	BOOL	Bit 0: Reading of material data was triggered by the fieldbus. Bit 1: Calibrate weighing point. Bit 2: Set tare of the instrument. Bit 5: After a power failure the bit is set and can be reset by bit 0 in byte 2. Bit 6: Filling is not possible within the menu items. Bit 7: status-controlled: 0 = fill, 1 = empty
Byte 3	Bit 0: error in the application Bit 1: filling is active Bit 2: system ready Bit 3: filling stopped Bit 4: coarse flow Bit 5: fine flow Bit 6: calming time Bit 7: tolerance alarm	BOOL	Bit 0: Error bit was set. Bit 1: The filling phase is active. Bit 2: The system is ready for filling. Bit 3: Filling was stopped. Bit 4: System is filling: coarse flow bit is set. Bit 5: System is filling: fine flow bit is set. Bit 6: The bit is set according to the set calming time. Bit 7: alarm if tolerance is above/below set point
Byte 4...7	Gross	DINT/REAL	Weight
Byte 8...11	Net	DINT/REAL	Weight
Byte 12...15	Tare	DINT/REAL	Weight
Byte 16	Material ID	BYTE	Current material ID

Bytes 0...63	Name	Type of data	Function
Byte 17	Reserved		
Byte 18...35	Material name	STRING_18	Current material name
Byte 36...39	Set point	DINT/REAL	Current set point
Byte 40...43	Preset	DINT/REAL	Current set point
Byte 44...47	Material overshoot (OVS)	DINT/REAL	Current set point
Byte 48...51	Calming time	DINT	Current set point
Byte 52...55	Tolerance above set point	DINT/REAL	Current set point
Byte 56...59	Tolerance below set point	DINT/REAL	Current set point
Byte 60...62	Reserved		
Byte 63	"Last_Error" error		The last error number is retained until it is reset (for possible errors see Chapter 16.6.2).

13 SPM

13.1 General information

The memory accessible to the user is the SPM (Scratch Pad Memory). This memory is used to store lots of internal data from which weights, statuses and reports can be read and control data can be written.

The SPM table can be accessed via OPC and ModBus communication and fieldbus with SPM interface.

In addition, individual bits are copied back and forth between digital inputs and outputs and the SPM via the I/O configuration.

Note:

If a text is defined e.g. from SPM address B401, this must be defined in the OPC server from SPM address B400 so that the content actually begins at B401.

13.2 Elementary data types

The elementary data types are characterized by their bit width and possible value range. All commands of the data type BOOL are executed with a rising edge.

Data type	Description	Value range
BOOL	bool	0 (FALSE) or 1 (TRUE)
SINT	short integer	-128 to 127
INT	integer	-32768 to 32767
DINT	double integer	-2^{31} to $2^{31}-1$
LINT	long integer	-2^{63} to $2^{63}-1$
USINT	unsigned short integer	0 to 255
UINT	unsigned integer	0 to 65535
UDINT	unsigned double integer	0 to $2^{32}-1$
ULINT	unsigned long integer	0 to $2^{64}-1$
REAL	real number	$\pm 1.18\text{E}-38$ bis $3.4\text{E}38$ (with approx. 7 significant digits)
LREAL	long real number	$\pm 1.18\text{E}-308$ bis $3.4\text{E}308$ (with approx. 16 significant digits)
TIME	time duration	1 ms to $\pm 2^{47}$ ms
DATE	date (only)	1.1.1900 to 31.12.2099
TIME_OF_DAY	time of day (only)	00:00:00.00 to 23:59:59.99
DATE_AND_TIME	Date and time of day	see DATE and TIME_OF_DAY
STRING	variable-long character string	max. 255 characters (ISO)

Data type	Description	Value range
WSTRING	variable-long wide character string	max. 255 characters (Unicode)
BYTE	bit-sequence 8	...
WORD	bit-sequence 16	...
DWORD	bit-sequence 32	...
LWORD	bit-sequence 64	...

13.3 Addressing

The SPM table can be addressed via different counts. Bit addressing is used to count the individual bits (MX). Byte addressing is used to count individual bytes (MB), whereby, e.g. bits MX0...MX7 are identical to byte MB0.

Code	Data type	Address example
%ML	LWORD	L21
%MD	DINT	D42...43
%MW	WORD	W84...87
%MB	BYTE	B168...175
%MX	BOOL (bit)	X1344...1407

13.4 System data

SPM address	Data type	R/W	Function
X0...X2	BOOL	R	Digital input 1...3
X8...10	BOOL	R	Digital output 1...3
X16...18	BOOL	R	Standard only: Output limit 1...3
B4	BYTE	R	Indicator status
X32	BOOL	R	ADC error
X33	BOOL	R	> Max (FSD = Full Scale Deflection)
X34	BOOL	R	> Max + permitted range (OVL)
X35	BOOL	R	< zero
X36	BOOL	R	Zero $\pm 1/4$ d
X37	BOOL	R	Within the zeroset range (ZSR)
X38	BOOL	R	The weight is stable
X39	BOOL	R	Weight < zero or > Max (FSD = Full Scale Deflection)

SPM address	Data type	R/W	Function
B5	BYTE	R	ADC status
X40	BOOL	R	Measuring signal negative (error 7)
X41	BOOL	R	Measuring signal >36 mV (error 3)
X42	BOOL	R	Internal arithmetic error; CAL data are perhaps faulty (error 1)
X43	BOOL	R	No or too low sense voltage (error 6)
X44	BOOL	R	No communication with xBPI scale (error 9)
B6	BYTE	R	Command status
X48	BOOL	R	Command error
X49	BOOL	R	Command active
X50	BOOL	R	Network failure signal
B7	BYTE	R	Active status
X56	BOOL	R	Test mode active
X57	BOOL	R	Calibration active
X58	BOOL	R	Instrument is tared
X59	BOOL	R	Pendeo/Connexx only: parameter [Unbal. check deviat.]
X60	BOOL	R	Pendeo/Connexx only: operation with a simulated load cell
X64	BOOL	R/W	Standard only: Read/write marker bit 1
X65	BOOL	R/W	Standard only: Read/write marker bit 2
X66	BOOL	R/W	Standard only: Read/write marker bit 3
X72	BOOL	R/W	Switch D11 to net weight.
X112	BOOL	W	Zero device.
X113	BOOL	W	Tare device
X114	BOOL	W	Reset the tare of the device
X115	BOOL	W	Start the test mode
X116	BOOL	W	Finish the test mode
X117	BOOL	W	Reset the power fail signal
X118	BOOL	W	Set fixed tare weight D31 as tare
X119	BOOL	W	Store the current gross weight in the preset tare memory (D31)
X120	BOOL	W	EasyFill only: Start printout. Standard only: Weight report
X121	BOOL	W	Reset error B19 = 0.
X123	BOOL	W	Read out current time and date.
X124	BOOL	W	Save (set) current time and date.
B16	SINT	R	Exponent Number of decimal places Example: 1.23 is displayed Exponent: 2
B17	SINT	R	Weight unit 1 = mg, 2 = g, 3 = kg, 4 = t, 5 = lb, 9 = oz

SPM address	Data type	R/W	Function
B18	SINT	R	Verification interval (for multi-interval/multi-range = d1 or e1)
B19	BYTE	R	Last weighing point error, see Chapter 16.6.1 .
B20	BYTE	R	Higher byte of product code (0x54)
B21	BYTE	R	Lower byte of product code (0x10)
B22	BYTE	R	Major part of version number (1.0)
B23	BYTE	R	Minor part of version number (1.0)
D6	UDINT	R	Serial number (board number)
W14	INT	R	Counter will be increased for every measured value.
D8	DINT	R	Current gross weight
D9	DINT	R	Current net weight
D10	DINT	R	Current tare weight
D11	DINT	R	Current gross/net weight selected with X72
D14	DINT	R	Max weight (FSD = Full Scale Deflection)
D15	DINT	R	Min weight
D16	DINT	R	Report: Gross weight
D17	DINT	R	Report: Net weight
D18	DINT	R	Report: Tare weight
D19	DINT	R	Report: Sequence number
D20	DINT	R	Application-independent: Flow value (weight change•100/minute) if no BCD card is installed. Standard only: BCD value for "transparent" mode
D21	DINT	R	Report: Date
D22	DINT	R	Report: Time, BCD display
D23	DINT	R	Activity counter, test of communication with device
D24	DINT	R	Standard only: Limit: Limit 1 on
D25	DINT	R	Standard only: Limit: Limit 1 off
D26	DINT	R	Standard only: Limit: Limit 2 on
D27	DINT	R	Standard only: Limit: Limit 2 off
D28	DINT	R	Standard only: Limit: Limit 3 on
D29	DINT	R	Standard only: Limit: Limit 3 off
D30	UDINT	R/W	Standard only: Analog output for "transparent" mode
D31	DINT	R/W	Preset tare memory (X118, X119)

SPM address	Data type	R/W	Function
B144	BYTE	R	EasyFill only: Batching status 1
X1152	BOOL	R	Batching active
X1153	BOOL	R	Batching ready (ready/idle)
X1154	BOOL	R	Batching is in error state
X1155	BOOL	R	The setup menu of the scale is active.
B145	BYTE	R	EasyFill: Batching status 2
X1160	BOOL	R	Batching in progress
X1161	BOOL	R	Batching stopped
X1162	BOOL	R	Coarse flow
X1163	BOOL	R	Fine flow
X1164	BOOL	R	Calming
X1165	BOOL	R	Tolerance alarm
B146	BYTE	W	EasyFill only: Batching command 1
			Start batching with the current record:
X1168	BOOL	W	Start/Restart
X1169	BOOL	W	Stop/Cancel
			Load a defined material and start in one step:
X1170	BOOL	W	Start ID 1
X1171	BOOL	W	Start ID 2
X1172	BOOL	W	Start ID 3
X1173	BOOL	W	Start ID 4
X1174	BOOL	W	Start ID 5
X1175	BOOL	W	Start ID 6
B147	BYTE	W	EasyFill only: Batching command 2
X1176	BOOL	W	Start ID 7
X1177	BOOL	W	Start ID 8
X1178	BOOL	W	Start ID 9
X1179	BOOL	W	Start ID 10
X1180	BOOL	W	Print report
X1181	BOOL	W	Reset error status D67 = 0
B148	BYTE	W	EasyFill only: Batching command 3
X1182	BOOL	W	Load selected material
X1183	BOOL	W	Save selected material
B149	BYTE	R/W	EasyFill only: Batching modes (1 = B1; 4 = B4)
W76	DINT	R/W	EasyFill only: Material ID
B156...173	BYTE	R/W	EasyFill only: Material name for ID1...10
D44	DINT	R/W	EasyFill only: Set point
D45	DINT	R/W	EasyFill only: Preset
D46	DINT	R/W	EasyFill only: Material overshoot (OVS)
D47	DINT	R/W	EasyFill only: Calming time [ms]
D48	DINT	R/W	EasyFill only: Tolerance below set point
D49	DINT	R/W	EasyFill only: Tolerance above set point

SPM address	Data type	R/W	Function
W104 (B209)	WORD	R	EasyFill only: Report: Material ID
B212...229	BYTE	R	EasyFill only: Report: Material name
D58	DINT	R	EasyFill only: Report: Batched weight
D59	DINT	R	EasyFill only: Report: Set point
D60	DINT	R	EasyFill only: Report: Preset
D61	DINT	R	EasyFill only: Report: Material overshoot (OVS)
D62	DINT	R	EasyFill only: Report: Calming time [ms]
D63	DINT	R	EasyFill only: Report: Tolerance below set point
D64	DINT	R	EasyFill only: Report: Tolerance above set point
D67	DINT	R	EasyFill only: "Last_Error" error, see Chapter 16.6.2
OPC server only			
R264	REAL	R	Gross weight (as floating point number)
R265	REAL	R	Net weight (as floating point number)
R266	REAL	R	Tare weight (as floating point number)
R267	REAL	R	Current gross/net weight selected with X72 (as floating point number)
R270	REAL	R	Max weight (FSD = Full Scale Deflection) (as floating point number)
R271	REAL	R	Min weight (as floating point number)
R272	REAL	R	Report: Gross weight (as floating point number)
R273	REAL	R	Report: Net weight (as floating point number)
R274	REAL	R	Report: Tare weight (as floating point number)
R280	REAL	R	Standard only: Limit: Limit 1 on (as floating point number)
R281	REAL	R	Standard only: Limit: Limit 1 off (as floating point number)
R282	REAL	R	Standard only: Limit: Limit 2 on (as floating point number)
R283	REAL	R	Standard only: Limit: Limit 2 off (as floating point number)
R284	REAL	R	Standard only: Limit: Limit 3 on (as floating point number)
R285	REAL	R	Standard only: Limit: Limit 3 off (as floating point number)
R287	REAL	R/W	Write the value in the preset tare memory (as floating point number).
L17	LWORD	W	SPM out
X1088...1151	BOOL	R	Output
L18	LWORD	W	SPM out AND coarse
X1152...1215	BOOL	R	Output and coarse
L19	LWORD	W	SPM out AND fine
X1216...1279	BOOL	R	Output and fine

Note:

The system variables (e.g. ST_WGT_A) for communication via OPC are described in operating instructions PR 1792 (Chapter 4 + 5).

Example:

Production start

Write material parameters (D44...D49).

Start batching (X1168).

Monitor status (B144, B145).

Once batching is complete, read report data.

14 Repairs and maintenance

14.1 Repairs

Repairs are subject to inspection and must be carried out at Minebea Intec.

In case of defect or malfunction, please contact your local Minebea Intec dealer or service center for repair.

When returning the device for repair, please include a precise and complete description of the problem.

It is only permitted to replace fuses in accordance with Chapter [14.1.3](#).

14.1.1 Battery for date/time

The lithium battery (5) for backing up the calendar/time chip is located beside the power supply on the main board (under the cover; see Chapter [4.5.1](#)).

The lithium battery for backing up the calendar/time chip is located on the main board.

The battery is activated before the device leaves the factory.

Note:

After initial start-up, the date and time must be checked and set if necessary under  - [Date&Time].

14.1.2 Changing the battery for date/time

The device is equipped with a lithium battery for backing up the time/calendar chip. If the voltage drops below the specified minimum, or in case of defect, the battery must be replaced by Minebea Intec customer service or by an equivalent trained technician.

The battery is activated by setting the date and time under  - [Date&Time].

For disposal information, see Chapter [15](#).

For battery lifespan, see Chapter [17.3.1](#).

14.1.3 Replacing fuse

⚠ WARNING**Explosion possible if replacement is not done correctly!**

- ▶ It is only permitted to replace fuses in the PR 5410 when used in the ex area, if the atmosphere is not potentially explosive.
 - ▶ Only the fuses listed in Chapter [17.3.3](#) are permissible.
-

⚠ WARNING**Working on the device while it is switched on may have life-threatening consequences.**

When removing covers or parts using tools, live parts or terminals may be exposed. Please note that capacitors in the device may still be charged even after disconnecting the device from all voltage sources.

- ▶ Disconnecting the device from the power supply.
-

1. Disconnect device from the electrical supply.
2. Remove the cover from the device.
3. Open in-line fuse holder (unscrew).
4. Remove old fuse and insert new fuse.
5. Close fuse holder.
6. Re-seal the device with the cover.

14.2 Maintenance

Maintenance work may only be carried out by a trained technician with expert knowledge of the hazards involved and the required precautions.

14.3 Soldering work

Soldering work on the device is neither required nor permitted.

14.4 Cleaning

NOTICE

Property damage caused by unsuitable cleaning utensils/agents.

Damage to the device.

- ▶ Prevent moisture from penetrating the interior.
- ▶ Do not use aggressive cleaning agents (solvents or similar agents).
- ▶ For use in the food industry, use a cleaning agent suitable for that particular working environment.
- ▶ Use soft sponges, brushes and cloths.
- ▶ Spraying with water or blasting with compressed air is not permitted.

1. Unplug device from mains supply, disconnect any data cables.
2. Clean the device with a cloth lightly moistened with a soap solution.
3. Wipe down the device with a soft, dry cloth after cleaning.

15 Disposal

Our products and their packaging should not be disposed of in municipal waste (e.g. garbage can for recyclable packaging, garbage can for paper packaging, etc.). They can either be recycled by the customer themselves, providing this complies with requirements set out by electrical or electronic waste or packaging waste laws, or sent back to Minebea Intec at a charge.

This option of returning the product is intended to provide proper recycling or reuse in a manner that is collected separately from municipal waste.

Before disposing of or scrapping the old products, any single-use or rechargeable batteries should be removed and taken to a suitable collection point. The type of battery used is specified in the technical data.

Please see our General Terms and Conditions for further information.

Service addresses for repair acceptance and collection points can be found on the product information enclosed with the product as well as on our website (www.minebea-intec.com).

Should you have any further questions, please contact your local service representative or our service center.

Minebea Intec GmbH

Repair center

Meiendorfer Strasse 205 A

22145 Hamburg, Germany

Phone: +49.40.67960.333

service.HH@minebea-intec.com

We reserve the right not to accept products that are contaminated with hazardous substances (ABC contamination).

16 Error messages



16.1 Error messages measuring circuit

The internal weighing electronics can generate error messages, which are shown on the weight display.

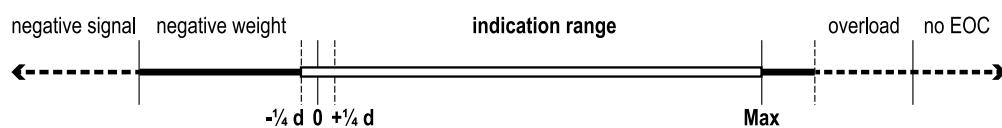
Display	VNC text	Error and possible cause
Error 1	Arith. error	Internal arithmetic overflow: - Faulty calibration values.
Error 2	Overload	The measuring signal is higher than Max + (x d): - Wrong setting. - Too much weight on the scale.
Error 3	Ext. meas. device error	Measuring input open: - The measuring signal is higher than the permissible range of 36 mV. - Measuring cable is interrupted (cable break detection). - Other hardware defect.
Error 4	Value exceeds display	The weight value is not displayed: - Too many digits have been set.
Error 6	No sense voltage	No sense voltage: - Load cells not connected. - Sense line or supply line is interrupted. - Wrong polarity or sense voltage is low.
Error 7	Negative input	Negative measuring signal: - Wrong polarity of load cell signal. - Wrong polarity of load cell supply voltage.
Error 9	No values from scale	Internal weighing point: The measuring signal is higher than the permissible range of 36 mV. Cannot read weight values from ADC (analog-digital converter). - Error in weighing electronics board. - Defective load cell. - Cable break.



16.2 Error messages for xBPI scales

Display	VNC text	Error and possible cause
Error 3	Ext. meas. device error	No weight values can be read from scale: - Scale error
Error 4	Value exceeds display	The weight value is not displayed: - Too many digits have been set.
Error 9	No values from scale	No communication with xBPI scale: - Cable break. - Internal scale error. - The scale is not connected to the power supply.
Error 11	No weight data	No weight display: - Another weighing point was selected. Press  to assign the new weighing point to the device. Requirements:  - [Serial ports parameter] - [xBPI port] - [Slot 1/2 RS 485] is selected.
Error 12	Scale not ready	The scale is not ready for weighing: - The device is in the warm-up phase. - The device is in automatic taring mode. - The device was switched on with the scale loaded. Switch the device off and on again.
Error 15	Wrong serial number	Serial number of scale does not match the number set in the device.







16.3 Error messages for Pendeo load cells

Display	VNC text	Error and possible cause
Error 2	Overload	The measuring signal is higher than Max + (x d): - Wrong setting. - Too much weight on the scale.
Error 4	Value exceeds display	The weight value is not displayed: - Too many digits have been set.
Error 8	Incompatible units	Incompatible units: - Incorrect calibration values e.g. due to incorrect calibration

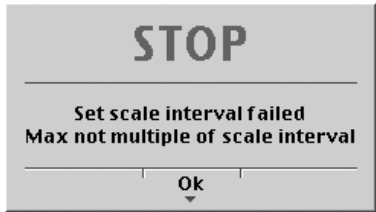
Display	VNC text	Error and possible cause
Error 9	No values from scale	No communication with Pendeo load cell: <ul style="list-style-type: none"> - Cable break. - Internal scale error. - The junction box is not connected to the supply voltage.
Error 12	Scale not ready	The scale is not ready for weighing: <ul style="list-style-type: none"> - At least 1 load cell gives an error status or is defective (no communication).
Error 13	Wrong configuration	The number of load cells does not match the configuration.
Error 15	Wrong serial number	Serial number of scale does not match the number set in the device.

16.4 Error messages during calibration

Message	Possible causes
<p>The screenshot shows a grey background with the word 'STOP' in large letters at the top. Below it, the text 'Set Max failed above physmax' is displayed. At the bottom, there is an 'Ok' button with a downward arrow.</p>	This message displays, if the maximum load is too high.
<p>The screenshot shows a grey background with the word 'STOP' in large letters at the top. Below it, the text 'Set Max failed below calibration' is displayed. At the bottom, there is an 'Ok' button with a downward arrow.</p>	The maximum load of the scale can be increased retroactively. When the capacity is reduced, however, a message is displayed when the new maximum load is lower than the CAL weight ([Calibrated at]).
<p>The screenshot shows a grey background with the word 'STOP' in large letters at the top. Below it, the text 'Set Max failed not enough d' is displayed. At the bottom, there is an 'Ok' button with a downward arrow.</p>	This message is displayed if the selected resolution is too low, e.g., 5 kg.
<p>The screenshot shows a grey background with the word 'STOP' in large letters at the top. Below it, the text 'Set Max failed too many digits' is displayed. At the bottom, there is an 'Ok' button with a downward arrow.</p>	This message is displayed if the selected resolution is so high that less than 0.8 internal counts per scale interval (d) and/or 0.5 $\mu\text{V}/\text{e}$ are available if legal-for-trade acc. to OIML/NSC.

Message	Possible causes
 <p>STOP</p> <p>Set scale interval failed Max not multiple of scale interval</p> <p>Ok</p>	<p>This message displays if the maximum load is not an integer multiple of the scale interval.</p>
 <p>STOP</p> <p>Set Max failed incompatible units</p> <p>Ok</p>	<p>Weight units don't match, e.g., subsequent change for [Max] from kg into lb.</p>
 <p>STOP</p> <p>Set deadload failed above physmax</p> <p>Ok</p>	<p>This message is displayed when the dead load entered in mV/V plus scale interval in mV/V is higher than 3 mV/V (= 36 mV).</p>
 <p>STOP</p> <p>Set deadload failed no standstill</p> <p>Ok</p>	<p>This message displays, if the scale is not stable.</p> <p>Remedy</p> <ul style="list-style-type: none"> - Check the mechanical function of the scale. - Adapt the filter setting; reduce the resolution. - Adapt the standstill conditions.
 <p>STOP</p> <p>Set deadload failed deadload below -0.1 mV/V</p> <p>Ok</p>	<p>This message is displayed when the measurement signal is negative when determining the dead load with [by load].</p> <p>Cause</p> <p>Load cell connected with wrong polarity, or defective.</p>
 <p>STOP</p> <p>Set deadload failed overflow in arithmetics</p> <p>Ok</p>	<p>This message is displayed when the dead load entered is >5 mV/V.</p>
 <p>STOP</p> <p>Set SPAN failed No stability</p> <p>Ok</p>	<p>This message displays, if the scale is not stable.</p> <p>Remedy</p> <ul style="list-style-type: none"> - Check the mechanical function of the scale. - Adapt the filter setting; reduce the resolution. - Adapt the standstill conditions.

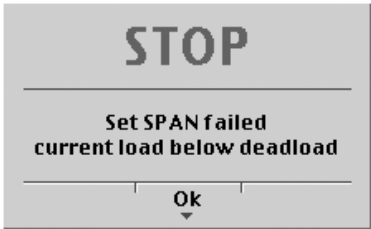
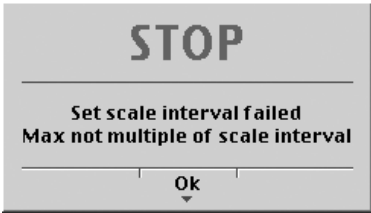
Message	Possible causes
 <p>STOP</p> <p>Set SPAN failed current load below deadload</p> <p>Ok</p>	This message is displayed if the weight on the scale is < the dead load after input of the weight value.
 <p>STOP</p> <p>Set scale interval failed Max not multiple of scale interval</p> <p>Ok</p>	The maximum capacity is not an integer multiple of the scale interval.

16.5 General error messages

Display	Error and Possible Cause
Err 21	BIOS is too old for the firmware.
Err 22	Firmware is too old for the BIOS.
Err 23	Boot not possible: <ul style="list-style-type: none"> - ROM error - No firmware found
Err 25	Plug-in card combination is not permissible.
Err 29	"Flash" process has failed.
Err 31	The digit group for IP address/mask is not within 0–255, or is invalid.
Err 32	The IP address is already in use. Two instruments with identical IP addresses.
Err 33	Wrong parameter
Err 34	No Ethernet cable (LINK) found
Err 41	Major system error
Err 42	Major system error in controls.
Err 43	Monitoring time has expired.
Err 44	Cannot save to EAROM.
Err 45	Cannot load from EAROM.
Err 46	Wrong access code
Err 51	DeviceNet: Not all DIL switches are set to "ON."
Err 52	The selected optional card does not exist.
Err 53	The selected interface is in use.

Display	Error and Possible Cause
Err 61	CAL switch is closed.
Err 62	Calibration cannot be started.
Err 63	The weighing point parameters could not be saved.
Err 64	The default SPAN could not be set.
Err 66	Weighing point is in use.
Err 67	Weighing point is not tared.
Err 68	No mechanical stability of the scale.
Err 69	Weighing point is not in use.
Err 70	Tare is active.
Err 71	A weight error occurs during calibration via the front panel if the connection to the weighing point is interrupted.
Err 72	This message is displayed for internal weighing point <ul style="list-style-type: none"> - during the warm-up phase. - when the device is in the automatic taring mode. - if the device has been switched on with the scale loaded. Switch the device off and on again.
Err 73	Dead load < -0.1 mV/V
Err 74	Arithmetic overflow
Err 75	Current weight < dead load
Err 76	Value for "d" is too high.
Err 77	Value for "d" is too low.
Err 78	Max < calibration weight.
Err 79	The weight cannot be displayed with the desired unit.
Err 80	Dead load + Max is too high.
Err 81	Max and scale interval do not match (1, 2, 5 10, 20, or 50).
Err 82	Not sufficient $\mu\text{V}/\text{d}$ for W&M (legal-for-trade).
Err 83	Digital filter: Measurement time >160 ms.
Err 84	Filter frequency: Measurement time <40 ms/ F_{cut} .
Err 85	Filter frequency F_{cut} is >40.00 Hz
Err 86	xBPI weighing point is selected. This weighing point can only be calibrated via VNC.
Err 87	Sequence no. was not found in alibi memory.
Err 88	Sequence no. cannot be changed because the alibi memory is activated.
Err 89	No EW-Com interface assigned.

Display	Error and Possible Cause
Err 90	No printer interface assigned.
Err 91	Linearization is active.
Err 92	xBPI interface cannot be opened.
Err 93	Too many Pendeo load cells were found.
Err 94	Search for Pendeo load cells is defective.
Err 95	Communication error with Pendeo load cells.
Err 96	Not all Pendeo load cells are the same type.
Err 97	Dead load cannot be set for Pendeo load cells.
Err 98	Weighing point cannot be assigned to the Pendeo load cell.
Err 99	xBPI communication is not assigned.

16.6 Error numbers @ "LAST_ERROR"

16.6.1 Weighing point error

Number	Display	Cause
2	in use	Weighing point is in use, e.g., by an application.
6	test active	Test is active, no weights.
7	cali active	Calibration is active, no weights.
8	no standstill	No standstill of the scale.
13	tare is active	Tare is active.
15	weight is dimmed	Weight is not legal-for-trade (<0 or >max.).
16	weight has error	Weight error.
17	scale not ready	Scale is not ready.
18	cannot tare below zero	Taring below zero is not possible.
102	timeout	Only on xBPI scales: Time limit exceeded when sending a command to the scale.
142	calibration active	During calibration, taring and zeroing is not possible.
147	no zeroset	Zeroset outside of the zero setting range is not possible.
149	Busy	The scale is currently busy with another query.
255	hardware error	Weighing point is faulty.

16.6.2 Error in the "EasyFill" application

Number	Display	Cause
0		No error.
1	fatal error	Weight error; weighing point is faulty.

Number	Display	Cause
2	Material ID invalid	Number <0 or >10 entered.
3	Material name invalid	Material name is invalid.
4	Set point invalid	Set point + gross value > scale end value, (B1 mode) or gross value.
5	Preset point invalid	Value > set point.
6	OVS invalid	Value > set point.
8	Neg. tol. invalid	Value > set point.
9	Pos. tol. invalid	Value > set point.
10	Sequence number invalid	Sequence number is invalid.
13	Invalid fieldbus command	Fieldbus action is invalid (e. g., simultaneous start and stop command).
15	Cannot read from earom	Error when reading a material entry from the hard drive memory (EAROM) → hardware error
16	Cannot write to earom	Error when writing a material entry to the hard drive memory (EAROM) → hardware error
17	Action not allowed	Fieldbus action is not permitted. Example: Starting filling during an ongoing filling process or starting filling when querying the system setup.
18	Weight unit of material invalid	The unit of the weighing point does not match the unit of the material.

17 Technical data

17.1 Note on using "free software"

The firmware on the PR 5410 device contains "free software" that is licensed under the

- GNU General Public License (GPL) Version 2, June 1991, and
- GNU Lesser General Public License (LGPL) Version 2.1, February 1999.

This "free software" developed by third parties is copyrighted and is provided free of charge. The license terms and conditions of Free Software Foundation, Inc. in English are included in the delivery of the device. The source text for the terms and conditions can be found on the CD-ROM included.

17.2 Decoding the serial number

30 252 00015		
30	252	00015
Location no.: 30 = Hamburg	Code for the year/month: 252* = April 2010	Current number

* Is increment according to the year group table of Minebea Intec.

17.3 General data

The following characteristics are valid after a warm-up time of at least 60 minutes (reference temperature 23 °C).

17.3.1 Backup for date/time

The lithium battery for backing up the date/time chip is activated before the instrument leaves the factory.

Lifespan	Device continuously connected to mains voltage	up to 10 years
	Device not connected to mains voltage for some time (e.g. in storage)	up to 7 years

17.3.2 Supply voltage connection 230 V AC

Supply voltage	$U_{AC} = 100$ to 240 V	+10%/-15%, 50/60 Hz
Max. power consumption	11 W/13 VA	
Primary fuse	800 mA; 5 × 20 mm;	

17.3.3 Supply voltage connection 24 V DC

Supply voltage	$U_{DC} = 24$ V	±20%
Max. power consumption	11 W	
Primary fuse	1,6 AT; 250 V AC; 5×20 mm Littlefuse, order number: 021801.6 MXP	

17.4 Effect of ambient conditions

17.4.1 Ambient conditions

Temperature range	Reference temperature	23 °C
	Ambient temperature for operation	-10...+50 °C
	Ambient temperature "verifiable"	-10...+40 °C
	Power-on temperature	0...+50 °C
	Limits for storage/transport	-20...+70 °C
Moisture	<95%, non-condensing (acc. to IEC 60068-2)	
Protection class	Housing: IP30 Front panel: IP65	
Height	<2000 m	

17.4.2 Electromagnetic Compatibility (EMC)

All data in compliance with NAMUR NE 21, EN 45501 and EN 61326.

Housing	High frequency electromagnetic fields (80...1000 MHz)	EN 61000-4-3	10 V/m
	Electrostatic discharge (ESD)	EN 61000-4-2	6/8 kV
Signal and control lines	Fast transients (burst)	EN 61000-4-4	1 kV
	Peak voltages (surge) 1.2/50 µs	EN 61000-4-5	1/2 kV
	Conducted disturbances by high frequency coupling (0.15...80 MHz)	EN 61000-4-6	10 V
Mains inputs	Fast transient disturbances (Burst)	EN 61000-4-4	2 kV
	Peak voltages (surge) 1.2/50 µs	EN 61000-4-5	1/2 V
	Conducted disturbances by high frequency coupling (0.15...80 MHz)	EN 61000-4-6	10 V
	Voltage dips	EN 61000-4-11	0/40% 20/200ms
	Mains failure link	EN 61000-4-11	20 ms

17.4.3 RF interference suppression

Interference emission



pursuant to EN 61326, Limit class A, for industrial areas

17.5 Weighing electronics

The weighing electronics are suitable for connection of strain-gauge load cells.

17.5.1 Load cells

Load cell type	Strain gage load cells	6 or 4-wire connection possible.
Supply voltage	$U_{DC} = 12\text{ V}$	<ul style="list-style-type: none"> - for $I_{max} = 160\text{ mA}$ - for max. 8 load cells, each with $650\ \Omega$ - for max. 4 load cells, each with $350\ \Omega$
Sense voltage monitoring		Sense voltage below $U_{DC} = +4\text{...}-4\text{ V}$ will be detected. Can be switched off via software
Max. load	$\geq 75\ \Omega$	

17.5.2 Principle

Principle	Direct current, Delta-Sigma converter, ratiometric to supply voltage
Conversion time/measurement time	5, 10, 20, 40, 80, 160, 320, 640, 960, 1200, 1600 ms
Digital filter	Can be activated, active 4th order (low-pass) Characteristics: Bessel, aperiodic, Butterworth, Tschebyscheff
Cut off frequency	adjustable

17.5.3 Accuracy and stability

Accuracy*	0.5 $\mu\text{V}/\text{e}$ corr. to 3 mV for 6000 e 0.5 $\mu\text{V}/\text{e}$ corr. to 5 mV for 10,000 e Class III, according to OIML R76/EN45501
Min. measuring signal (OIML)*	6,000 e: $\geq 0.25\text{ mV}/\text{V}$ 10,000 e: $\geq 0.42\text{ mV}/\text{V}$
Linearity*	$< 0.003\ \%$
Zero point stability error (TK ₀)*	$< 0.05\ \mu\text{V}/\text{K RTI}$; $\leq 0.004\ \%/10\text{K}$ at 1 mV/V
SPAN stability error (TK _{span})*	$< \pm 2.5\ \text{ppm}/\text{K}$

* at a measurement time of 160 ms.

17.5.4 Sensitivity

Sensitivity	0.5 $\mu\text{V}/\text{e}$ @ 10,000 e (class III); OIML R76
Max. resolution	7.5 million internal counts at 3 mV/V
Measurement input (measuring signal + dead load)	$U_{\text{DC}} = 0 \dots \text{max. } 36 \text{ mV}$, symmetrical to zero
Dead load suppression	max. measuring signal of $U_{\text{DC}} = 36 \text{ mV}$ (dead load + range); entry/calibration via software

17.5.5 Connecting cables

Length of the connecting cable between junction box and instrument

Cable type	PR 6135, PR 6135A	max. 500 m – length of the load cell cable
------------	-------------------	--

Length of the connecting cable between weighing platform and instrument

Cable type	LiYCY	max. 500 m
------------	-------	------------

17.6 Mechanics

17.6.1 Design

Metal housing made of aluminum with steel cover and rear panel, protection class IP65 (front).

17.6.2 Weights

Net weight	1.45 kg
Shipping weight	2.00 kg

17.7 Documentation on the CD included

The documents and manuals listed in the appendix (see Chapter [18.3](#)) can be found on the PR 5410 CD.

18 Appendix

18.1 Replacement parts

Spare part no.	Spare part designation
5322 530 51247	Sealing
5312 447 98010	Sealing only for PR 5410/04
5312 256 98006	Retaining bracket set, including screws
5312 264 58019	I/O connector, 7-pin
5312 447 98009	Optional plates with screws
5312 505 18020	Knurled head screw set for retaining brackets
5312 216 98373	Display circuit board with display
5312 216 98368	Mainboard 230 V
5312 216 98369	Mainboard 24 V
5312 264 48017	Connector, 6-pin
5312 280 78004	Converter 230 V-24 V

18.2 Test connector

for the RS-232 interface

Pin assignment

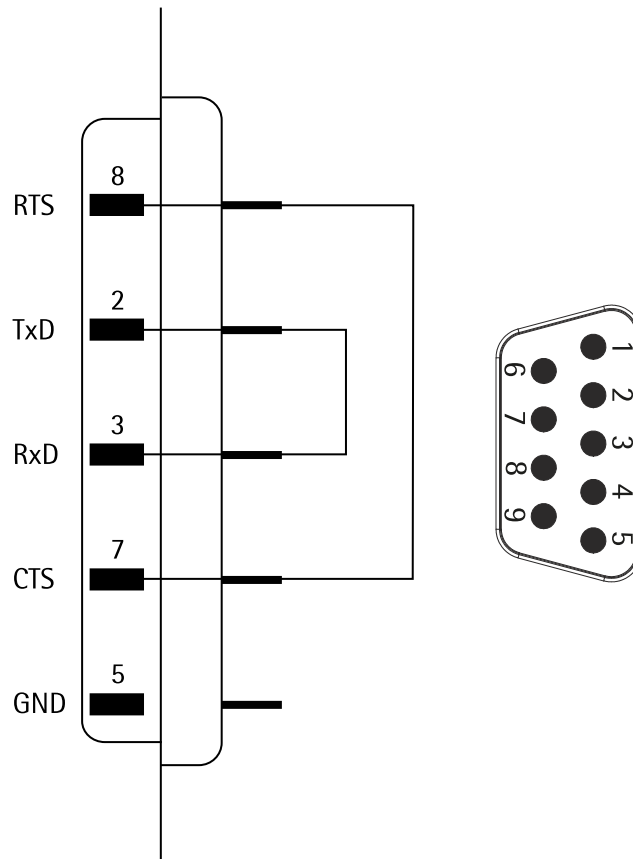

18.3 Certificates

Ser. no.	Description	Document no.
1	EU-Declaration of Conformity	MEU17028
2	Declaration of Conformity	MDC17004
3	Test Certificate PTB	D09-07.54
4	EC-type-approval Certificate NMi	T7884
5	EU-type examination Certificate NMi	T11379
6	EU-type examination Certificate NMi	T10529
7	Evaluation Certificate NMi	TC11543
8	OIML Certificate of Conformity NMi	R51/2006-NL1-13.02
9	Certificate of Conformance NTEP	18-038
10	Certificate of Compliance	E478290

The documents listed in the table can be found on the PR 5410 CD.

Published by
Minebea Intec GmbH | Meiendorfer Strasse 205 A | 22145 Hamburg, Germany
Phone: +49.40.67960.303 | Email: info@minebea-intec.com
www.minebea-intec.com

