

Installation Manual

Process Controller Maxxis 4 PR 5500



Foreword

Must be followed!

Any information in this document is subject to change without notice and does not represent a commitment on the part of Minebea Intec unless legally prescribed. This product should only be operated/installed by trained and qualified personnel. In correspondence concerning this product, the type, name, and release number/serial number as well as all license numbers relating to the product have to be cited.

Note

This document is partially protected by copyright. It may not be changed or copied, and it may not be used without purchasing or written permission from the copyright owner (Minebea Intec). The use of this product constitutes acceptance by you of the abovementioned provisions.

Table of contents

1	Introduction	4
1.1	Read the manual	4
1.2	This is what operating instructions look like	4
1.3	This is what lists look like	4
1.4	This is what menu items and softkeys look like	4
1.5	This is what the safety instructions look like	4
1.6	Hotline	5
2	Safety instructions	6
2.1	General notes	6
2.2	Intended use	6
2.3	Initial inspection	6
2.4	Before operational startup	6
2.4.1	Installation	7
2.4.2	Opening the device	7
2.4.3	Supply voltage connection	7
2.4.4	Protective ground connection	8
2.4.5	24 V DC fuse	8
2.4.6	RF interference suppression	8
2.4.7	Failure and excessive stress	9
2.4.8	Important note	9
2.4.9	Repairs and maintenance	9
3	Process controller	10
3.1	General notes	10
3.2	Overview of the device	10
3.2.1	Communication protocols	11
3.3	Housing	12
3.3.1	Housing dimensions	12
3.3.2	Housing dimensions with strain relief and reinforcing frame	13
3.3.3	Control panel cut-out	14
3.4	Overview of device front	14
3.5	Overview of connections	15
3.5.1	Plug-in cards	16
3.5.2	Application licenses	18
3.6	Device description	18
3.6.1	Combinations for options	18
3.6.2	Device version marking	20
4	Device installation	21
4.1	General notes	21

4.2	Mechanical preparation.....	21
4.3	EMC-compliant installation	22
4.3.1	Connecting the screens to the screen clamping rail.....	22
4.3.2	Connecting the equipotential bonding conductor	22
4.4	Hardware construction	23
4.4.1	Main board.....	23
4.4.2	LEDs	24
4.4.3	Network port.....	25
4.4.4	USB connection	26
4.4.5	SD card slot	29
4.4.6	RS-232 interface (internal).....	29
4.5	Accessories	34
4.5.1	PR 5500/04 2x RS-485 interface.....	34
4.5.2	PR 5500/32 2x RS-232 interface.....	45
4.5.3	PR 5500/07 analog input and output	49
4.5.4	PR 5500/10 weighing electronics board.....	52
4.5.5	PR 5500/12 digital inputs and outputs	64
4.5.6	PR 5500/13 digital inputs and outputs	70
4.5.7	PR 5500/17 digital inputs and outputs	76
4.5.8	ProfiBus DP interface	84
4.5.9	DeviceNet interface	87
4.5.10	CC-Link interface	91
4.5.11	ProfiNet I/O interface.....	93
4.5.12	EtherNet/IP interface	98
5	Maintenance/repairs/soldering work/cleaning	102
5.1	Maintenance.....	102
5.2	Repairs.....	102
5.2.1	Battery for date/time	102
5.2.2	Rechargeable battery for power supply.....	102
5.2.3	Exchanging the plug-in cards	103
5.2.4	Replacing the SD card	105
5.2.5	Replacing the device	105
5.3	Soldering work.....	107
5.4	Cleaning	107
6	Disposal	108
7	Technical data.....	109
7.1	Note on using "free software"	109
7.2	Decoding the serial number.....	109
7.3	General data	109
7.3.1	Backup for date/time	109

7.3.2	Rechargeable battery for power supply.....	109
7.3.3	Display	109
7.3.4	Supply voltage connection 230 V AC.....	110
7.3.5	Supply voltage connection 24 V DC.....	110
7.4	Effect of ambient conditions	110
7.4.1	Ambient conditions	110
7.4.2	Electromagnetic Compatibility (EMC).....	110
7.4.3	RF interference suppression	111
7.5	Mechanics	111
7.5.1	Design.....	111
7.5.2	Dimensions	111
7.5.3	Weights.....	111
7.6	Use in legal metrology	111
7.6.1	Documentation relating to calibration on the CD included	111
7.6.2	Further information	111
8	Appendix	112
8.1	Certificates.....	112

1 Introduction

1.1 Read the manual

- Please read this manual carefully and completely before using the product.
- This manual is part of the product. Keep it in a safe and easily accessible location.

1.2 This is what operating instructions look like

1. - n. are placed before steps that must be done in sequence.
 - ▶ is placed before a step.
 - ▷ describes the result of a step.

1.3 This is what lists look like

- indicates an item in a list.

1.4 This is what menu items and softkeys look like

[] frame menu items and softkeys.

Example:

[Start]- [Applications]- [Excel]

1.5 This is what the safety instructions look like

Signal words indicate the severity of the danger involved when measures for preventing hazards are not followed.

DANGER

Warning of personal injury

DANGER indicates death or severe, irreversible personal injury which will occur if the corresponding safety measures are not observed.

- ▶ Take the corresponding safety precautions.

WARNING

Warning of hazardous area and/or personal injury

WARNING indicates that death or severe, irreversible injury may occur if appropriate safety measures are not observed.

- ▶ Take the corresponding safety precautions.

CAUTION

Warning of personal injury.

CAUTION indicates that minor, reversible injury may occur if appropriate safety measures are not observed.

- ▶ Take the corresponding safety precautions.

NOTICE**Warning of damage to property and/or the environment.**

NOTICE indicates that damage to property and/or the environment may occur if appropriate safety measures are not observed.

- ▶ Take the corresponding safety precautions.
-

Note:

User tips, useful information, and notes.

1.6 Hotline

Phone: +49.40.67960.444

Fax: +49.40.67960.474

eMail: help@minebea-intec.com

2 Safety instructions

2.1 General notes

CAUTION

Warning of personal injury.

This device has been built and tested in compliance with the safety regulations for measuring and control equipment for protection class I (protective grounding conductor) according to IEC 1010/EN 61010 or VDE 0411.

The device was in perfect condition with regard to safety features when it left the factory.

- ▶ To maintain this condition and to ensure safe operation, the user must follow the instructions and observe the warnings in this manual.

2.2 Intended use

The device is exclusively intended for use in weighing and dosing systems, and is particularly suitable for tank and vessel scales, truck scales, platform scales, crane scales, dosing systems and as a weight indicator in intelligent control systems.

Product operation, commissioning and maintenance must be performed by trained and qualified personnel who are aware of and able to deal with the related hazards and take suitable measures for self-protection.

The device reflects the state of the art.

No warranty is given that the product is free of faults, especially not in conjunction with third-party software and hardware components required for operation.

The manufacturer does not accept any liability for damage caused by third-party system components or due to incorrect use of the product. The use of this product signifies recognition of the stipulations listed above.

2.3 Initial inspection

Check the contents of the consignment for completeness. Check the contents visually to determine whether any damage has occurred during transport. If there are grounds for rejection of the goods, a claim must be filed with the carrier immediately. The Minebea Intec sales or service organization must also be notified.

2.4 Before operational startup

NOTICE

Perform visual inspection.

- ▶ Before operational startup as well as after storage or transport, inspect the device visually for signs of mechanical damage.
- ▶ Before operational startup, acceptance of the installation by an authorized expert is compulsory.

2.4.1 Installation

The device has to be installed in an EMC-compliant manner, see Chapter [4.3](#).

Setup

Version	Protection class	Installation
Control cabinet housing	IP65, rear IP20	Control panel cut-out

To ensure proper cooling of the device, make sure air circulation around the device is not blocked. Avoid exposing the instrument to excessive heat, e.g. from direct sunlight. The ambient conditions in Chapter [7.4.1](#) must be taken into account at all times.

With outdoor mounting, make sure that adequate weather protection is provided (for temperatures, see Chapter [7.4.1](#)).

2.4.2 Opening the device

⚠ WARNING

Working on the device while it is switched on may have life-threatening consequences.

When removing covers or parts using tools, live parts or terminals may be exposed. Please note that capacitors in the device may still be charged even after disconnecting the device from all voltage sources.

- ▶ Disconnecting the device from the power supply.

This device contains electrostatically sensitive components. For this reason, an equipotential bonding conductor must be connected when working on the open device (antistatic protection).

2.4.3 Supply voltage connection

2.4.3.1 Version 230 V AC



Safe interruption of both supply voltage conductors must be provided for, either by disconnecting the power connector or using a separate switch.

The device is protected via two fuses (see Chapter [7.3.4](#)) on the back of the device (primary side).

The device is equipped with a wide range power supply and covers AC systems with a frequency of 50/60 Hz and a voltage range of $U_{AC} = 100$ to 240 V $-15/+10\%$ automatically (without manual selection).

The power supply is protected against short circuits and overloads, and disconnects automatically in case of a fault. If the electrical protection has triggered:

- Disconnect the device from all power sources and wait at least 1 minute.
- Determine and eliminate the cause of the error.
- Reconnect the device to the supply voltage.

2.4.3.2 Version 24 V DC



This version is designed for $U_{DC} = 24\text{ V}$.
The supply is established via three spring terminals of the (+ PE -). The device is protected against incorrect polarity.

2.4.4 Protective ground connection

2.4.4.1 Version 230 V AC

The device must be connected to a protective ground via a protective grounding conductor (PE) in the network plug.

The power cable contains a protective grounding conductor which must not be interrupted inside or outside the device.

The protective grounding conductor is connected to the back of the housing inside the device.

2.4.4.2 Version 24 V DC



The protective grounding conductor must be clamped in the middle terminal (PE).

2.4.5 24 V DC fuse

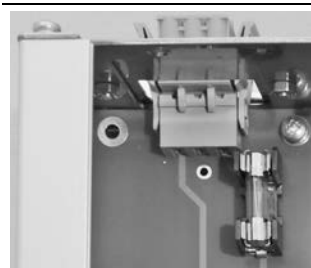

The device is protected in the + line via a fuse (see Chapter [7.3.5](#)) on the primary side in the device.

2.4.6 RF interference suppression

The device is intended for use in an industrial environment. Operation of this device in a residential environment is likely to cause radio frequency interference, see Chapter [7.4.3](#). In this case, the operator may be required to take appropriate measures.

2.4.7 Failure and excessive stress

If there is any reason to assume that safe operation of the device is no longer ensured, shut it down and make sure it cannot be used.

Safe operation is no longer ensured if any of the following is true:

- The device is physically damaged.
- The device does not function.
- The device has been subjected to stresses beyond the tolerance limits (e.g., during storage or transport).

2.4.8 Important note

Make sure that the construction of the device is not altered to the detriment of safety. In particular, leakage paths, air gaps (of live parts) and insulating layers must not be reduced.

Minebea Intec cannot be held responsible for personal injury or property damage caused by a device repaired incorrectly by an operator or installer.

2.4.9 Repairs and maintenance

2.4.9.1 General information

Repairs are subject to inspection and must be carried out at Minebea Intec.

In case of defect or malfunction, please contact your local Minebea Intec dealer or service center for repair.

When returning the device for repair, please include a precise and complete description of the problem.

Maintenance work may only be carried out by a trained technician with expert knowledge of the hazards involved and the required precautions.

2.4.9.2 Electrostatically sensitive parts

This device contains electro-statically sensitive components. Therefore, potential equalization must be provided when working on the device (antistatic protection).

2.4.9.3 Replacing fuses

WARNING

Damage from overheating.

The use of repaired fuses and bypassing the fuse holder is prohibited.

- Only the fuses listed in chapters [7.3.4](#) and [7.3.5](#) are permissible.

3 Process controller

3.1 General notes

The device is equipped with a TFT color graphics display and a function/alphanumeric keypad.

With the corresponding application, this device is a powerful system for managing/documenting weighing and dosing processes. It combines the functions of a user-friendly interface as well as a weighing and dosing device, PLC and interfaces.

The device is programmable according to the IEC 61131-3 standard and the PR 1750/60 development tool accessory is also available.

3.2 Overview of the device

- Accuracy 10,000 d at 0.5 $\mu\text{V}/\text{d}$ for the weighing electronics
- High-speed conversion with measurement times from 5 msec
- Weight display with status and mass unit on a TFT color display
- Housing for installation in a control cabinet. Protection class IP65 for the front, otherwise IP20
- Integrated LAN connection (10/100 Mbit/s) for, e.g., data transmission
- Integrated USB 2.0 connection (Type A, $i = 200 \text{ mA}$) for printer, USB stick, PC keyboard, barcode scanner, external splitter (hub)
- SD card slot (incl. SD card)
- Integrated RS-232 interface for, e.g., PC, printer or remote display
- Can be expanded using the following plug-in cards:
 - Interface card 2x RS-485 PR 5500/04
 - Analog I/O interface card PR 5500/07
 - Weighing electronics board PR 5500/10 (W1)
 - Digital I/O interface card PR 5500/12
 - Digital I/O interface card PR 5500/13
 - Digital I/O interface card PR 5500/17
 - Interface card 2x RS-232 PR 5500/32
 - Fieldbus cards PR 1721/6x or PR 1721/7x (2-port versions)
- Wide range power supply for $U_{AC} = 100$ to 240 V, protection class I (protective grounding conductor)
- Version for $U_{DC} = 24 \text{ V}$
- Plug-in connections inside the device for load cells, inputs/outputs, LAN connection, serial interfaces
- Alternative operation using PC tool (browser/VNC)
- Calibration using weights according to the mV/V method or directly using load cell data (smart calibration)
- Software configuration of the interface cards, e.g., for remote display or printer

- Analog test for the weighing electronics
- Overwrite protection:
 - Via a maximum of 3 CAL switches (two on the main board and one on the weighing electronics board)
 - Via software

3.2.1 Communication protocols

For the internal RS-232:

- Remote display protocol
- Printer
- ModBus protocol
- xBPI protocol
- SBI protocol
- EW-Com protocol

Field bus slave (accessories):

- PR 1721/61 ProfiBus-DP
- PR 1721/64 DeviceNet
- PR 1721/65 CC-Link
- PR 1721/66 ProfiNet I/O
- PR 1721/67 EtherNet-IP
- PR 1721/76 ProfiNet I/O 2-port
- PR 1721/77 EtherNet-IP 2-port

For the internal LAN interface:

- ModBus-TCP
- Ethernet TCP/IP
- OPC-UA, refer to the corresponding documentation

3.3 Housing

3.3.1 Housing dimensions

The keypad and the display form one unit with the front. A rectangular cut-out is required for the installation. Cable connections are made at the back of the housing.

Front view

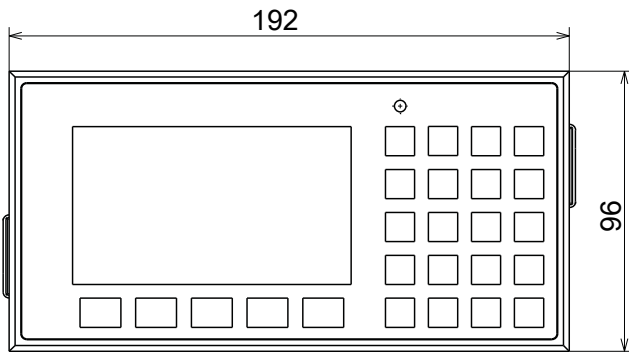

All dimensions in mm

Side view

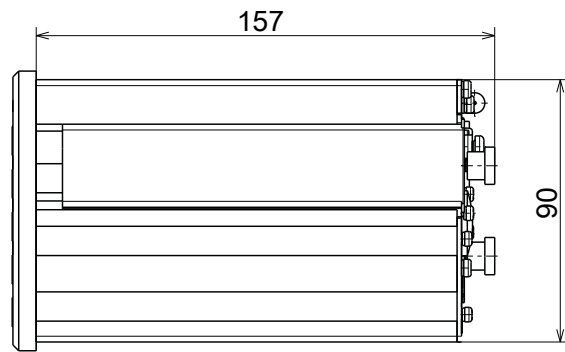

All dimensions in mm

Back view

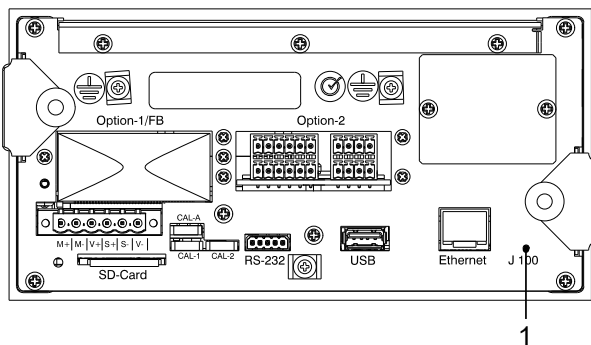

No. Description

1 Reset key

3.3.2 Housing dimensions with strain relief and reinforcing frame

Front view

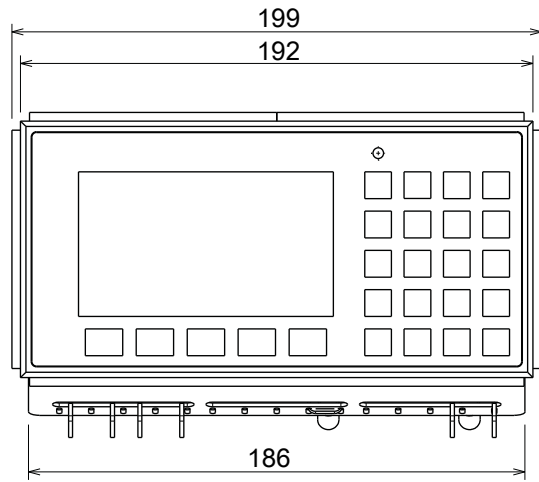

All dimensions in mm

Side view

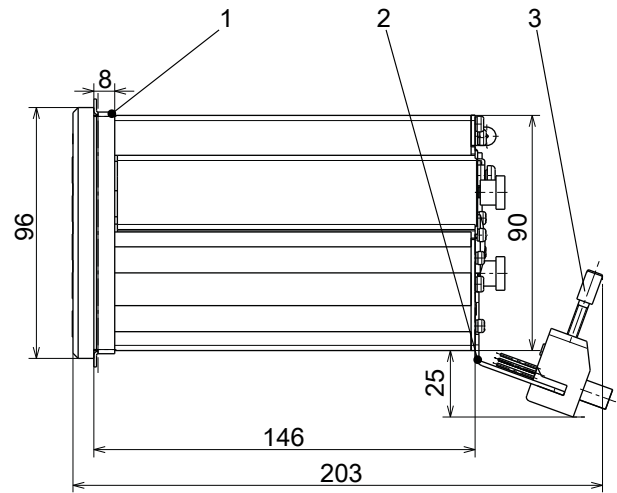

All dimensions in mm

Back view

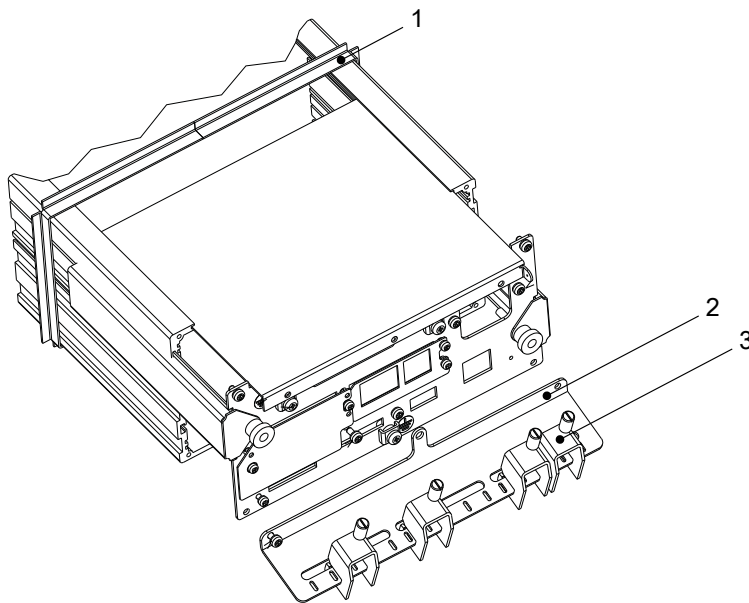

The dimensions with the options listed in the table must be observed during installation:

No.	Description
1	Reinforcing frame
2	Screen clamping rail
3	Screen clamp

3.3.3 Control panel cut-out

The control panel cut-out must be created before the device is installed.



All dimensions in mm

3.4 Overview of device front

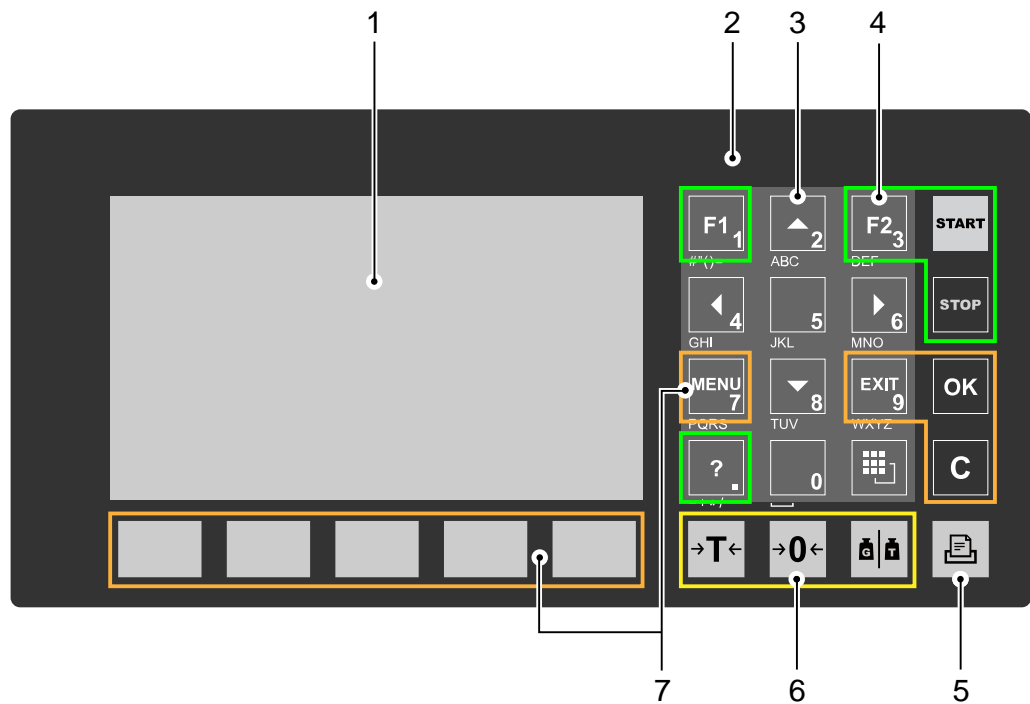

Display and operating elements

No.	Description
Display elements	
1	4.3" color display
2	LED status display
Operating elements	
3	Alphanumeric keys Navigation keys (key 2, 4, 6, 8)
4	Function keys

No.	Description
5	Application keys
6	Indicator keys
7	Menu keys, incl. softkeys

For a description of the display and operating elements, refer to Chapter "Display and operating elements" in the PR 5500 operating instructions.

3.5 Overview of connections

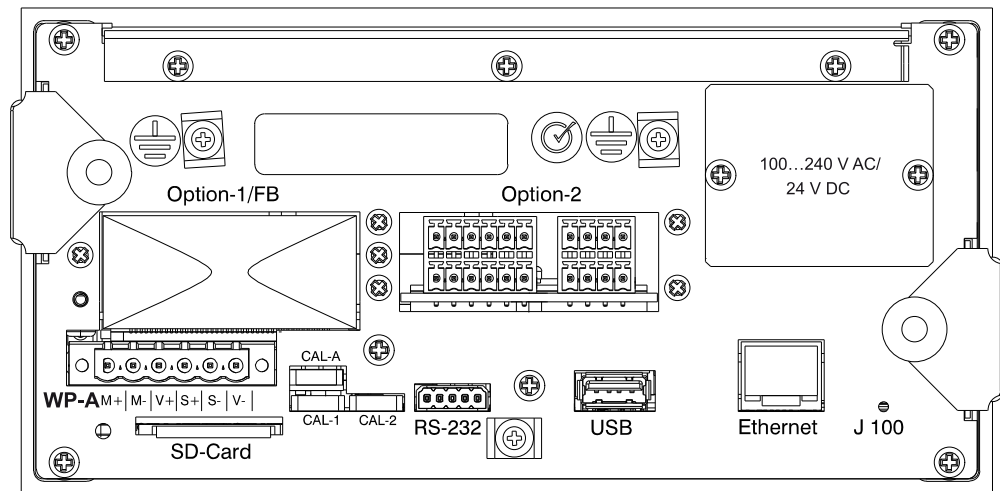

Connection	Description
Option 1/FB Fieldbus interfaces, only one option	<ul style="list-style-type: none"> - ProfiBus DP PR 1721/61 - DeviceNet PR 1721/64 - CC-Link PR 1721/65 - ProfiNet I/O PR 1721/66 - EtherNet IP PR 1721/67 - ProfiNet I/O 2-port PR 1721/76 - EtherNet-IP 2-port PR 1721/77
Option 1 Interfaces	<ul style="list-style-type: none"> - Option 1 and/or option 2: Serial connections RS-485 (2x) PR 5500/04
Option 2 Interfaces	<ul style="list-style-type: none"> - Option 1 and/or option 2: Serial connections RS-232 (2x) PR 5500/32 One channel can be used for connecting to an IS platform without an external power supply. - Option 1 and/or option 2: Analog inputs/outputs PR 5500/07 - Option 1 and/or option 2: Digital inputs/outputs PR 5500/12, PR 5500/13, PR 5500/17

Connection	Description
Ethernet LAN interface (internal)	<ul style="list-style-type: none"> - Remote operation via VNC - Software updates - Communication/data exchange: OPC, ModBus-TCP External I/O devices: <ul style="list-style-type: none"> - ModBus-TCP - Printer
RS-232 Serial interface RS-232 (internal)	<ul style="list-style-type: none"> - Printer - Remote display - External scales
USB USB 2.0 connection (internal)	<ul style="list-style-type: none"> - USB stick - USB keyboard - USB barcode reader - USB printer
SD card SD card slot (internal)	An SD card is used for extra storage and not to transfer data
WP A	WP A: Internal weighing point PR 5500/10 (W1)

3.5.1 Plug-in cards

Product	Description	Position
PR 5500/04 2 x RS-485 serial inter- faces	The interface can be configured by software. For more information, see Chapter 4.5.1 .	Option-1/FB and/or Option-2
PR 5500/07 1 analog input 1 analog output	Analog input: internal 14 bits binary = 20,000 counts, @ e.g. 0...20 mA/0...10 V Analog output: internal 16 bits = 65,536 counts, resolution of 20,000 @ 20 mA For more information, see Chapter 4.5.3 .	Option-1/FB and/or Option-2
PR 5500/10 (W1) Weighing electronics	Internal weighing electronics for connecting load cells or weighing platforms in non-Ex areas. For more information, see Chapter 4.5.4 .	WP A
PR 5500/12 4 digital inputs 4 digital outputs	4 passive opto-decoupled inputs 4 relay outputs with potential-free change- over contacts For more information, see Chapter 4.5.5 .	Option-1/FB and/or Option-2

Product	Description	Position
PR 5500/13 4 digital inputs 4 digital outputs	4 active opto-decoupled inputs 4 relay outputs with potential-free change-over contacts For more information, see Chapter 4.5.6 .	Option-1/FB and/or Option-2
PR 5500/17 6 digital inputs 8 digital outputs	6 passive opto-decoupled inputs 8 passive opto-decoupled outputs For more information, see Chapter 4.5.7 .	Option-1/FB and/or Option-2
PR 5500/32 2 RS-232 serial interfaces	The interface can be configured by software. For more information, see Chapter 4.5.2 .	Option-1/FB and/or Option-2
PR 1721/61 ProfiBus-DP	ProfiBus DP V0 slave with 9.6 kbit/s...12 Mbit/s, baud rate auto-detection For more information, see Chapter 4.5.8 .	Option-1/FB (Connection card installed rotated)
PR 1721/64 DeviceNet	DeviceNet master-slave with 125, 250, and 500 kbit/s For more information, see Chapter 4.5.9 .	Option-1/FB (Connection card installed rotated)
PR 1721/65 CC-Link	CC-Link master-slave with 10 Mbit/s For more information, see Chapter 4.5.10 .	Option-1/FB (Connection card installed rotated)
PR 1721/66 ProfiNet I/O	ProfiNet I/O with 10 Mbit/s and 100 Mbit/s, auto-detection (10/100, HalfDX/FullDX) For more information, see Chapter 4.5.11 .	Option-1/FB (Connection card installed rotated)
PR 1721/67 EtherNet IP	EtherNet IP with 10 Mbit/s and 100 Mbit/s, auto-detection (10/100, HalfDX/FullDX) For more information, see Chapter 4.5.12 .	Option-1/FB (Connection card installed rotated)
PR 1721/76 ProfiNet I/O 2-port	ProfiNet I/O with 10 Mbit/s and 100 Mbit/s, auto-detection (10/100, HalfDX/FullDX) For more information, see Chapter 4.5.11 .	Option-1/FB (Connection card installed rotated)
PR 1721/77 EtherNet IP 2-port	EtherNet IP with 10 Mbit/s and 100 Mbit/s, auto-detection (10/100, HalfDX/FullDX) For more information, see Chapter 4.5.12 .	Option-1/FB (Connection card installed rotated)

3.5.2 Application licenses

Examples of application licenses:

Type	Function
PR 5500/92	PR 1792 OPC server (incl. AccessIt 2.0 license)
PR 5500/83	Batching

Examples of application packages:

Counting, checkweighing, totalizing

Automatic dosing and manual filling

For product details, see corresponding data sheets/manuals.

Applications purchased from Minebea Intec may only be changed as per a source code agreement.

3.6 Device description

3.6.1 Combinations for options

Housing:

Designation	Code no.	Description	Chap.
Control cabinet housing		Default	3.3.1

Housing attachment parts:

Designation	Code no.	Chap.
Strain relief for connector cable	L14	3.3.2
Reinforcing frame	L15	3.3.2

Electronics:

Designation	Accessories	Code no.	Description	Chap.
Analog/digital converter	PR 5500/10	W1	WP A: Weighing electronics board	4.5.4

Power supply:

Designation	Code no.	Description	Chap.
Power supply	L0	100 to 240 V AC version	2.4.3.1
	L8	24 V DC version	2.4.3.2

Interface cards:

Designation	Accessories	Code no.	Description	Chap.
2 x RS-485 interface	PR 5500/04	B15	Option 1: 2 serial interfaces	4.5.1
		B25	Option 2: 2 serial interfaces	
Analog inputs and outputs	PR 5500/07	B16	Option 1: 1 analog input and 1 analog output (0/4 to 20 mA)	4.5.3
		B26	Option 2: 1 analog input and 1 analog output (0/4 to 20 mA)	
Digital inputs and outputs	PR 5500/12	B18	Option 1: 4 passive opto-decoupled inputs and 4 relay outputs	4.5.5.1 , 4.5.5.2
		B28	Option 2: 4 passive opto-decoupled inputs and 4 relay outputs	
Digital inputs and outputs	PR 5500/13	B17	Option 1: 4 active opto-decoupled inputs and 4 relay outputs	4.5.6.1 , 4.5.6.2
		B27	Option 2: 4 active opto-decoupled inputs and 4 relay outputs	
Digital inputs and outputs	PR 5500/17	B19	Option 1: 6 passive opto-decoupled inputs and 8 passive opto-decoupled outputs	4.5.7.1 , 4.5.7.2
		B29	Option 2: 6 passive opto-decoupled inputs and 8 passive opto-decoupled outputs	
2 x RS-232 interface	PR 5500/32	B14	Option 1: 2 serial interfaces	4.5.2
		B24	Option 2: 2 serial interfaces	

Fieldbus cards:

Designation	Accessories	Code no.	Description	Chap.
ProfiBus DP	PR 1721/61	C21	1/FB option	4.5.8
DeviceNet	PR 1721/64	C24	1/FB option	4.5.9
CC-Link	PR 1721/65	C25	1/FB option	4.5.10
ProfiNet I/O	PR 1721/66 PR 1721/76	C26	1/FB option	4.5.11
EtherNet/IP	PR 1721/67 PR 1721/77	C27	1/FB option	4.5.12

Applications/alibi memory/OPC server:

Designation	Accessories	Code no.	Description	Chap.
Basic		H0	Application; default	See corresponding manual
Phase	PR 5500/81	I4	Application (incl. OPC license)	
Batching	PR 5500/83	I6	Application	
IBC	PR 5500/86	I11	Application	

Designation	Accessories	Code no.	Description	Chap.
Tilt error correction	PR 5500/87	I12	License (only "Basic" application)	
Alibi memory	PR 5500/91	E5	License	
OPC server	PR 5500/92	E6	Use of the PR 1792 OPC server (incl. AccessIt 2.0 license)	
Batch modes	PR 5500/93	E9	Special license for the use of dosing modules in programming operations	

3.6.2 Device version marking

The device version marking (e.g., PR 5500-W1-L0-C21-B15-B27-H0-E5) (basic device + options) is located on a label on the back of the device.

4 Device installation

4.1 General notes

Before starting work, please read Chapter 2 and follow all instructions.

WARNING

Warning of hazardous area and/or personal injury

- ▶ All cable connections must be protected from damage.

Note:

- Measurement cables should be kept away from power equipment.
- Signal cables and measurement cables should be installed separately from electric power lines.
- It is recommended that measurement cables are laid in separate cable conduits.
- Power cables should be crossed at right angles.

Further procedures:

- Check the consignment: make sure that all components are present.
- Safety check: inspect all components for damage.
- Make sure that the on-site installation is correct and complete including cables, e.g. power cable fuse protection, load cells, junction box, data cables, console/cabinet, etc.
- If necessary, install the plug-in cards (device must be disconnected from all voltage sources).
- Follow all device installation instructions related to application, safety, ventilation, sealing and environmental influences.
- Connect the cable from the junction box or platform/load cell.
- If applicable: connect other data cables, network cables, etc.
- Connect to supply voltage.
- Check the installation.

4.2 Mechanical preparation

Have all required parts, technical documents, and tools at hand for control cabinet installation.

Other procedure:

- Make the control panel cut-out for the device in the control cabinet door, for example; see Chapter [3.3.3](#).
- Install the device.
- Secure the cable at the place of installation, e.g. using cable ties.
- Remove the insulation from the cable ends and keep the strands short.

- Connect the screens to the grounding terminal or the screen clamping rail of the device; see Chapter 4.3.
- Establish grounding/equipotential bonding between devices/system components; see Chapter 4.3.2.

4.3 EMC-compliant installation

4.3.1 Connecting the screens to the screen clamping rail

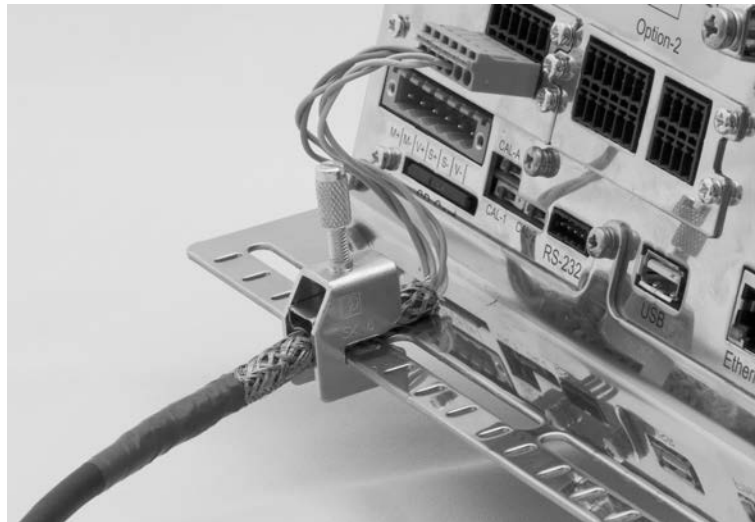

The screens must be connected to the screen clamping rail using cable clamps as pictured or the supplied screen terminals.

4.3.2 Connecting the equipotential bonding conductor



The equipotential bonding conductor (1) must be connected as pictured.

4.4 Hardware construction

4.4.1 Main board

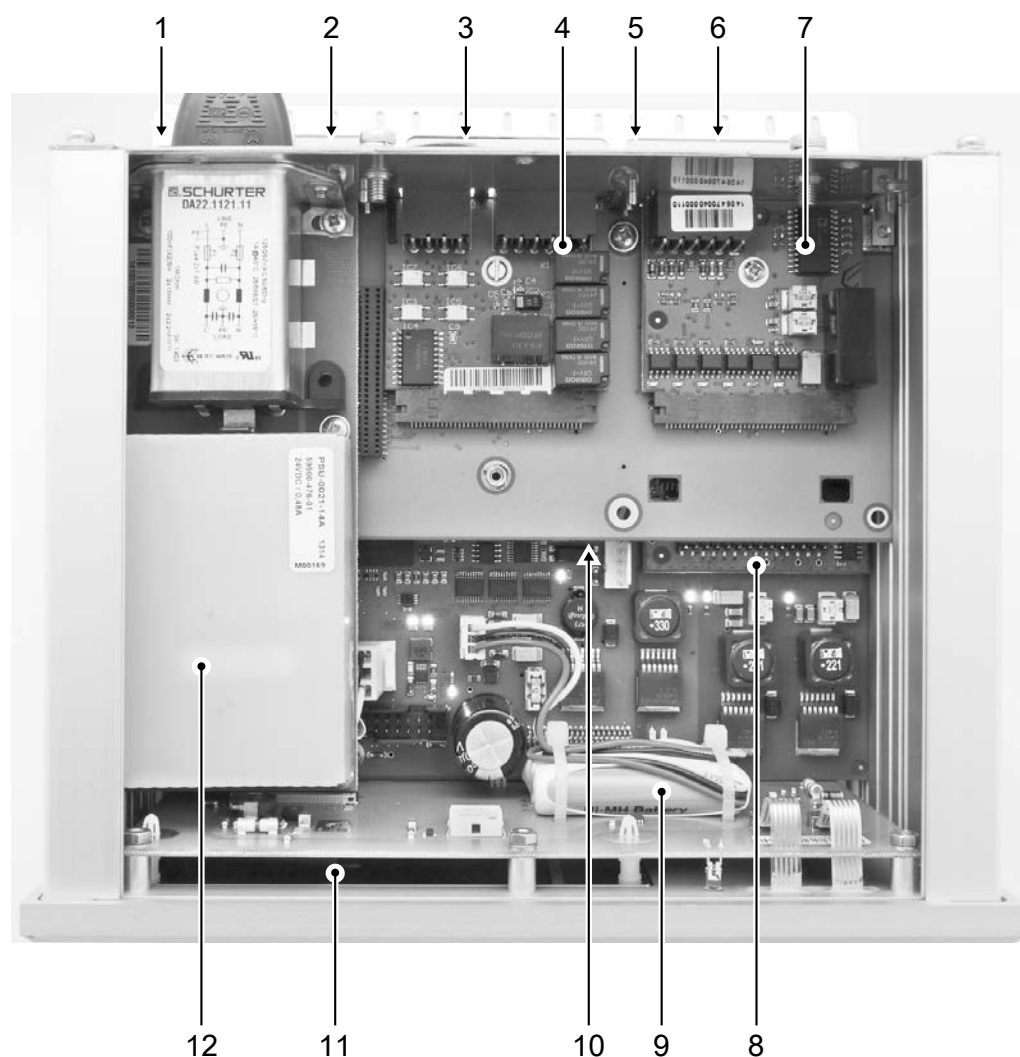

The following elements are located on the main board:

No.	Description
1	Reset key
2	Ethernet port, internal
3	USB connection
4	Slot for optional cards, option 2
5	Connection for RS-232 interface, internal
6	SD card slot
7	Slot for fieldbus and optional cards, option 1/FB
8	Weighing electronics board W1
9	Standby rechargeable battery (for data recovery)
10	Clock battery (see Chapter 5.2.1)

No.	Description
11	Color-graphic display
12	Power supply

The color-graphic display is connected to the main board via a ribbon cable.

4.4.2 LEDs

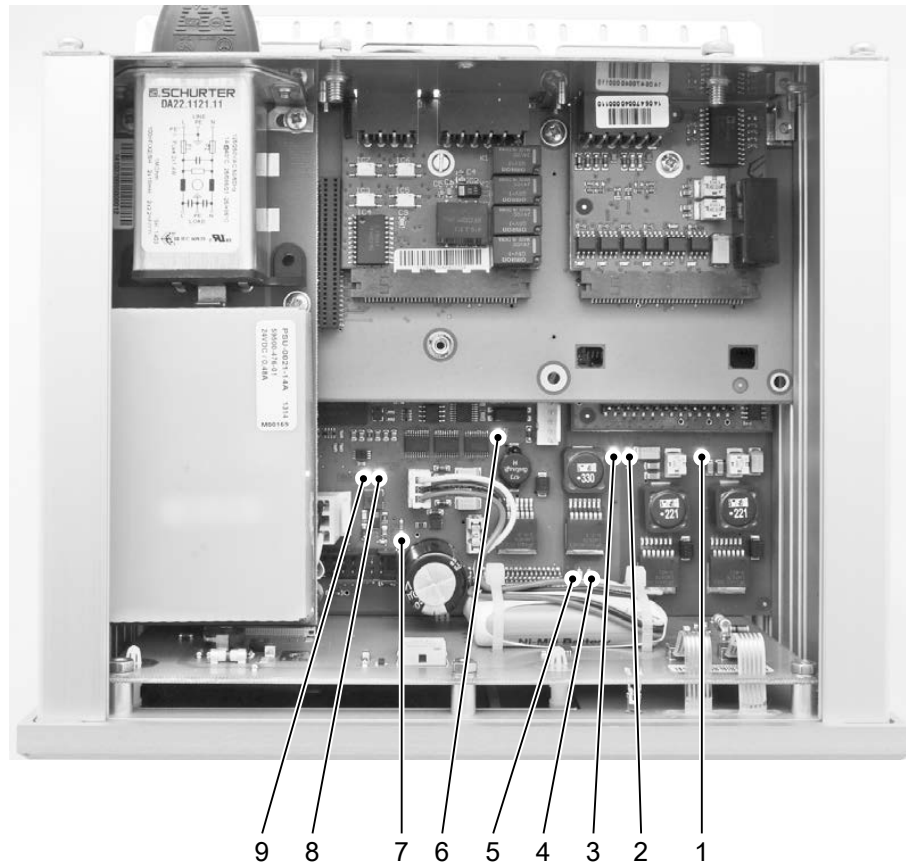

LED	Function
1	ADC supply voltage +9 V
2	ADC supply voltage -9 V
3	5 V
4	300 mA rechargeable battery current, illuminates when charging
5	60 mA rechargeable battery current, illuminates when charging
6	3.3 V
7	Main supply voltage 24 V
8	5 V, buffered
9	3.3 VCC, buffered
10	USB supply (not shown) The LED is located under the connection card for the optional cards.

4.4.3 Network port

The device has an internal Ethernet port.

NOTICE

Damaged data will bring a stop to IT operations.

Protect the IT network to prevent unauthorized access.

► The current IT security guidelines must be followed so as to minimize the risks.

4.4.3.1 Ethernet port

The Ethernet port contains a powerful TCP/IP interface connection with transfer rates of 10 or 100 Mbit/s.

Function tests can be performed via the LEDs (green and yellow) in the RJ-45 socket.

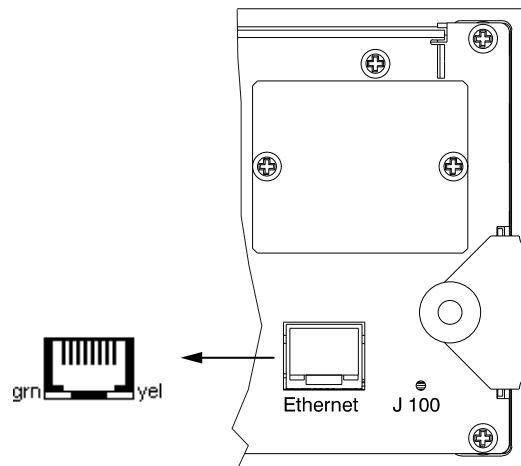

Technical data

Description	Data
Connection 	RJ-45 socket on the device back Green (grn): flashing on data traffic (activity) Yellow (yel): lights up when there is an existing connection (link)
Transfer rate	10 Mbit/s, 100 Mbit/s, full/half duplex, auto-detection
Connection mode	Point to point
Potential isolation	Yes
Cable type	CAT 5 patch cable, twisted pair, screened
Cable impedance	150 Ω
Cable length	Max. 115 m

4.4.3.2 Notebook/PC connection

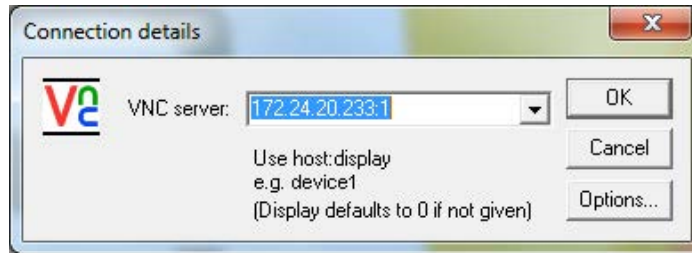

Remote operation of the device from a notebook/PC is possible (install VNC software version 3.3.7* on the notebook/PC).

* Minebea Intec guarantees the functionality only if this version is used.

4.4.4 USB connection

The USB connection is located on the back of the device.



Type	USB 2.0, type A
Max. current	$i_{\max} = 200 \text{ mA}$
Potential connection devices	<ul style="list-style-type: none"> - USB stick; see Chapter 4.4.4.1 - External keyboard; see Chapter 4.4.4.2 - Barcode reader; see Chapter 4.4.4.3 - Printer (not GDI); see Chapter 4.4.4.4 - External splitter (hub); see Chapter 4.4.4.5

⚠ CAUTION

Data integrity cannot be guaranteed in the case of a power failure when using a USB stick via a splitter (HUB).

► Connect the USB stick directly to the USB connection.

4.4.4.1 USB stick

All commercially available USB sticks can be used.

4.4.4.2 External PC keyboard

The device has an alphanumeric keypad and a USB connection for an external PC keyboard on the back of the housing. Both operating functions are equivalent and either one can be used.

⚠ CAUTION

Before connecting the keyboard, make sure: power consumption $i < 200 \text{ mA}$.

► A self-resetting fuse prevents overloads.

Connecting to an external PC keyboard

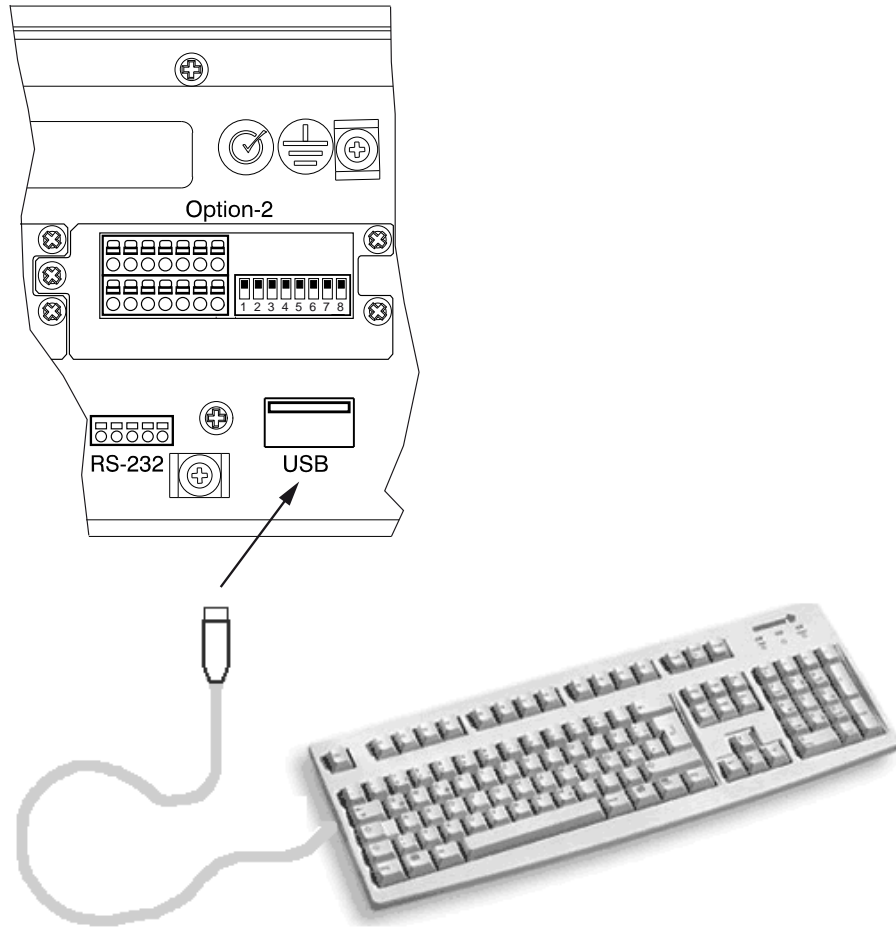

Keyboard layout

PC keyboard										
Keys	F1	F2	?	MENU	Soft key 1	Soft key 2	Soft key 3	Soft key 4	Soft key 5	
PC keyboard										
Keys		START	STOP	EXIT	C	OK	◀	▲	▼	▶

Refer to [System setup] - [Operating parameters] - [USB keyboard layout] in the PR 5500 operating instructions to select the keyboard layout for the connected keyboard:

- [German QWERTZ]
- [French AZERTY]
- [Italian QWERTY]
- [Spanish QWERTY]
- [English QWERTY]
- [Russian QWERTY/йцукен]

4.4.4.3 Barcode scanner

A barcode scanner can be connected to the USB interface on the back of the housing as an alternative to an external keyboard.

⚠ CAUTION

Before connecting the barcode scanner, make sure: power consumption $i < 200$ mA.

► A self-resetting fuse prevents overloads.

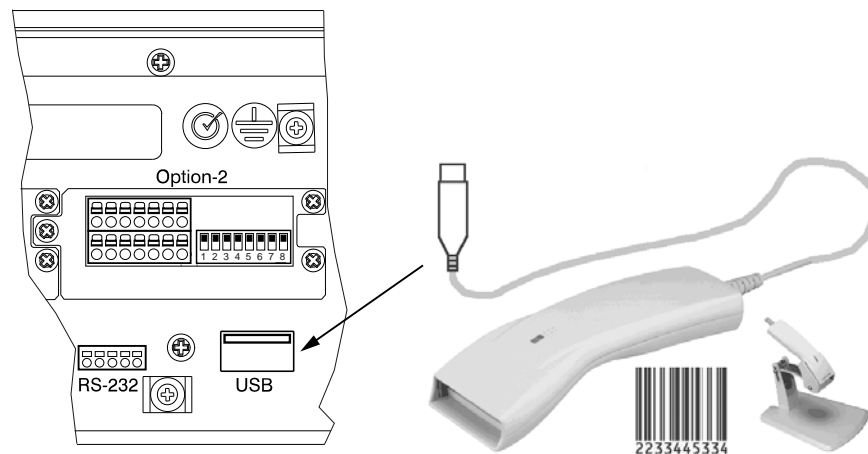

Barcode scanner settings are configured by scanning the corresponding code (see manual). We recommend setting 3 redundant read processes to ensure secure read values.

To confirm each read process via the keypad, the automatic CR function of the reader must be switched off.

4.4.4.4 Printer

The following USB printers can be connected:

- YDP14IS-OCEUV
- EPSON TM-U220 and EPSON LQ-300K
- Line printers
- Printers with ESC/P2 control
- Printers with PCL5 control

4.4.4.5 External HUB

All commercially available HUBs can be connected.

CAUTION

All connected USB devices + HUB: power consumption $i < 200$ mA or use a power supply for the HUB.

- ▶ A self-resetting fuse prevents overloads.

4.4.5 SD card slot

The internal SD card slot is located on the back of the device. It comes with an appropriate SD card. The SD card is only used for storage; it is not used for data transfers.

Note:

Only SD cards supplied by Minebea Intec may be used. No warranty is given for third-party cards.

The following data is saved to the SD card:

- The backup directories for the configuration and database
- A copy of the current version of the BIOS, firmware, and application
- A copy of the version of the BIOS, firmware, and application as delivered
- Manuals

You also have the option of saving application data.

CAUTION

The SD card is a fixed component of the device.

- ▶ The SD card should only be removed together with the SIL chip during servicing (for information on replacing the device, refer to Chapter [5.2.4](#)).
- ▶ The SD card may not be used for data transfers.
- ▶ The SD card may not be used in a notebook/PC.

The SD card is backed up by a rechargeable battery in the event of a power failure, which means that the current activity (e.g., reading data) will be continued and completed.

4.4.6 RS-232 interface (internal)

The device is equipped with an integrated RS-232 interface.

This interface is configurable, and can be used, for example, for data transmission to a remote display or printer.

Connection options using the RS-232 interface:

- Connecting a YDP14IS ticket printer via RS-232; see Chapter [4.4.6.1](#)
- Connecting additional printers; see Chapter [4.4.6.2](#)
- Connecting an IS platform via RS-232; see Chapter [4.4.6.3](#)
- Connecting a Mettler scale via RS-232; see Chapter [4.4.6.4](#)

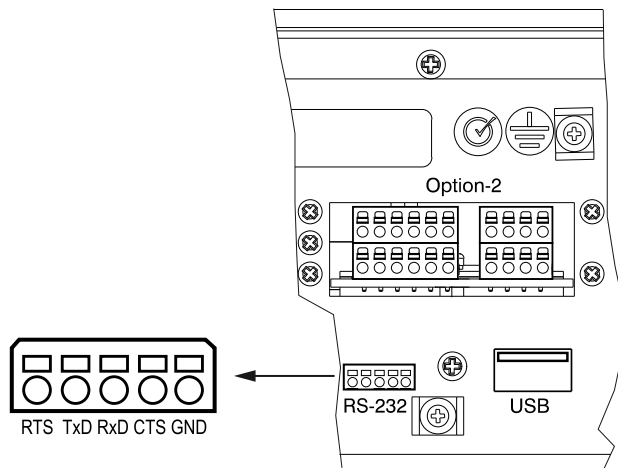

Technical data

Description	Data
Connection	Terminal, 5-pin
Number of channels	1
Type	RS-232, full duplex
Transmission rate [bit/s]	300 to 115K2 bit/s
Parity	None, odd, even
Data bits	7/8
Input signal level	Logic 1 (high) -3 to -15 V Logic 0 (low) +3 to +15 V
Output signal level	Logic 1 (high) -5 to -15 V Logic 0 (low) +5 to +15 V
Number of signals	Input: RxD, CTS Output: TxD, RTS
Potential isolation	None
Cable type	Twisted pair, screened (e.g., LifYCY 3x2x0.20), 1 pair of wires for ground (GND)
Cable gauge	Max. 1.5 mm ²
Cable length	Max.15 m

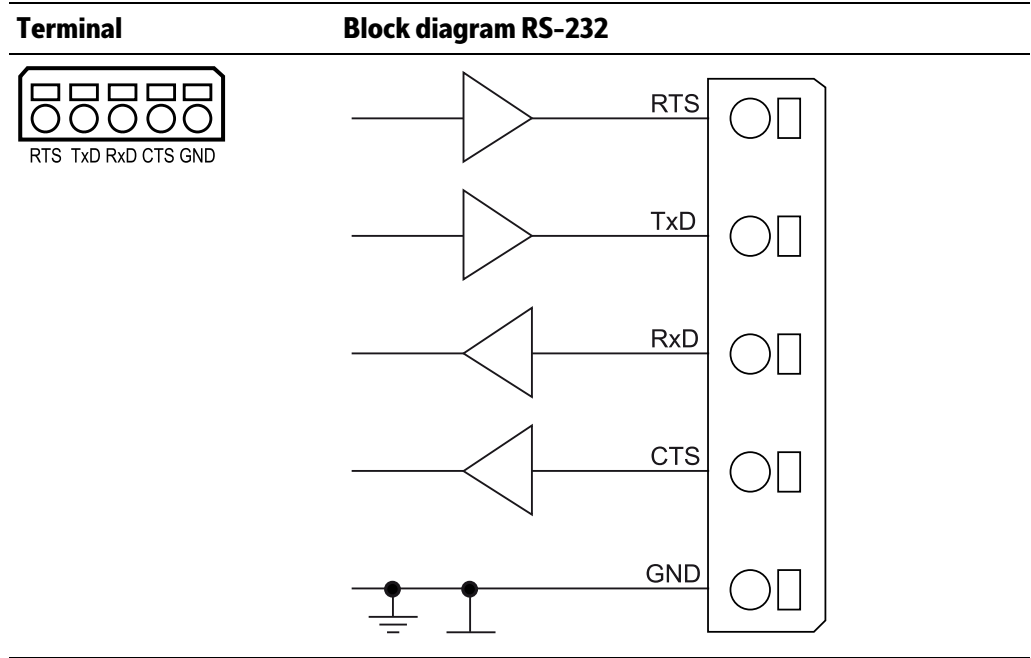

4.4.6.1 Connecting a YDP14IS ticket printer via RS-232

The YDP14IS-OCEUV ticket printer can be connected via the internal RS-232 interface.

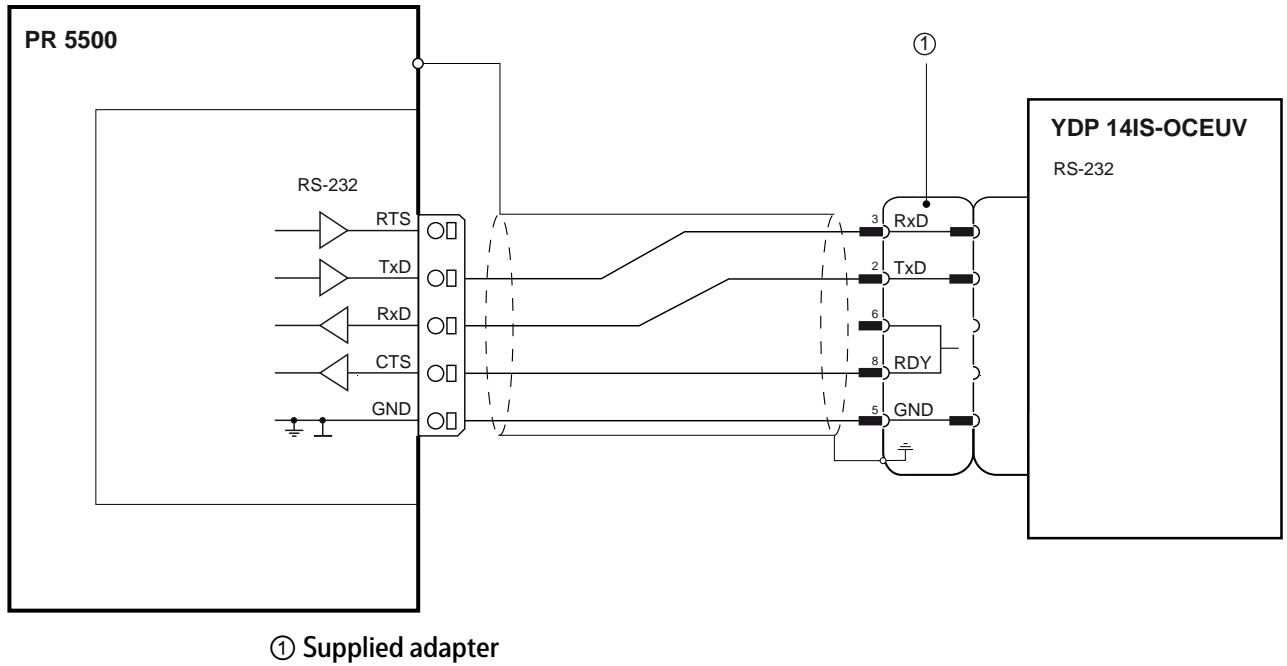

Configuration PR 5500	Printer configuration
<p>[Operating] - [System setup] - [Connected devices] - [Printer] - [Interface] - [Built-in RS-232]:</p> <ul style="list-style-type: none"> - [Protocol] to "RTS/CTS" - [Baudrate] to "9600" - [Bits] to "8" - [Parity] to "none" - [Stop bits] to "1" - [Printer type] to [raw] 	<p>The printer must be set to "Line Mode" (the factory setting is Page Mode). Press the "FEED" key to switch from one to the other.</p> <p>The procedure can be found in the printer operating instructions.</p>

4.4.6.2 Connecting additional printers

The following serial printers can also be used:

- TM-U295 from Epson
- Printer with ESC/P2 protocol

4.4.6.3 Connecting an IS platform via RS-232

One IS platform scale with xBPI or SBI protocol can be connected via the internal RS-232 interface.

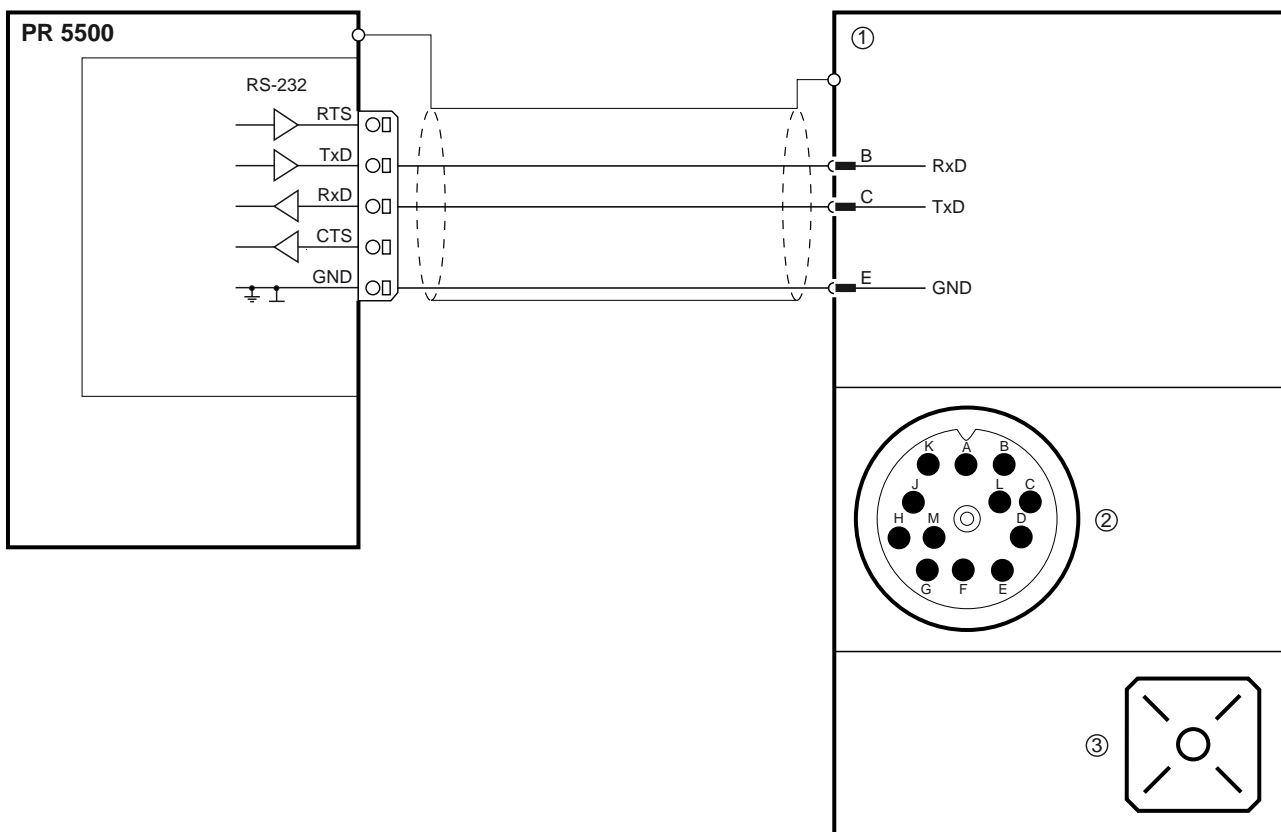

- ① IS platform xBPI protocol (slave)
- ② 12-pin male connector
- ③ AC/DC adapter

Configuration PR 5500

[Operating] - [System setup] - [Weighing points] - [Weighing point X] - [xBPI scale] - [Interface] - [Built-in RS-232]

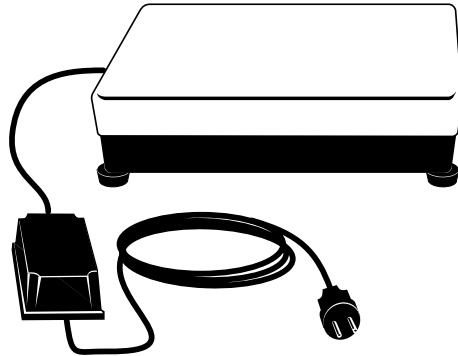

Note:

For further information, see the platform scale operating instructions.

4.4.6.4 Connecting a Mettler scale via RS-232

A Mettler scale with MT-SICS protocol can be connected via the internal RS-232 interface.
 Example: Type XS6002SDR

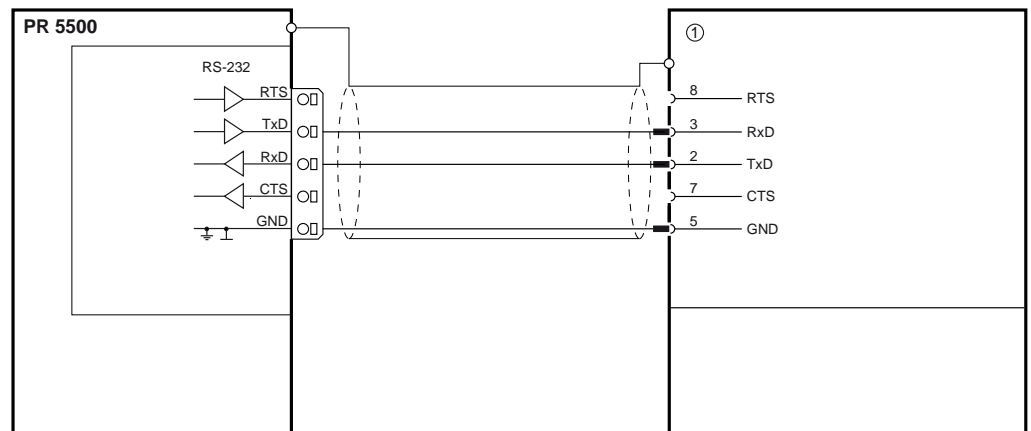

① Mettler scale type XS6002SDR MT-SCIS protocol (slave)

Configuration PR 5500

[Operating] - [System setup] - [Weighing points] - [Weighing point X] - [Mettler-Scale] - [Interface] - [Built-in RS-232]

For the parameter settings for the Mettler scale, please refer to [System setup] - [Weighing points] - [Mettler-Scale] - [Parameters] in the PR 5500 operating instructions.

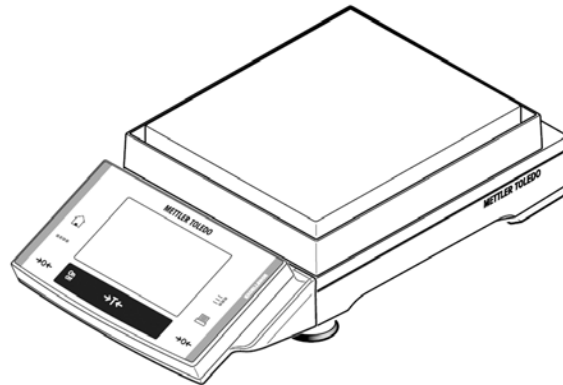

Note:

For more information, see the manual for the Mettler scale.

4.5 Accessories

4.5.1 PR 5500/04 2x RS-485 interface

The plug-in card contains two channels. One channel can be used for connecting an IS platform without an external power supply.

Note:

Either the internal weighing point or an IS platform without an external power supply may be used.

The RS-485 interface can be selected and configured in the Setup menu.

Using the RS-485 interface is compulsory with a multi-point connection (Tristate status).

The RS-485 interface can also be used as a point-to-point connection.

The card is inserted in the option 1/FB and/or option 2 slot.

A maximum of 2 PR 5500/04 cards can be installed.

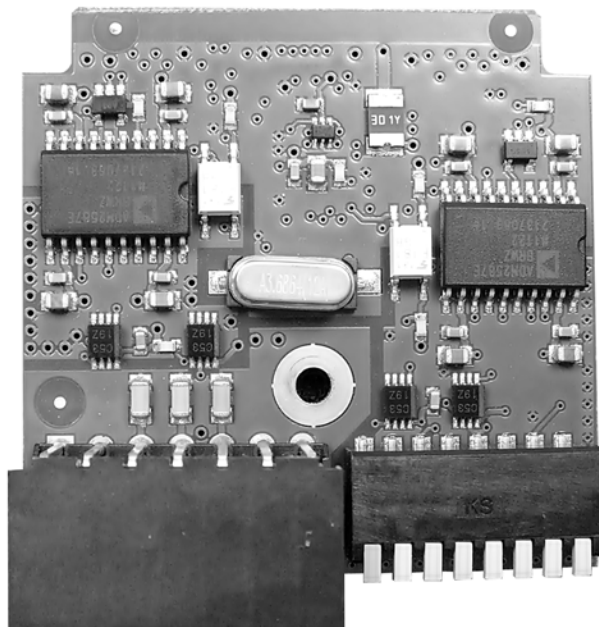

Technical data

Description	Data
Internal connection	Contact strip
External connection	2 x terminal, 7-pin
Number of channels	2
Type	RS-485, full duplex (4-wire) RS-485, half duplex (2-wire)
For external power supply	U= 24 V, 3 W (briefly up to 6 W)
Transfer rate	300 to 115 K2 Bit/s
Signals	TxA, RxA, TxB, RxB
Potential isolation	Yes
Cable gauge	Max. 1.5 mm ²
Cable length	Max. 1000 m
Cable type	Screened twisted pair (e.g., LifYCY 3x2x0.20), 1 pair of wires for ground (GND).
Dimensions (LxWxH)	50x45x18 mm
Weight	Approx. 35 g

PR 5500/04 2x RS-485 interface

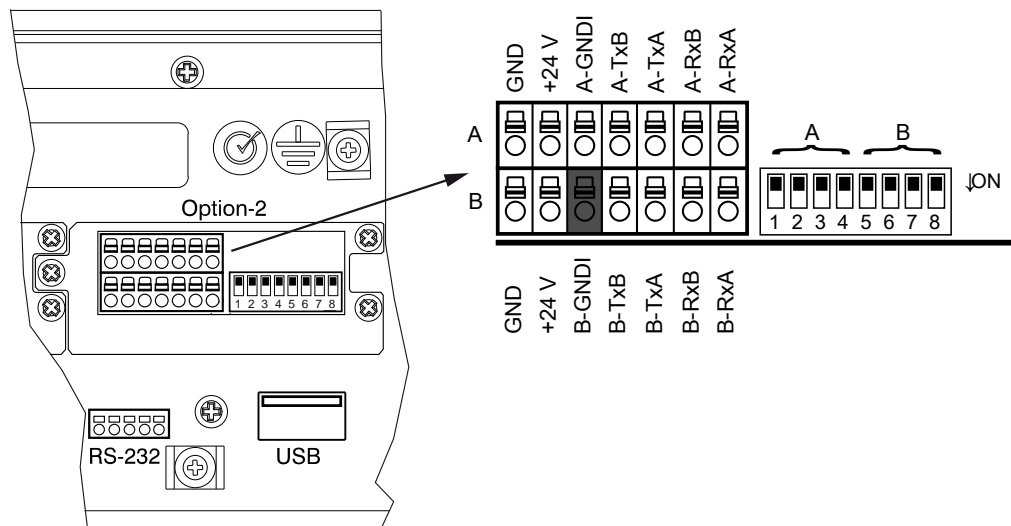
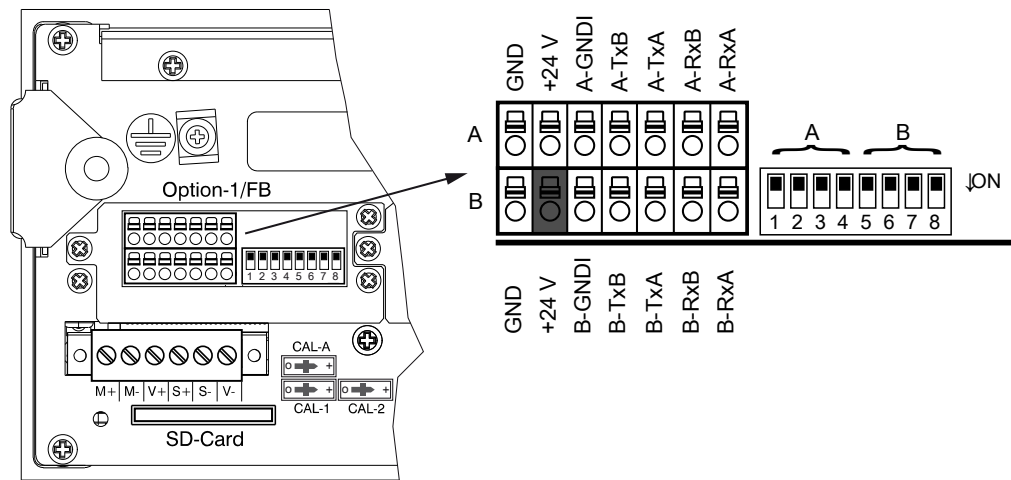

Coding for option 1 and option 2

Terminal strip: Insert the coding pin into the slot in the position marked in gray in the image.

Terminal: Remove (nip off) the relevant coding nib.

Note:

Refer to Chapter [5.2.3.3](#) for further information on terminal coding.

Block diagram 2x RS-485

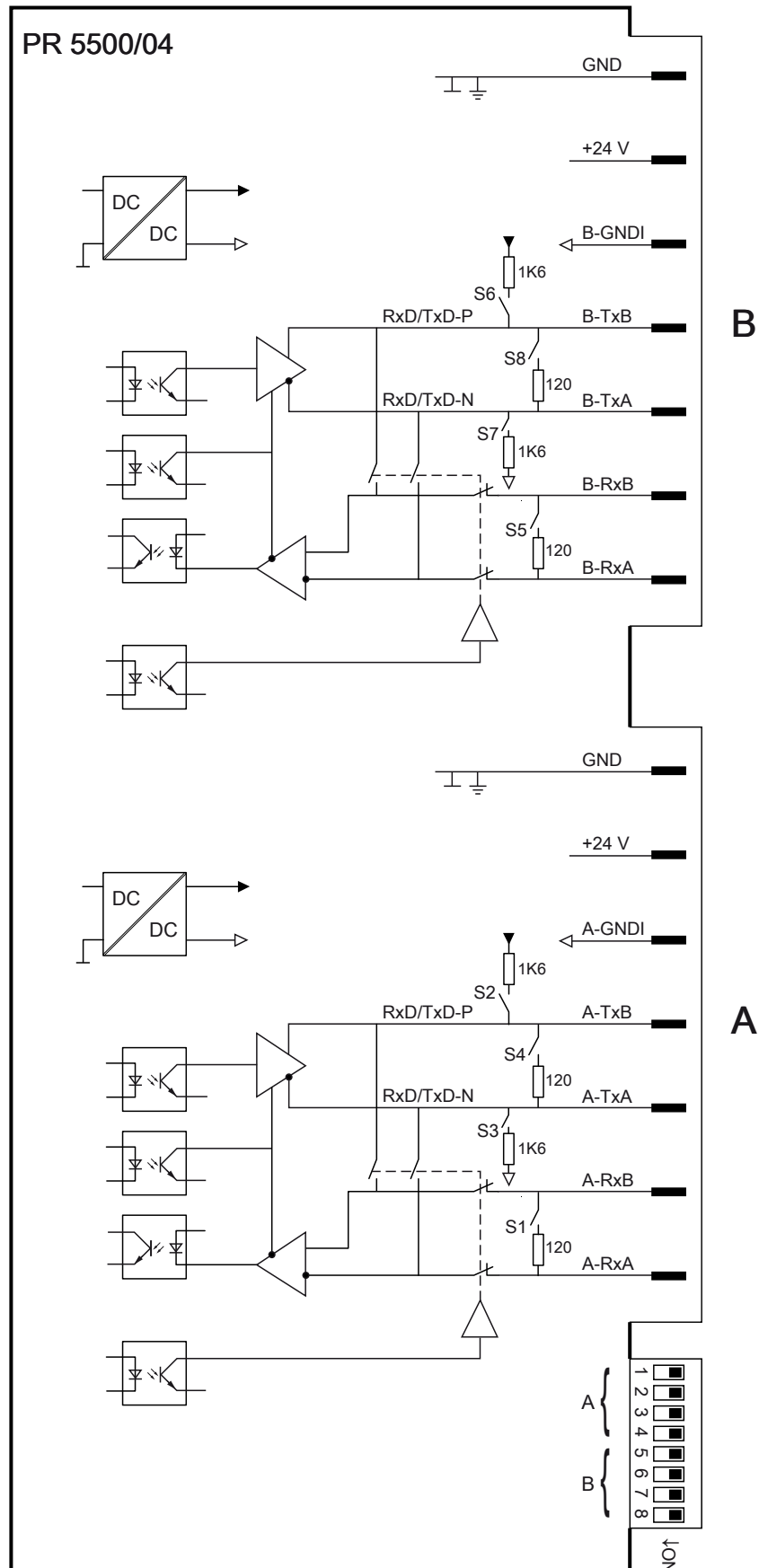

S	Function	Settings for RS-485	
1	Rx bus termination	OFF: not connected	ON: (A-RxA 120 Ω A-RxB)
2	Tx pull-up resistor	OFF: not connected	ON: (A-TxB 1K6 Ω +V)
3	Tx pull-down resistor	OFF: not connected	ON: (A-TxA 1K6 Ω -V)
4	Tx bus termination	OFF: not connected	ON: (A-TxA 120 Ω A-TxB)
5	Rx bus termination	OFF: not connected	ON: (B-RxA 120 Ω B-RxB)
6	Tx pull-up resistor	OFF: not connected	ON: (B-TxB 1K6 Ω +V)
7	Tx pull-down resistor	OFF: not connected	ON: (B-TxA 1K6 Ω -V)
8	Tx bus termination	OFF: not connected	ON: (B-TxA 120 Ω B-TxB)

4.5.1.1 Connecting peripheral devices via RS-485

- Connecting to a PC or an RS-485/RS-232 converter, 4-wire (see Chapter [4.5.1.2](#))
- Connecting to a PLC or an RS-485/RS-232 converter, 2-wire (see Chapter [4.5.1.3](#))
- Connecting multiple PR 5500 units to a PC or an RS-485/RS-232 converter (see Chapter [4.5.1.4](#))
- Connecting an IS platform via RS-485, 2-wire (see Chapter [4.5.1.5](#))
- Connecting digital load cells from type Pendeo® via RS-485 (see Chapter [4.5.1.6](#))

4.5.1.2 Connecting to a PC or an RS-485/RS-232 converter

Point-to-point connection for the EW-Com protocol (4-wire)

Example:

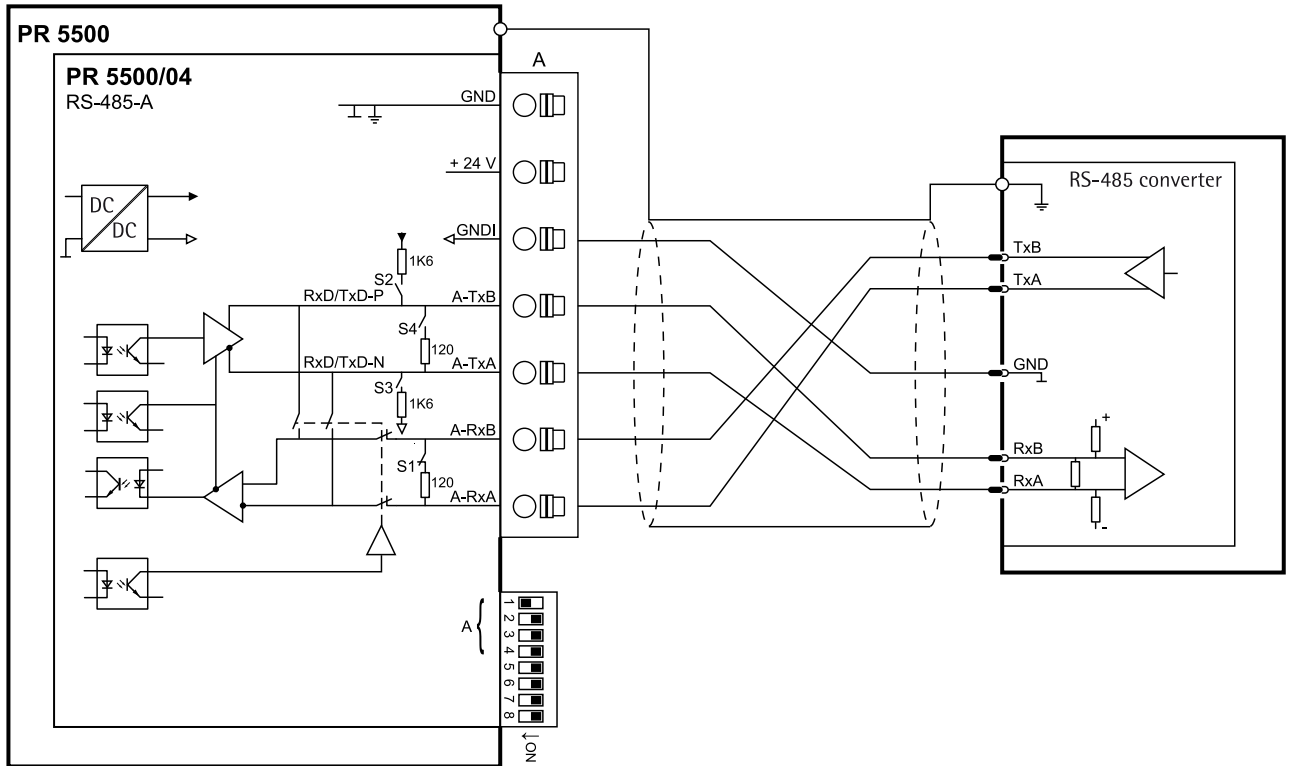

Switch settings	Configuration
ON: S1	[Operating] - [System setup] - [Connected devices] - [PC via EW-Com] - [Interface] - [Option 1 RS-485-A]
OFF: S2...S4	

4.5.1.3 Connecting to a PLC or an RS-485/RS-232 converter

Point-to-point connection for the ModBus protocol (2-wire)

Example:

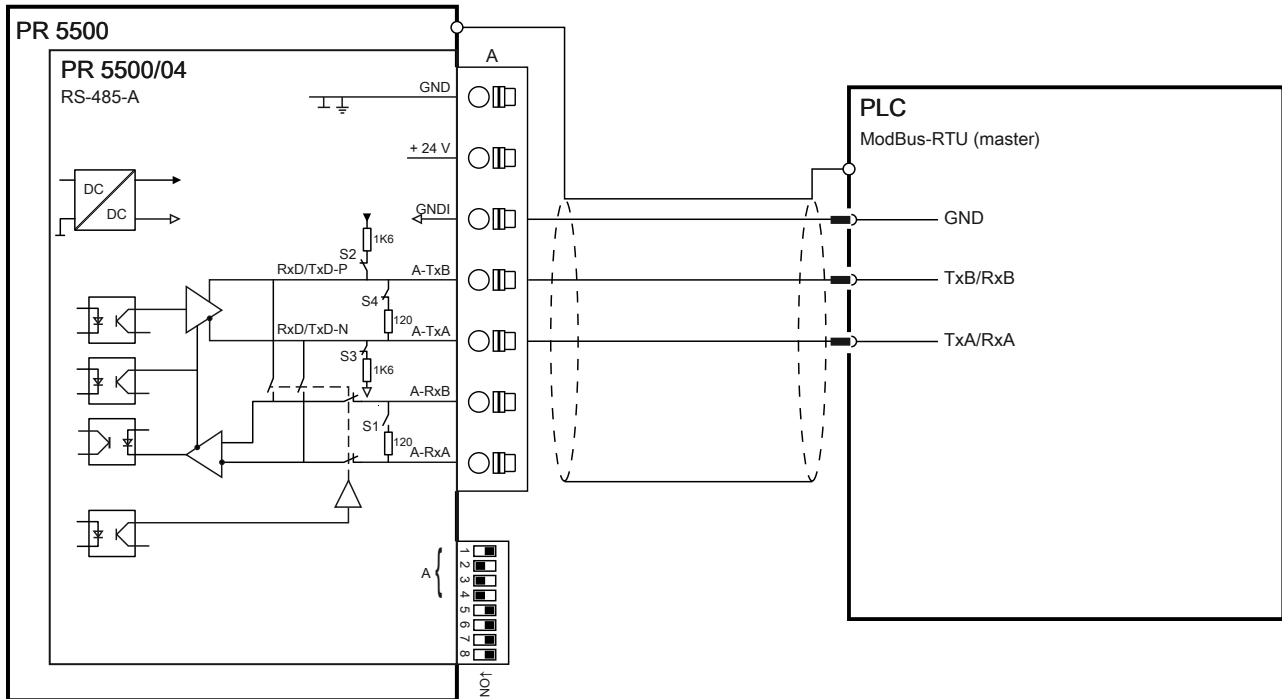

Switch settings	Configuration
ON: S2, S3, S4	[Operating] - [System setup] - [Connected devices] - [ModBus-RTU master] -
OFF: S1	[Interface] - [Option 1 RS-485-A]

4.5.1.4 Connecting multiple PR 5500 units to a PC or to an RS-485/RS-232 Converter

Connection for the EW-Com protocol.

Example:

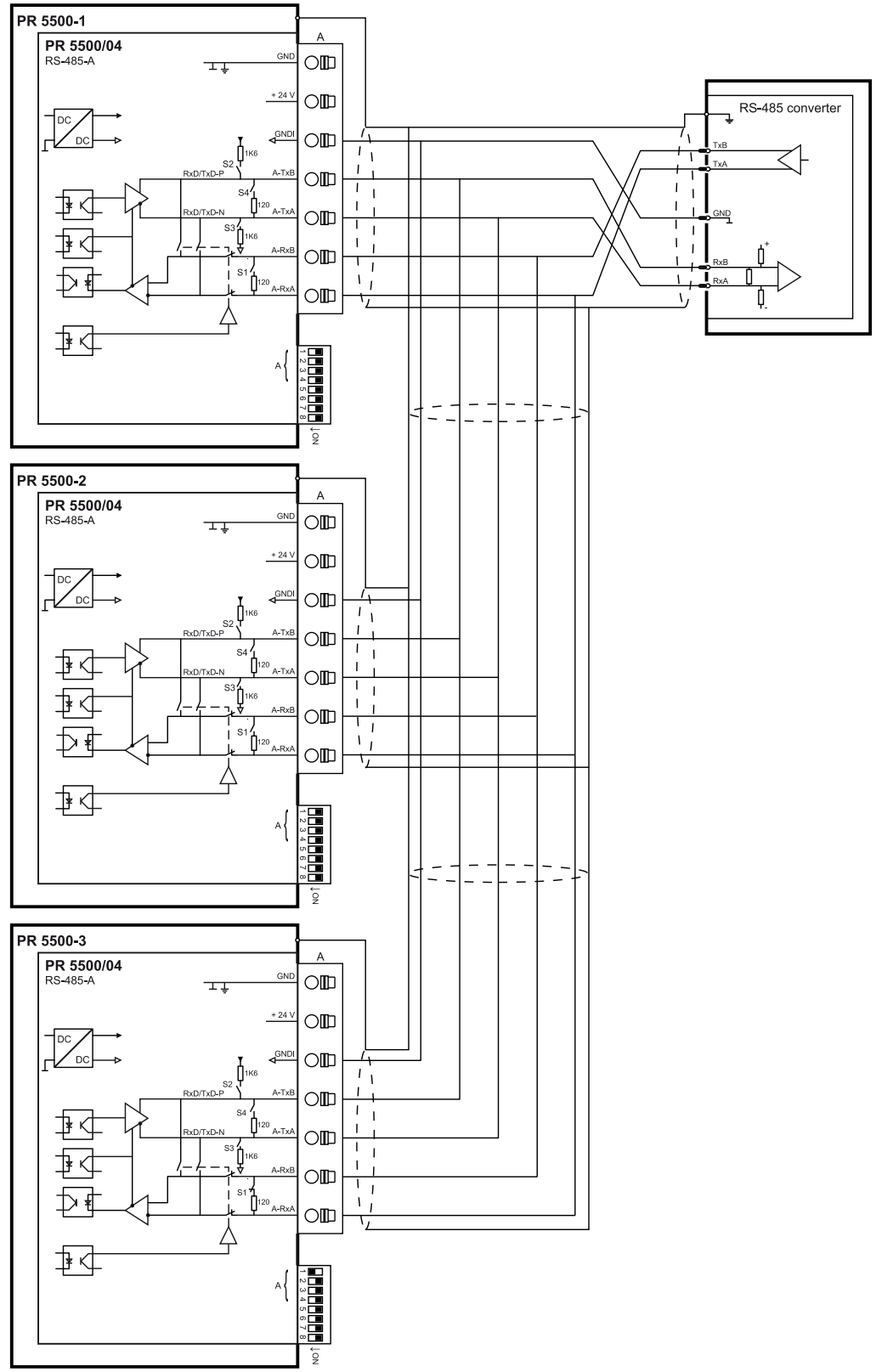

Switch setting PR 5500-1	Switch setting PR 5500-2	Switch setting PR 5500-3	Configuration
ON: - OFF: S1...S8	ON: - OFF: S1...S8	ON: S1 OFF: S2...S8	[Operating] - [System setup] - [Connected devices] - [PC via EW-Com] - [Interface] - [Option 1 RS-485-A]

4.5.1.5 Connecting an IS platform via RS-485 (2-wire)

Using this optional card, it is possible to connect an IS platform with xBPI or SBI protocol.

Note:

Only one platform can be supplied power from the PR 5500 and the weighing electronics board PR 5500/10 must not be plugged in.

Example:

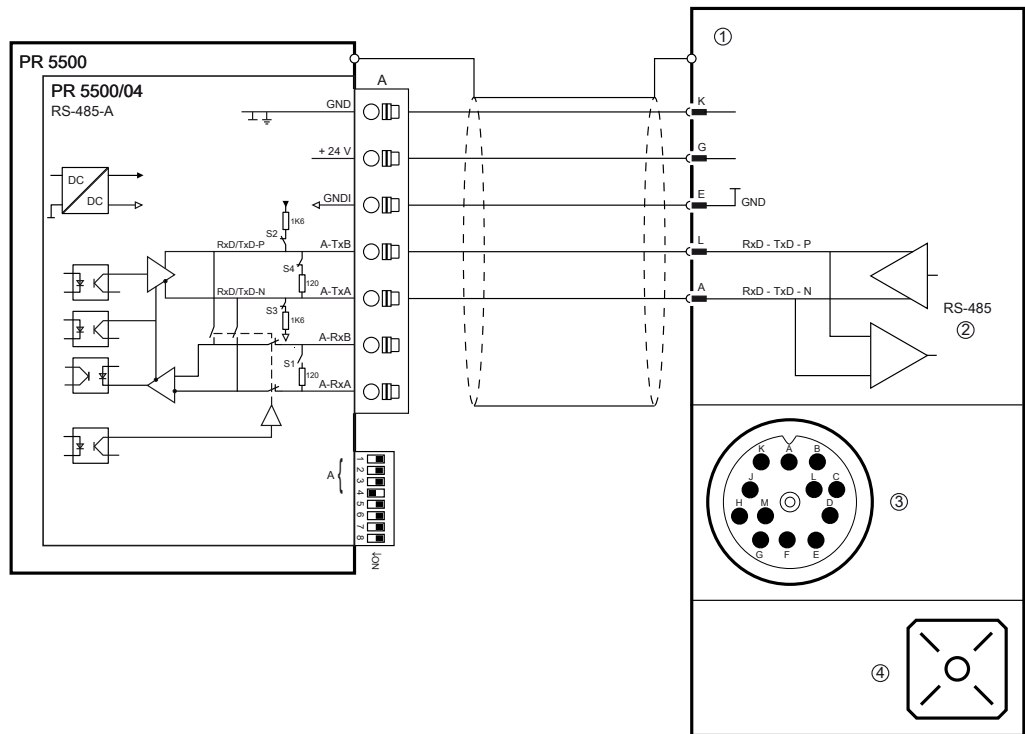

- ① IS platform xBPI protocol (slave)
- ② Half duplex
- ③ 12-pin male connector
- ④ AC/DC adapter

Switch settings PR 5500	Configuration PR 5500
ON: S2, S3, S4 OFF: S1	[Operating] - [System setup] - [Weighing points] - [Weighing point X] - [xBPI scale] - [Interface] - [Option x RS-485-A]

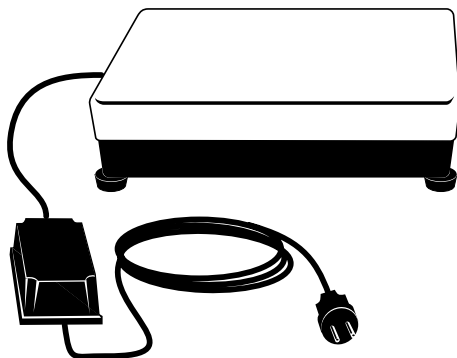
**Note:**

For further information, see the platform scale operating instructions.

4.5.1.6 Connecting digital load cells from type Pendeo®

The device can be ported to Pendeo® type digital load cells via the xBPI port and the RS-485 interface (2-wire).

Connections

Color code	Color	Terminal designation	Description
rd	red	+	+ Supply voltage
bu	blue	-	- Supply voltage
gr	green	B	B Signal
gy	gray	A	A Signal

The following example shows the connection to the PR 6024/68S junction box using 8 digital load cells, type Pendeo®.

Connection example

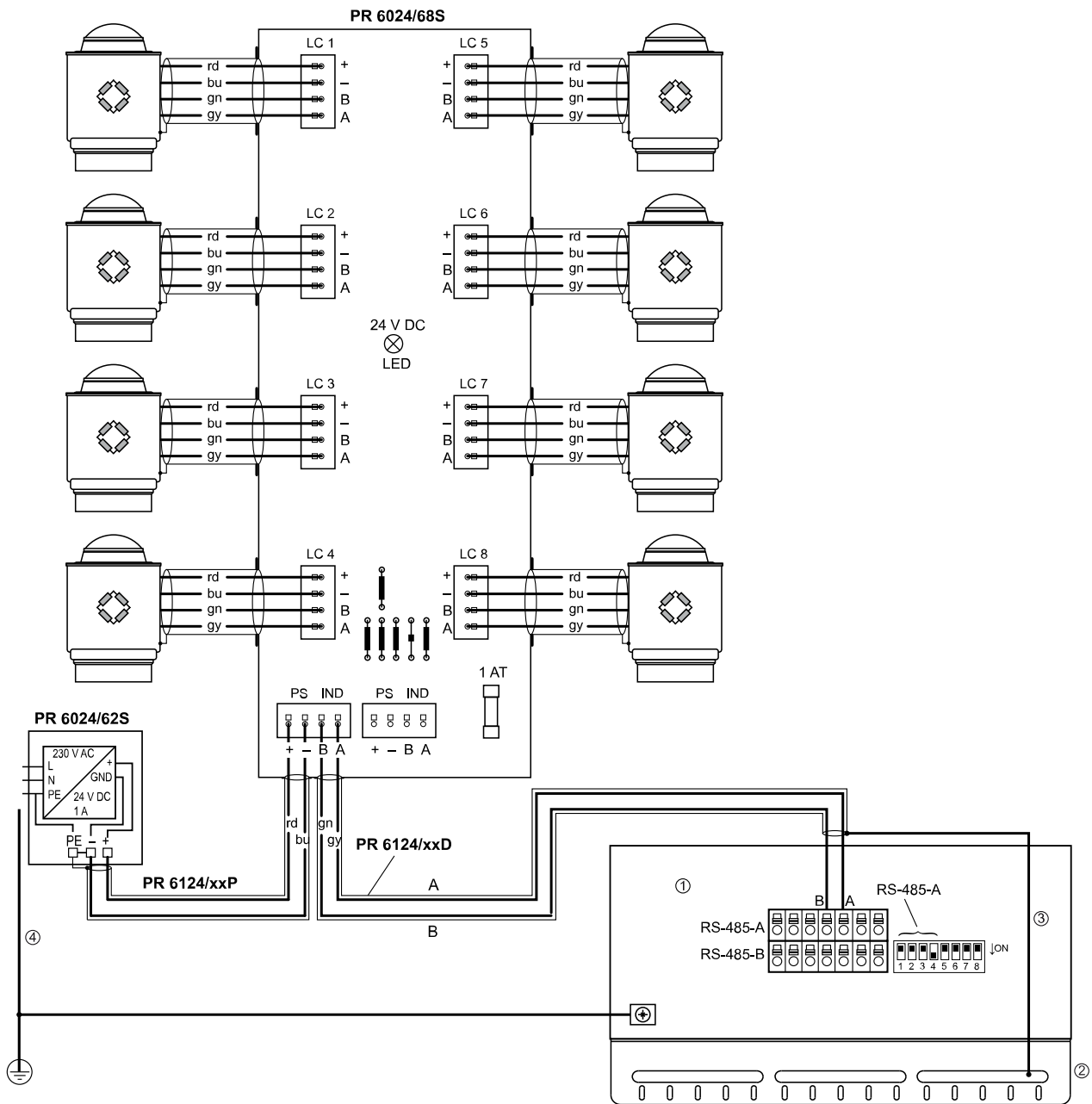

- ① PR 5500 with PR 5500/04
- ② Grounding terminal or screen clamping rail
- ③ Screen
- ④ Equipotential bonding conductor

Note:

For further information, see the installation manuals relating to the load cells and junction boxes.

4.5.2 PR 5500/32 2x RS-232 interface

The plug-in card contains two channels. One channel can be used for connecting an IS platform without an external power supply. The jumper (1) must then be set to A-24 V or B-24 V.

When an IS platform is connected without an external power supply, no analog weighing electronics unit may be installed in the device and no load cells may be connected.

The RS-232 interface can be selected and configured in the Setup menu.

The card is inserted in the option 1/FB and/or option 2 slot.

A maximum of 2 PR 5500/32 cards can be installed.

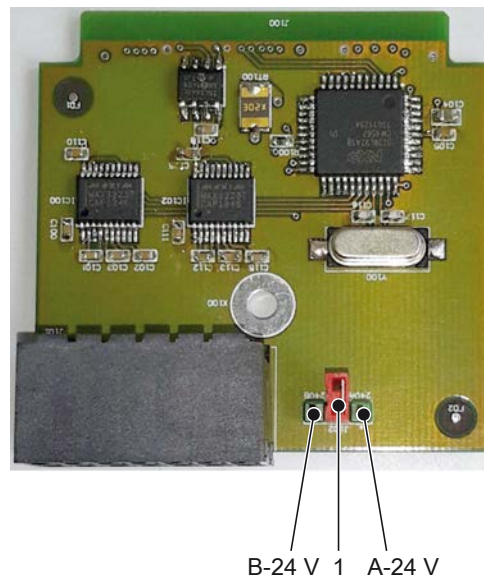

Technical data

Description	Data
Internal connection	Contact strip
External connection	2× terminal, 7-pin
Number of channels	2
Type	RS-232, full duplex
Transfer rate	300 to 115 K2 Bit/s
Parity	None, odd, even
Data bits	7/8 bit
Input signal level	Logic 1 (high) -3 to -15 V Logic 0 (low) +3 to +15 V
Output signal level	Logic 1 (high) -5 V to -15 V Logic 0 (low) +5 V to +15 V
Number of signals	Input: RxD, CTS Output: TxD, RTS
Potential isolation	None

Description	Data
Cable gauge	Max. 1.5 mm ²
Cable length	Max. 15 m
Cable type	Screened twisted pair (e.g., LifYCY 3x2x0.20), 1 pair of wires for ground (GND).
Power supply for IS platform	can be switched to channel A or B
Dimensions (LxWxH)	50x45x18 mm
Weight	Approx. 35 g

PR 5500/32 2x RS-232 interface

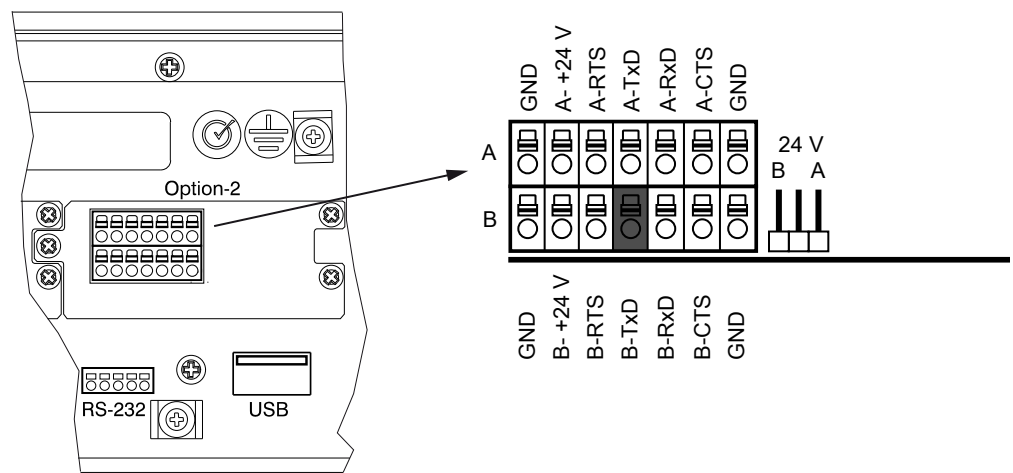
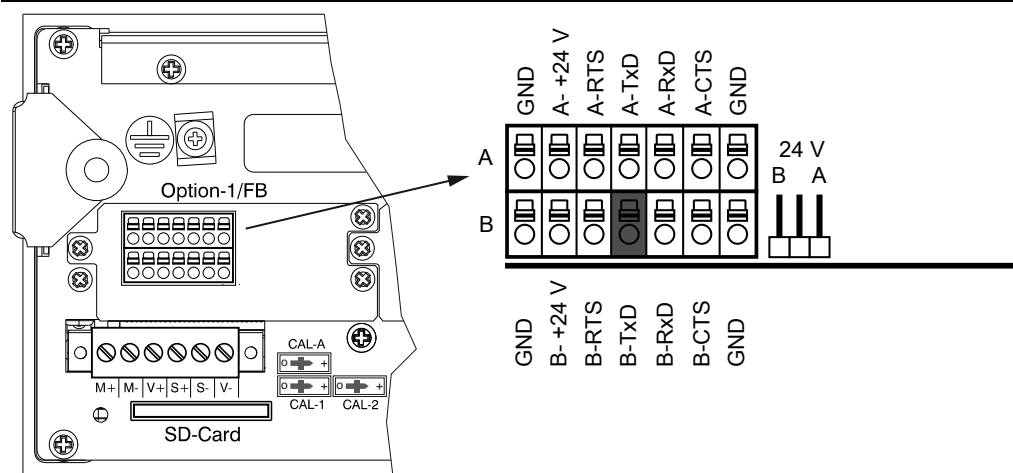

Coding for option 1 and option 2

- Terminal strip:** Insert the coding pin into the slot in the position marked in gray in the image.
- Terminal:** Remove (nip off) the relevant coding nib.

Note:

Refer to Chapter [5.2.3.3](#) for further information on terminal coding.

Block diagram 2x RS-232

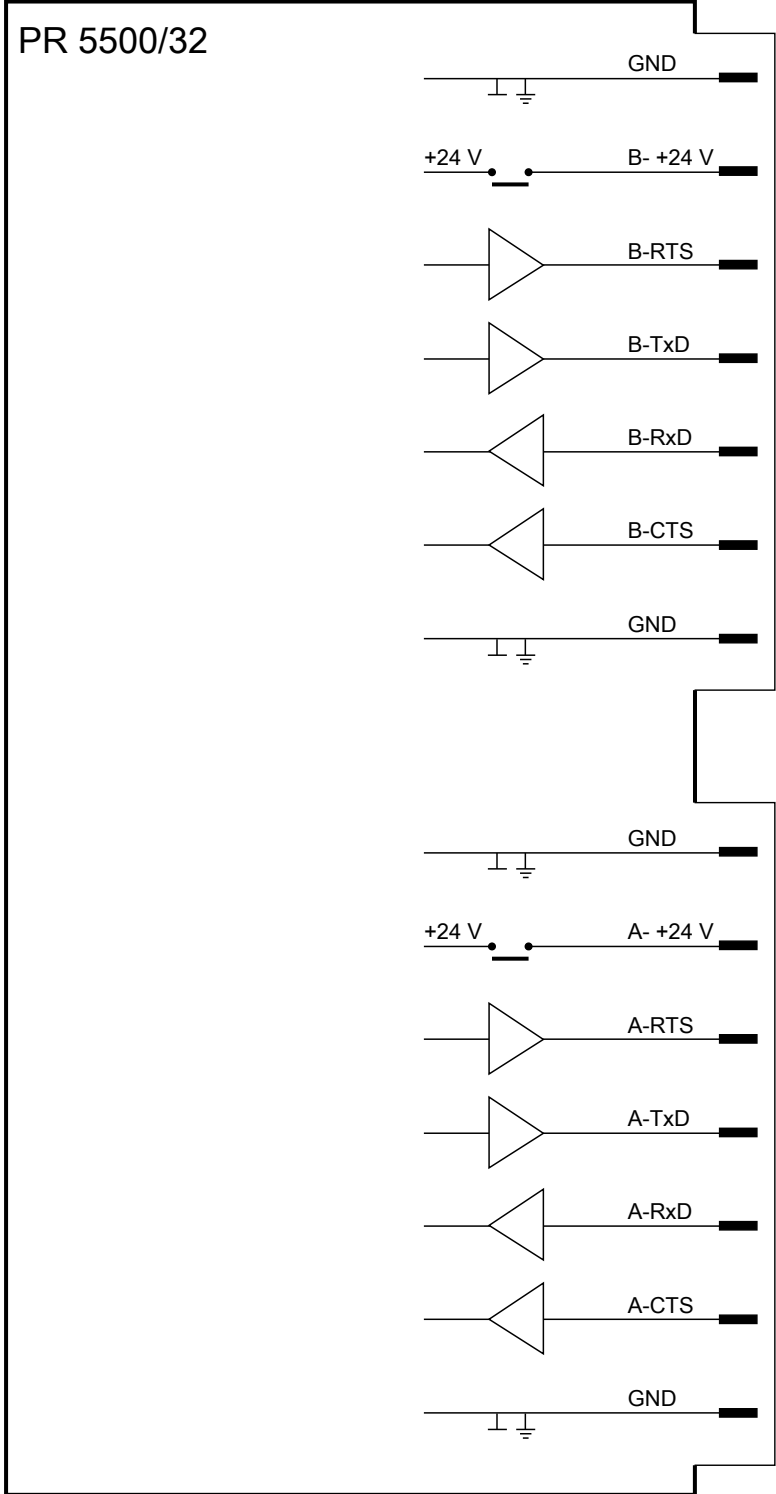

4.5.2.1 Connecting peripheral devices via RS-232

- Connecting a YDP14IS ticket printer via RS-232 (see Chapter 4.4.6.1)
- Connecting a Mettler scale via RS-232 (see Chapter 4.4.6.4)

4.5.2.2 Connecting an IS platform via RS-232

Using this optional card, it is possible to connect an IS platform with xBPI or SBI protocol.

Note:

Example:

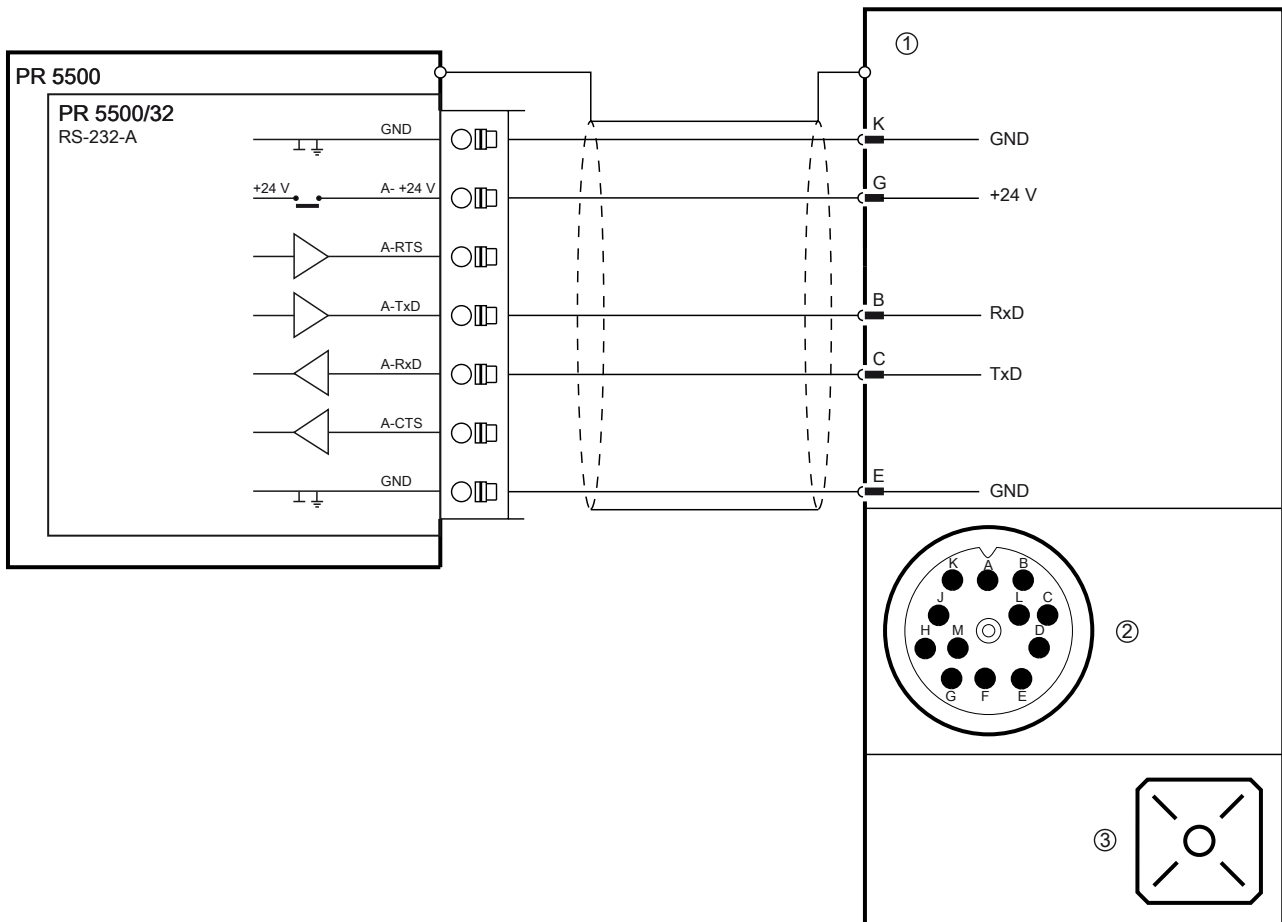

- ① IS platform xBPI protocol (slave)
- ② 12-pin male connector
- ③ AC/DC adapter

Jumper position	Configuration
Channel A A- +24 V	[Operating] - [System setup] - [Weighing points] - [Weighing point X] - [Interface] - [xBPI scale] - [Option x RS-232-A]

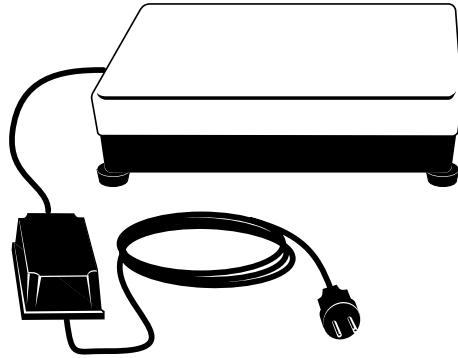
**Note:**

For further information, see the platform scale operating instructions.

4.5.3 PR 5500/07 analog input and output

The plug-in card for the available analog channels has 1 analog output (active) and 1 analog input.

The card is inserted in the option 1/FB and/or option 2 slot.

A maximum of 2 PR 5500/07 cards can be installed.

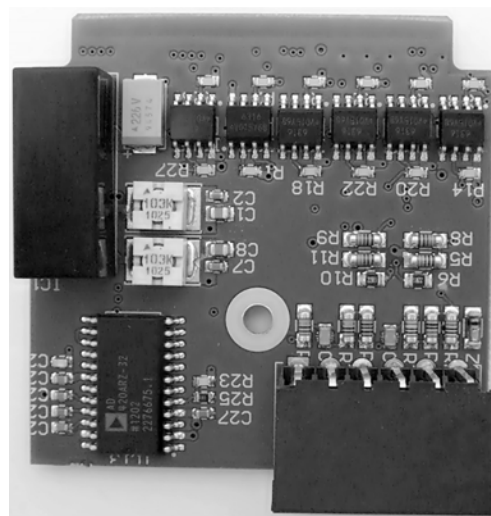

Description	Data
Output temperature error	<100 ppm/K
Output zero point error	0.05%
Output max. error	<0.1%
Load	Max. 0 to 500 Ω
Potential isolation	Yes
Cables	<150 m, screened
Input	
Input	1 current or voltage input
Input range	0 to 10 V or 0 to 20 mA
Input resistance	100 k Ω for 10 V measurement input 200 Ω for 20 mA measurement input
Input resolution	Internal 14 bits binary = 20,000 counts, @ e.g. 0 to 20 mA/0 to 10 V
Input max. error	0.2%
Input linearity error	<0.02%
Input temperature error	<75 ppm/K
Input thresholds	$\pm 15\%$, i.e., -1.5 V to +11.5 V
Potential isolation	Yes, joint inputs and outputs
Cables	<150 m, screened
Connection	
Internal connection	Contact strip
External connection	2 x terminal, 6-pin
Dimensions (LxWxH)	50x45x18mm
Weight	Approx. 40 g

PR 5500/07 2x interface

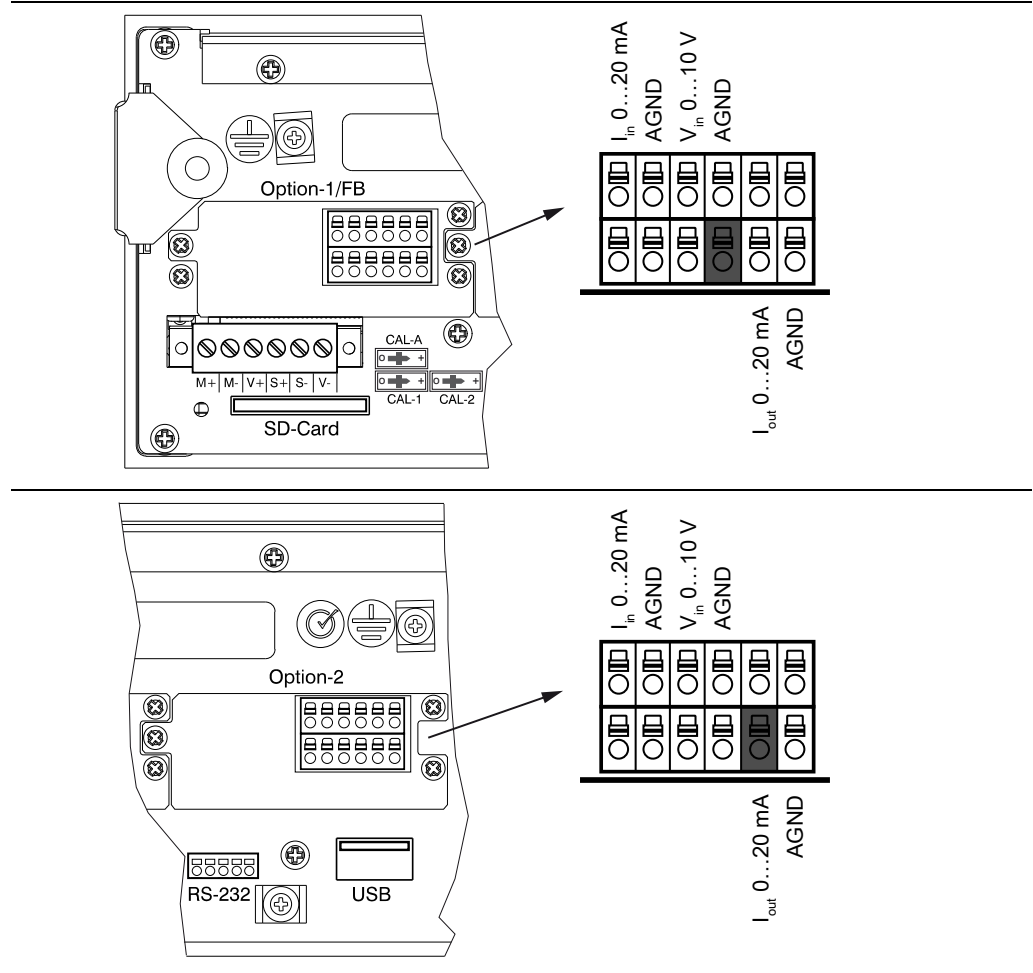

Coding for option 1 and option 2

Terminal strip: Insert the coding pin into the slot in the position marked in gray in the image.

Terminal: Remove (nip off) the relevant coding nib.

Note:

Refer to Chapter [5.2.3.3](#) for further information on terminal coding.

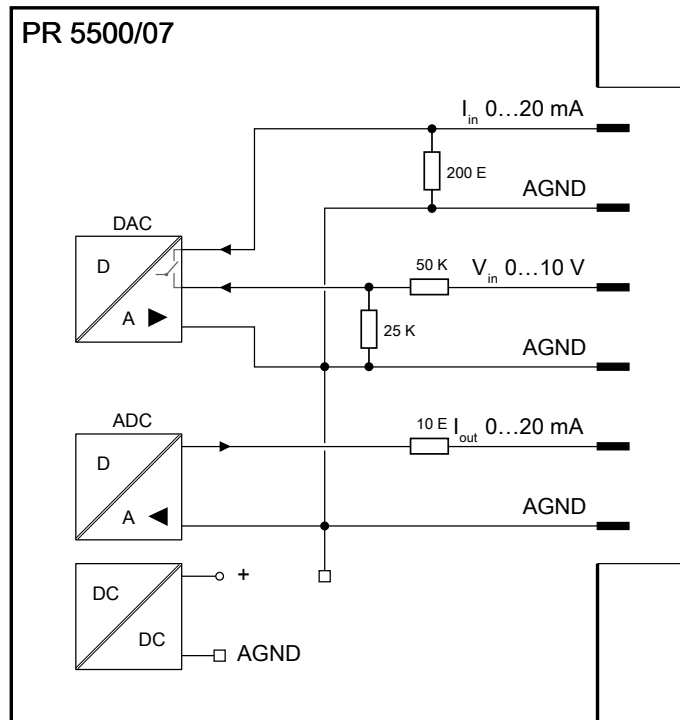

4.5.4 PR 5500/10 weighing electronics board

The weighing electronics board is inserted in the WP A slot.

The CAL switch A (1) is located on the board.

Calibration data and parameters are saved to the EARAM (non-volatile memory) of the weighing electronics board.

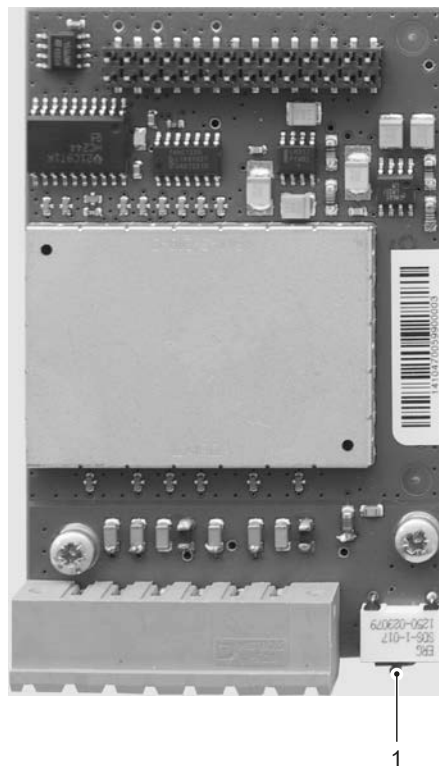

Technical data

Description	Data
Internal connection	Pin strip, 28-pin
External connection	6-pin male connector, Screen connection on housing
Load cell supply	$U_{DC} = 12\text{ V}$, symmetrical to zero ($U_{DC} = \pm 6\text{ V}$, $I_{max} = 160\text{ mA}$)
Capacity (number of load cells)	$\geq 75\ \Omega$, corresponding to 8 load cells with $650\ \Omega$ or 4 load cells with $350\ \Omega$
Sense input	$U_{DC} = \pm 6\text{ V}$, with monitoring
Measurement input	$U_{DC} = 0\text{...}36\text{ mV}$, symmetrical to 0
Dead load suppression	$U_{DC} = \text{max. } 36\text{ mV}$ (dead load + range)
Accuracy	Complies with OIML R76 class III
Min. measuring signal (OIML)	10,000 d: 0.2 mV/V with 12 V supply [$0.24\ \mu\text{V/d}$]
Max. resolution	7.5 million counts internally
Linearity	$< 0.003\%$
Temperature coeff. Zero (T_{k0})	$< 0.05\ \mu\text{V/K RTI}$, $< 0.004\%/10\text{K}$ @ 1 mV/V
Temperature coeff. Vst (T_{kspan})	$< \pm 4.0\text{ ppm/K}$
Cable length	Max. 300 m with PR 6135
Cable type	6-wire with screen for entire cable and screen for measurement cables, e.g., PR 6135/..
Dimensions (LxWxH)	85x50x25 mm
Weight	Approx. 60 g

4.5.4.1 Analog connections

The connection for analog load cells or analog platforms (e.g. CAPP series) is located on the housing rear panel. The supply voltage is protected against short circuit and overload.

Note:

Do not shorten the load cell cable. Connect the prepared cable end and roll up the remaining cable.

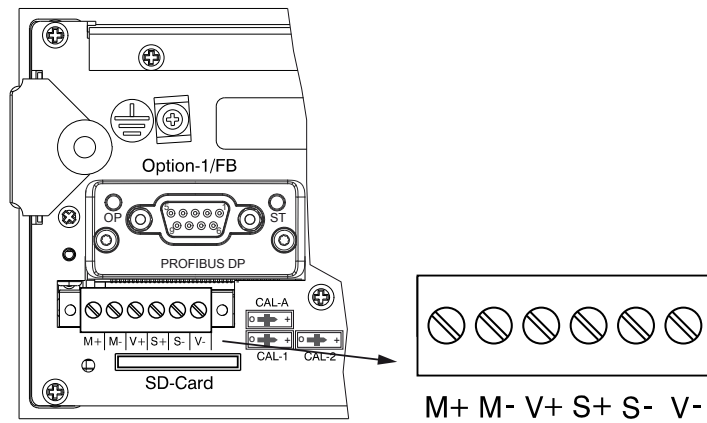

Terminal	Connection	Description
M+	+ Meas.	+ Signal/LC output
M-	- Meas.	- Signal/LC output
V+	+ Supply	+ Supply/excitation
S+	+ Sense	+ Sense
S-	- Sense	- Sense
V-	- Supply	- Supply/excitation

4.5.4.2 Connecting a load cell with a 4-wire cable

Note:

The colors listed here apply for the Minebea Intec load cell and connection cables of type "PR ..."

Color code

bk	=	Black
bu	=	Blue
gn	=	Green
gy	=	Gray
rd	=	Red
wh	=	White

For additional information on the connection of load cells and cable junction boxes, refer to the corresponding installation manuals.

The following links between the terminal contacts are provided:

- ① from + Supply (+V) to + Sense (+S)
- ② from - Supply (-V) to - Sense (-S)

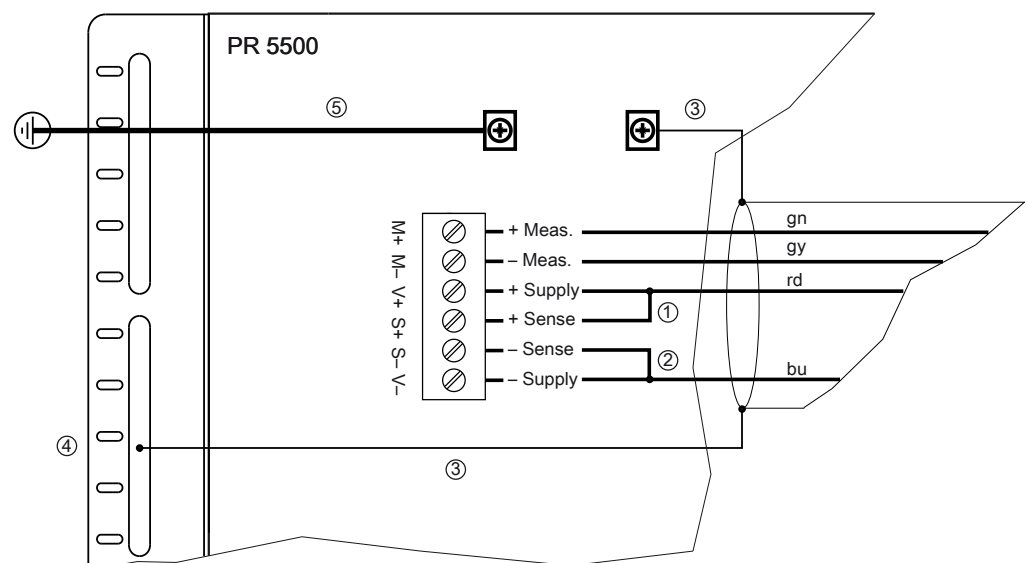

- ③ Screen
- ④ Grounding terminal or screen clamping rail
- ⑤ Equipotential bonding conductor

4.5.4.3 Connecting a load cell with a 6-wire cable

Note:

The colors listed here apply for the Minebea Intec load cell and connection cables of type "PR ..."

Color code

bk	=	Black
bu	=	Blue
gn	=	Green
gy	=	Gray
rd	=	Red
wh	=	White

For additional information on the connection of load cells and cable junction boxes, refer to the corresponding installation manuals.

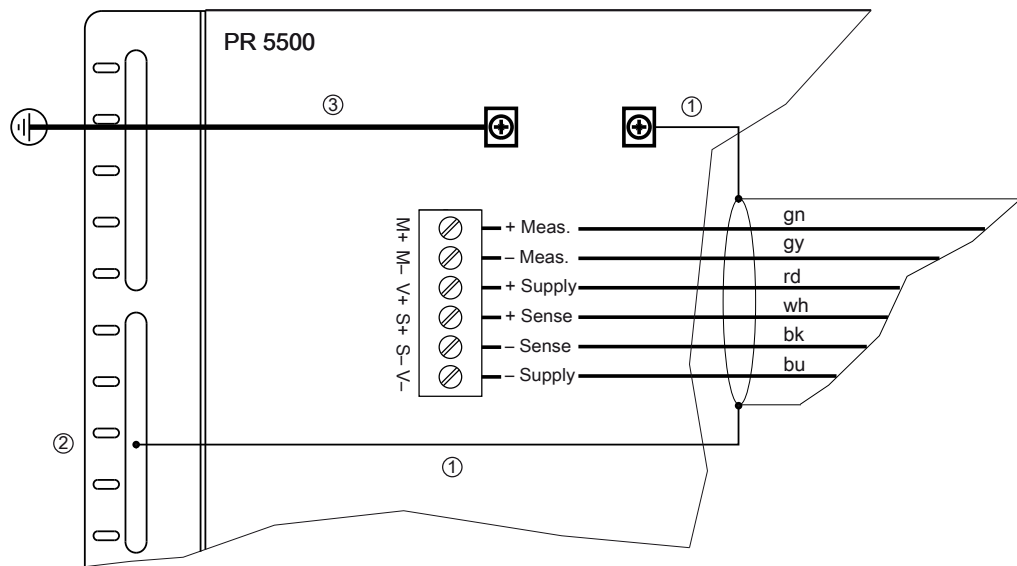

- ① Screen
- ② Grounding terminal or screen clamping rail
- ③ Equipotential bonding conductor

4.5.4.4 Connecting up to 8 load cells (650 Ω) using a 6-wire connection cable

Connections are made via cable junction box PR 6130/.. using connection cable PR 6135/.. or PR 6136/... .

Note:

The colors listed here apply for the Minebea Intec load cell and connection cables of type "PR ..."

Color code

bk	=	Black
bu	=	Blue
gn	=	Green
gy	=	Gray
rd	=	Red
wh	=	White

For additional information on the connection of load cells and cable junction boxes, refer to the corresponding installation manuals.

Recommendation

- Install cable in steel pipe connected to a ground potential.
- The distance between the measuring cables and the power cables should be at least 1 m.

Load cell supply circuit

- Load resistance of load cell circuit $\geq 75 \Omega$, e.g., 8 load cells of 650 Ω each
- The supply voltage is fixed at $U_{DC} = 12 \text{ V}$ and protected against short circuits.

For further technical data, see Chapter [7.3](#)

Note:

If hum interference occurs, the cable screens should only be connected on one side.

Depending on the design of the cable junction box used, either the jumper J3 must be removed or the cable screens must be disconnected from the terminal contacts highlighted in yellow.

Connection example

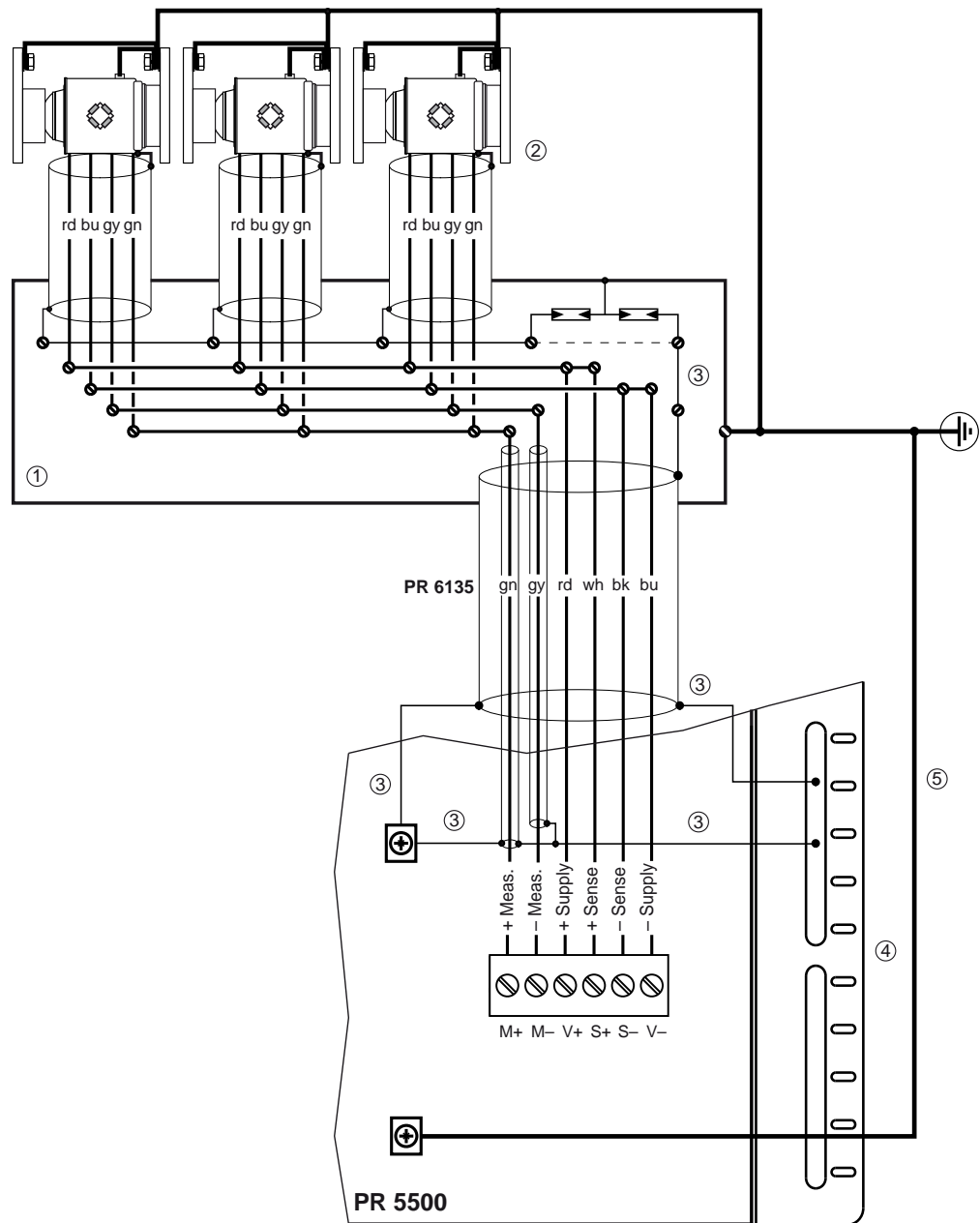

- ① Cable junction box
- ② The cable screen is connected to the load cell housing.
- ③ Screen
- ④ Grounding terminal or screen clamping rail
- ⑤ Equipotential bonding conductor

4.5.4.5 Testing the measuring circuit

A simple test with the load cells connected can be carried out with a multimeter.

Note:

In the case of an external load cell supply voltage or use of an isolating unit, the internal load cell supply is not relevant.

Measuring voltage

0–12 mV = @ LC with 1.0 mV/V
 0–24 mV = @ LC with 2.0 mV/V

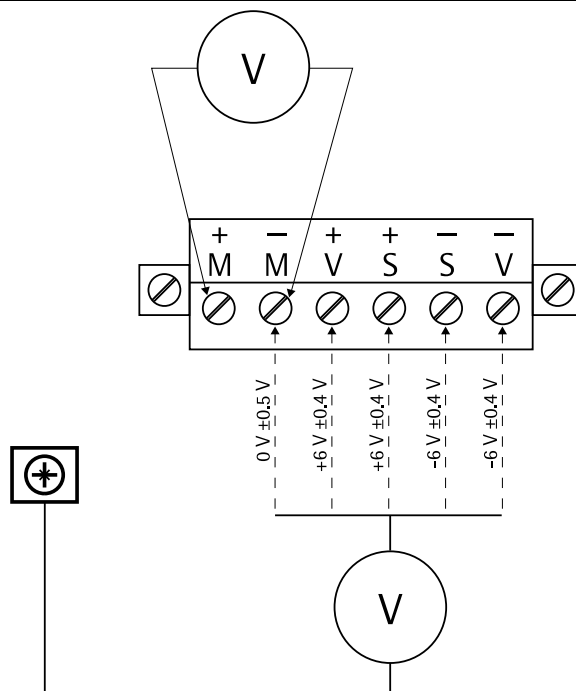

4.5.4.6 Connecting load cells to an external supply

If the total resistance of the load cells is $\leq 75 \Omega$ (e.g., more than 4 load cells with 350Ω), an external load cell supply is required. In this case, the internal supply is replaced by a potential-free external supply.

The center of the external supply voltage (0 ext. supply) should be connected to the device housing to ensure that the voltage reacts symmetrically to 0.

The internal supply is not connected.

Note:

The colors listed here apply for the Minebea Intec load cell and connection cables of type "PR ..."

Color code

bk	=	Black
----	---	-------

bu	=	Blue
----	---	------

gn	=	Green
----	---	-------

gy	=	Gray
----	---	------

rd	=	Red
----	---	-----

wh	=	White
----	---	-------

For additional information on the connection of load cells and cable junction boxes, refer to the corresponding installation manuals.

Connection example

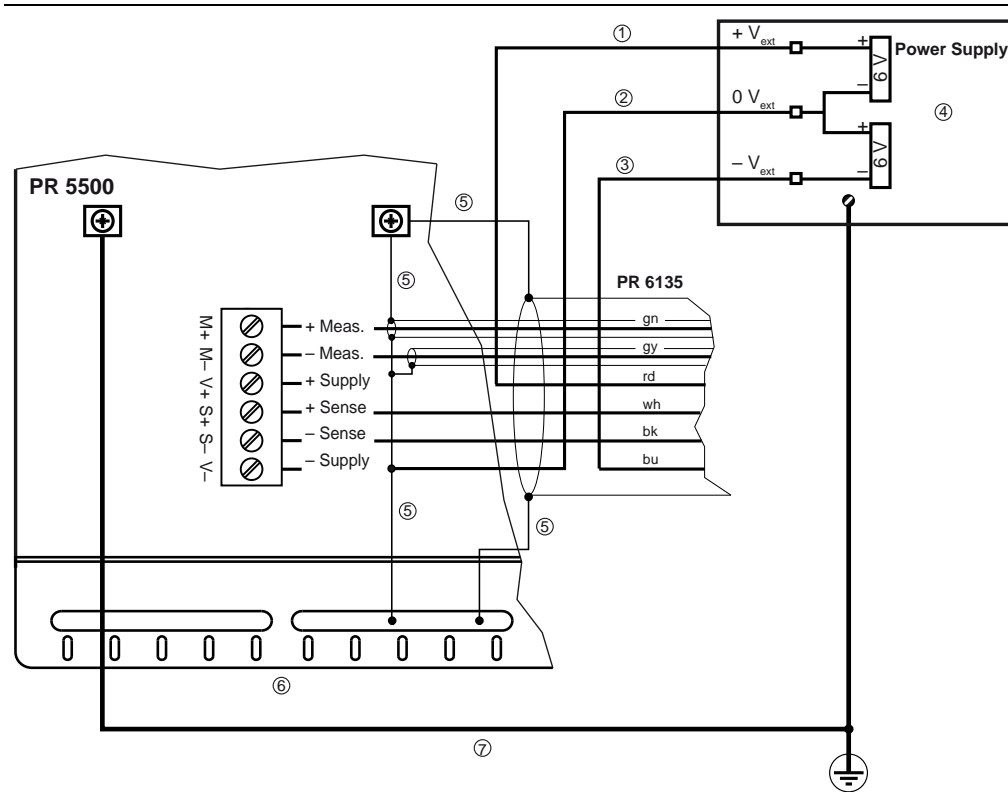

- ① + ext. supply
- ② 0 ext. supply
- ③ - ext. supply
- ④ Potential-free
- ⑤ Screen
- ⑥ Grounding terminal or screen clamping rail
- ⑦ Equipotential bonding conductor

4.5.4.7 Connecting an analog weighing platform (CAP... series)

Up to 2 Combics analog platforms (CAP... series) can be connected to the internal weighing electronics connections depending on the model.

NOTICE

The cable colors shown here are valid, for example, for a CAPP4 500 x 400 and a CAPP1 320 x 420.

- ▶ The assignments of cable colors are listed in the relevant weighing platform operating instructions.

Cable screens should be connected to the screen clamping rail of the device. If the measuring lines (+M, -M) are screened, these screens must be connected to the "GNDA" in the terminal block.

Cable screens should be connected to the grounding terminal or the screen clamping rail of the device.

Cable colors for CAPP1 and CAPP4:

Green = green

White = white

Gray = gray

Black = black

Red = red

Blue = blue

Example:

Platform with 4-wire connection

The following links should be set directly on the terminal block for platforms with a 4-wire connection:

- ① from + Supply (+V) to + Sense (+S)
- ② from - Supply (-V) to - Sense (-S)

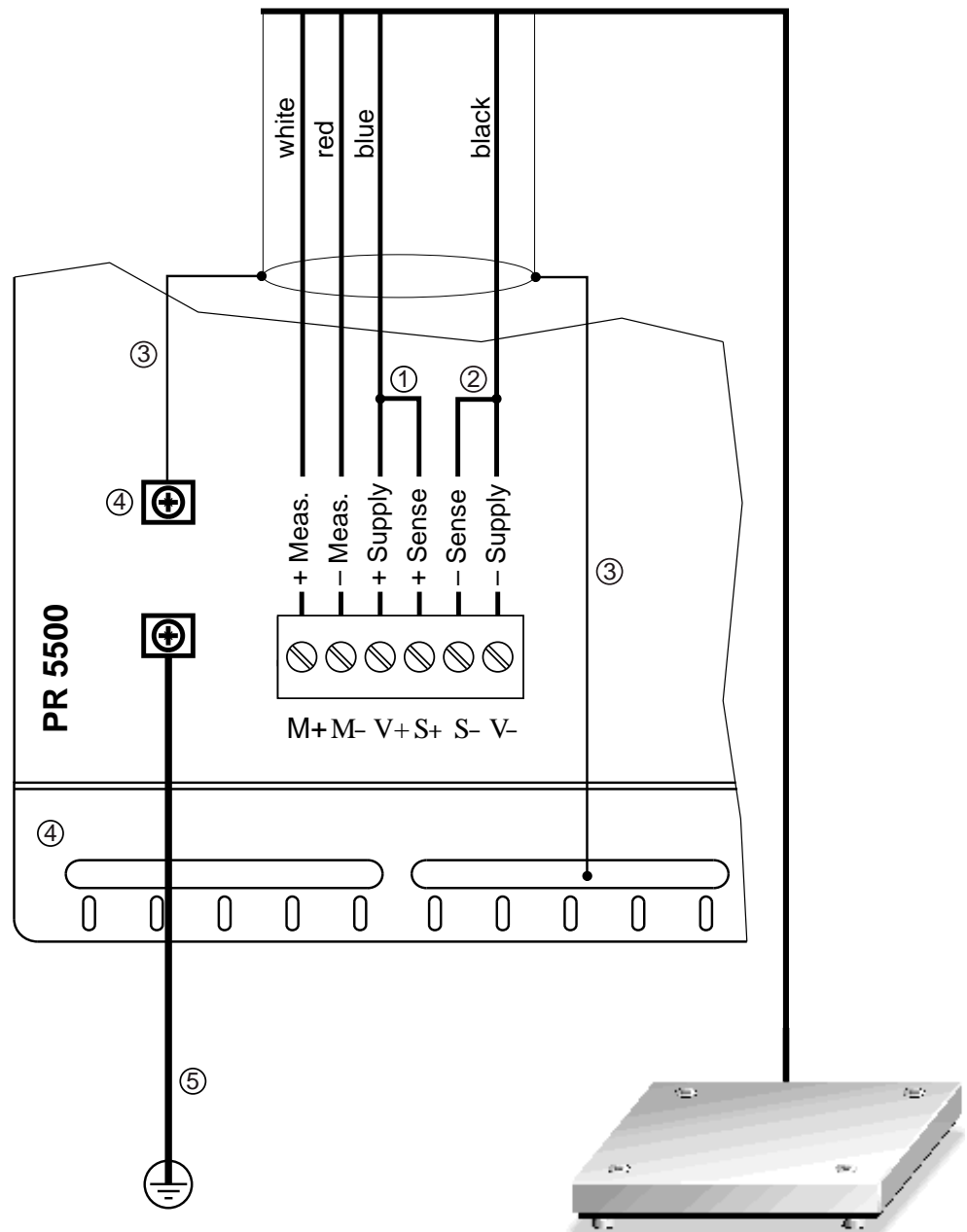

- ③ Screen
- ④ Grounding terminal or screen clamping rail
- ⑤ Equipotential bonding conductor

Example:

Platform with 6-wire connection

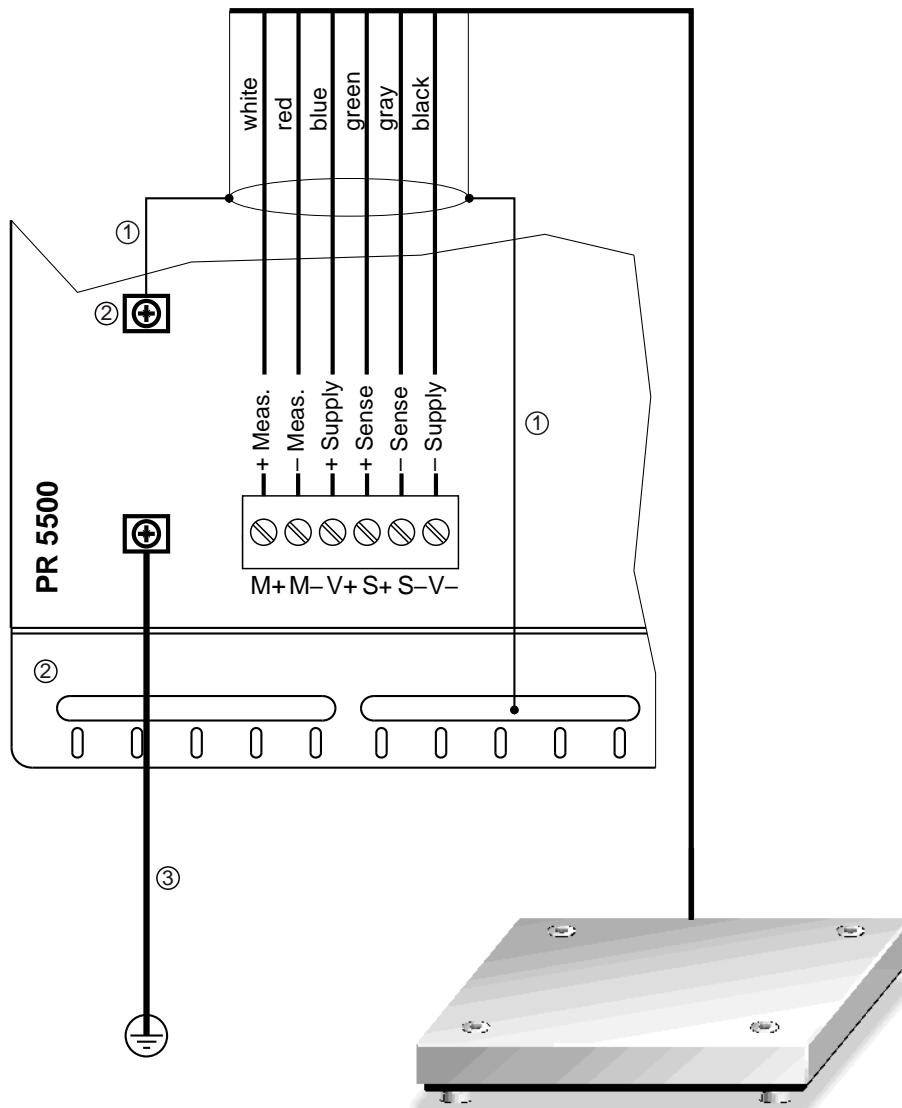

- ① Screen
- ② Grounding terminal or screen clamping rail
- ③ Equipotential bonding conductor

4.5.5 PR 5500/12 digital inputs and outputs

The plug-in card has 4 passive opto-decoupled inputs for process control.

The plug-in card also has 4 relay outputs with potential-free change-over contacts for process control.

The card is inserted in the option 1/FB and/or option 2 slot.

A maximum of 2 PR 5500/12 plug-in cards can be installed.

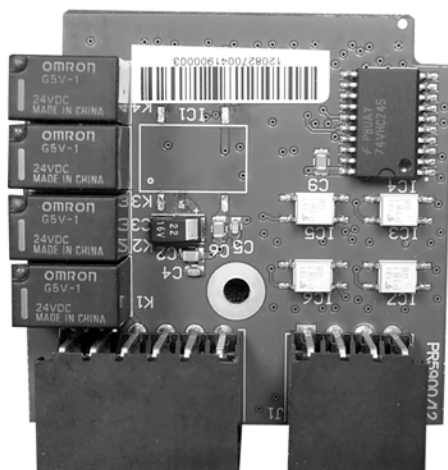

Technical data

Description	Data
Internal connection	Contact strip
External connection	2 x terminal, 6-pin 2 x terminal, 4-pin Wire gauge max. 1.5 mm ²
Number of inputs/outputs	4 (CH1, CH2, CH3, CH4)
Input voltage	Logic 0: U _{DC} = 0 to 5 V or open Logic 1: U _{DC} = 10 to 28 V Passive, external power supply required
Input current	<7 mA @ 24 V <3 mA @ 12 V Protection against incorrect polarity
Input frequency	Max. 200 Hz (50% ratio)
Output	Change-over contact Max. switching voltage: U _{DC} = 30 V/U _{AC} = 24 V Max. switching current: 1 A
Switching frequency	Max. 0.5 Hz
Potential isolation	Inputs: Yes, via optocoupler Outputs: Free relay change-over contact
Cables	Screened Connect cable screen to the device.
Cable length	Max. 50 m
Dimensions (L×W×H)	60×106×22 mm
Weight	70 g

4.5.5.1 Digital inputs (PR 5500/12)

Depicted: Terminal coding and internal circuitry

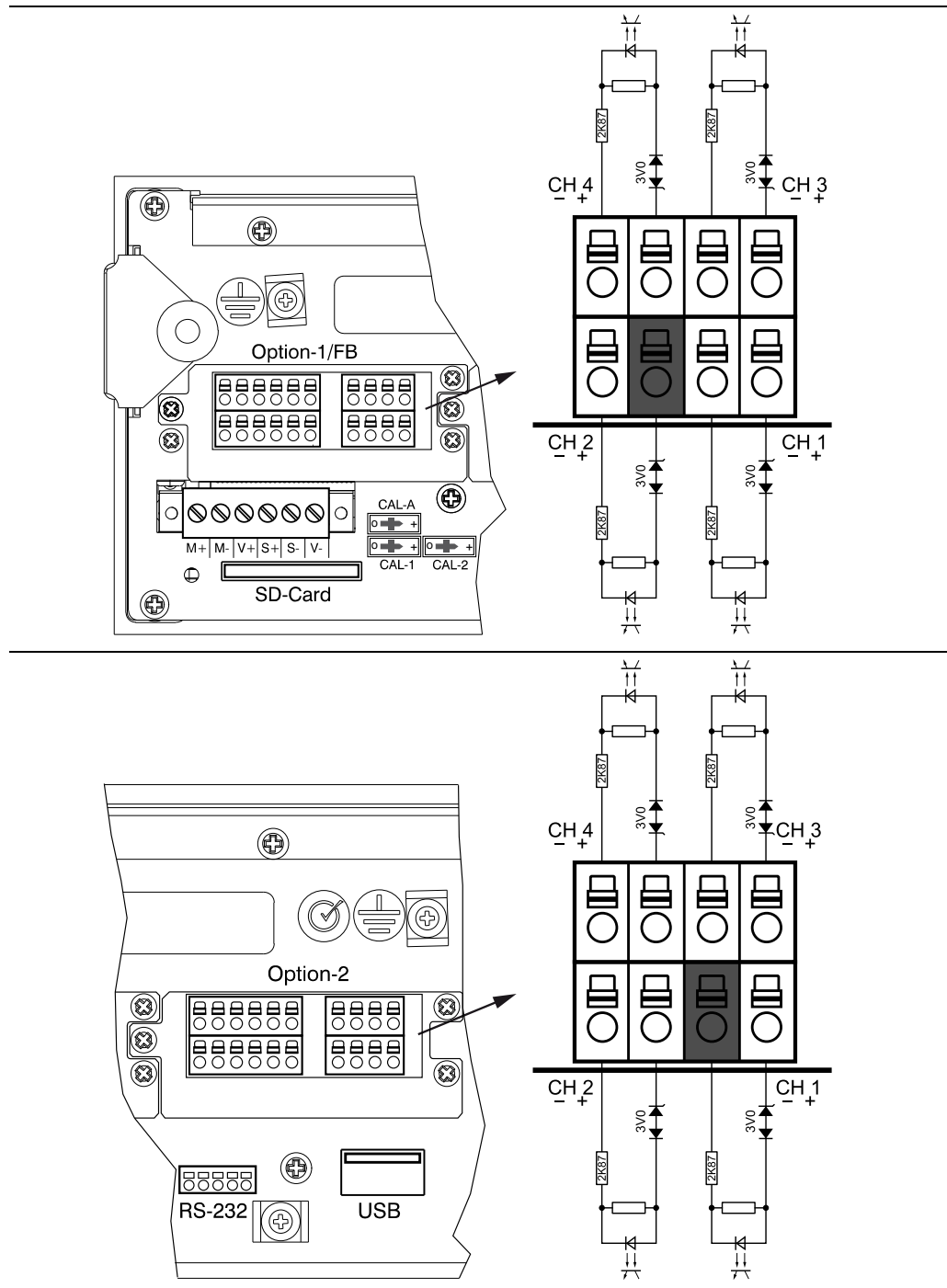

Coding for option 1 and option 2

Terminal strip: Insert the coding pin into the slot in the position marked in gray in the image.

Terminal: Remove (nip off) the relevant coding nib.

Note:

Refer to Chapter [5.2.3.3](#) for further information on terminal coding.

Example:

Connection for PR 5500/12: Digital inputs

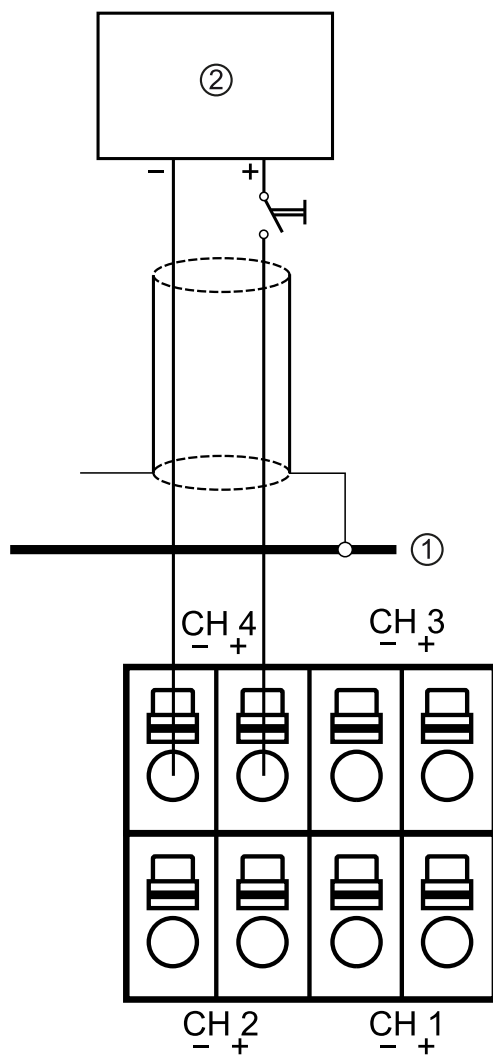

① Grounding terminal or screen clamping rail

② $U_{DC} = 24\text{ V } 0.5\text{ A}$ power supply unit

4.5.5.2 Digital outputs (PR 5500/12)

Depicted: Terminal coding and internal circuitry

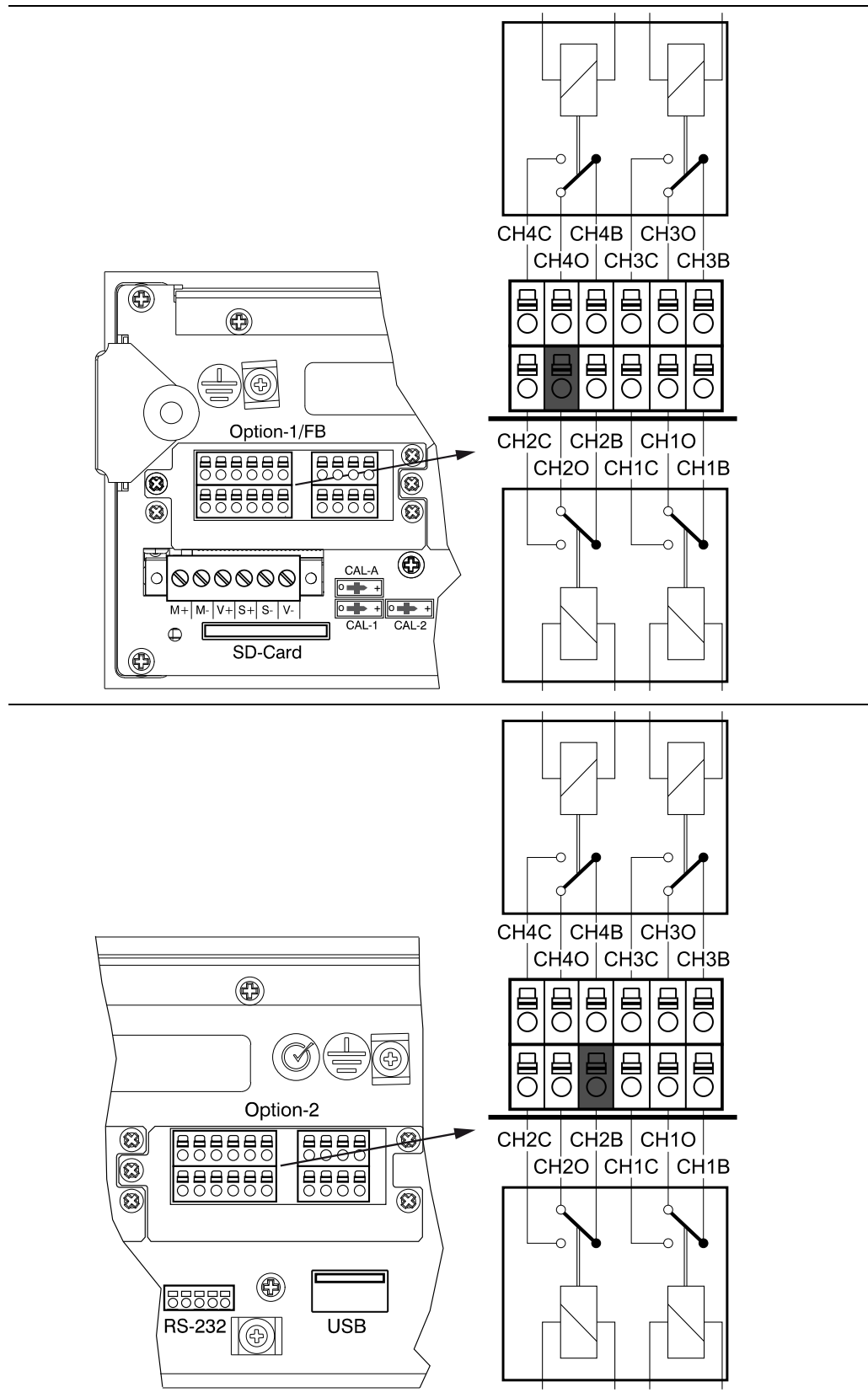

Coding for option 1 and option 2

Terminal strip: Insert the coding pin into the slot in the position marked in gray in the image.

Terminal: Remove (nip off) the relevant coding nib.

Note:

Refer to Chapter [5.2.3.3](#) for further information on terminal coding.

Example:

Connection for PR 5500/12: Relay control (power output)

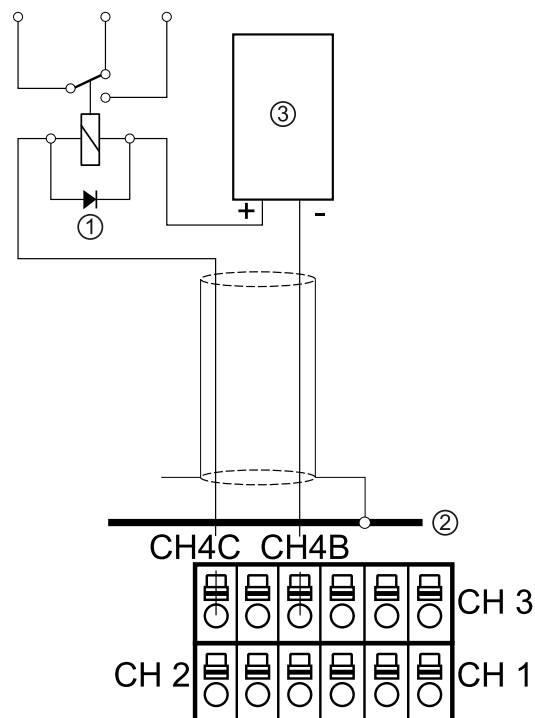

- ① Inductive load for free-wheel diode
- ② Grounding terminal or screen clamping rail
- ③ $U_{DC} = 24\text{ V } 0.5\text{ A}$ power supply unit

The relay switches when the output is active (true).

To protect the output circuit, relays must be equipped with free-wheel diodes.

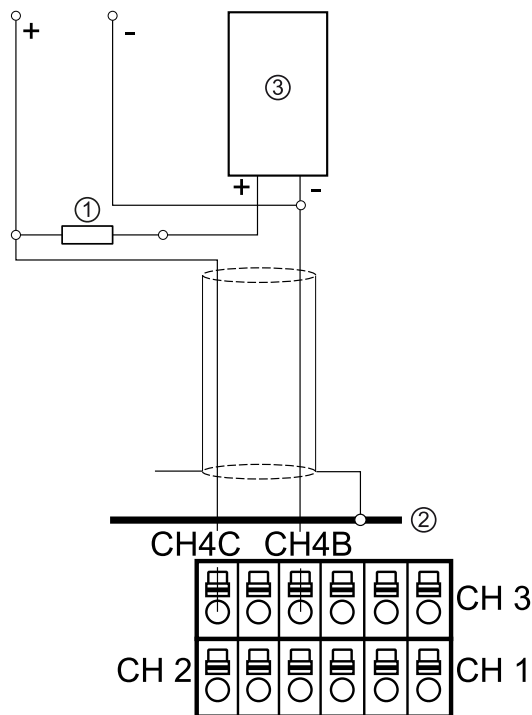
Example:**Connection for PR 5500/12: Voltage output**

- ① 2.2 k Ω /1 k Ω with 24 V/12 V
- ② Grounding terminal or screen clamping rail
- ③ $U_{DC} = 24\text{ V } 0.5\text{ A}$ power supply unit

When the output is active (true), the output voltage drops from 24 V/12 V to 0 V. The load resistance must be 2.2 k Ω /1 k Ω .

4.5.6 PR 5500/13 digital inputs and outputs

The plug-in card has 4 active opto-decoupled inputs for process control.

The plug-in card also has 4 relay outputs with potential-free change-over contacts for process control.

The card is inserted in the option 1/FB and/or option 2 slot.

A maximum of 2 PR 5500/13 plug-in cards can be installed.

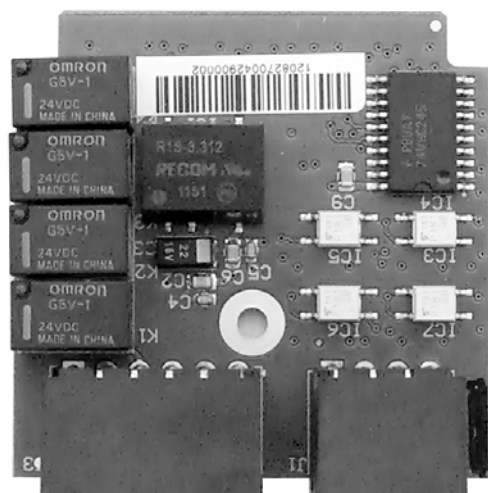

Technical data

Description	Data
Internal connection	Contact strip
External connection	2× terminal, 6-pin 2× terminal, 4-pin Wire gauge max. 1.5 mm ²
Number of inputs/outputs	4 (CH1, CH2, CH3, CH4)
Input	Can be switched via a potential-free contact
Input frequency	Max. 200 Hz
Output	Change-over contact Max. switching voltage: U _{DC} = 31 V/U _{AC} = 24 V Max. switching current: 1 A
Switching frequency	Max. 0.5 Hz
Potential isolation	Inputs: Jointly supplied via potential-free voltage Outputs: Free relay change-over contact
Cables	Screened Connect cable screen to the device.
Cable length	Max. 50 m
Dimensions (L×W×H)	60×106×22 mm
Weight	70 g

4.5.6.1 Digital inputs (PR 5500/13)

Depicted: Terminal coding and internal circuitry

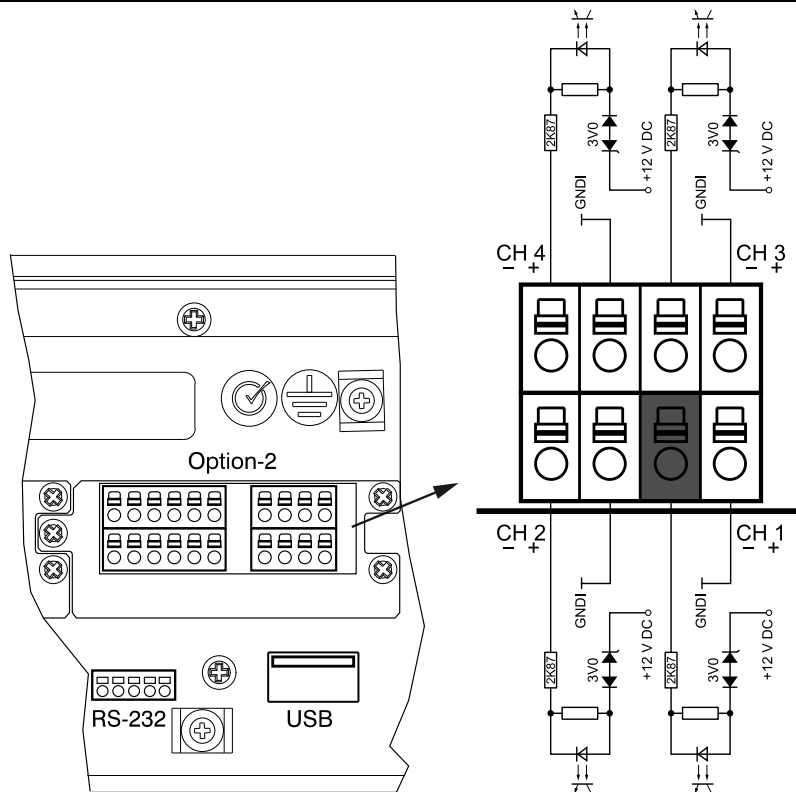
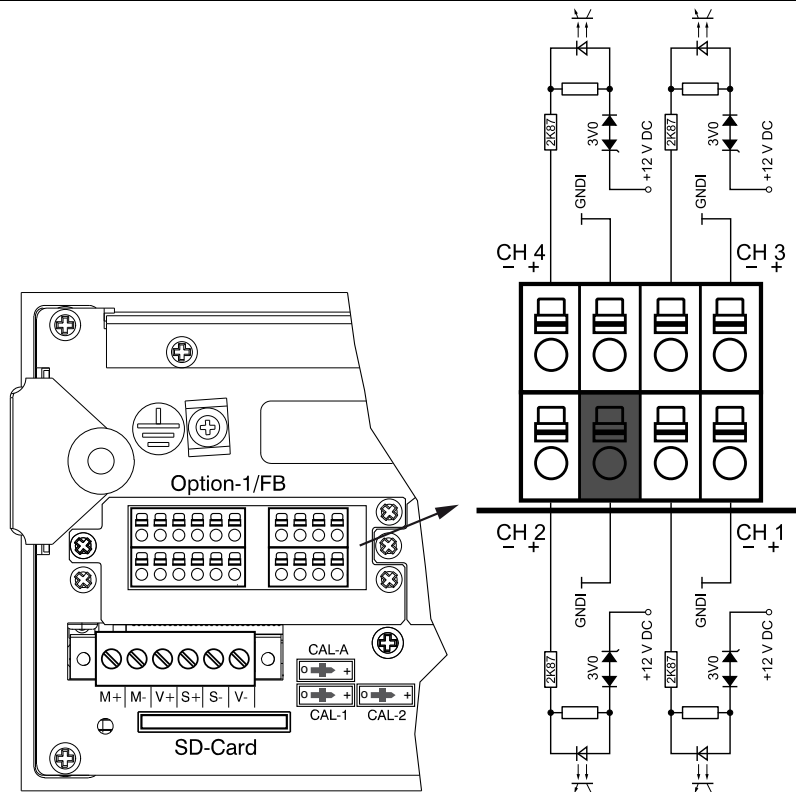

Coding for option 1 and option 2

Terminal strip: Insert the coding pin into the slot in the position marked in gray in the image.

Terminal: Remove (nip off) the relevant coding nib.

Note:

Refer to Chapter [5.2.3.3](#) for further information on terminal coding.

Example:

Connection for PR 5500/13: Digital inputs

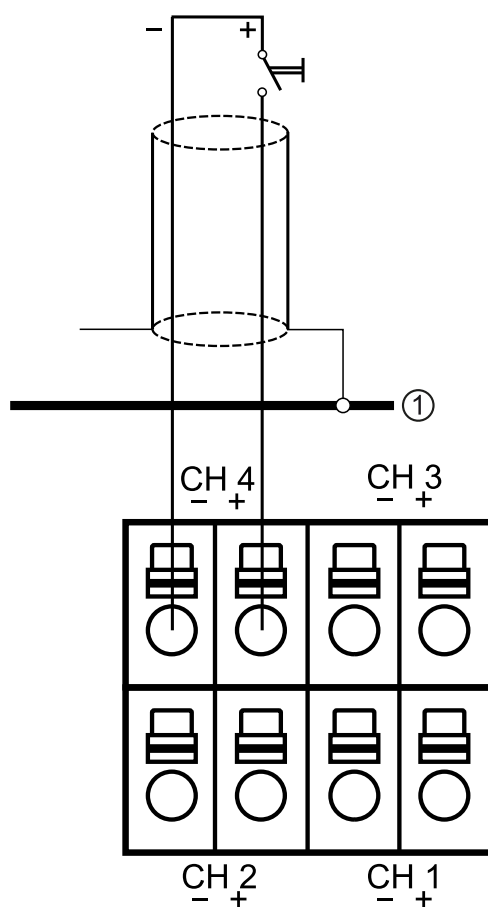

① Grounding terminal or screen clamping rail

4.5.6.2 Digital outputs (PR 5500/13)

Depicted: Terminal coding and internal circuitry

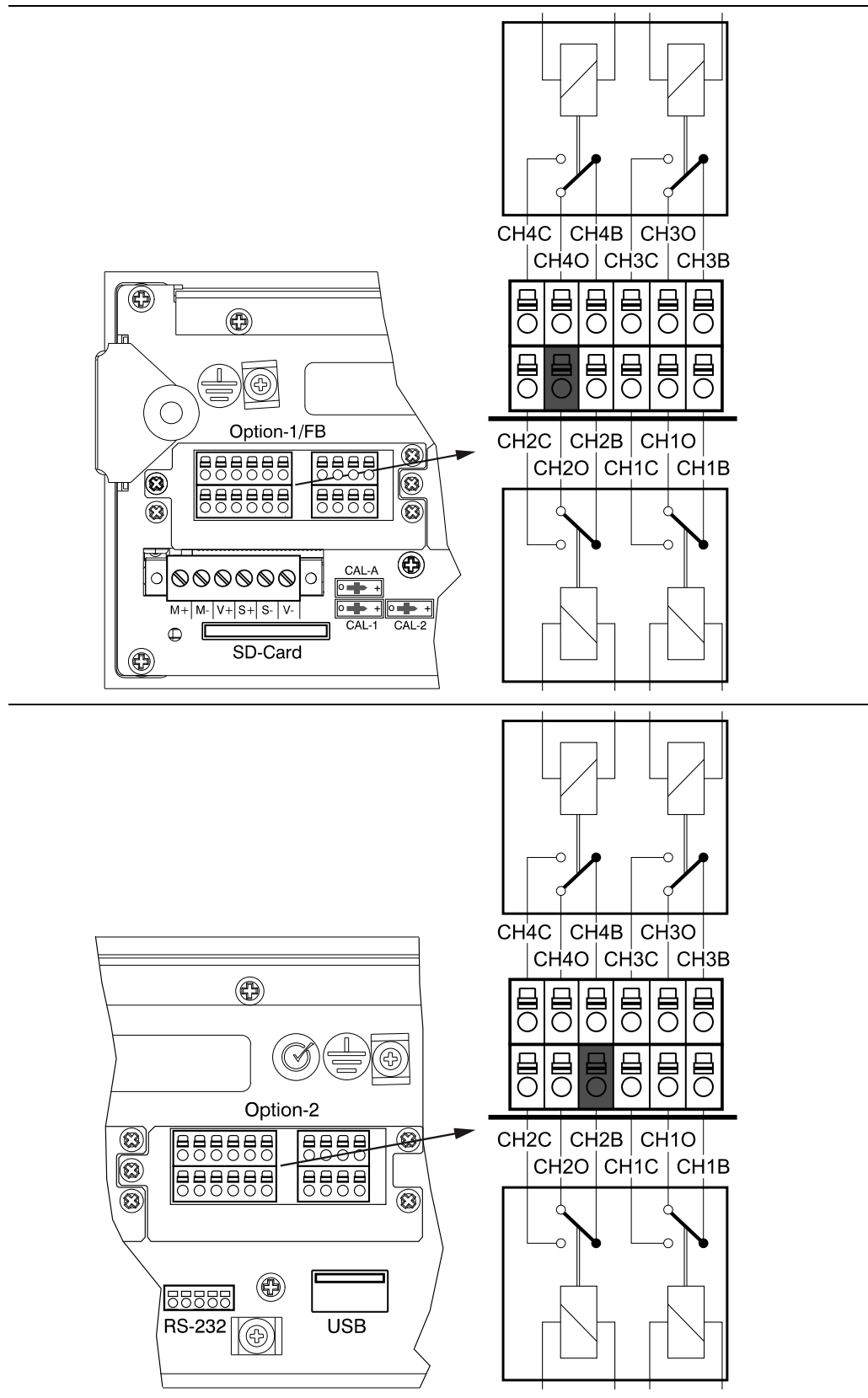

Coding for option 1 and option 2

Terminal strip: Insert the coding pin into the slot in the position marked in gray in the image.

Terminal: Remove (nip off) the relevant coding nib.

Note:

Refer to Chapter [5.2.3.3](#) for further information on terminal coding.

Example:

Connection for PR 5500/13: Relay control (power output)

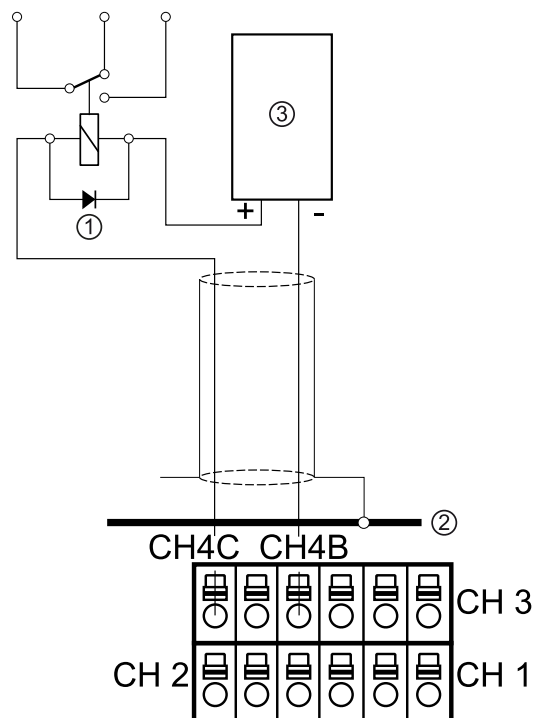

- ① Inductive load for free-wheel diode
- ② Grounding terminal or screen clamping rail
- ③ $U_{DC} = 24\text{ V } 0.5\text{ A}$ power supply unit

The relay switches when the output is active (true).

To protect the output circuit, relays must be equipped with free-wheel diodes.

Example:

Connection for PR 5500/13: Voltage output

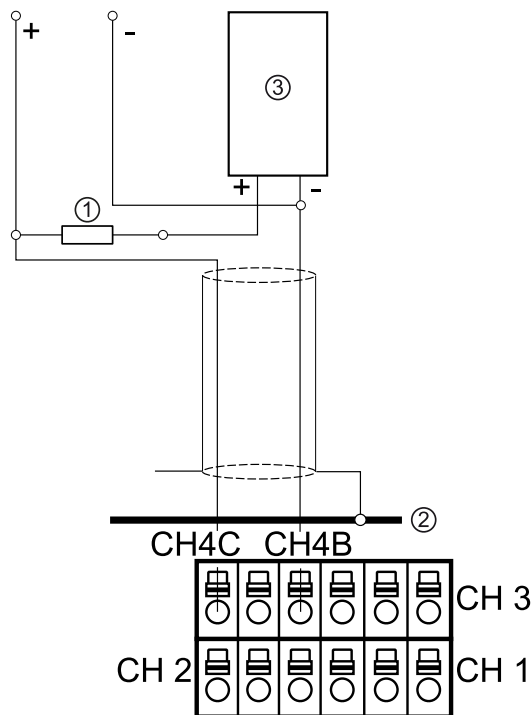

- ① 2.2 k Ω /1 k Ω with 24 V/12 V
- ② Grounding terminal or screen clamping rail
- ③ $U_{DC} = 24\text{ V } 0.5\text{ A}$ power supply unit

When the output is active (true), the output voltage drops from 24 V/12 V to 0 V. The load resistance must be 2.2 k Ω /1 k Ω .

4.5.7 PR 5500/17 digital inputs and outputs

The plug-in card has 6 passive opto-decoupled inputs and 8 passive opto-decoupled outputs for process control.

All inputs and outputs have a common GND (-).

The card is inserted in the option 1/FB and/or option 2 slot.

A maximum of 2 PR 5500/17 plug-in cards can be installed.

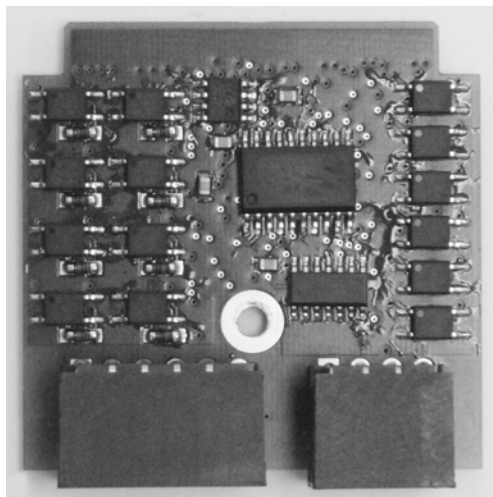

Technical data

Description	Data
Internal connection	Contact strip
External connection	2× terminal, 6-pin 2× terminal, 4-pin Wire gauge max. 1.5 mm ²
Number of inputs	6 (CH1, CH2, CH3, CH4, CH5, CH6)
Input voltage	Low: 0 to 5 V High: 10 to 28 V Passive, external power supply required
Input current	<7 mA @ 24 V <3 mA @ 12 V
Number of outputs	8 (CH1, CH2, CH3, CH4, CH5, CH6, CH7, CH8)
Output supply voltage	Max. 24 V +10% external to connector
Output voltage drop	$I_{Load} * 55 \Omega + 1V$ (output conducting)
Output max. switching current	25 mA
Signals	GND (-) common for all inputs and outputs
Potential isolation	Yes, via optocoupler
Cables	Screened Connect cable screen to the device.
Cable length	Max. 50 m
Dimensions (L×W×H)	52×52×19 mm
Weight	50 g

4.5.7.1 Digital inputs (PR 5500/17)

Depicted: Terminal coding and internal circuitry

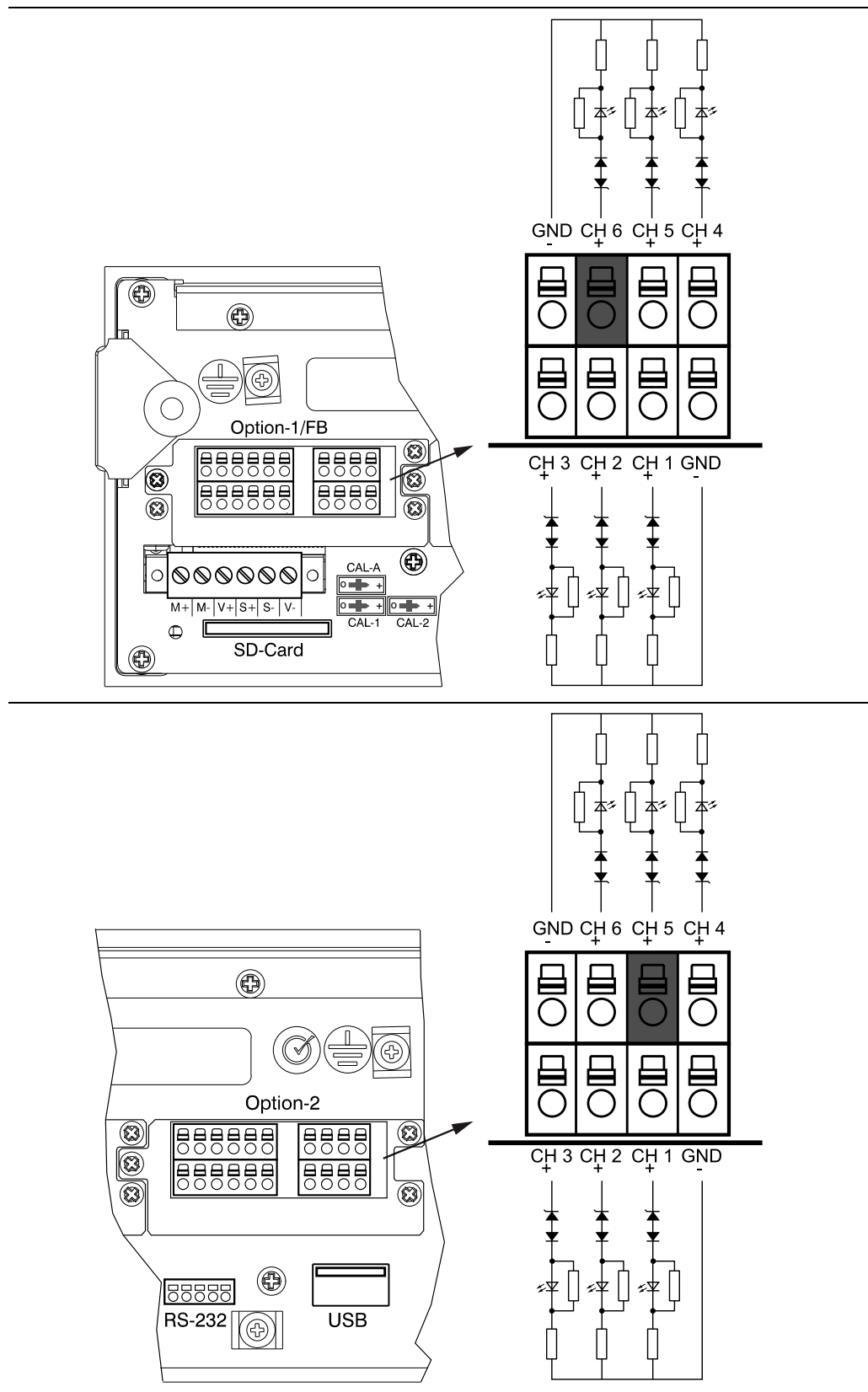

Coding for option 1 and option 2

Terminal strip: Insert the coding pin into the slot in the position marked in gray in the image.

Terminal: Remove (nip off) the relevant coding nib.

Note:

Refer to Chapter [5.2.3.3](#) for further information on terminal coding.

Example:

Connection for PR 5500/17: Digital inputs

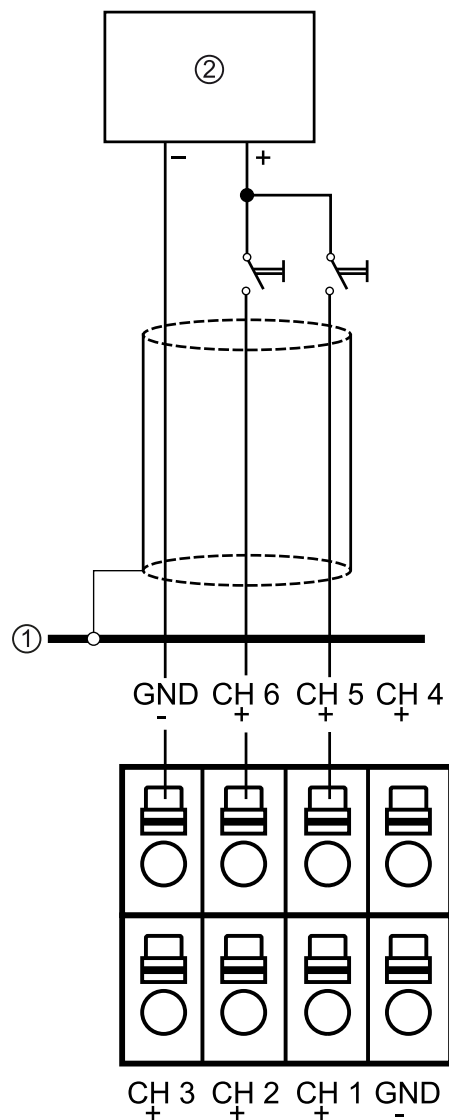

① Grounding terminal or screen clamping rail

② Power supply unit $U_{DC} = 24\text{ V } 0.5\text{ A}$

Example:

Connection for PR 5500/17: Digital inputs without potential isolation

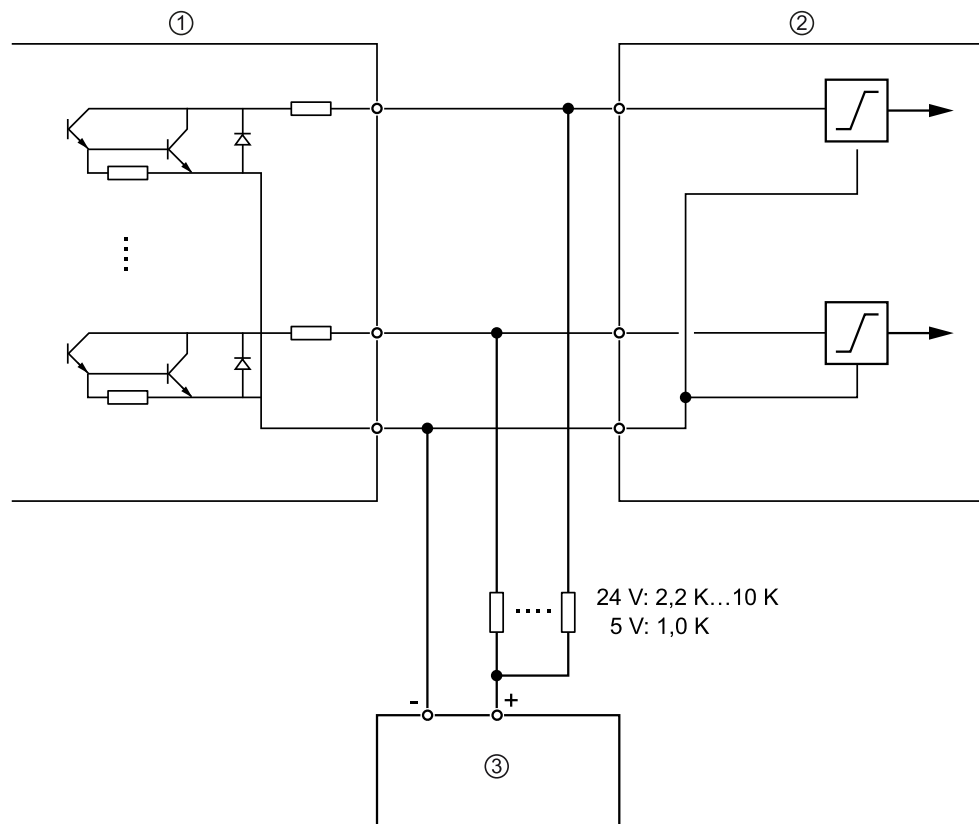

- ① PR 5500/17
- ② PLC
- ③ Power supply

Example:

Connection for PR 5500/17: Digital inputs with potential isolation

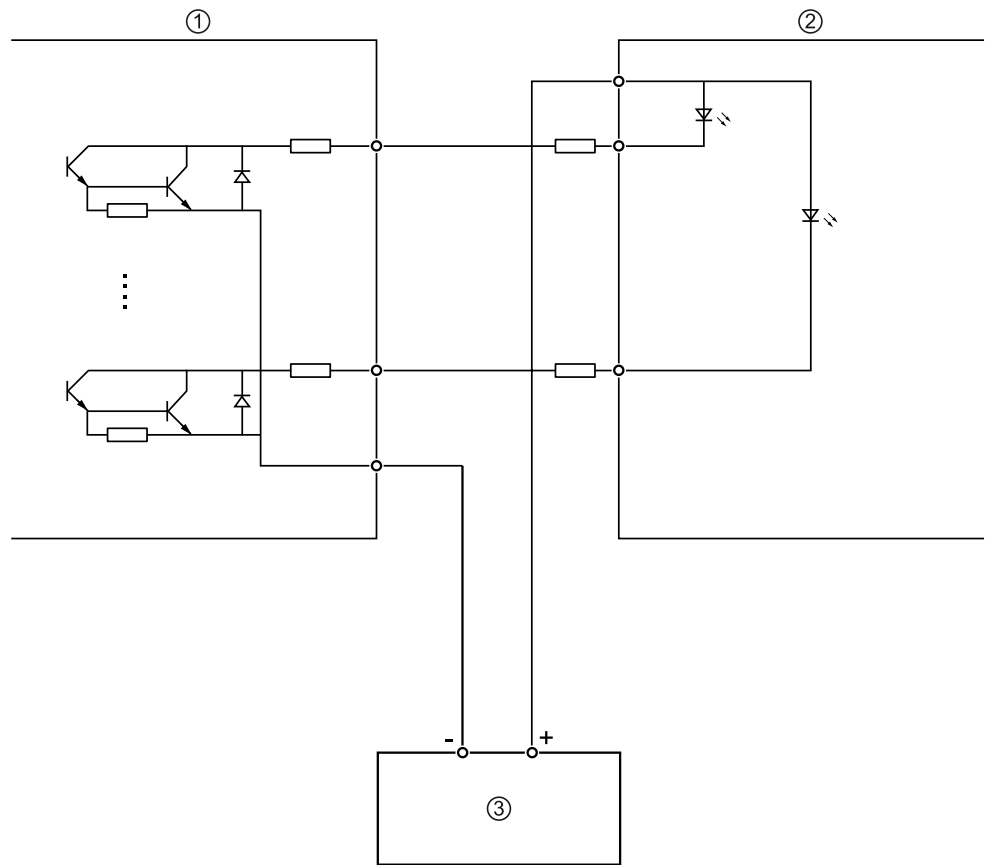

- ① PR 5500/17
- ② PLC
- ③ Power supply

4.5.7.2 Digital outputs (PR 5500/17)

Depicted: Terminal coding and internal circuitry

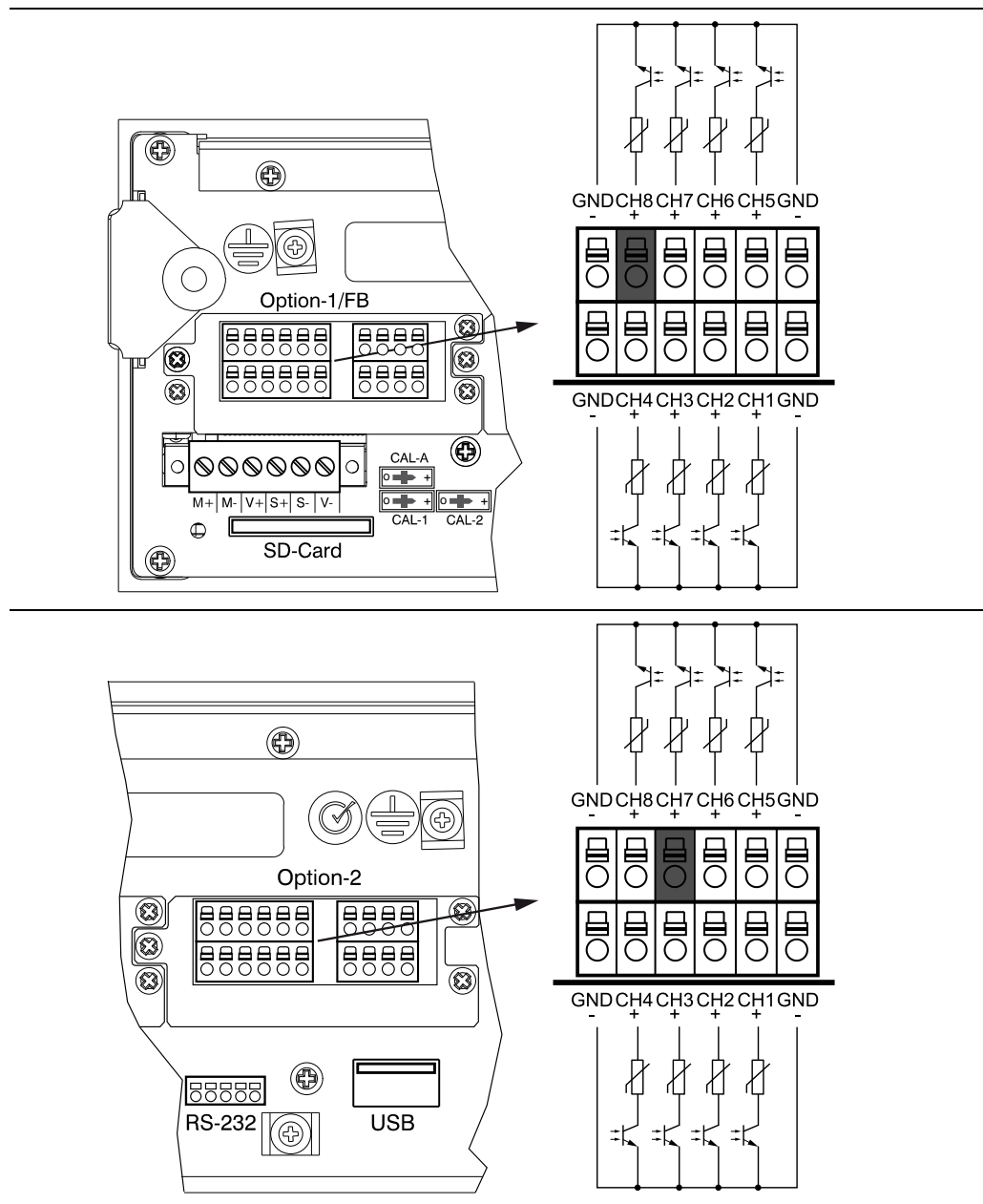

Coding for option 1 and option 2

Terminal strip: Insert the coding pin into the slot in the position marked in gray in the image.

Terminal: Remove (nip off) the relevant coding nib.

Note:

Refer to Chapter [5.2.3.3](#) for further information on terminal coding.

Example:

Connection for PR 5500/17: Relay control (power output)

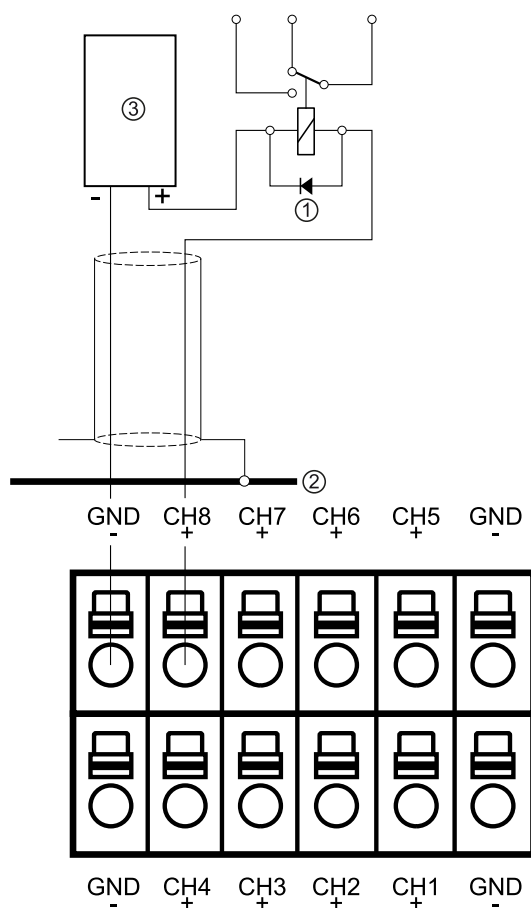

- ① Inductive load for free-wheel diode
- ② Grounding terminal or screen clamping rail
- ③ $U_{DC} = 24\text{ V } 0.5\text{ A}$ power supply unit

The relay switches when the output is active (true).

To protect the output circuit, relays must be equipped with free-wheel diodes.

4.5.8 ProfiBus DP interface

The ProfiBus DP interface card has the type designation PR 1721/61.

Communication protocols and syntax comply with the ProfiBus-DP standard to IEC 61158, with transfer rates up to 12 Mbit/s.

Connection to the ProfiBus is established using the 9-pin D-Sub female connector on the back of the device.

The card is inserted in the Option 1/FB slot (see Chapter 5.2.3).

Technical data

Description	Data
Internal connection	Pin strip, 50-pin
External connection	9-pin D-Sub female connector in module cover
Transfer rate	9.6 kbit/s to 12 Mbit/s, baud rate auto-detection
Connection mode	Profibus network, connections can be made/released without affecting other stations.
Protocol	PROFIBUS-DP-V0 SLAVE to IEC 61158
Configuration	GSD file "SART_5500.gsd"
Potential isolation	Yes, optocoupler in lines A and B (RS-485)
Bus termination	The bus termination in the last device is implemented via the integrated terminating resistor in the Profibus plug.
Cable type	Profibus "special"; color: violet; screened twisted pair cable
Cable impedance	150 Ω
Cable length	The max. distance of 200 m can be extended at 1.5 Mbit/s by means of an additional repeater.
Dimensions (LxWxH)	55x50x22 mm
Weight	Approx. 33 g
Certificates	Profibus test center Comdec in Germany and PNO (Profibus User Organization). Industry-compatible CE, UL, and cUL

Note:

The GSD file is stored on the CD supplied with the device (fieldbus directory of the respective device). The current file is also available to download online:

<http://www.minebea-intec.com>

Profibus connection

The device is the only/last slave in the bus:

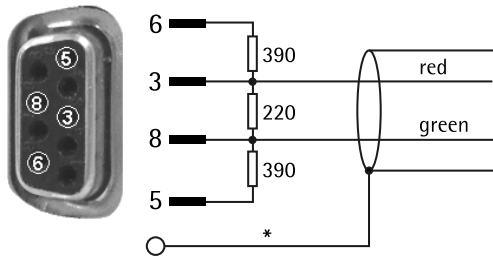

* screen on connector housing

The device is not the only/last slave in the bus:

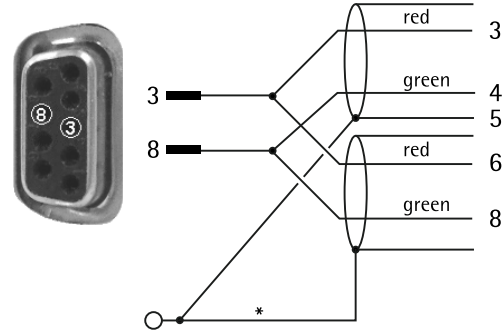

* screen on connector housing

e.g.: D-Sub bus plug SIMATIC NET PROFIBUS FAST CONNECT

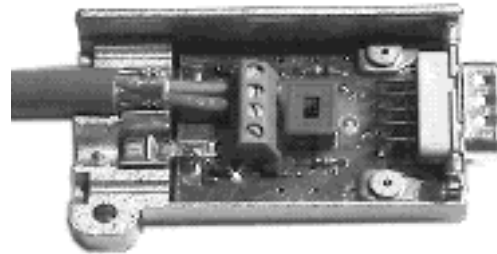

Allocation of the 9-pin D-sub female connector

Pin assignment	Signal	Color	Description
Housing -----	S		Screen
1			Not connected
2			Not connected
3 -----	RxD/TxD-P (positive) according to RS-485 specification	Red	Send/receive data Data core B/D (P)
4 if required	RTS		"Request To Send" (only when using a repeater)
5 -----	DGND		Insulated GND to RS-485 side
6 -----	VP		Insulated power supply +5 V to RS-485 side
7			Not connected
8 -----	RxD/TxD-N (negative) according to RS-485 specification	Green	Send/receive data Data core A/D (N)
9			Not connected

Note:

Only plug connections with integrated terminating resistors may be used.

The terminating resistor must be turned on in the last slave.

4.5.8.1 LEDs

Identification	Description
OP	Operating mode LED
ST	Status LED

Operating mode (OP)

LED status	Description	Comments
Off	Module is offline.	No power
Constant green	Module is online.	Data exchange is possible.
1 Hz flashing green	Module is online.	Module is ready for data exchange.
1 Hz flashing red	Parameter error	
2 Hz flashing red	Module configuration error	

Module status (ST)

LED status	Description	Comments
Off	Module is not initialized.	- No power - Module has the status "SETUP" or "NW_INIT".
Constant green	Module is initialized.	Normal operation
Constant red	Exception error	- Module has the status "EXCEPTION" - The exception error monitoring system closes all open connections to the module.

4.5.9 DeviceNet interface

The DeviceNet interface card has the type designation PR 1721/64.

The fieldbus card contains all functionalities to make a complete DeviceNet slave with a CAN controller and transmission speeds up to 500 kbit/s.

The DeviceNet connection is established by 5-pin terminal.

The card is inserted in the Option 1/FB slot, see Chapter [5.2.3](#).

Technical data

Description	Data
Internal connection	Pin strip, 50-pin
External connection	5-pin terminal (plug-in) in the module cover
Transfer rate	125, 250 and 500 kbit/s
Protocol	DeviceNet Master Slave <ul style="list-style-type: none"> - Polling procedure (polled IO) - CRC error recognition according to IEC 62026 (EN 50325) - Max. 64 station nodes - Data width max. 512 byte "input & output"
Configuration	EDS file "sag_5500.eds" MAC-ID (1...62)
Potential isolation	Yes, optocoupler and DC/DC converter
Bus termination	120 Ω at the cable ends
Bus load	33 mA @ $U_{DC} = 24$ V
Cable type	DeviceNet; color: petrol green; 2x2 twisted pair; screened
Cable impedance	150 Ω
Dimensions (LxWxH)	55x50x22 mm
Weight	Approx. 33 g
Certificates	<ul style="list-style-type: none"> - Compatible with DeviceNet specification Vol. 1: 2.0, Vol 2: 2.0 - ODVA Certificate according to conformity test software version A-12 - Industry-compatible CE, UL, and cUL

Note:

The EDS file is stored on the CD supplied with the device (fieldbus directory of the respective device). The current file is also available to download online:

<http://www.minebea-intec.com>

DeviceNet terminal

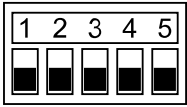

Allocation of the 5-pin terminal

Pin assignment	Signal	Color	Description
Cable sheath			Special DeviceNet cable (certified)
1 -----	V-	black	Negative power supply
2 -----	CAN_L	Blue	CAN_L bus signal
3 -----	S		Cable screen
4 -----	CAN_H	white	CAN_H bus signal
5 -----	V+	Red	Positive power supply

4.5.9.1 LEDs



Identifi- cation	Description
NS	Network status LED
MS	Module status LED

Network status (NS)

LED status	Description	Comments
Off	Module is offline.	No power
Constant green	Module is online.	There are one or more connections.
1 Hz flashing green	Module is online.	No connections
Constant red	Critical connection error	
1 Hz flashing red		One or more connections has exceeded the connection time limit
Flashing red/green in alternation	Self-test running.	

Module status (MS)

LED status	Description	Comments
Off	Module is not initialized.	<ul style="list-style-type: none"> - No power - Module has the status "SETUP" or "NW_INIT".
Constant green	Module is initialized.	Normal operation
1 Hz flashing green	Missing or incomplete configuration	The device must be set up again.
Constant red	Exception error	<ul style="list-style-type: none"> - Module has the status "EXCEPTION" - The exception error monitoring system closes all open connections to the module.
1 Hz flashing red	Error that can be corrected	
Flashing red/green	Self-test running.	

4.5.9.2 Connection diagram for a master with three slaves

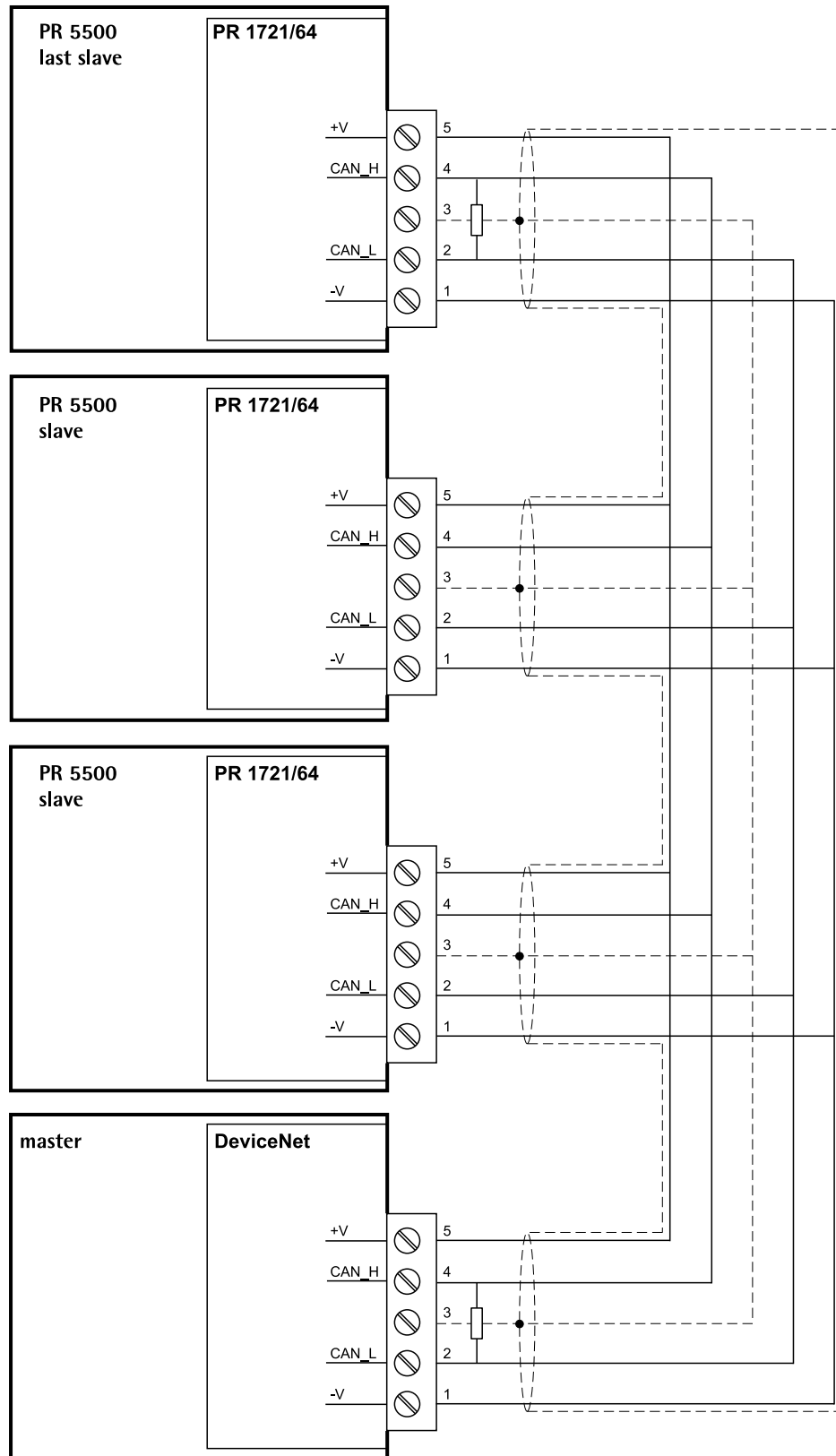

PR 5500/.. receives 33 mA from the DeviceNet bus supply.

4.5.10 CC-Link interface

The CC-Link interface card has the type designation PR 1721/65.

The fieldbus card contains all functions to provide a complete CC-Link slave with transfer rates up to 10 Mbps.

The CC-Link connection is established by the 5-pin terminal.

The card is inserted in the Option 1/FB slot, see Chapter [5.2.3](#).

Technical data

Designation	Data
Internal connection	Pin strip, 50-pin
External connection	5-pin terminal (plug-in) in the module cover
Transfer rate	156; 625 kbps; 2.5; 5, 10 Mbps
Protocol	CC-Link slave <ul style="list-style-type: none"> - CRC error recognition according to IEC 62026 (EN 50325) - Max. 64 station nodes - 128 I/O bits and 16 (32 bit) words
Configuration	CSPP file "0x0608_Maxxis_4_1.00_en.CSPP"
Potential isolation	Yes, optocoupler and DC/DC converter
Bus termination	110 Ω at the cable ends
Bus load	100 mA
Cable type	2x2 screened twisted pair
Cable length	100 m @ 10 Mbps, 1200 m @ 156 kbps
Dimensions (LxWxH)	55x50x22 mm
Weight	Approx. 33 g
Certificates	<ul style="list-style-type: none"> - Type: ABCC-CCL (CC-Link CARD) (H/W: from 1.03, S/W: from 1.03, CC-Link: 1.10) - Reference no.: 1102

Note:

The CSPP file is stored on the CD supplied with the device (Fieldbus directory of the respective device). The current file is also available for download via the Internet:

<http://www.minebea-intec.com>

CC-Link terminal

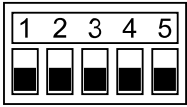

Allocation of the 5-pole terminal block

Pin assignment	Signal	Description
1-----	DA	Communication RS-485 RxD/TxD (+)
2-----	DB	Communication RS-485 RxD/TxD (-)
3-----	GND	Digital ground
4-----	S	Cable screen
5-----	PE, according to AnyBus S-specification	Housing ground

4.5.10.1 LEDs



Identification	Description
RUN	LED sequence
ERR	LED error

Sequence (RUN)

LED status	Description	Comments
Off	Module is offline.	<ul style="list-style-type: none"> - No network connection - No power
Constant green	Module is online.	<ul style="list-style-type: none"> - Network connection exists - Normal operation
Constant red	Exception error	<ul style="list-style-type: none"> - Module has the status "EXCEPTION" - The exception error monitoring system closes all open connections to the module.

Error (ERR)

LED status	Description	Comments
Off	No error	No power
Constant green	Exception error	<ul style="list-style-type: none"> - Module has the status "EXCEPTION" - The exception error monitoring system closes all open connections to the module.
Flickering red	CRC error	
1 Hz flashing red	<ul style="list-style-type: none"> - Error address - Error baud rate 	After possible changes: <ul style="list-style-type: none"> - Invalid address - No permissible baud rate

4.5.11 ProfiNet I/O interface

The ProfiNet I/O interface card has the type designation PR 1721/66 or PR 1721/76.

The fieldbus card is equipped with a standard RJ-45 socket (PR 1721/66) or two standard RJ-45 sockets (PR 1721/76) for network connection.

It contains powerful UDP/IP connecting circuitry with transfer rates of 10 and 100 Mbit/s.

The card is inserted in the Option 1/FB slot, see Chapter [5.2.3](#).

Technical data

Description	Data
Internal connection	Pin strip, 50-pin
External connection	One RJ-45 socket (PR 1721/66) or two standard RJ-45 sockets (PR 1721/76) in the module cover
Transfer rate	10 Mbit/s and 100 Mbit/s Auto-detection (10/100, HalfDX/FullDX)
Protocol	ProfiNet I/O
Connection mode	Network
Configuration	XML file PR 1721/66 "GSDML-Vx.xx-Sartorius-PR5500-xxxxxx.xml" PR 1721/76 "GSDML-Vx.xx-Minebea-PR5500-2-Port-xxxxxx.xml"
Potential isolation	Yes
Cable type	Twisted pairs, screened, e.g., patch cable CAT5 Autolink (straight or crossover)
Cable impedance	150 Ω
Cable length to HUB	Max. 115 m
Dimensions (LxWxH)	55x50x22 mm

Description	Data
Weight	Approx. 33 g
Certificate	ProfiBus Nutzerorganisation e.V. for HMS Industrial Networks AB Certificate no.: Z10931 Report: PN005-1, 02/12/2007.

Note:

The ProfiNet I/O card PR 1721/76 is supported by software version 2.24 and device serial number 30363xxxxx or higher.

The S2 redundancy of the ProfiNet I/O card PR 1721/76 is supported by software version 2.26.18 or higher.

The IP address and subnet mask are set under [Fieldbus parameters] (see the PR 5500 operating manual under [System setup] - [Fieldbus parameters] - [ProfiNet I/O])

The XML file is stored on the CD supplied with the device (fieldbus directory of the respective device). The current file is also available to download online:

<http://www.minebea-intec.com>

Note:**Fieldbus parameters**

Recommendation for a Siemens S7, for example

- ▶ Fieldbus slave setting:
- ▶ Use DHCP [on] as per the default settings and activate the master as a DHCP server (W [Allocate IP adr via IO controller]).

NOTICE**Slave – master device names**

A unique device name must be assigned out of the master. This name is given highest priority when establishing a connection.

- ▶ When replacing devices or servicing, please note:
- ▶ As well as the IP address, the device name must correspond to that of the replacement device. Explicit assignment out of the master is required.

Example:

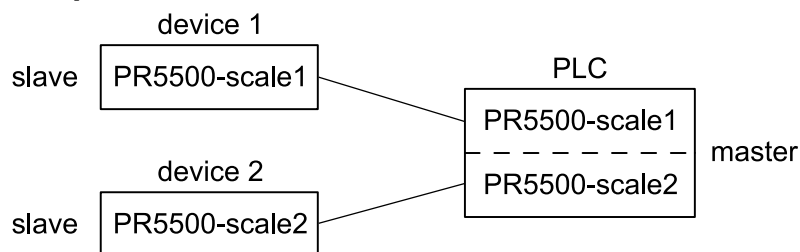

4.5.11.1 LEDs

PR 1721/66

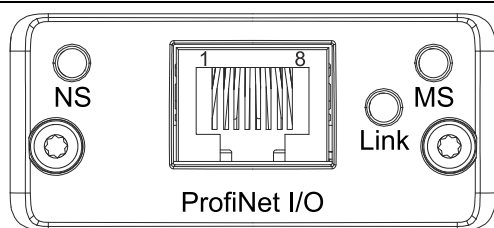

Identifi- cation	Description
NS	Network status LED
MS	Module status LED
Link	Link/Activity LED

Network status (NS)

LED status	Description	Comments
Off	Module is offline.	<ul style="list-style-type: none"> - No power - No connection to the I/O controller
Constant green	Module is online (RUN).	<ul style="list-style-type: none"> - There is a connection to the I/O controller. - I/O controller is operational (RUN status).
1 Hz flashing green	Module is online (STOP).	<ul style="list-style-type: none"> - There is a connection to the I/O controller. - I/O controller is not operational (STOP status).

Module status (MS)

LED status	Description	Comments
Off	Module is not initialized.	<ul style="list-style-type: none"> - No power - Module has the status "SETUP" or "NW_INIT".
Constant green	Module is initialized.	Normal operation
1 Hz flashing green	Error after test	Error occurred after test.
2 Hz flashing green		This is used for node identification in the network.

LED status	Description	Comments
Constant red	Exception error	<ul style="list-style-type: none"> - Module has the status "EXCEPTION" - The exception error monitoring system closes all open connections to the module.
1 Hz flashing red	Configuration error	Expected identification deviates from the available identification.
2 Hz flashing red	IP address error	IP address was not defined.
3 Hz flashing red	Device name error	Device name was not defined.
4 Hz flashing red	Internal error	Module has caused an unrecoverable internal error.

Link/Activity

LED status	Description	Comments
Off	Module has no connection.	<ul style="list-style-type: none"> - No connection - No communication
Constant green	Module has a connection.	<ul style="list-style-type: none"> - There is an Ethernet connection. - No communication
Flickering green	Activity	<ul style="list-style-type: none"> - There is an Ethernet connection. - Communication is available.

PR 1721/76

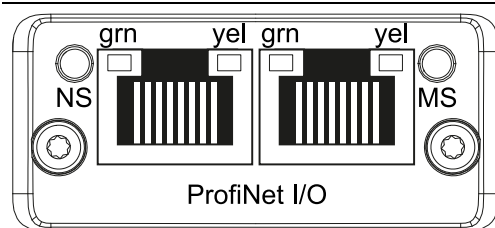

Identifi- cation	Description
NS	Network status LED
MS	Module status LED
grn	Green: flashes when there is data traffic (activity)
yel	Yellow: lights up when there is an existing connection (link)

Network status (NS)

LED status	Description	Comments
Off	Module is offline.	<ul style="list-style-type: none"> - No power - No connection to the I/O controller

LED status	Description	Comments
Constant green	Module is online (RUN).	<ul style="list-style-type: none"> - There is a connection to the I/O controller. - I/O controller is operational (RUN status).
1 Hz flashing green	Module is online (STOP).	<ul style="list-style-type: none"> - There is a connection to the I/O controller. - I/O controller is not operational (STOP status). - IRT synchronization is not complete.
3 Hz flashing green	Identification	Flashes continuously 3 times (1 Hz) in order to identify the slave (DCP_Identify).
Constant red	Critical event	Severe internal error This display is combined with the red module status LED.
1 Hz flashing red	Device name error	Device name was not defined.
2 Hz flashing red	IP address error	IP address was not defined.
3 Hz flashing red	Configuration error	Expected identification deviates from the available identification.

Module status (MS)

LED status	Description	Comments
Off	Module is not initialized.	<ul style="list-style-type: none"> - No power - Module has the status "SETUP" or "NW_INIT".
Constant green	Normal operation	Module no longer has the status "NW_INIT".
1 Hz flashing green	Diagnostic event	Diagnostic event(s) is/are running.
Constant red	Exception error	Module has the status "EXCEPTION"
	Critical event	Severe internal error This display is combined with the red network status LED.
Flashing green/red in alternation	Firmware update	Do not switch off the module. Switching off the module during an update may cause permanent damage.

4.5.12 EtherNet/IP interface

The EtherNet/IP interface card has the type designation PR 1721/67 or PR 1721/77.

The fieldbus card is equipped with a standard RJ-45 socket (PR 1721/67) or two standard RJ-45 sockets (PR 1721/77) for network connection.

It contains powerful UDP/IP connecting circuitry with transfer rates of 10 and 100 Mbit/s.

The card is inserted in the Option 1/FB slot, see Chapter [5.2.3](#).

Technical data

Description	Data
Internal connection	Pin strip, 50-pin
External connection	One RJ-45 socket (PR 1721/67) or two standard RJ-45 sockets (PR 1721/77) in the module cover
Transfer rate	10 Mbit/s and 100 Mbit/s Auto-detection (10/100, HalfDX/FullDX)
Protocol	EtherNet IP
Connection mode	Network
Configuration	EDS file PR 1721/67 "sag_5500_ethernetip.eds" PR 1721/77 "min_5500_ethernetip.eds"
Potential isolation	Yes
Cable type	Twisted pairs, screened, e.g., patch cable CAT5 Autolink (straight or crossover)
Cable impedance	150 Ω
Cable length to HUB	Max. 115 m
Dimensions (LxWxH)	55x50x22 mm
Weight	Approx. 33 g
Certificate	EtherNet IP specification <ul style="list-style-type: none"> - ODVA file no. 10286 - Test date: 9/6/2005 - Vendor ID 90 - See also: www.odva.org - Industry-compatible CE, UL, and cUL

Note:

The EtherNet/IP card PR 1721/77 is supported by software version 2.24 and device serial number 30363xxxxx or higher.

The IP address and subnet mask are set under [Fieldbus parameters] (see the PR 5500 operating manual under [System setup] - [Fieldbus parameters] - [EtherNet IP])

The EDS file is stored on the CD supplied with the device (fieldbus directory of the respective device). The current file is also available to download online:

<http://www.minebea-intec.com>

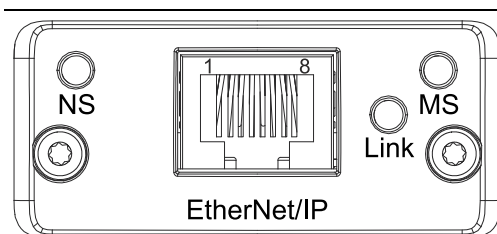
4.5.12.1 LEDs**PR 1721/67**

Identifi- cation	Description
NS	Network status LED
MS	Module status LED
Link	Link/Activity LED

Network status (NS)

LED status	Description	Comments
Off	Module is offline	- No power - No IP address
Constant green	Module is online	One or more connections exist (CIP class 1 or 3).
1 Hz flashing green	Module is online	No connection
Constant red	Critical connection error	Duplicate IP address
1 Hz flashing red		One or more connections has exceeded the connection time (CIP class 1 or 3).

Module status (MS)

LED status	Description	Comments
Off	Module is uninitialized	- No power - Module has the status "SETUP" or "NW_INIT".
Constant green	Module is initialized	Normal operation
1 Hz flashing green	Error after test	Error occurred after test.
2 Hz flashing green		This is used for node identification in the network.

LED status	Description	Comments
Constant red	Exception error	<ul style="list-style-type: none"> - Module has the status "EXCEPTION" - The exception error monitoring system closes all open connections to the module.
1 Hz flashing red	Configuration error	Expected identification deviates from the available identification.
2 Hz flashing red	IP address error	IP address was not defined.
3 Hz flashing red	Device name error	Device name was not defined.
4 Hz flashing red	Internal error	Module has caused an unrecoverable internal error.

Link/Activity

LED status	Description	Comments
Off	Module has no connection	<ul style="list-style-type: none"> - No connection - No communication
Constant green	Module has a connection	<ul style="list-style-type: none"> - There is an Ethernet connection. - No communication
Flickering green	Activity	<ul style="list-style-type: none"> - There is an Ethernet connection. - Communication is available.

PR 1721/77

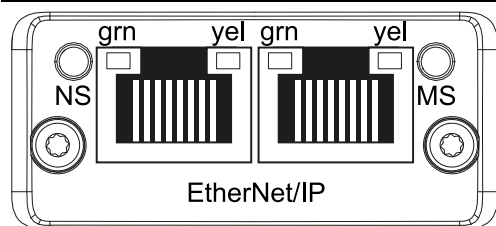

Identification	Description
NS	Network status LED
MS	Module status LED
grn	Green: flashes when there is data traffic (activity)
yel	Yellow: lights up when there is an existing connection (link)

Network status (NS)

LED status	Description	Comments
Off	Module is offline	<ul style="list-style-type: none"> - No power - No IP address
Constant green	Module is online	One or more connections exist (CIP class 1 or 3)

LED status	Description	Comments
Flashing green	Module is online	No connection
Constant red	Critical connection error	- Duplicate IP address - Severe error
Flashing red		One or more connections has exceeded the connection time (CIP class 1 or 3).

Module status (MS)

LED status	Description	Comments
Off	Module is offline	No power
Constant green	Normal operation	Controlled by a scanner (run state).
Flashing green	Idle	- No configuration - Scanner is in the idle state.
Constant red	Exception error	- Module has the status "EXCEPTION" - Severe error - etc.
Flashing red	Error that can be corrected	The module is configured but the saved parameters are different from those being used.

5 Maintenance/repairs/soldering work/cleaning

5.1 Maintenance

Maintenance work may only be carried out by a trained technician with expert knowledge of the hazards involved and the required precautions.

5.2 Repairs

Repairs are subject to inspection and must be carried out at Minebea Intec.

In case of defect or malfunction, please contact your local Minebea Intec dealer or service center for repair.

When returning the device for repair, please include a precise and complete description of the problem.

5.2.1 Battery for date/time

The lithium battery for backing up the calendar/time chip is located on the main board. The battery is activated before the device leaves the factory.

Note:

After initial start-up, the date and time must be checked and set if necessary .

5.2.1.1 Changing the battery for date/time

The device is equipped with a lithium battery for backing up the time/calendar chip. If the voltage drops below the specified minimum, or in case of defect, the battery must be replaced by Minebea Intec customer service or by an equivalent trained technician.

For disposal information, see Chapter [6](#).

For battery lifespan, see Chapter [7.3.1](#).

If the battery needs to be changed, this is shown on the display.

5.2.2 Rechargeable battery for power supply

This device contains an NiMH rechargeable battery.

In the event of a power failure, the processor is supplied for approx. 1 min. in order to save the current state and shut down properly.

5.2.2.1 Changing the rechargeable battery for power supply

If the voltage drops below the specified minimum, or in case of defect, the battery must be replaced by Minebea Intec customer service or by an equivalent trained technician.

For disposal information, see Chapter [6](#).

5.2.3 Exchanging the plug-in cards

5.2.3.1 Safety instructions

⚠ WARNING

Working on the device while it is switched on may have life-threatening consequences.

Before a plug-in card is inserted/removed, it is essential that

- ▶ the device is shut down properly (menu [Operating]- [System maintenance]- [Shutdown & Power off]).
- ▶ the device is disconnected from any power sources.
- ▶ all LEDs have gone out.

5.2.3.2 Optional and fieldbus cards



Note:

If an optional card is to be replaced with a fieldbus card, the mounting plate (1) must be rotated.

- ▶ Plug all the connectors back in and switch the device back on.
 - ▷ Once the plug-in cards have been replaced, the device will detect them automatically.

Note:

The installed plug-in cards can be displayed in the menu [Operating] - [System information] - [Show HW options].

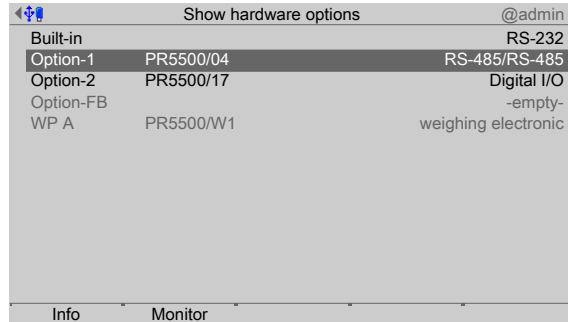

Showing hardware options			Description
Internal		RS-232	Interfaces (fixed installation)
Option 1	PR 5500/04	RS-485/RS-485	Slots for optional cards 1 and 2
Option 2	PR 5500/19	Digital I/O	
FB option		-empty-	Slot for fieldbus cards, in this case: [-empty-] because a fieldbus card has not been installed.
WP A	PR 5500/W1	Weighing electronics	Slot for WP A, in this case: Internal weighing electronics

5.2.3.3 Terminal coding

The relevant plug connections will be coded when delivered according to the combinations specified when placing the order. The plug connections will only need to be coded if plug-in cards are supplied subsequently.

The coding position for each of the plug-in cards is outlined in Chapter 4.5.

Procedure

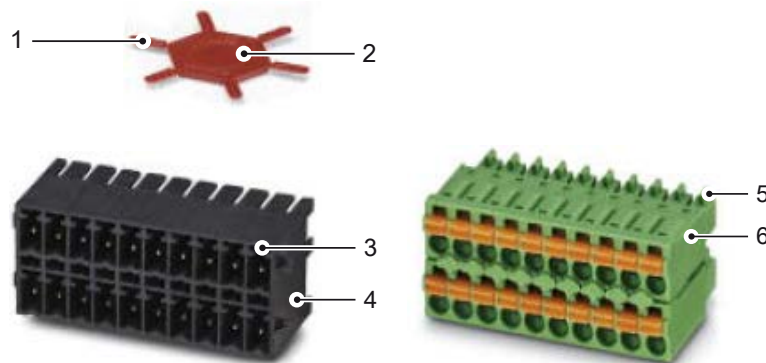

1. Remove the terminal (6) from the terminal strip (4).
2. Remove the coding pin (1) from the coding profile (2).
3. Insert the coding pin (1) into the corresponding slot (3) in the terminal strip (4).

4. Remove (nip off) the corresponding coding nib (5) from the terminal (6).
5. Re-insert the terminal (6) into the terminal strip (4).

5.2.4 Replacing the SD card

Note:

Only Minebea Intec supplied SD cards may be used. No warranty can be assumed for third-party cards.

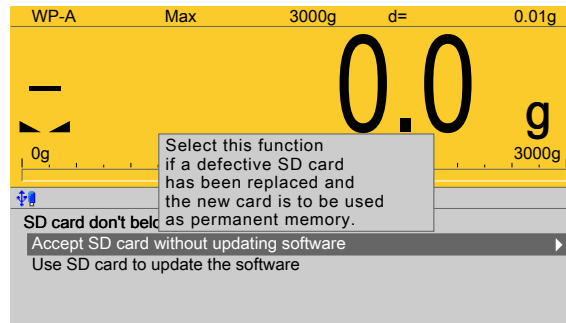

1. To back up the data on the device onto a USB stick, see the [System maintenance] - [Backup] - [USB stick] in the PR 5500 operating instructions.
2. Remove the faulty SD card.
3. Insert the new SD card.
4. Only if the new card has already been used in another device: Press the STOP and EXIT keys at the same time to trigger a cold start.
5. Only if the new card has already been used in another device: Select [Accept SD card without updating the software] from the menu and confirm.
6. To load data from a USB stick back into the device, see PR 5500 [System maintenance] - [Restore] - [USB stick] in the operating instructions.

5.2.5 Replacing the device

When replacing a faulty device, the software on the device can be completely imported into the new device by plugging the SD card of the old device into the new one.

The settings and database can be restored from the SD card (backup); see [System maintenance] - [Restore] - [SD card] in the PR 5500 operating instructions.

If the licenses (including board number) are also transferred to the new device, the SIL chip of the old device must also be connected to the new device.

⚠ CAUTION

The SD card is a fixed component of the device.

- ▶ The SD card should only be removed together with the SIL chip during servicing.
- ▶ The SD card may not be used for data transfers.

Procedure

⚠ WARNING

Working on the device while it is switched on may have life-threatening consequences.

Before a plug-in card is inserted/removed, it is essential that

- ▶ the device is shut down properly (menu [Operating]- [System maintenance]- [Shutdown & Power off]).
- ▶ the device is disconnected from any power sources.
- ▶ all LEDs have gone out.

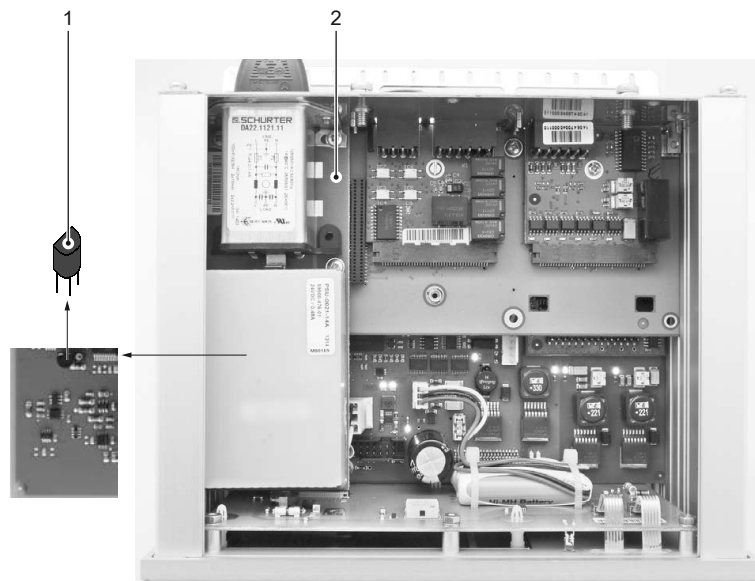

1. Dismantle the complete mounting plate (2).
2. Remove the SIL chip (1) and the SD card from the faulty device.
3. Insert the SIL chip and SD card into the replacement device.
4. Switch on the device.
5. Press the STOP and EXIT keys at the same time to trigger a cold start (for presets see [System setup] - [Operating parameters] in the PR 5500 operating instructions).
 - ▷ A selection window opens.

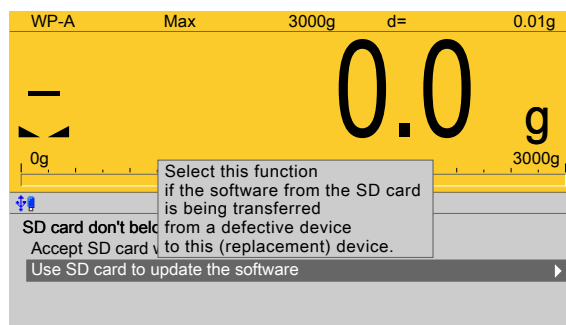

6. Select [Use SD card to update the software] from the menu and confirm.
 - ▷ The device installs the BIOS, firmware, and application from the SD card.

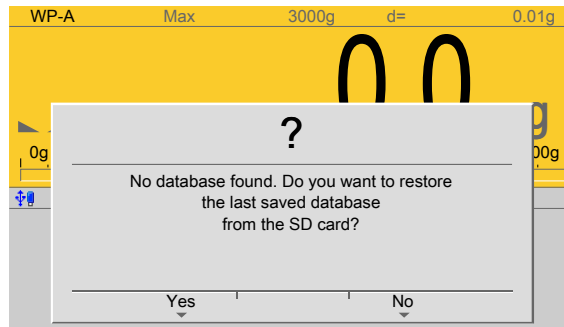

A selection window opens if no database file is found in the directory.

7. Press the [Yes] soft key to restore the database from the faulty device on the replacement device.
8. For further settings, refer to [System maintenance] - [Restore] - [SD card] in the PR 5500 operating instructions.

5.3 Soldering work

Soldering work on the device is neither required nor permitted.

5.4 Cleaning

NOTICE

Property damage caused by unsuitable cleaning utensils/agents.

Damage to the device.

- ▶ Prevent moisture from penetrating the interior.
- ▶ Do not use aggressive cleaning agents (solvents or similar agents).
- ▶ For use in the food industry, use a cleaning agent suitable for that particular working environment.
- ▶ Use soft sponges, brushes and cloths.
- ▶ Spraying with water or blasting with compressed air is not permitted.

1. Unplug device from mains supply, disconnect any data cables.
2. Clean the device with a cloth lightly moistened with a soap solution.
3. Wipe down the device with a soft, dry cloth after cleaning.

6 Disposal

Our products and their packaging should not be disposed of in municipal waste (e.g. garbage can for recyclable packaging, garbage can for paper packaging, etc.). They can either be recycled by the customer themselves, providing this complies with requirements set out by electrical or electronic waste or packaging waste laws, or sent back to Minebea Intec at a charge.

This option of returning the product is intended to provide proper recycling or reuse in a manner that is collected separately from municipal waste.

Before disposing of or scrapping the old products, any single-use or rechargeable batteries should be removed and taken to a suitable collection point. The type of battery used is specified in the technical data.

Please see our General Terms and Conditions for further information.

Service addresses for repair acceptance and collection points can be found on the product information enclosed with the product as well as on our website (www.minebea-intec.com).

Should you have any further questions, please contact your local service representative or our service center.

Minebea Intec GmbH

Repair center

Meiendorfer Strasse 205 A

22145 Hamburg, Germany

Phone: +49.40.67960.333

service.HH@minebea-intec.com

We reserve the right not to accept products that are contaminated with hazardous substances (ABC contamination).

7 Technical data

7.1 Note on using "free software"

The firmware on the PR 5500 device contains "free software" that is licensed under the

- GNU General Public License (GPL) Version 2, June 1991, and
- GNU Lesser General Public License (LGPL) Version 2.1, February 1999.

This device also contains "free software" from MIT and BSD.

This "free software" developed by third parties is copyrighted and is provided free of charge. The license terms and conditions of Free Software Foundation, Inc. in English are included in the delivery of the device. The source text for the terms and conditions can be found on the CD-ROM included.

7.2 Decoding the serial number

30 252 00015		
30	252	00015
Location no.:	Code for the year/month:	Current number
30 = Hamburg	252* = April 2010	

* Is increment according to the year group table of Minebea Intec.

7.3 General data

The following characteristics are valid after a warm-up time of at least 60 minutes (reference temperature 23 °C).

7.3.1 Backup for date/time

The lithium battery for backing up the date/time chip is activated before the instrument leaves the factory.

Lifespan	Device continuously connected to mains voltage	up to 10 years
	Device not connected to mains voltage for some time (e.g. in storage)	up to 7 years

7.3.2 Rechargeable battery for power supply

The NiMH rechargeable battery continues to supply the processor for approx. 1 minute after a power failure has occurred in order to save the current status of the device. The temperature of the rechargeable battery is monitored and can be displayed.

7.3.3 Display

Type	Size	Display
TFT color display	4.3"	480 x 272 pixels

7.3.4 Supply voltage connection 230 V AC

Supply voltage	$U_{AC} = 100$ to 240 V	+10 %/-15 %, 50/60 Hz
Max. power consumption	14 W/32 VA	
Primary fuse	2 x 1 AT; 250 V, 5 x 20 mm; Littlefuse series 218, order no. 0218.001.P	

7.3.5 Supply voltage connection 24 V DC

Supply voltage	$U_{DC} = 24$ V	±10%
Max. power consumption	14 W	
Primary fuse	1 x 2 AT; 250 V; 5 x 20 mm; e.g.: Schurter: SPT5 x 20, order number: 0001.2507	

7.4 Effect of ambient conditions

7.4.1 Ambient conditions

Temperature range	
Ambient temperature for operation	-10...+50 °C
Ambient temperature "verifiable"	-10...+40 °C
Power-on temperature	>0°C
Limits for storage/transport	-20...+70 °C
Moisture	<95%, non-condensing (acc. to IEC 60068-2)
Protection class	Front IP65, back IP20
Altitude	<2000 m

7.4.2 Electromagnetic Compatibility (EMC)

All data in compliance with NAMUR NE 21, EN 45501 and EN 61326.

Housing	High frequency electromagnetic fields (80...3000 MHz)	EN 61000-4-3	10 V/m
	Electrostatic discharge (ESD)	EN 61000-4-2	6/8 kV
Signal and control lines	Fast transients (burst)	EN 61000-4-4	1 kV
	Peak voltages (surge) 1.2/50 μs	EN 61000-4-5	1/2 kV
	Conducted disturbances by high frequency coupling (0.15...80 MHz)	EN 61000-4-6	10 V

Mains inputs	Fast transient disturbances (Burst)	EN 61000-4-4	2 kV
	Peak voltages (surge) 1.2/50 μ s	EN 61000-4-5	1/2 V
	Conducted disturbances by high frequency coupling (0.15...80 MHz)	EN 61000-4-6	10 V
	Voltage dips	EN 61000-4-11	0/40/70% 20/200/500ms
	Mains failure link	EN 61000-4-11	20 ms

7.4.3 RF interference suppression

Interference emission



EN 55011, Group 1, Limit class A, for industrial sectors

7.5 Mechanics

7.5.1 Design

Control cabinet housing made of stainless steel and aluminum, protection class IP65, rear IP20.

7.5.2 Dimensions

Width	186/192/199 mm
Height	90/96/103 mm
Depth	approx. 203 mm (incl. screen clamping rail)

7.5.3 Weights

Net weight	2.2 kg
Shipping weight	3.1 kg

7.6 Use in legal metrology

7.6.1 Documentation relating to calibration on the CD included

The documents and manuals listed in the appendix (see Chapter [8.1](#)) can be found on the PR 5500 CD.

7.6.2 Further information

For information about the significance of the CAL switch to be sealed, see Chapter [4.4.1](#) and [Commissioning] - [Overwrite protection] - [CAL switch] in the PR 5500 operating manual.

Ensure that the parameter settings (see [System setup] - [Weighing points] - [Internal weighing point] - [Parameters] in the PR 5500 operating manual) selected comply with the legal requirements as well as the provisions of EC type approval certification.

The party installing the scale is responsible for selecting legally permissible settings. These settings need to be checked.

8 Appendix

8.1 Certificates

Ser. no.	Description	Document no.
1	EU-Declaration of Conformity	MEU17035
2	Declaration of Conformity	MDC17004
3	Parts Certificate PTB	DE.18-PC-PTB002
4	Certificate of Conformance NTEP	18-029
5	EU-type examination certificate NMI	T11379

The documents listed in the table can be found on the PR 5500 CD.

Published by
Minebea Intec GmbH | Meiendorfer Strasse 205 A | 22145 Hamburg, Germany
Phone: +49.40.67960.303 | Email: info@minebea-intec.com
www.minebea-intec.com

